

LV72-1

ILLUS	PART NUMBER	DESCRIPTION
1	706-223D-05	SIGN FRAME ASSY
2	409-058B	SIGN GRID 74 1/4 X 8.5
3	503-229B-02	LAMP 25 W F25 T 8
4	503-271B	LAMP RECEPTACLE (Holder)
5	503-273D	BALLAST, WH4-120V
6	501-170D	EVAP MOTOR .55 AMPS 120-60 U
7	405-062A	EVAP BLADE 6"WHITE(4 PET PLAS)
8	42A37-011B	BRACKET - MOTOR PAINTED
9	403-698B	GUARD - FAN
10	42B30S265D-01	HOUSING-EVAP FAN ASSEMBLY
10B	42A35S241D-01AB	EVAP FAN HOUSING ONLY, WHITE
11	43B32S308D-01	EVAP DRAIN PAN ASSEMBLY
12	502-289B	CONTROL-TEMP W/ KNOB
13	502-068A	SWITCH - DUAL CIRCUIT
14	503-230B-02	LAMP 32 W F32 T 8
15	713-062C-03	SHIELD - LAMP F32 46.438
16	710-037D-01	DOOR HANDLE - HINGE DOOR LV
17	40B48S161D-07AA	DOOR ASSY - RH & CTR, BLACK LV72
18	40B48S161D-08AA	DOOR ASSY, LH , BLACK LV72
19	712-031D-04	GASKET, DOOR LV72
20	403-096A	PILASTER, 54 INCH, REAR
21	403-092A	PILASTER, 48 INCH, FRONT
22	403-168A	SUPPORT - SHELF ZG SHORT TAB
23	403-874D-01	SHELF - WIRE, 22.75X21.5 LV66/72
24	401-263A-02	HINGE, SPRING CARTRIDGE, RH, CTR, LH - BLACK
25A	401-840D-02	BRACKET -HINGE BOT RH & CTR, BLACK
25B	401-842D-02	BRACKET -HINGE BOT LH BLACK
26A	401-841D-01	BRACKET -HINGE TOP RH & CTR, BLACK
26B	401-843D-01	BRACKET -HINGE TOP LH BLACK
	603-400A	SCREW HHMS 1/4-20 X 3/4, BLACK (for hinge brkt)
27	49B36S501D-01	REFRIGERATION SYSTEM ASSEMBLY
28	49B34S412D-01	CONDENSING UNIT ASSEMBLY
29	49B31S340D-01	EVAP COIL ASSY
30	305-442D	EVAP COIL 4 X 7 X 28
31	49B30S453D	SUCTION & CAPILLARY TUBE ASSY.
32	203-125A	CAPILLARY TUBE (0.062 ID X 60 ")
33	305-159C	CONDENSER COIL , 13-1/4X10-7/8X4
34	302-626B	COMPRESSOR, 1/2HP 115-60 TEC AKA4476YXA
35	302-628A	START CAP 378/455 MFD @125 VAC
36	302-290A	RELAY (GE)82481-1
36	302-439A	OVERLOAD T18300MRTJ79
37	501-158B-01	COND MOTOR, 16W 115V GE
38	405-066B	COND BLADE 10" (5 PET ALUM)
39	303-145A	DRYER - FIELD REPLACEMENT - SOLID CORE
40	43B32S208C	CONDENSATE PAN ASSEMBLY
41	703-444A	WICK 2-1/2X6-3/4X1/8
42	706-030D	CONDENSATE DRAIN PAN (PAN ONLY)
43A	44A11-742D-05AA	GRILLE, BOTTOM, BLACK
43B	44A11-742D-05AB	GRILLE, BOTTOM, WHITE
	401-670A	LEVELER LEG, 1/2-13 W/HEX HEAD

LV72

hinge brkt, top, LH 26B

INTERIOR FAN HSG

- evap motor 6
- evap blade 7
- evap mtr mount 8
- evap fan guard 9
- evap housing assy 10
- evap drain pan assy 11
- temp control 12
- switch, dual circuit 13

INT. LIGHT ASSY (behind mullions)

- lamp, interior 14
- receptacle, lamp 4
- shield, lamp, interior 15

handle, door 16

- hinge cartridge 24
- hinge brkt, bottom, LH 25B

- 1 frame, sign
- 2 sign
- 3 lamp, sign and interior
- 4 receptacle, lamp (sign and interior)
- 5 ballast

26A hinge bracket, top, RH & CTR

17 door, assy, RH & CTR

18 door, assy, LH

19 gasket, door

20 pilaster, 54 inch, shelf support

21 pilaster, 48 inch, shelf support

22 clip, shelf support

23 shelf

24 hinge cartridge, RH, LH, & CTR

25A hinge bracket, bottom, RH & CTR

43A Grille, BLACK

43B Grille, WHITE

REFRIGERATION SYSTEM ILLUSTRATION

REFRIGERATION ASSEMBLY (COMPLETE) 27

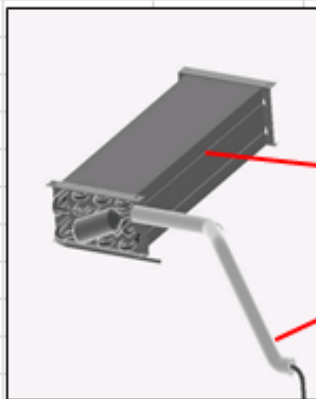

EVAPORATOR COIL ASSEMBLY 29

EVAPORATOR COIL 30

SUCTION LINE & CAP TUBE ASSY. 31 & 32

FAN BLADE 38

CONDENSER FAN MOTOR 37

DRIER 39

33 CONDENSER COIL

41 WICKING

42 CONDENSATE PAN

40 CONDENSATE PAN ASSEMBLY

COMPRESSOR 34

CAPACITOR, START 35

RELAY & OVERLOAD 36

CONDENSING UNIT ASSY 28

