



# Beverage Air

## **IMPORTANT INFORMATION**

### FOR LV SERIES

This cooler has passed the  
QUALITY CONTROL INSPECTION  
And meets the high standards at Beverage-Air  
This inspection includes complete refrigeration  
System, cabinet construction & finish.

IMPORTANT  
PLEASE RETAIN FOR YOUR RECORDS

**SALES OFFICE: 3779 CHAMPION BLVD., WINSTON - SALEM, S.C. 27105**  
**PHONE: (336) 245-6400 TOLL FREE 1-800-845-9800**  
**TECHNICAL SERVICE: 1-800-684-1199, PARTS ORDER FAX: 1-800-262-**  
**9381CORPORATE OFFICE: WINSTON-SALEM, NC**  
**MANUFACTURING FACILITY: BROOKVILLE, PA.**



## INSTALLATION AND OPERATING INSTRUCTIONS

Models: MT/RI/FC

### 1. Installation

a. Receiving Inspection:

Upon receipt, check all packages and accessories or optional components including legs, casters, and shelves.

b. Legs & Casters: (optional) (See Fig. 1)

Legs screw directly into the base. Caster are plate-mounted. To install casters, tip or raise the cabinet one side at a time and remove the four hex head screws in each corner of the bottom. Use these same screws to attach the mounting plate. Screw-on type legs simply screw into the adapter nut provided in each corner of the bottom. Important: Verify local sanitation codes if unit is to be used for packaged foods.

c. Leveling: (See Fig. 2)

To provide adequate condensate drainage and proper door alignment and operation. It is necessary that the cabinet be level. Level cabinet from front to rear and from side to side with leveling bolts, or leg inserts. This should be done after cabinet has been set in its final operating position. The leveling bolts are the same bolts used to attach the wood base to the cabinet. **BE SURE DRAIN HOSE IS ATTACHED TO BRACKET NEXT TO EXTERIOR CONDENSATE PAN LOCATED BEHIND BOTTOM GRILLE. THE HOSE COULD BE DISLODGED IN TRANSIT.**

d. Door Handles: (See Fig 3.) Hinged Door Models

Door handles with mounting screws are packed inside each cooler.

To mount handle, lift door gasket behind two holes in front and insert screws through the holes. Attach handle, with offset away from cabinet corner, and tighten screws.

e. Shelves:

Shipped inside each cabinet are shelves packed in plastic and a bag of shelf supports. Shelf spacing is adjustable to suit requirements. See Instruction Sheet ILA-0904 for installing.

f. Door Removal and Adjustment:

(1) Slide Doors - Each door has its own Closing Spring located at the top and is positioned for Proper Tension. However if adjustment is required remove doors as follows:

- a. Locate Door Rollers under slot (A) show in fig. 4, and lift door off track while tilting bottom of door out.

Adjust spring by moving hook to next hole or by shortening.

If door gaskets do not seal properly follow step 1 and 2.

Step 1: Check to see if cabinet base is level.

Step 2: Adjust the Location of door Rollers in the Roller Brackets.

(2) Swing Doors - Spring tension in the bottom hinges is Factory Adjusted for adequate "Swing Back" of doors, and does not require field adjustment. For replacement parts and instructions see enclosed instruction sheet ILA-0859.

g. Locating Cooler:

Provide at least three inches of space between cabinet and any adjacent wall or fixture, at left end and rear of cabinet.



## 2. Operation

- a. **Electrical Supply and Connections:**  
Plug all standard models into 115 volts A.C. 60 cycle outlet. Low line voltage is often the cause of service complaints. Check to see that the line voltage is 110 volts or more with the unit running. Other motors or heavy appliances should not be used on the same circuit with the cooler. When working on the inside of the cooler disconnect from electrical circuit for safety reasons. **CAUTION:** If an extension cord is necessary, use only a three wire grounding type of wire size 16 AWG or larger; do not exceed 20 ft. in length. The use of ungrounded cords or overloaded circuits voids compressor warranty.
- b. **Initial Start-Up:**  
Turn Power on and check to verify that the condenser fan is running. The fan and light switches are located on the blower housing front inside the cabinet. The fan switch should be set to the "OFF" position for reduced condenser fouling. The fan Switch in "ON" position permits the Condenser Fan to run continuously for maximum condensate evaporation in high humidity locations. Note: For units with Bare Tube Condensers, the ambient temperature must be above 60°F during initial startup to ensure that the unit begins to cool properly.
- c. **Temperature Control:**  
Factory setting of temperature control is at No. 5 position (normal) which will maintain the product at about 36°F.\* For colder temperatures, turn knob clockwise one number at a time. Excessive tampering with temperature control could lead to service difficulties. For operation above 3000 ft. altitude, have thermostat adjusted by a qualified serviceman.
- d. **Condensate Disposal:**  
The evaporator blower housing serves as a pan to collect and direct the condensate to the evaporator pan located behind the front grille. Air flow over the pan hastens condensate evaporation so that external drain plumbing is not required.

## 3. Maintenance - **Caution: Disconnect electrical service before accessing mechanical enclosures having moving and/or electrical components.**

- a. **Cleaning Cabinet Exterior:**  
Cabinets should be cleaned with a solution of mild soap and water. Do not use caustic soap or abrasive cleaners, since these might damage the cabinet finish. If stainless steel surface becomes discolored, scrub by rubbing only in the direction of the finish grain. Do not use steel wool.
- b. **Cleaning Interior Surfaces:**  
The inside of the cabinet is coated with baked-on vinyl (except stainless steel cooler). To clean, use mild soapy water and cloth or sponge.
- c. **Condenser:**  
For efficient operation, it is recommended that the condenser coil and fans be cleaned every 3 to 6 months. Remove front grille for access. Vacuum clean front surface of coil thoroughly or direct forced air through condenser fins. Failure to clean condenser can cause compressor malfunction and will void warranty.
- d. **Evaporator Fan:**  
Evaporator pan should be cleaned periodically to prevent odors and maintain evaporating efficiency. The pan contains wicks to assist evaporation and should be replaced periodically.
- e. **Evaporator Housing:**  
If internal parts (e.g. fans, control) are to be serviced, lower housing as shown in (Fig 5). Make certain to remove drain tube before lowering housing.

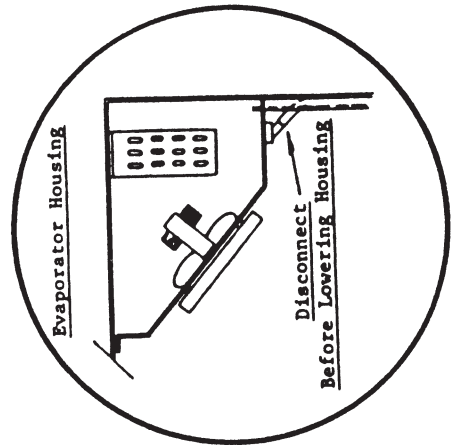
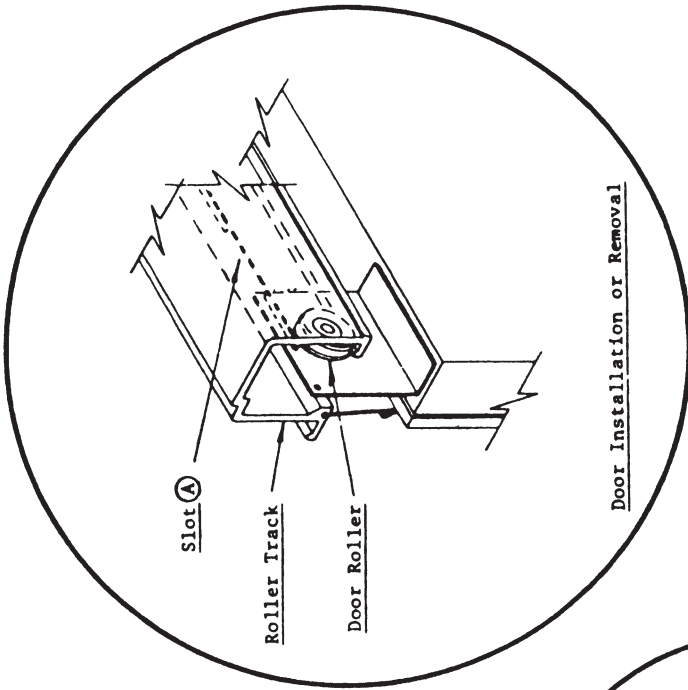
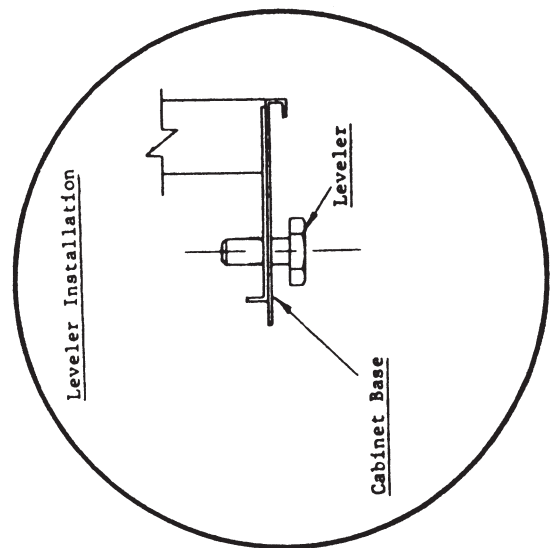
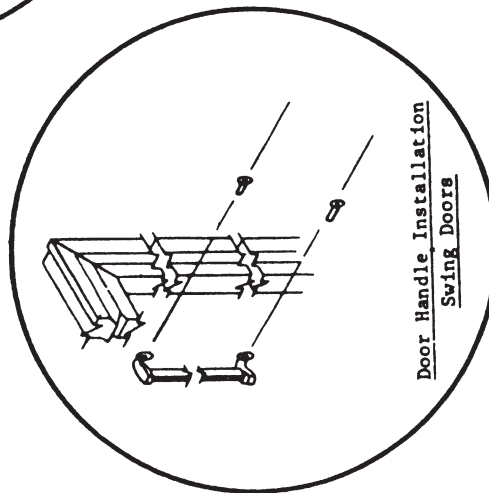
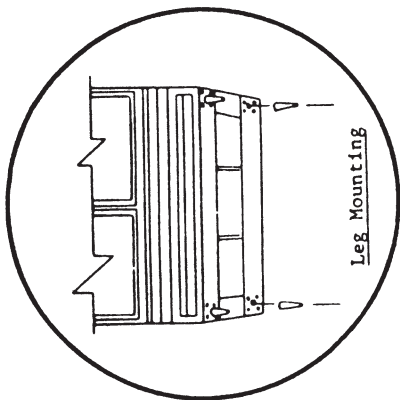

# HINGE TO DOOR AND DOOR TO CABINET

## ASSEMBLY INSTRUCTIONS

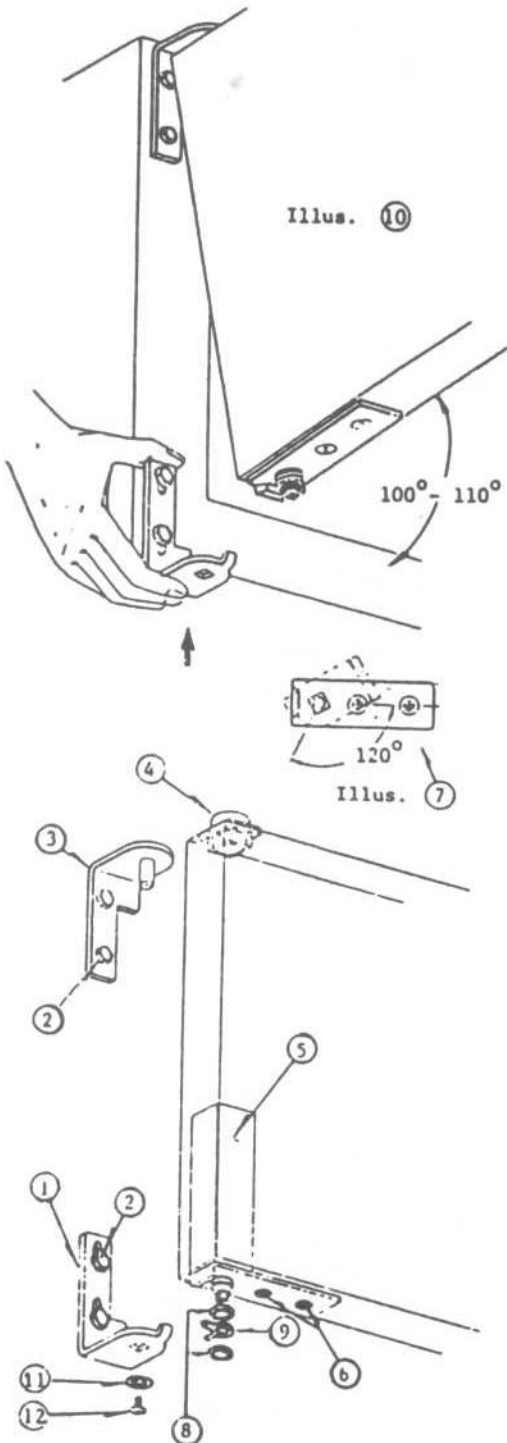

A. Place lower bracket (1) in position on cabinet and loosely fasten with 1/4" hex head bolts, (2). Brackets must be allowed to move up with hand pressure.

B. Place upper bracket (3) in position on cabinet and tightly fasten with 1/4" hex head bolts, (2).

C. Push nylon pivot bushing (4) into the square opening at the door top.

D. Insert cartridge assembly (5) into square opening on bottom of door and secure with #10 countersunk screws, (6).

E. Using the square opening of an extra bottom bracket or a wrench, rotate the square head of the cartridge shaft approximately 120° in closing direction of door. Hinge is now preloaded and ready to be secured to door bracket (See Illus. 7.)

F. Place nylon washer (8), stop spring (9) and second washer (8) over cartridge shaft. Tape to door to secure during mounting of door. Spring, (9) should have tabs facing front of door.

G. Hold door in a 100° position from cabinet face as shown in Illus. (10). Proceed to place upper corner over the protruding bracket pin. Insert square shaft of cartridge into square opening of bottom bracket.

H. Proceed to insert bottom retaining screw, (11). Fasten securely . . . Door can now be closed and will function properly.

# SHELF SUPPORT LOCATION ILLUSTRATION

ILB-1621  
ALL MTS

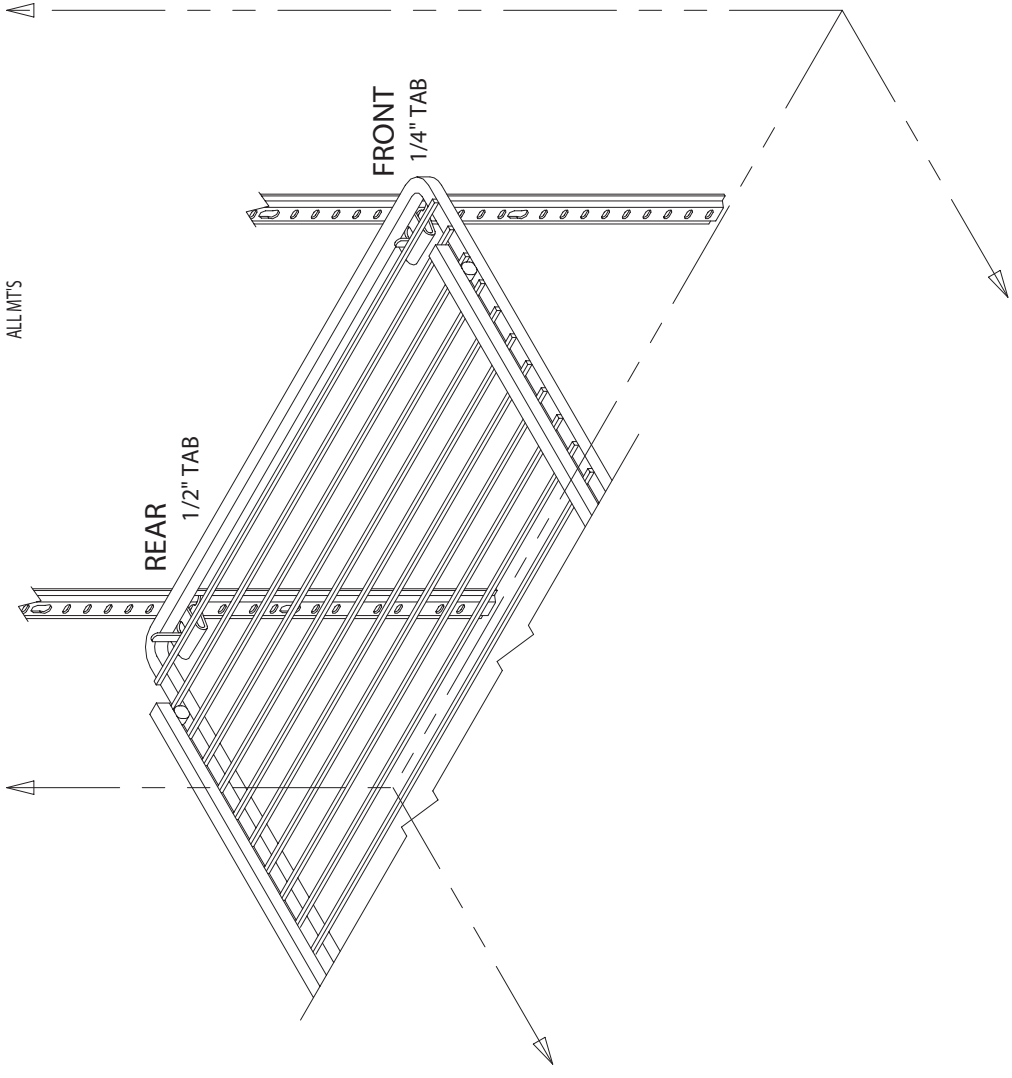
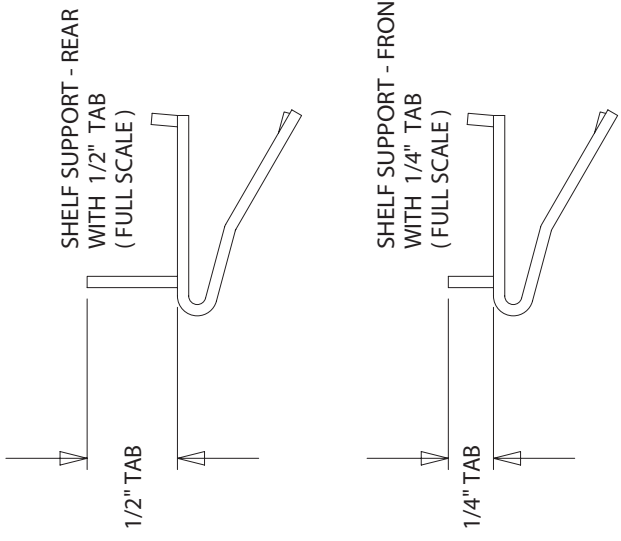

-- NOTES & INSTRUCTIONS --

1. PLACE SHELF SUPPORTS WITH 1/4" TABS INTO PILASTER AT DESIRED POSITION.  
( NOTE THAT SUPPORTS WITH 1/4" TABS ARE LOCATED AT FRONT ONLY )
2. PLACE SHELF SUPPORTS WITH 1/2" TABS INTO PILASTER AT DESIRED POSITION.  
( NOTE THAT SUPPORTS WITH 1/2" TABS ARE LOCATED AT BACK ONLY )

## Bi-pin Fluorescent Lamp Installation / Verification

Prior to applying power to the unit, verify that all lamps are properly installed and fully engaged in the lamp holders.

Proper lamp engagement is achieved by rotating the lamp 90° from its insertion position until it “snaps” or “clicks” into place.

Visual verification can be made on units without safety shields by using the identification mark on the end of the bulb. Properly installed bulbs will have the mark centered between the “halves” of the lamp holder.

On units with shields, the identification mark cannot be seen. Physically verify that the lamp has been rotated and locked into place.

See pictures below.

**Caution: Improperly installed lamps may cause damage to the lighting circuit.** Beverage-Air shall have no liability whatsoever for equipment or component failures or other damages or losses which arise as a result of improper installation.

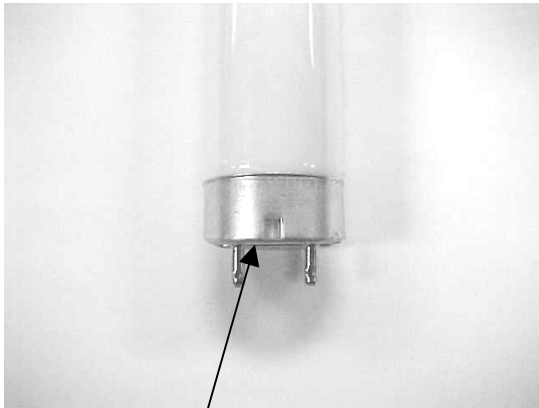

Bi-pin lamp end  
Identification mark



Properly installed lamp without shield. Verify  
identification mark is positioned as shown.

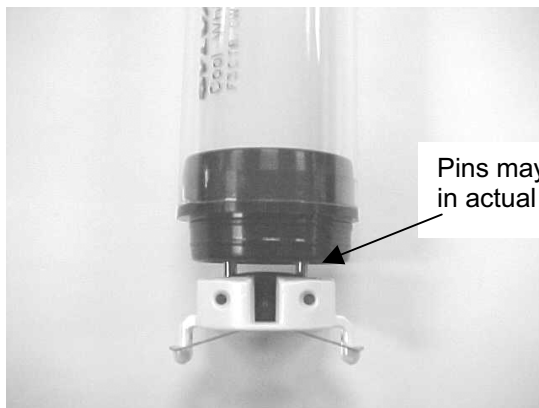

Properly installed lamp with shield.  
Requires physical verification that lamp has  
been rotated and locked into place.

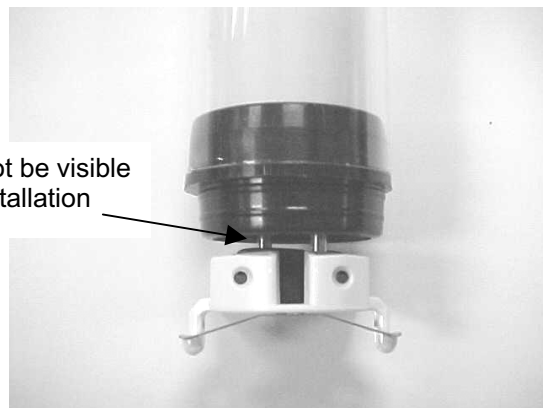

Improperly installed lamp with shield.  
Note that pins have not achieved full 90° rotation.

# SHELF CLIP INSTALLATION

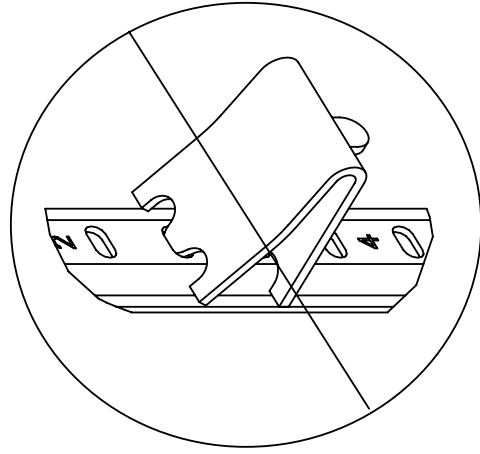

IMPROPERLY INSTALLED  
CLIP ( UPSIDE DOWN )

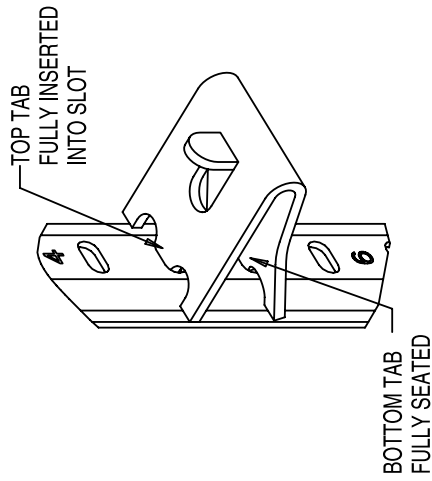

PROPERLY INSTALLED  
CLIP

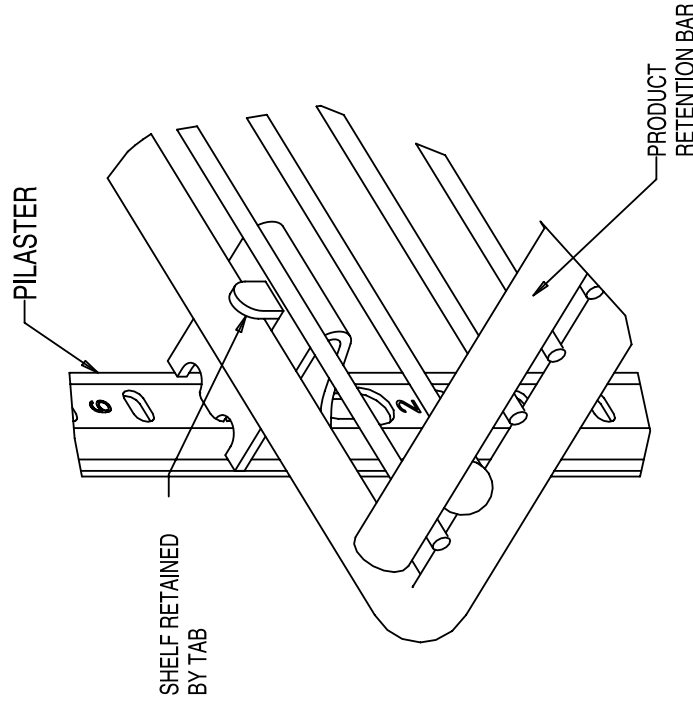
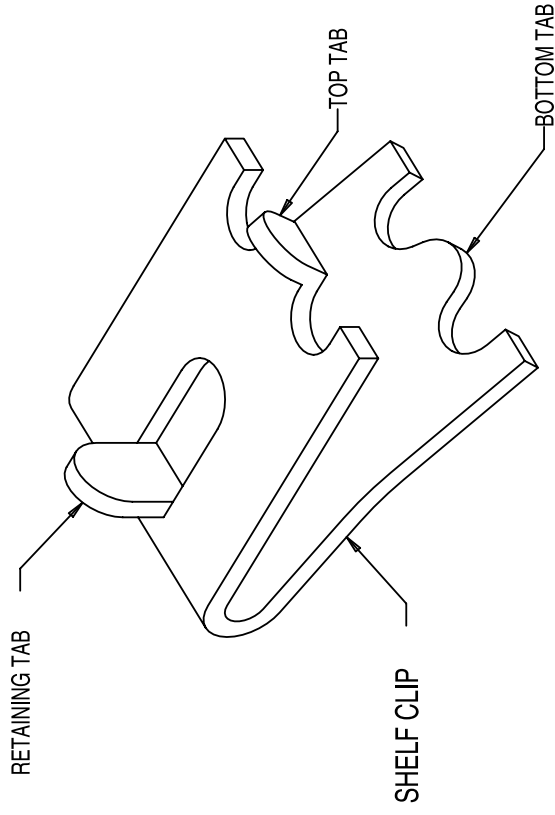

## INSTALLATION INSTRUCTIONS

- 1) DETERMINE PROPER LOCATION FOR SHELF CLIPS. THE REFERENCE NUMBERS ON THE PILASTER CAN SERVE AS A GUIDE TO ENSURE ALL CLIPS ARE PROPERLY LOCATED.
- 2) INSERT TOP TAB OF THE SHELF CLIP INTO THE DESIRED HOLE OF THE PILASTER. THE RETAINING TAB SHOULD BE FACING UPWARDS AS SHOWN.
- 3) ROTATE THE CLIP DOWNWARDS AND INSERT THE BOTTOM TAB INTO THE APPROPRIATE HOLE ON THE PILASTER. THE CLIP MAY NEED TO BE SQUEEZED SLIGHTLY DURING INSTALLATION.
- 4) INSTALL ALL REMAINING CLIPS AS DESCRIBED ABOVE.
- 5) INSTALL SHELVES ONTO CLIPS WITH THE PRODUCT RETENTION BAR FACING UPWARD. BE CAREFUL NOT TO DISLodge CLIPS DURING SHELF INSTALLATION.
- 6) SHELVES MUST BE PLACED SUCH THAT THE RETAINING TAB ON THE SHELF CLIP CAPTURES THE SHELF AS SHOWN.
- 7) PRIOR TO LOADING THE SHELF, ENSURE THAT THE SHELF IS RESTING ON EACH OF 4 CLIPS AND THE CLIPS ARE INSTALLED AS SHOWN.

## WARNING

- IMPROPER SHELF CLIP INSTALLATION MAY CAUSE SHELF AND/OR PRODUCT TO FALL RESULTING IN DAMAGE TO THE UNIT AND BODILY INJURY.
- DO NOT OVERLOAD THE SHELVES. THE UNIT IS DESIGNED TO UTILIZE ALL SHELVES THAT ARE SUPPLIED IN AN EQUALLY SPACED MANNER. IF LESS SHELVES OR A DIFFERENT CONFIGURATION IS DESIRED, CONTACT THE MANUFACTURER TO ENSURE SHELF OVERLOADING WILL NOT OCCUR.



# METHODS FOR CLEANING STAINLESS STEEL

	CLEANING AGENT*	METHOD OF APPLICATION**	EFFECT ON FINISH
Routine Cleaning	Soap, ammonia or detergent and water.	Sponge with cloth, then rinse with clear water and wipe dry.	Satisfactory for use on all finishes.
Stubborn spots and stains, baked-on splatter, and other light discoloration's.	Revere Ware cleaner, Twinkle, or Cameo stainless steel cleaner.	Apply with damp sponge or cloth. Rub with damp cloth.	Satisfactory for use on all finishes if rubbing is light. Use in direction of polish lines.
	Goddard's Stainless Steel Care, Revere Ware Stainless Steel Cleaner, Soft-Scrub.	Apply with damp sponge or cloth.	Use in direction of polish lines. May scratch or dull highly polished finishes.
	Household cleansers, such as Old Dutch, Zud, Bon Ami, Ajax, Comet	Rub with a damp cloth. May contain chlorine bleaches. Rinse thoroughly after use. Rub with a damp cloth.	
Heat tint or heavy discoloration	Revere Ware Stainless Steel Cleaner, Goddard's Stainless Steel Care.	Apply with damp sponge or cloth.	
Burnt-on foods and grease, fatty acids milkstone (where swabbing or rubbing is not practical)	Easy-Off Oven Cleaner	Apply generous coating. Allow to stand for 10 to 15 minutes. Rinse. Repeated application may be necessary.	Excellent removal. Satisfactory for use on all finishes.
Hard water spots and scale.	Vinegar	Swab or wipe with cloth. Rinse with water and dry.	Satisfactory for use on all finishes.

\*Use of brand names is intended only to indicate a type of cleaner. This does not constitute an endorsement. Nor does the omission of any brand name cleaner imply its inadequacy. Many products named are regional in distribution and can be found in local supermarkets, department and hardware stores.

\*\*It is emphasized that all products should be used in strict accordance with instructions on package.

1. Use the mildest cleaning procedure that will do the job efficiently and effectively.
2. Always rub in the direction of polish lines for maximum effectiveness and to avoid marring the surface.
3. Use only a soft cloth, sponge, fibrous brushes, plastic or stainless steel pads for cleaning and scouring.
4. Rinse thoroughly with fresh water after every cleaning operation.
5. Always wipe dry to avoid water marks.
6. **Never use common steel wool pads, these will cause rust!**

**BEVERAGE-AIR**

P.O. BOX 5932, Spartanburg, SC 29304-5932 Phone 800-845-9800 Fax 864-582-5083

MADE IN USA

ILA-1265 Rev.B

# SERVICE AND ANALYSIS CHART

# REFRIGERATION SYSTEM

MALFUNCTION	POSSIBLE CAUSE	SOLUTION
Compressor will not start - no hum	<ol style="list-style-type: none"> <li>1. Line cord not plugged in.</li> <li>2. Fuse removed or blown.</li> <li>3. Overload protector tripped.</li> <li>4. Temp control stuck in open position.</li> <li>5. Wiring improper or loose.</li> </ol>	<ol style="list-style-type: none"> <li>1. Plug in the cord.</li> <li>2. Replace fuse.</li> <li>3. Refer to electrical section.</li> <li>4. Repair or replace temp control.</li> <li>5. Check wiring against diagram.</li> </ol>
Compressor will not start - hums but trips on overload protector.	<ol style="list-style-type: none"> <li>1. Low voltage to unit</li> <li>2. Relay failing to close</li> <li>3. Starting capacitor defective.</li> <li>4. Improperly wired.</li> </ol>	<ol style="list-style-type: none"> <li>1. Determine reason and correct</li> <li>2. Determine reason and correct, replace if necessary</li> <li>3. Determine reason and replace</li> <li>4. Check wiring against diagram</li> </ol>
Compressor starts but does not switch off of start winding.	<ol style="list-style-type: none"> <li>1. Low voltage to unit.</li> <li>2. Relay failing to open.</li> <li>3. Run capacitor defective</li> <li>4. Comp Mt winding is open or shorted</li> </ol>	<ol style="list-style-type: none"> <li>1. Determine reason and correct.</li> <li>2. Determine reason and correct, replace if necessary.</li> <li>3. Determine reason and replace.</li> <li>* 4. Determine cause, correct, and replace comp</li> </ol>
Compressor starts and runs, but short cycles on overload protector.	<ol style="list-style-type: none"> <li>1. Additional current passing through overload protector.</li> <li>2. Low voltage to unit.</li> <li>3. Overload protector defective.</li> <li>4. Run capacitor defective.</li> <li>5. Excessive discharge pressure.</li> <li>6. Compressor too hot - return gas hot.</li> </ol>	<ol style="list-style-type: none"> <li>1. Check wiring diagram. Check for added fan motors, pumps, etc. connected to wrong side of protector.</li> <li>2. Determine reason and correct.</li> <li>3. Check current, replace protector.</li> <li>4. Determine reason and replace.</li> <li>* 5. Check ventilation, restrictions in cooling medium, restrictions in refrigeration system.</li> <li>* 6. Check refrigerant charge (fix leak if necessary). Check air flow across condenser.</li> </ol>
Compressor starts and runs but unit does not begin to cool on initial start-up (MT Bare Tube Condensor Models only)	<ol style="list-style-type: none"> <li>1. Ambient is below 60°F</li> </ol>	<ol style="list-style-type: none"> <li>1. Warm unit to above 60°F prior to initial start-up</li> </ol>
Unit runs OK, but short cycles.	<ol style="list-style-type: none"> <li>1. Overload protector.</li> <li>2. Cold control.</li> <li>3. Overcharge.</li> <li>4. Air in system.</li> <li>5. Undercharge.</li> </ol>	<ol style="list-style-type: none"> <li>1. Check wiring diag for correct wiring</li> <li>2. Differential set too close.</li> <li>* 3. Reduce refrigerant charge.</li> <li>* 4. Recover and recharge.</li> <li>* 5. Fix leak and recharge with refrigerant.</li> </ol>
Unit operates long or continuously.	<ol style="list-style-type: none"> <li>1. Dirty condenser</li> <li>2. Shortage of refrigerant.</li> <li>3. Temp control contacts stuck or frozen</li> <li>4. Evaporator coil iced.</li> <li>5. Restriction in refrigeration system.</li> </ol>	<ol style="list-style-type: none"> <li>* 1. Clean condenser</li> <li>2. Fix leak, add charge, correct charge</li> <li>3. Replace Temp control</li> <li>* 4. Defrost</li> <li>5. Determine location and remove.</li> </ol>
Start capacitor open, shorted or blown.	<ol style="list-style-type: none"> <li>1. Relay contacts not opening properly.</li> <li>2. Low voltage to unit.</li> <li>3. Improper relay.</li> </ol>	<ol style="list-style-type: none"> <li>1. Replace relay</li> <li>2. Determine reason and correct.</li> <li>3. Replace.</li> </ol>
Run capacitor open, shorted or blown.	<ol style="list-style-type: none"> <li>1. Improper capacitor.</li> <li>2. Excessively high line voltage (110% of rated max).</li> </ol>	<ol style="list-style-type: none"> <li>1. Determine correct size and replace.</li> <li>2. Determine reason and correct.</li> </ol>
Relay defective or burned out.	<ol style="list-style-type: none"> <li>1. Incorrect relay.</li> <li>2. Line voltage too high or too low.</li> <li>3. Relay being influenced by loose vibrating mounting.</li> </ol>	<ol style="list-style-type: none"> <li>1. Check and replace.</li> <li>2. Determine reason and replace.</li> <li>3. Remount rigidly.</li> </ol>
Space temperature too high.	<ol style="list-style-type: none"> <li>1. Control setting too high.</li> <li>2. Overcharged with refrigerant.</li> <li>3. Inadequate air circulation.</li> </ol>	<ol style="list-style-type: none"> <li>1. Reset control.</li> <li>* 2. Recover refrigerant and recharge with proper charge specified on dataplate.</li> <li>3. Improve air movement.</li> </ol>
Cooler freezing beverage.	<ol style="list-style-type: none"> <li>1. Temperature control</li> </ol>	<ol style="list-style-type: none"> <li>1. Reset control.</li> </ol>
Unit noisy.	<ol style="list-style-type: none"> <li>1. Loose parts or mountings.</li> <li>2. Tubing rattle.</li> <li>3. Bent fan blade causing vibration.</li> <li>4. Fan motor bearings worn.</li> </ol>	<ol style="list-style-type: none"> <li>1. Find and tighten.</li> <li>2. Reform to be free of contact.</li> <li>3. Replace blade.</li> <li>4. Replace motor.</li> </ol>

ALL SERVICING MUST COMPLY WITH STATE AND FEDERAL REGULATIONS

SALES OFFICE: P.O. BOX 5932, SPARTANBURG, SOUTH CAROLINA 29304  
 PLANTS: SPARTANBURG, SOUTH CAROLINA; HONEA PATH, SOUTH CAROLINA;  
 BROOKVILLE, PENNSYLVANIA

PHONE: 864-582-8111 TOLL FREE: 1-800-845-9800

SHT 1 ILLA-1591 REV. C

**REFRIGERATION SYSTEM**

The Refrigeration System consists of a hermetically sealed compressor and finned evaporator and condenser.

**CONDENSER**

The condenser has wide finned spaces, which allow more air passage with less dirt or dust accumulation. The condenser still requires periodic cleaning for maximum efficiency.

**CONDENSER FAN MOTOR**

The condenser fan motor assembly is mounted between the condenser and the compressor. Air is drawn through the condenser, over the body of the compressor and out the rear of the unit compartment.

The motor is wired to cycle with the compressor but will continue to operate should the compressor cut out on the overload. (The motor is permanently lubricated; therefore, oiling is not required).

**DRIER**

The drier is installed in the system just before the capillary tube. Its purpose is to trap minute particles of foreign material and absorb any moisture in the system.

**LIQUID CONTROL AND HEAT EXCHANGE**

Liquid refrigerant control to the evaporator of the system is accomplished by the use of a capillary tube. This capillary tube is soldered to the suction line to form a heat exchanger which subcools the liquid refrigerant to maintain high efficiency within the system.

**REFRIGERATION SERVICE****EVACUATION**

Moisture in a refrigeration system is directly or indirectly the cause of more problems and complaints than all other factors combined.

When large amounts of moisture are present, system freeze ups will occur. Even in minute amounts, moisture will combine with refrigerants to form an acid. The corrosive action of this acid forms sludge, which will plug the lines and drier.

Since most field type vacuum pumps cannot pull a low enough vacuum to remove all moisture from the system, it is recommended that the system be triple evacuated, breaking each time with dry refrigerant nitrogen. Use care to purge air from the charging hose when breaking the vacuum.

**CHARGING REFRIGERATION SYSTEM**

Since capillary tube systems have small critical refrigerant charges, we recommend that a field charge either be weighed in or put in from a portable charging cylinder. After maximum vacuum has been obtained as detailed above, attach charging cylinder to the system line making sure to purge air from hose with refrigerant. With the unit running, allow refrigerant to run slowly into the system until the desired charge is reached. When using Refrigerant Blends it is recommended to liquid charge into the high side of the system with the initial charge and then any remaining charge can be put into the suction side; however, care must be taken to meter the remaining amount into the low side so as not to cause excess liquid to go into the compressor.

**OVERCHARGE**

When the cabinet has pulled down to operating temperature, an indication of an overcharge is that the suction line will be cooler than normal with the compressor running. Running time will be higher than normal. Suction line will sweat or frost.

Reclaim excessive refrigerant from the system very carefully in small amounts waiting several minutes for the system to balance.

**UNDERCHARGE**

An undercharge or shortage of refrigerant will result in any of the following:

1. Lower than normal head pressure.
2. Lower than normal suction pressure.
3. Excessive or continuous operation of compressor.
4. Higher than normal cabinet temperature.

**FEDERAL LAW REQUIRES THAT REFRIGERANTS BE RECOVERED PRIOR TO SERVICING.**



