



IMPORTANT INFORMATION FOR E/P SERIES

ER/EF / PRI/PFI / PRD
PR/PF / PRT / PRF

**This cooler has passed the
QUALITY CONTROL INSPECTION
and meets the high standards at Beverage-Air.
This inspection includes complete refrigeration
system, cabinet construction & finish.**

**IMPORTANT
PLEASE RETAIN FOR YOUR RECORDS**

**SALES OFFICE: P.O. BOX 5932 SPARTANBURG, S.C. 29304-5932
PHONE: (864) 582-8111 TOLL FREE 1-888-845-9800
TECHNICAL SERVICE: 1-800-684-1199, PARTS ORDER FAX: 1-800-262-9381
24 HOUR WARRANTY SERVICE CENTER 1-877-866-1223
PLANTS: SPARTANBURG, S.C. BROOKVILLE, PA. HONEA PATH, S.C.**



BEVERAGE-AIR[®]

INSTALLATION AND OPERATING INSTRUCTIONS

1. INSTALLATION

- a. Receiving Inspection:
Upon receipt, check all packages for accessories or optional components, including legs, caster, shelves or pan slides. Keys for door locks are attached to one of the doors. (When lock is installed.)
- b. Legs & Casters:
Each cabinet is provided with four threaded legs or casters shipped separately. Legs and casters screw directly into the weld nut provided in each corner of the base. (See Fig. #1)
- c. Leveling:
To provide adequate defrost drainage and proper door alignment and operation, it is necessary that the cabinet be level. Level cabinet from front to rear and from side to side by adjusting leg inserts. This should be done after cabinet has been set in its final operating position.
- d. Pilasters and Air Ducts:
Pilaster and air ducts are secured to the inside of the cabinet with thumb screws to permit removal without tools, for cleaning. Before operation, loosen all thumb screws and retighten with fingers to facilitate later cleaning. Down duct(s) are shipped in place and may be removed by lifting up and pulling forward after return air and back duct are removed.
- e. Shelves:
Included are three epoxy coated wire shelves per door opening (3 per 24, 6 per 48, 9 per 74). Also included are 3 epoxy coated filler shelves per 48 and 6 per 74. Shelf spacing is adjustable with enclosed shelf supports to suit requirements. (See Fig. #2)
- f. Locating Cooler:
Provide at least three inches of space between cabinet and any adjacent wall or fixture, at left end and rear of cabinet.

2. OPERATION

- a. Electrical Supply & Connections:
A wiring diagram is permanently affixed to the front of the evaporator housing. It is important that the cabinet be connected into a separate single circuit. Before connecting cabinet, check line voltage to assure it is compatible with the voltage specified on the data plate. (See Fig. #4). Low line voltage is often the cause of service complaints. Wiring should be sufficient to carry the electrical load and to meet local codes. A qualified electrician should make the necessary electrical connections. Be sure cabinet is properly grounded. Check supply voltage after unit has started to be sure circuit is not overloaded.

208/230V Field Wired Unit
Cabinet must be connected to a 208/230V/60Hz grounded supply. Prior to connecting power, ensure voltage between any supply conductor and neutral is 115V. Failure to properly wire unit will void all warranties and may result in property damage.
- b. Compressor Mounts: (Freezer Models Only)
The compressor is secured with steel banding at the factory to prevent damage during shipping (See Fig. #4). Before operating compressor cut the banding and remove #4. This will allow free movement of the compressor while unit is running.
- c. Initial Start-Up:
Turn power on and check to verify that compressor and condenser fan are running. (See Fig. #4) On freezers, evaporator fans are delayed in starting until the evaporator temperature has pulled down to 25°F. Once fans are running, a switch behind each door will stop fans while door is open.
- d. Interior Lights:
Each cabinet has interior lights actuated by a door switch.
- e. Defrost System and Condensate Disposal:
The defrost timer and temperature control are located on the top front of cabinet, behind the grille. For access to these components, remove grille by lifting up and out. (See Fig. 3) Freezers are provided with an electric defrost heater actuated by the defrost timer. The defrost timer clock provides for one to four defrost cycles per 24 hour period. The timer is factory set for four defrost cycles per 24 hour period to occur at 12 midnight, 6 a.m., 12 noon and 6 p.m. When the freezer is placed in service the clock must be set to the time of day. The defrost cycle is normally temperature-terminated by an internal control switch. However, the defrost on-time is limited to 30 minutes by a separate setting. To set back up defrost termination, push down and rotate pointer on inside (2 hour) dial until it is opposite desired time. Refrigerators do not have a defrost timer. However, defrosting occurs automatically with each cycle of the compressor. All cabinets are equipped with an automatic overhead condensate disposal system. No outside drain hook up is necessary.
- f. Temperature Control:
Factory setting of control is at No. 4 position. For Freezer, No. 4 setting will maintain the product at about 0°F. For colder cabinet temperatures, turn knob clockwise, one number at a time, allowing one hour for temperature to stabilize. No. 7 position will maintain the product at about -10°F. For Refrigerator No. 4 setting will maintain the product at about 36°F. No. 7 position will maintain the product at about 32°F. Excessive tampering with the control could lead to service difficulties. For operation above 3,000 ft. altitude, have thermometer adjusted by qualified serviceman.

3. MAINTENANCE

a. Cleaning Cabinet Exterior:

Cabinets should be cleaned with a solution of mild soap and water. Do not use caustic soap or abrasive cleaners, since these might damage the cabinet finish. If stainless steel surfaces become discolored, scrub by rubbing only in direction of the finish grain. The anodized aluminum interior and exterior should be cleaned with mild soap and water. Do not use steel wool.

b. Cleaning Interior Surfaces:

The inside of the cabinet is coated with baked-on vinyl or stainless steel. To clean, use mild soapy water and cloth, or sponge. Air baffles and air ducts are mounted with thumb screws to facilitate removal, without tools, for cleaning.

c. Condenser:

For efficient operation, it is recommended that the condenser coil and fans be cleaned every 4 to 6 months. Remove grille for access. Vacuum clean front surface of coil thoroughly, or direct forced air through condenser from the rear. If necessary, use a stiff bristled brush to loosen dirt.

d. Condensate Evaporation Pan:

The condensate evaporation pan (See Fig. 4) must be cleaned periodically to prevent foul odors and to operate efficiently. Vacuum clean if dry, or sponge clean with soapy water.

4. SERVICING

All Beverage-Air products are inspected and performance tested at the factory before crating to insure years of satisfactory operation. However, in time, minor servicing will be necessary to maintain or restore peak performance of the cabinet in particular applications. Problems usually encountered and their corrections are as follows.

Problem: High temperature.

Correction: (1) Inside air duct might be blocked with product. Be sure space between shelves, in center of cabinet, is open for proper air circulation. (2) Very high usage, or door left open, can raise temperature. Give cabinet time to pull back down. (3) Cabinet might be in defrost cycle; check timer box for position of cam. (4) Condenser could be clogged with dirt, cutting down air flow. Check and clean, if dirty.

Problem: Doors will not close properly.

Correction: (1) Door hinges, particularly on bottom, can get dry and caked with dirt, Etc. Clean, if needed, and lubricate wear surfaces lightly. (2) If cabinet has been moved, it might not be level. Relevel, if needed.

In case additional service is required, a qualified service agency or the factory should be contacted. When calling for service at the factory, be prepared to give serial and model numbers of the cabinet to insure prompt attention.

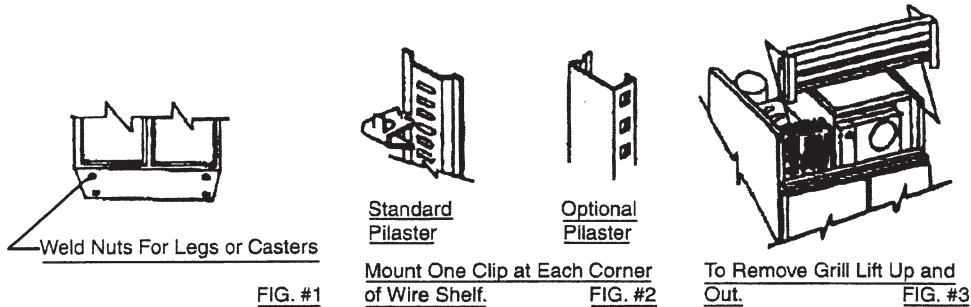

- 1. Condenser
- 2. Condensate Evaporator Pan
- 3. Compressor
- 4. Compressor Mounting Band
- 5. Junction Box (Compressor)
- 6. Starting Relay (Freezer)
- 7. Evaporator
- 8. Defrost Timer (Freezer)
- 9. Temperature Control
- 10. Data Plate
- 11. Wiring Diagram
- 12. Condenser Fans

FIG. #4

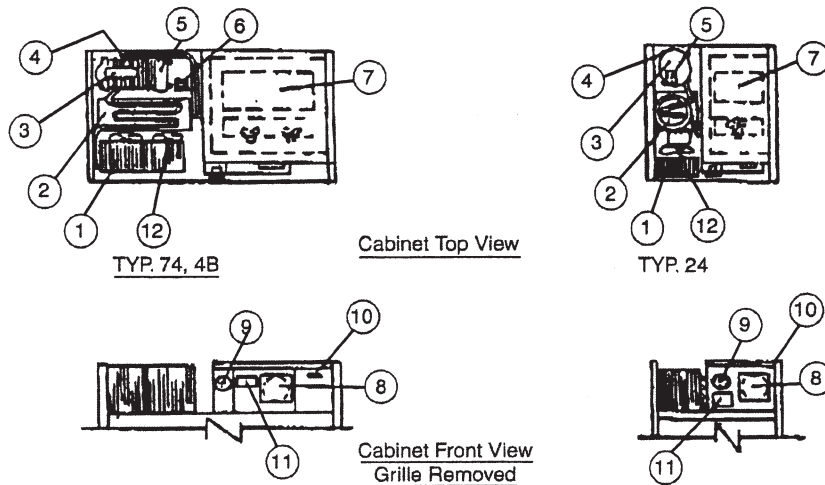

Effective Methods for Cleaning Stainless Steel

	Cleaning Agent •	Method of Application ••	Effect on Finish
Routine Cleaning	Soap or ammonia, or detergent and water.	Sponge with cloth, then rinse with clear water and wipe dry.	Satisfactory for use on all finishes.
Smears and Fingerprints	Arcal 20, Lac-O-Nu, Lumin Wash O'Cedar Cream Polish, Stainless Shine	Rub with cloth as directed on the package.	Satisfactory for use on all finishes. Provides barrier film to minimize prints.
Stubborn Spots and Stains Baked-On Splatter, and Other Light Discolorations	Allichem Concentrated Cleaner.	Apply with damp sponge or cloth.	Satisfactory for use on all finishes.
	Samae, Twinkle or Cameo Copper Cleaner.	Rub with damp cloth.	Satisfactory for use on all finishes if rubbing is light.
	Grade FFF Italian pumice whitening or talc.	Rub with damp cloth.	Use in direction of polish lines on No. 4 (polished) finish. Use light pressure on No. 2 (mill) finishes, and Nos. 7 and 8 (polished) finishes.
	Liquid NuSteel.	Rub with dry cloth. Use small amount of cleaner.	Use in direction of polish lines on No. 4 (polished) finish. May scratch No. 2 (mill) and Nos. 7 and 8 (polished) finishes.
	Paste NuSteel or DuBois Temp.	Rub with dry cloth. Using a small amount of cleaner.	Use in direction of polish lines on No. 4 (polished) finish. May scratch No. 2 (mill) and Nos. 7 and 8 (polished) finishes.
	Copper's Stainless Steel Cleaner Revere Stainless Cleaner.	Copper's Stainless Steel Cleaner Revere Stainless Cleaner.	Use in direction of polish lines on No. 4 (polished) finish. May scratch No. 2 (mill) and Nos. 7 and 8 (polished) finishes.
	Household cleansers, such as Old Dutch, Lighthouse Sunbrite, Wyandotte, Bab-O, Gold Dust, Sapolio, Bon Ami, Ajax or Comet.	Rub with a damp cloth. May contain chlorine bleaches. Rinse thoroughly after use.	Use in direction of polish lines on No. 4 (polished) finish. May scratch No. 2 (mill) and Nos. 7 and 8 (polished) finishes.
	Grade F Italian pumice, Steel Bright, Lumin Cleaner, Zud, Restoro, Sta-Clean, or Highlite.	Rub with a damp cloth.	Use in direction of polish lines on No. 4 (polished) finish. May scratch No. 2 (mill) and Nos. 7 and 8 (polished) finishes.
Heat Tint or Heavy Discoloration	Penny-Brite or Copper-Brite.	Rub with a dry cloth.	Use in direction of polish lines on No. 4 (polished) finish. May scratch No. 2 (mill) and Nos. 7 and 8 (polished) finishes.
	Past NuSteel, Dubois Temp or Tarnite.	Rub with a dry cloth or stainless steel wool.	Use in direction of polish lines on No. 4 (polished) finish. May scratch No. 2 (mill) and Nos. 7 and 8 (polished) finishes.
	Revere Stainless Steel Cleaner.	Apply with damp sponge or cloth.	Use in direction of polish lines on No. 4 (polished) finish. May scratch No. 2 (mill) and Nos. 7 and 8 (polished) finishes.
	Allen Polish, Steel Bright, Wyandotte, Bab-O, or Zud.	Rub with a damp cloth.	Use in direction of polish lines on No. 4 (polished) finish. May scratch No. 2 (mill) and Nos. 7 and 8 (polished) finishes.
Burnt-On Foods and Grease Fatty Acids, Milkstone (where swabbing or rubbing is not practical)	Easy-Off, De-Grease-It, 4 to 6% hot solution of such agents as trisodium phosphate or sodium tripolyphosphate or 5 to 15% caustic soda solution.	Apply generous coating. Allow to stand for 10-15 minutes. Rinse. Repeated application tripolyphosphate or 5 to 15% may be necessary.	Excellent removal, satisfactory for use on all finishes.
Tenacious Deposits, Rusty Discolorations, Industrial Atmospheric Stains	Oakite No.33, Dilac Texo 12, Texo N.Y., Flash-Klenz, Caddy Cleaner, Turco Scale 4368 or Permag 57.	Swab and soak with clean cloth. Let stand 15 minutes or more according to directions on package, then rinse dry.	Satisfactory for use on all finishes.
Hard Water Spots and Scale	Vinegar.	Swab or wipe with cloth. Rinse with water and dry.	Satisfactory for use on all finishes.
	5% oxalic acid, 5% sulfamic acid, 5 to 10% phosphoric acid, or Dilac, Oakite No.33, Texo 12, Texo N.Y.	Swab or soak with cloth. Let stand 10-15 minutes. Always follow with neutralizer rinse, and dry.	Satisfactory for use on all finishes. Effective on tenacious deposits or where scale has built up.

NOTES

- Use of proprietary names is intended only to indicate a type of cleaner, and does not constitute an endorsement, nor is omission of any cleaner to imply its inadequacy. It should be emphasized that all products should be used in strict accordance with instructions on package.
- In all applications a stainless steel wool or sponge or fibrous brush or pads are recommended. Avoid use of ordinary steel wool or steel brushes for scouring stainless steel.

SUGGESTIONS:

- Use the mildest cleaning procedure that will do the job effectively.
- Rub in the direction of polish line for maximum effectiveness and to avoid marring the surface.
- Rinse thoroughly with fresh water after every cleaning operation.
- Wipe dry to avoid water marks.

Cleaning data supplied by AISI

Reprinted Courtesy by The House of Stainless, Inc., Chicago, Ill

ILA-1265
Instructions for SS Cleaning



BEVERAGE-AIR.

Spartanburg, South Carolina
Brookville, Pennsylvania

SERVICE AND ANALYSIS CHART

REFRIGERATION SYSTEM

MALFUNCTION

POSSIBLE CAUSE

SOLUTION

Compressor will not start — no hum

1. Line cord not plugged in.
2. Fuse removed or blown.
3. Overload protector tripped.
4. Control stuck in open position.
5. Wiring improper or loose.

1. Plug in line cord.
2. Replace fuse.
3. Refer to electrical section.
4. Repair or replace control.
5. Check wiring against diagram.

Compressor will not start — hums but trips on overload protector

1. Improperly wired.
2. Low voltage to unit.
3. Starting capacitor defective.
4. Relay failing to close.

1. Check wiring against diagram.
2. Determine reason and correct.
3. Determine reason and replace.
4. Determine reason and correct, replace if necessary.

Compressor starts, but does not switch off of start winding

1. Low voltage to unit.
2. Relay failing to open.
3. Run capacitor defective.
4. Compressor motor has a winding open or shorted.

1. Determine reason and correct.
2. Determine reason and correct, replace if necessary.
3. Determine reason and replace.
4. Replace compressor.

Compressor starts and runs, but short cycles on overload protector

1. Additional current passing through overload protector.
2. Low voltage to unit.
3. Overload protector defective.
4. Run capacitor defective.
5. Excessive discharge pressure.
6. Compressor too hot — return gas hot.

1. Check wiring diagram. Check for added fan motors, pumps, etc., connected to wrong side of protector.
2. Determine reason and correct.
3. Check current, replace protector.
4. Determine reason and replace.
5. Check ventilation, restrictions in cooling medium, restrictions in refrigeration system.
6. Check refrigerant charge (fix leak) add if necessary

Unit runs OK, but short cycles

1. Overload protector.
2. Cold control.
3. Overcharge.
4. Air in system.
5. Undercharge.

1. Check wiring diagram.
2. Differential set too close — widen.
3. Reduce refrigerant charge.
4. Purge and recharge.
5. Fix leak, add refrigerant.

Unit operates long or continuously

1. Shortage of refrigerant.
2. Control contacts stuck or frozen closed.
3. Evaporator coil iced.
4. Restriction in refrigeration system.
5. Dirty condenser.

1. Fix leak, add charge.
2. Clean contacts or replace control.
3. Defrost.
4. Determine location and remove.
5. Clean condenser.

Start capacitor open, shorted or blown

1. Relay contacts not opening properly.
2. Low voltage to unit.
3. Improper relay.

1. Clean contacts or replace relay if necessary.
2. Determine reason and correct.
3. Replace

Run capacitor open, shorted or blown

1. Improper capacitor.
2. Excessively high line voltage. (110% or rated-max.).

1. Determine correct size and replace.
2. Determine reason and correct.

Relay defective or burned out

1. Incorrect relay.
2. Line voltage too high or too low.
3. Relay being influenced by loose vibrating mounting.

1. Check and replace.
2. Determine reason and correct.
3. Remount rigidly.

Space temperature too high

1. Control setting too high.
2. Improper overcharge.
3. Inadequate air circulation.

1. Reset control.
2. Purge.
3. Improve air movement.

Cooler freezing beverage

1. Control setting.

1. Reset control.

Unit noisy

1. Loose parts or mountings.
2. Tubing rattle.
3. Bent fan blade causing vibration.
4. Fan motor bearings worn.

1. Find and tighten.
2. Reform to be free of contact.
3. Replace blade.
4. Replace motor.



BEVERAGE-AIR

SALES OFFICE: P.O. BOX 5932, SPARTANBURG, SOUTH CAROLINA 29304
 PLANTS: SPARTANBURG, SOUTH CAROLINA • BROOKVILLE, PENNSYLVANIA
 PHONE 803-582-8111 TOLL FREE NUMBER 1-800-845-9800

REFRIGERATION SYSTEM

SERVICE AND ANALYSIS CHART

■ REFRIGERATION SYSTEM

The Refrigeration System consists of a 115v. 60 Hz. hermetically sealed compressor, finned evaporator and condenser.

■ CONDENSER

The condenser has wide finned spaces which allow more air passage with less dirt or dust accumulation. The condenser still requires periodic cleaning for maximum efficiency.

■ CONDENSER FAN MOTOR

The condenser fan motor assembly is mounted between the condenser and compressor. Air is drawn through the condenser, over the body of the compressor and then out the rear of the unit compartment.

The motor is wired to cycle with the compressor but will continue to operate should the compressor cut out on the overload. (The motor is permanently lubricated; therefore, oiling is not required).

■ DRIER

The drier is installed in the system just before the capillary tube. Its purpose is to trap minute particles of foreign material and absorb any moisture in the system.

■ LIQUID CONTROL AND HEAT EXCHANGE

Liquid refrigerant control to the evaporator of the system is accomplished by the use of a capillary tube or expansion valve. This capillary tube or liquid line is soldered to the suction line to form a heat exchanger which subcools the liquid refrigerant to maintain high efficiency within the system.

■ REFRIGERATION SERVICE EVACUATION

Moisture in a refrigeration system is directly or indirectly the cause of more problems and complaints than all other factors combined.

When large amounts are present, system freeze ups will occur. Even in minute amounts, moisture will combine with refrigerants to form hydrochloric acid. The corrosive action of this acid forms sludge which will plug the lines and drier.

Only a vacuum pump should be used for evacuation because operating the compressor in a deep vacuum could cause serious damage to the compressor windings.

Since most field type vacuum pumps cannot pull a low enough vacuum to remove moisture from the system, it is recommended that the system be triple evacuated, breaking each time with dry refrigerant. Use care to purge air from the charging hose when breaking the vacuum. After third vacuum, backseat valves and proceed with replacement charge.

■ CHARGING REFRIGERATION SYSTEM

Since capillary tube systems have small critical refrigerant charges, we recommend that a field charge either be weighed in or put in from a portable charge board. After maximum vacuum has been obtained as detailed above, attach charging cylinder to the suction line making sure to purge air from hose with refrigerant- With the unit running, allow refrigerant to run slowly into the system until the desired charge is reached.

OVERCHARGE

When the cabinet has pulled down to operating temperature an indication of an overcharge is that the suction line will be cooler than normal with the compressor running. Running time will be higher than normal. Suction line will sweat or frost.

Purge excessive refrigerant from the system very carefully in small amounts waiting several minutes for the system to balance.

When correct charge has been obtained with cabinet at operating temperature, several seconds after compressor has started after cycle, suction line will frost and remain frosted for approximately (60) seconds.

UNDERCHARGE

An undercharge or shortage of refrigerant will result in any or all of the following:

1. Lower than normal head pressure.
2. Lower than normal suction pressure.
3. Excessive or continuous operation of compressor.
4. Higher than normal cabinet temperature.

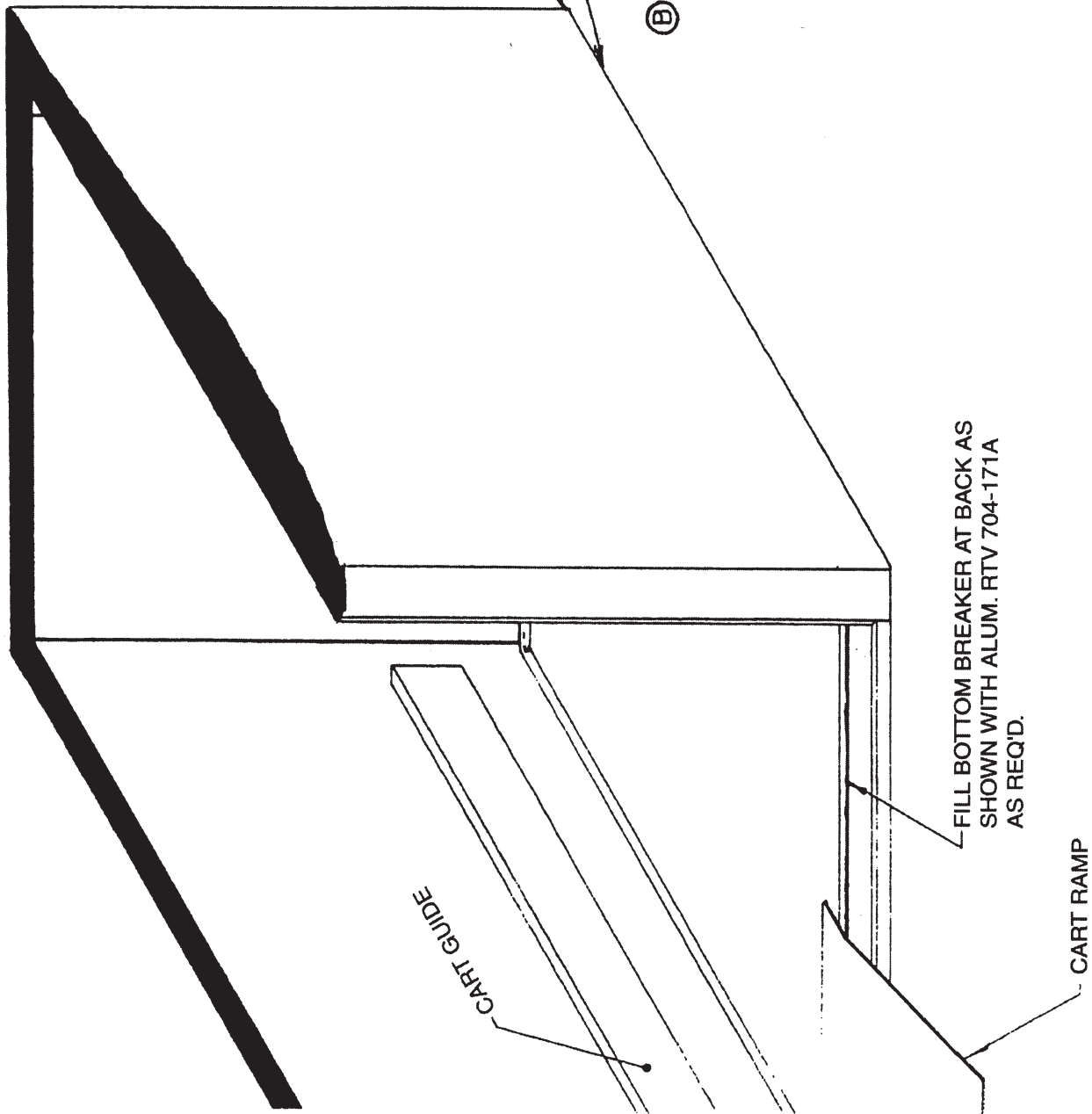

WHEN COOLER IS INSTALLED AT LOCATION, BOTTOM AND SIDE SURFACES MUST BE SEALED TO FLOOR BY RTV OR OTHER SEALER. THIS IS TO PREVENT CORROSION OF BOTTOM.

(B)

FILL BOTTOM BREAKER AT BACK AS SHOWN WITH ALUM. RTV 704-171A AS REQ'D.

CART GUIDE

CART RAMP

SHELF CLIP INSTALLATION

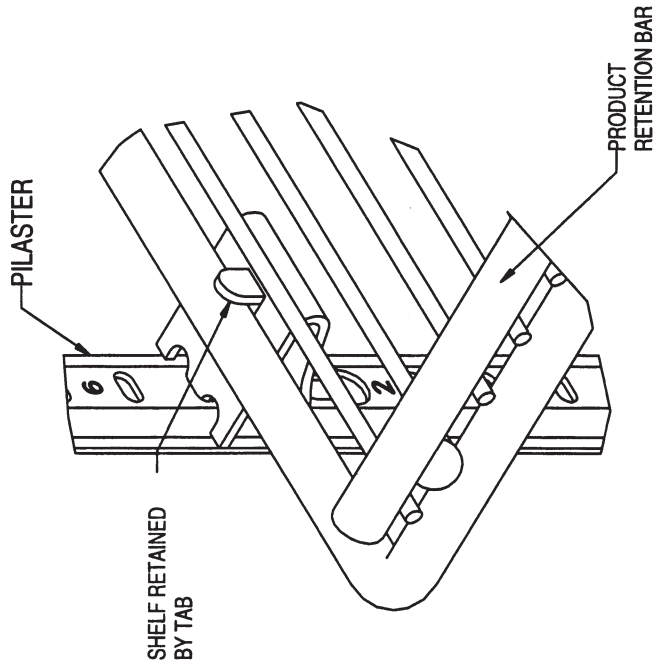
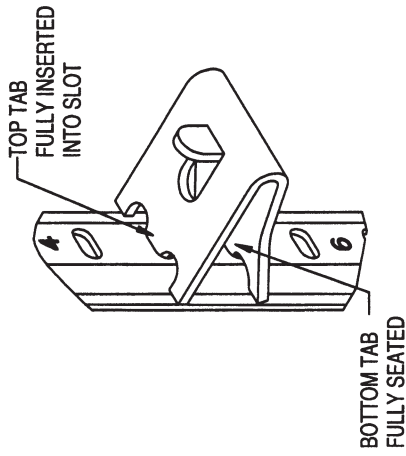
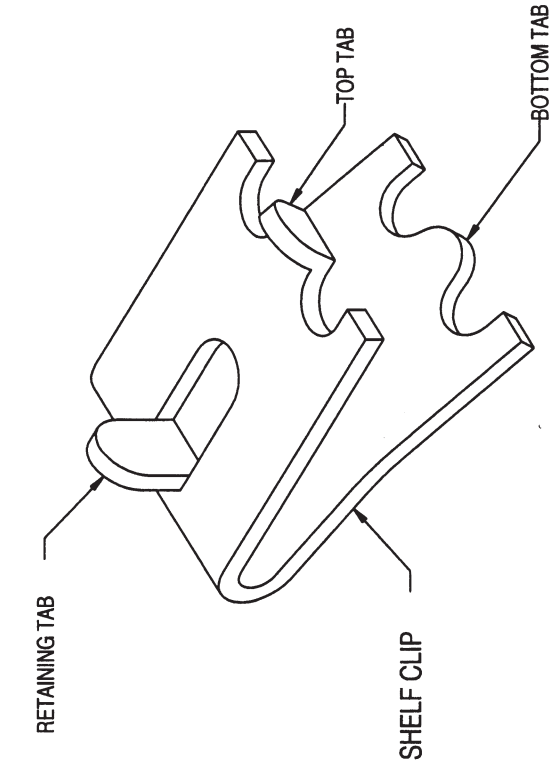

INSTALLATION INSTRUCTIONS

- 1) DETERMINE PROPER LOCATION FOR SHELF CLIPS. THE REFERENCE NUMBERS ON THE PILASTER CAN SERVE AS A GUIDE TO ENSURE ALL CLIPS ARE PROPERLY LOCATED.
- 2) INSERT TOP TAB OF THE SHELF CLIP INTO THE DESIRED HOLE OF THE PILASTER. THE RETAINING TAB SHOULD BE FACING UPWARDS AS SHOWN.
- 3) ROTATE THE CLIP DOWNWARDS AND INSERT THE BOTTOM TAB INTO THE APPROPRIATE HOLE ON THE PILASTER. THE CLIP MAY NEED TO BE SQUEEZED SLIGHTLY DURING INSTALLATION.
- 4) INSTALL ALL REMAINING CLIPS AS DESCRIBED ABOVE.
- 5) INSTALL SHELVES ONTO CLIPS WITH THE PRODUCT RETENTION BAR FACING UPWARD. BE CAREFUL NOT TO DISLodge CLIPS DURING SHELF INSTALLATION.
- 6) SHELVES MUST BE PLACED SUCH THAT THE RETAINING TAB ON THE SHELF CLIP CAPTURES THE SHELF AS SHOWN.
- 7) PRIOR TO LOADING THE SHELF, ENSURE THAT THE SHELF IS RESTING ON EACH OF 4 CLIPS AND THE CLIPS ARE INSTALLED AS SHOWN.

WARNING

- IMPROPER SHELF CLIP INSTALLATION MAY CAUSE SHELF AND/OR PRODUCT TO FALL RESULTING IN DAMAGE TO THE UNIT AND BODILY INJURY.
- DO NOT OVERLOAD THE SHELVES. THE UNIT IS DESIGNED TO UTILIZE ALL SHELVES THAT ARE SUPPLIED IN AN EQUALLY SPACED MANNER. IF LESS SHELVES OR A DIFFERENT CONFIGURATION IS DESIRED, CONTACT THE MANUFACTURER TO ENSURE SHELF OVERLOADING WILL NOT OCCUR.

Bi-pin Fluorescent Lamp Installation / Verification

Prior to applying power to the unit, verify that all lamps are properly installed and fully engaged in the lamp holders.

Proper lamp engagement is achieved by rotating the lamp 90° from its insertion position until it “snaps” or “clicks” into place.

Visual verification can be made on units without safety shields by using the identification mark on the end of the bulb. Properly installed bulbs will have the mark centered between the “halves” of the lamp holder.

On units with shields, the identification mark cannot be seen. Physically verify that the lamp has been rotated and locked into place.

See pictures below.

Caution: Improperly installed lamps may cause damage to the lighting circuit. Beverage-Air shall have no liability whatsoever for equipment or component failures or other damages or losses which arise as a result of improper installation.

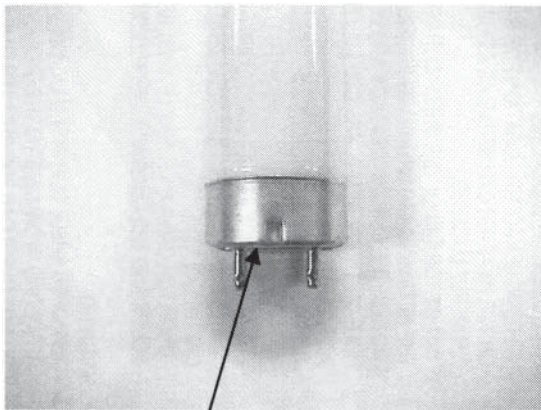

Bi-pin lamp end
Identification mark

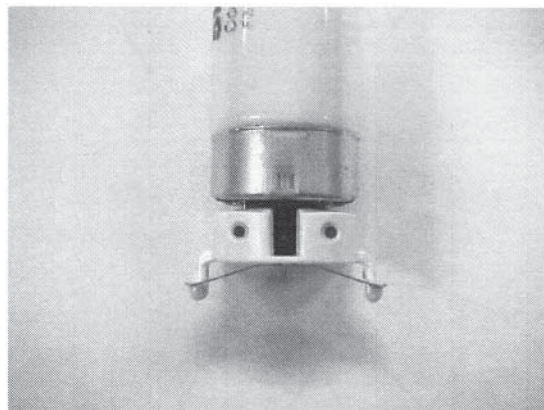

Properly installed lamp without shield. Verify
identification mark is positioned as shown.

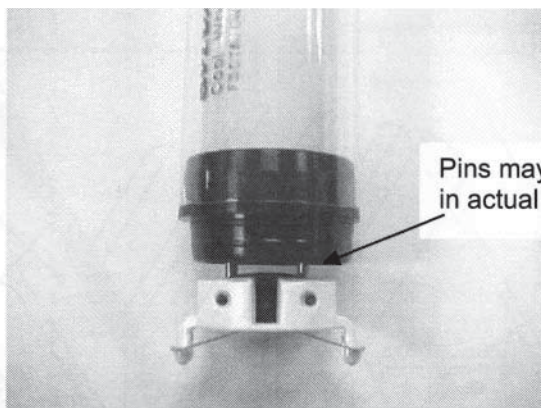

Properly installed lamp with shield .
Requires physical verification that lamp has
been rotated and locked into place.

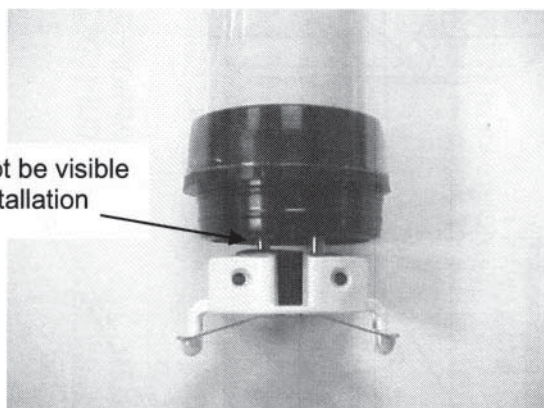

Improperly installed lamp with shield.
Note that pins have not achieved full 90° rotation.

