

CODE
BG21361BUC00 Solid Front-No Window
BG21362BUC00 With Window



**BG2136
CONVEYOR OVEN
REPLACEMENT PARTS MANUAL
(with WIRING DIAGRAMS)**



EFFECTIVE with SERIAL #401811005 and AFTER

Serial # Code
First 4 digits - order of production
Fifth digit - model specific
Sixth and Seventh digit - month of production
Eighth and Ninth digit - year of production

Table of Contents: Page 2

BLODGETT CONVEYOR OVENS, 1400 Toastmaster Drive, Elgin, IL 60120
Telephone: 847-741-3300 • Fax Number 847-741-4406

www.blodgett.com

email: techsupport@middleby.com

Table of Contents

Spec Sheet	3
Key Parts	5
View of Installation Kit	6
Parts for Installation Kit.....	7
Stacking Kit (Older SG over BG) Instructions	8
Parts for Stacking Kit.....	9
View of Panels, End Plugs and Window	10
Parts for Panels, End Plugs and Window	11
View of Right-hand Electrical Compartment	12
Parts for Right-hand Electrical Compartment	13
View of Left-hand Electrical & Gas Train Compartment.....	14
Parts for Left-hand Electrical & Gas Train Compartment	15
View of Rear Compartment and Blowers	16
Parts for Rear Compartment and Blowers	17
View of Single-Belt Conveyor	18
Parts for Single-Belt Conveyor	19
View of Split-Belt Conveyor	20
Parts for Split-Belt Conveyor	21
Standard Finger Placement and Part Numbers 45476B.....	22
Noble Roman Finger Placement and Part Numbers 58686B.....	23
Wiring Diagrams (electrical schematics)	
Blodgett Model # BG2136 208;240 volt 50/60 Hz, 1 Phase ENG/GM/FR/SP 55553C	24
Blodgett Model # BG2136 208;240 volt 50/60 Hz, 1 Phase IT/GR/DN/DU 55551C	25



MODELS BE2136 & BG2136 Electric/Gas Conveyor Oven



- OPTIONS AND ACCESSORIES**
(AT ADDITIONAL CHARGE)
- Stacking Kit-Stack new oven on Top of SG series
 - High speed conveyor (1-10 minutes)
 - Twin belt with individually adjustable speed settings
 - One year additional extended warranty*
 - Solid Front



Project _____
 Item No. _____
 Quantity _____

BE2136 & BG2136

Blodgett conveyor oven with 18" (508mm) wide conveyor assembly and 36" (915mm) baking zone length. Single, double or triple stack models.

All data is shown per oven section, unless otherwise indicated.

EXTERIOR CONSTRUCTION

- Stainless steel front, top, sides, and interior
- Aluminized steel back
- Full drop down front window

INTERIOR CONSTRUCTION

- Stainless steel outer plates
- Stainless steel wire mesh conveyor belt assembly
- Two blower inlets in the plenum for air circulation
- Upper and lower air fingers

OPERATION

- Heat transferred through forced convection (impingment)
- Open vented baking compartment
- Solid state digital controls to display set point and actual temperature as well as belt speed
- Electronic spark ignition control system (gas model)
- Atmospheric type burner (gas model)
- Internal gas pressure regulator (gas model)
- Tubular resistance elements (electric model)
- Solid state speed control with motor feedback
- Two circulation blower motors
- 3-30 minute bake time

STANDARD FEATURES

- Patented energy efficient system that improves cooking results and saves energy
- Front mounted digital control
- Large front loading door with window and stainless steel handle
- Folding removable conveyor belt assembly
- Adjustable belt tensioning feature
- Field reversible belt direction
- One 8" extension tray
- Product stop
- 48" flexible gas hose (gas units only)
- Lower shelf on single and double stack ovens
- 6' cord with NEMA #L6-20P plug (gas model)
- 3/4" NPT
- Oven start-up*
- One year parts & labor warranty*

* For all international markets, contact your local distributor.



MODEL BE2136 & BG2136

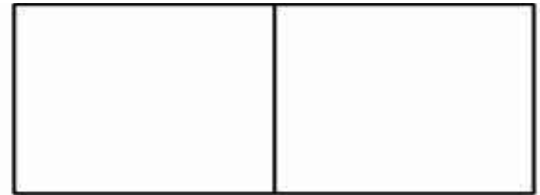

APPROVAL/STAMP

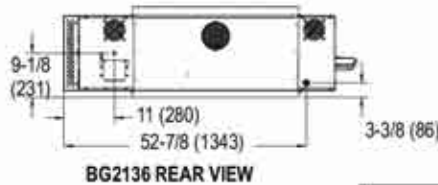
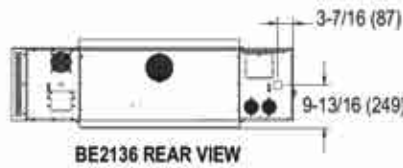
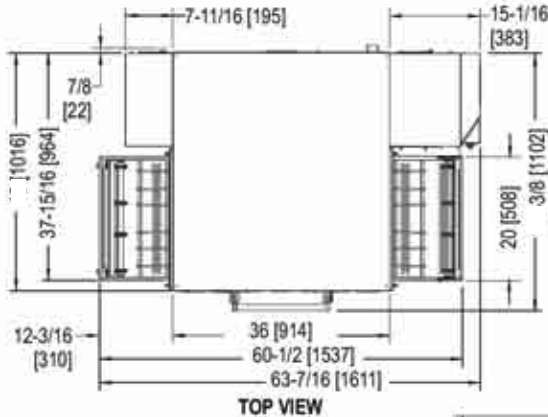

DIMENSIONS ARE IN INCHES [MM]

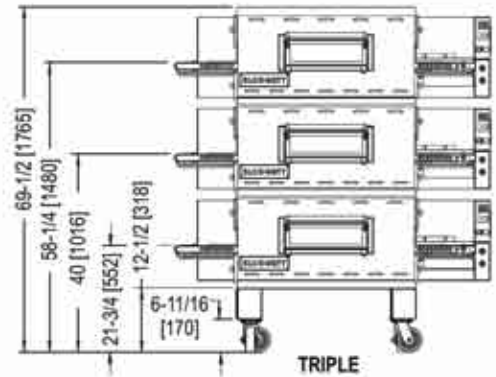
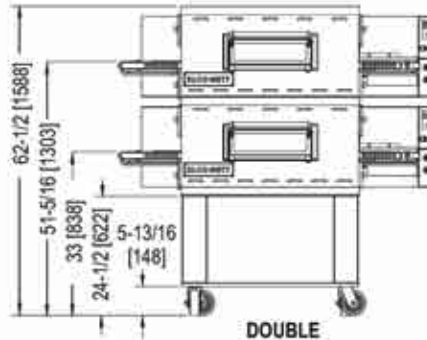
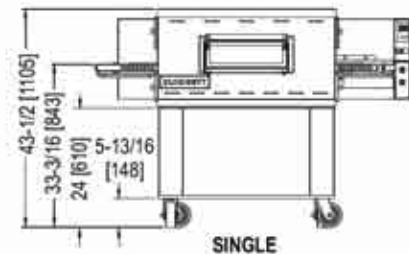
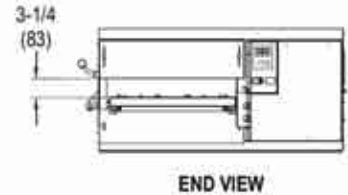

SHORT FORM SPECIFICATIONS

Provide Blodgett conveyor model BE2136 (electric) or BG2136 (gas) conveyor oven. Unit shall cook by means of forced, heated air. Unit shall be (single/double/triple) deck. Each deck shall be fully independent, of stainless steel construction, and fully insulated on all sides. Provide with (electronic spark ignition gas fired/electrically heated) baking compartment with two blowers to evenly distribute heat across baking zone. Conveyor belts shall be single - 18" (457mm) belt constructed of stainless steel wire mesh; baking zone length shall be 36" (915mm). Unit shall be provided with drop down front window. Control panel shall be solid state with 550°F (288°C) maximum thermostat and LCD display of 3-30 minutes adjustable belt speed. Provide start-up inspection service by a factory authorized service agent. Provide options and accessories as indicated.

DIMENSIONS:

Floor space	60" (1524mm) W x 43" (1092mm) L		
Product clearance	3-1/4" (83mm)		
Combustible wall clearance	Left	Right	Rear
BE2136	1" (25mm)	1" (25mm)	3" (76mm)
BG2136	1" (25mm)	1" (25mm)	3" (76mm)
Baking zone			
Width	20" (508mm)		
Length	36" (914mm)		

MAXIMUM INPUT: (per section)

BE2136	17 kW
BG2136	75,000 BTU/hr (22 KW) (79 MJ/hr)

GAS SUPPLY: (specify)

	Natural	Propane
Oven per cavity	NPT	NPT
Main gas supply	2" line	1-1/2" line
Minimum Gas Pressure:	6" W.C.	11.0" W.C.
Maximum Gas Pressure:	12" W.C.	14" W.C.

NOTE: Blodgett Oven, in accord with its policy to continually improve its products, reserves the right to change materials or specifications without notice. Such revisions do not entitle the buyer to corresponding changes, improvements, additions, or replacements for previously purchased equipment.

POWER SUPPLY (must have dedicated ground)

BE2136			
Domestic	208 VAC, 50/60 hz, 3 ph, 54 amp, 17 kW, 3-wire plus gnd	240 VAC, 50/60 hz, 3 ph, 47 amp, 17 kW, 3-wire plus gnd	
International	380 VAC, 50/60 hz, 3 ph, 32 amp, 17 kW, 3-wire plus N and gnd	480 VAC, 50/60 hz, 3 ph, 27 amp, 17 kW, 3-wire plus N and gnd	
CE	380 VAC, 50/60 hz, 3 ph, 32 amp, 17 kW, 3-wire plus N and gnd		
BG2136			
All	208-240 VAC, 50/60 Hz, 1 ph, 6 amp., 2-wire plus ground		

MINIMUM ENTRY CLEARANCE:

Uncrated 19-1/2" (495mm)

SHIPPING INFORMATION:

Approx. Weight:	
Single	658 lbs. (299 kg)
Double	1255 lbs. (570 kg)
Triple	2449 lbs. (1112 kg)
Crate Size:	
BE2136	
BG2136	

BLODGETT OVEN COMPANY

www.blodgett.com • 1400 Toastmaster Drive, Elgin, IL USA 60120 • Phone: (847) 741-3300 • Fax: (847) 741-0015

KEY PARTS

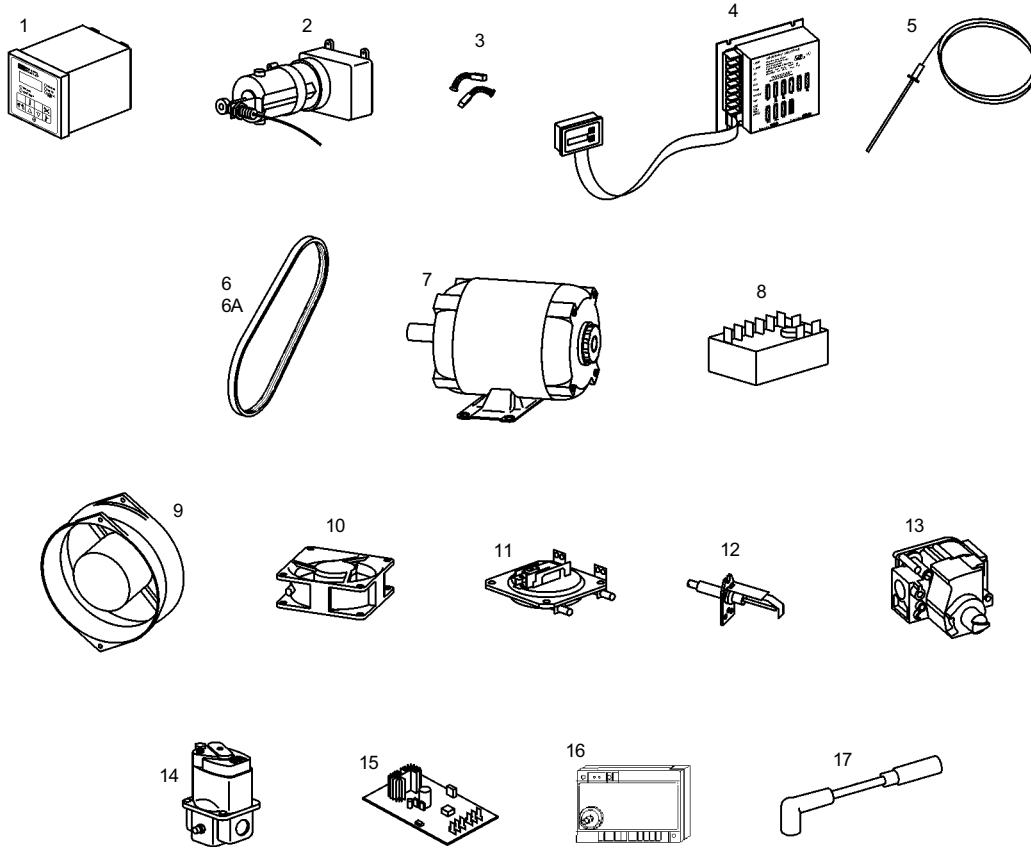

KEY PARTS

ITEM	QTY.	P/N	DESCRIPTION
1	1	47321	DIGITAL TEMPERATURE CONTROLLER
2	1	58390	CONVEYOR DRIVE MOTOR W/MAGNET (2 USED ON SPLIT BELT)
3	1	58484	KIT, 2-BRUSHES AND 2-CAPS
4	1	58323	KIT, CONVEYOR SPEED CONTROLER (37337)
5	2	33984	KIT, THERMOCOUPLE 6" (33812-1)
6A	1	51428	BELT, BLOWER, STANDARD SPEED (1725 RPM) 160J
6B	1	50517	BELT, BLOWER, HIGH RPM (2400) (OPTIONAL) 170J
7	1	44687	MOTOR, BLOWER, 208/230V, 1/2HP
8	1	33983	HIGH LIMIT CONTROL MODULE, 240V
9	1	36451	COOLING FAN (BACKWALL)
10	1	97525	COOLING FAN (CONTROL COMPARTMENT)
11	1	54953	AIR SWITCH
12	1	48455	IGNITOR
13	1	59465	COMBINATION GAS CONTROL VALVE (SAFETY REGULATOR) (52291)
14	1	59450	MODULATING GAS VALVE, M420, 1/2" (41647)
15	1	31651	AMPLIFIER BOARD
16	1	50239	IGNITION MODULE
17	1	50240	IGNITION CABLE, 25"

View of INSTALLATION KIT

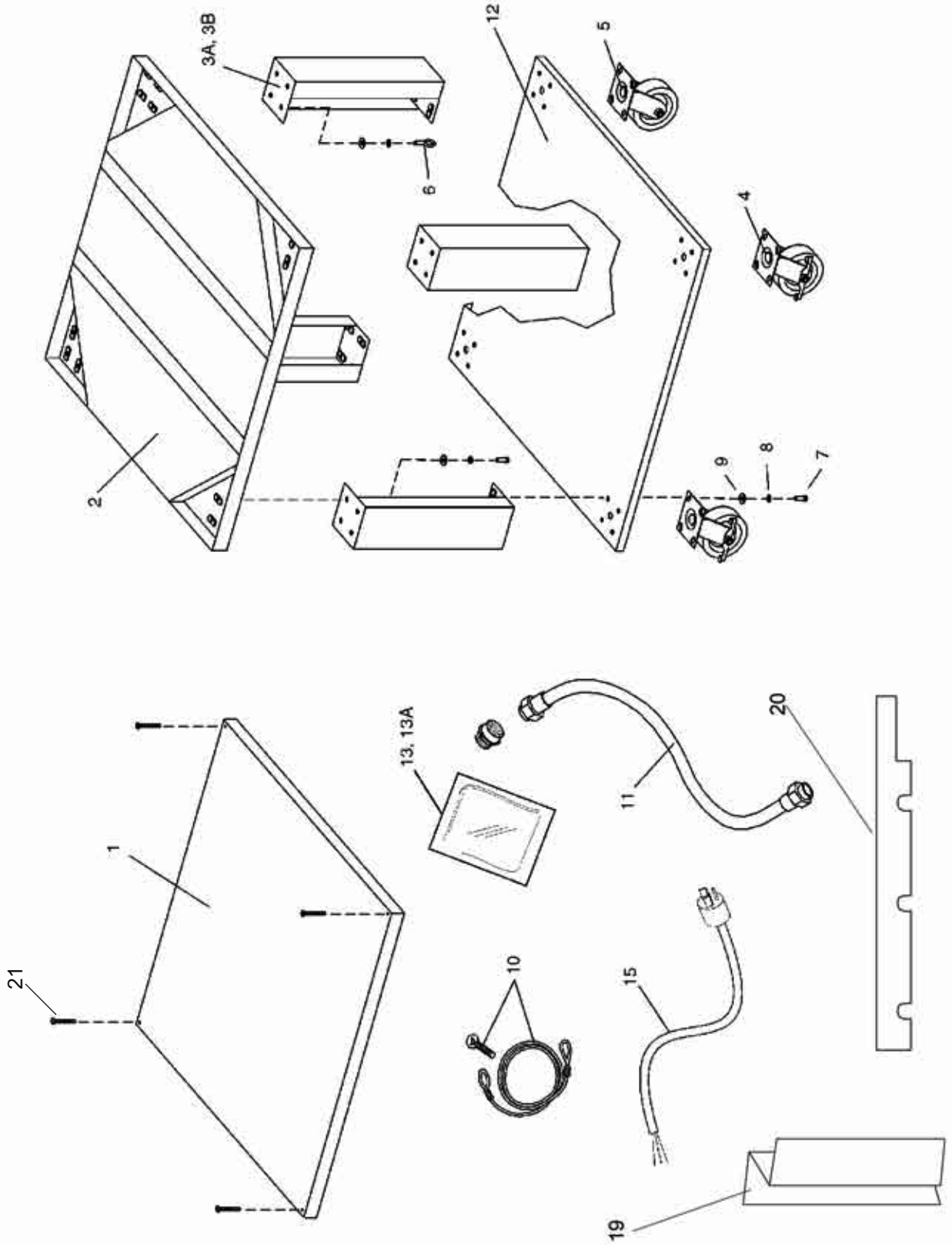

CE-UK	50614	50615	50616
CE	50611	50612	50613
DOMESTIC	50144	50145	50068

Parts for INSTALLATION KIT

ITEM	QTY. SINGLEOVEN	QTY. DOUBLEOVEN	QTY. TRIPLEOVEN	P/N	DESCRIPTION
1	1	1	1	48605	TOP PANEL
2	1	1	1	51977	BASE PAD, W/INSULATION
3A	4	4	--	42890	17-1/2" (445mm) LEG EXTENSION, FOR SINGLE AND DOUBLE OVENS
3B	--	--	4	44799	6" (152mm) LEG EXTENSION, FOR TRIPLE OVENS
3C	4	4	4	22450-0028	LEG-STUD 6" (CE ONLY)
4	2	2	2	22290-0009	CASTER, WITH FLAT PLATE AND BRAKE
5	2	2	2	22290-0010	CASTER, WITH FLAT PLATE (NO BRAKE)
6	1	1	1	21392-0004	EYEBOLT, 3/4"
7	31	31	31	220373	HEX BOLT, 3/8"-16 x 1"
8	32	32	32	21416-0001	FLAT WASHER, 3/8"
9	32	32	32	21422-0001	LOCKWASHER, 3/8"
10	1	1	1	22450-0228	RESTRAINT CABLE ASSEMBLY
11	1	2	3	22361-0001	GAS HOSE, 3/4" X 48" (Not provided to UK -CE)
12	1	1	--	46393	LOWER SHELF - (LIP DOWN POSITION)
13	1	2	3	50276	KIT, LP - (NATURAL GAS TOLP)
13A	1	2	3	50793	KIT, NATURAL GAS - (LP TO NATURAL GAS)
14	1	2	3	M2841	FITTING, PRESSURE TAP (NOT SHOWN)
15	1	2	3	49975	TWIST LOCK PLUG (L6-20P) - WITH 6 FOOT CORD (Included in Country Kit)
15A	1	2	3	49976	CORD 6" NO PLUG- CE (Included in Country Kit)
16	1	1	1	58329	OWNER'S MANUAL
17	1	2	3	23115-0009	MANUAL GAS VALVE (ON/OFF)
18	1	2	3	31823	COUPLING REDUCER 3/4" TO 1/2"
19	-	2	4	58453	PLATE AIR DIVERTER
20	-	1	2	58454	PLATE AIR BLOCK-HEAT GUARD
21	4	4	4	5956	10-32 x 1 1/2" S ^W

VIEW OF STACKING KIT (BG SERIES ON TOP OF OLDER SG SERIES)

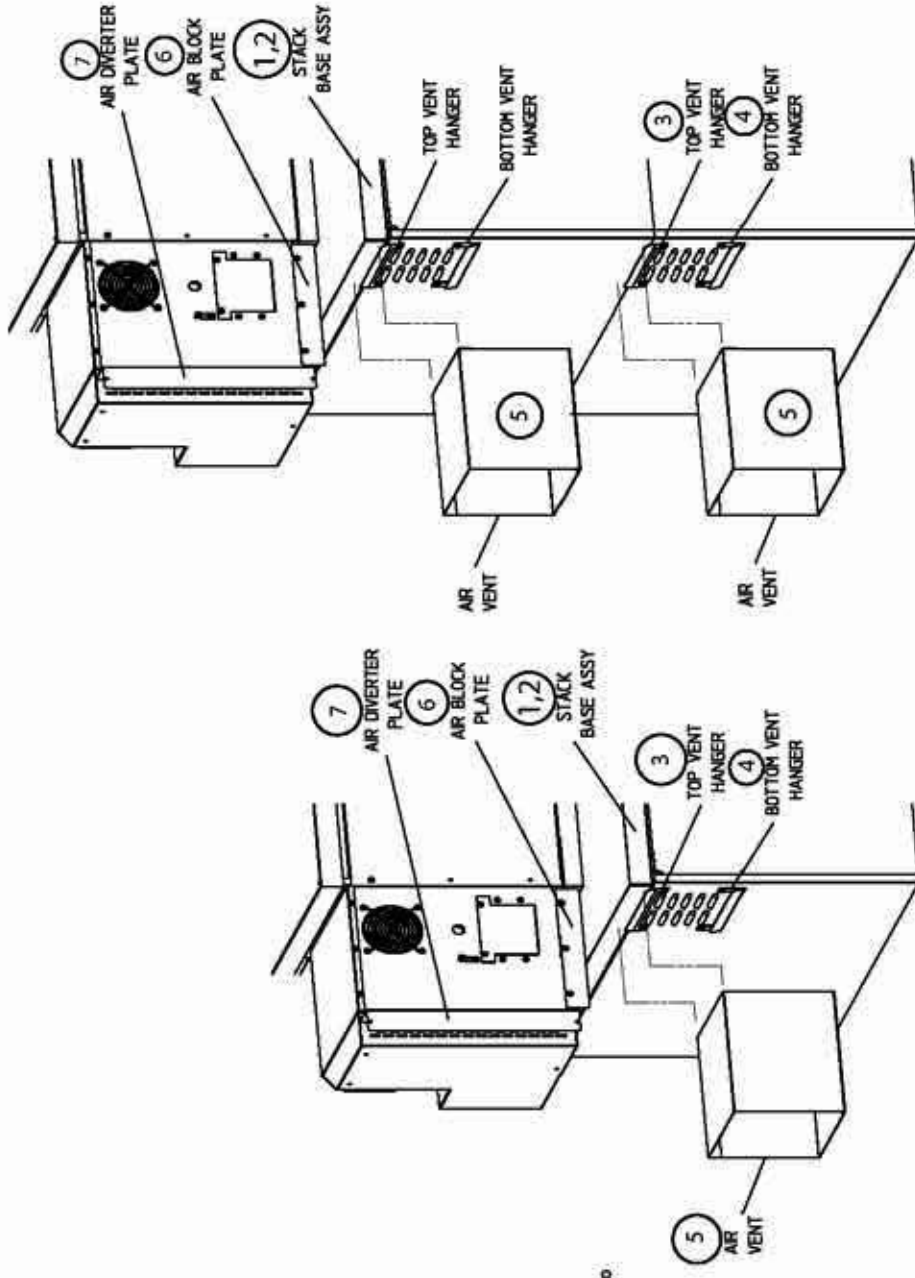

DOUBLE STACK

TRIPLE STACK

BE/BG/SG2138 STACKING KIT

NOTE: USE THESE INSTRUCTIONS FOR THE INSTALLATION OF THE DOUBLE AND TRIPLE STACK UNITS USING BE2136 OR BG2136 ON TOP OF SG2136 OVENS.

DOUBLE OVENS:

1. FASTEN TOP AND BOTTOM VENT HANGERS TO HOLES LOCATED AROUND THE LOUVERS WITH SCREWS THAT ARE PROVIDED.
2. SLIDE AIR VENT ONTO TOP AND BOTTOM VENT HANGERS AND PUSH DOWN UNTIL SECURE.
3. KNOCK OUT HOLES IN TOP COVER OF OVEN.
4. INSERT BASE ASSEMBLY ALIGNMENT PINS INTO MATCHING HOLES OF TOP COVER. (ITEM 9)
5. CAREFULLY LOWER NEW OVEN ONTO BASE ASSEMBLY MAKING SURE THAT BOTTOM OF OVEN FITS OVER BASE ASSEMBLY WALLS.
6. LOOSEN SCREWS FROM CONTROL PANEL AND FASTEN AIR DIVERTER PLATE AND AIR BLOCK PLATE AS SHOWN.

REV	DATE	EGN	REVISION DESCRIPTION	BY	CHK	DATE
B			DESIGN RELEASE FOR PRODUCTION	PC	MSB	07/19/2005

MATERIAL		GAGE:		TOLERANCE UNLESS SPECIFIED	
FINISH		DEC		.0005	
DRAWN		CHECKED		APPROVED	
PC		MSB		07/19/2005	
BLOGGETT				PART NO	
INSTR. STACK KIT BE/BG/SG2138				REV	
ALL DIMENSIONS ARE IN INCHES UNLESS OTHERWISE SPECIFIED. DO NOT SCALE DRAWING.				1 of 1	
58498				B	

Parts for Stacking Kit

Double Kit 58490		Triple Kit 58496		Component	
Item	Qty.	Qty.	Item No.	Item No.	Description
1	1	1	58414		Base Weldment
2	1	1	58492		Insulation For Base
3	1	2	M10551		Top Vent Hanger
4	1	2	M10552		Bottom Vent Hanger
5	1	2	58422		Air Vent Box
6	1	1		Contact Factory	Plate-Air Block (Heat Guard)
7	1	1	58453		Plate-Air Diverter
8	1	1	58498		Instructions
9	4	4	M3828		Alignment Pin

View of PANELS, END PLUGS and WINDOW

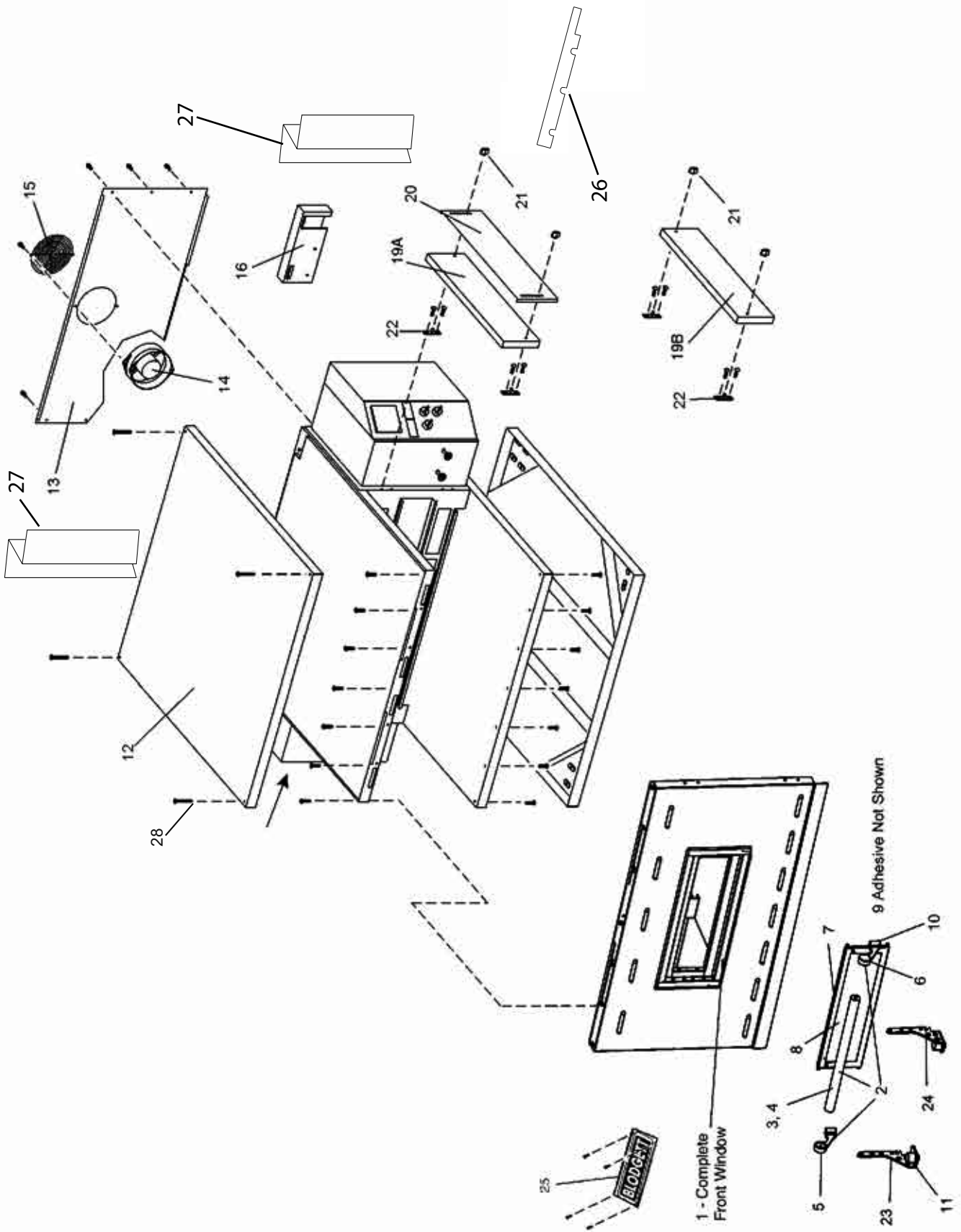

Parts for PANELS, END PLUGS and WINDOW

ITEM QTY.	P/N	DESCRIPTION
1	51054	ASSEMBLY, WINDOW, w/HANDLE, ITEMS 1-10
2	51081	ASSEMBLY, HANDLE, ITEMS 3-6
3	M10092	HANDLE, OUTER
4	M10127	HANDLE, INNER THREADED
5	M1115	HANDLE, BRACKET (LEFT)
6	M1116	HANDLE, BRACKET (RIGHT)
7	51087	FRAME AND WINDOW, ITEMS 8-9
8	M10198	GLASS, 4.1" X 15.150"
9	M1965	ADHESIVE (NOT SHOWN)
10	M1118	SCREW--ATTACHES HANDLE
11	30927	BUMPER
12	48605	TOP PANEL

ITEM QTY.	P/N	DESCRIPTION
13	47633	BACK WALL
14	36451	COOLING FAN- 230VAC
15	31497	FINGER GUARD, COOLING FAN
16	See pp. 1 8 - 21	CHAIN COVER, UPPER
19A	50161	END PLUG, TOP
19B	48622	END PLUG, BOTTOM
20	42771	SLIDE, OUTER SIDE- EYE BROW
21	36452	WING NUT, PLASTIC
22	48640	BRACKET, END PLUG MOUNTING
23	51210	BRACKET, WINDOW HINGE (LEFT)
24	51211	BRACKET, WINDOW HINGE (RIGHT)
25	57399	BLODGETT NAMEPLATE
26	58454	PLATE-AIR BLOCK-HEAT GUARD
27	58453	PLATE-AIR DIVERTER
28	59156	10-32 X 1 1/2" SCREW

View of Right-hand Electrical Compartment

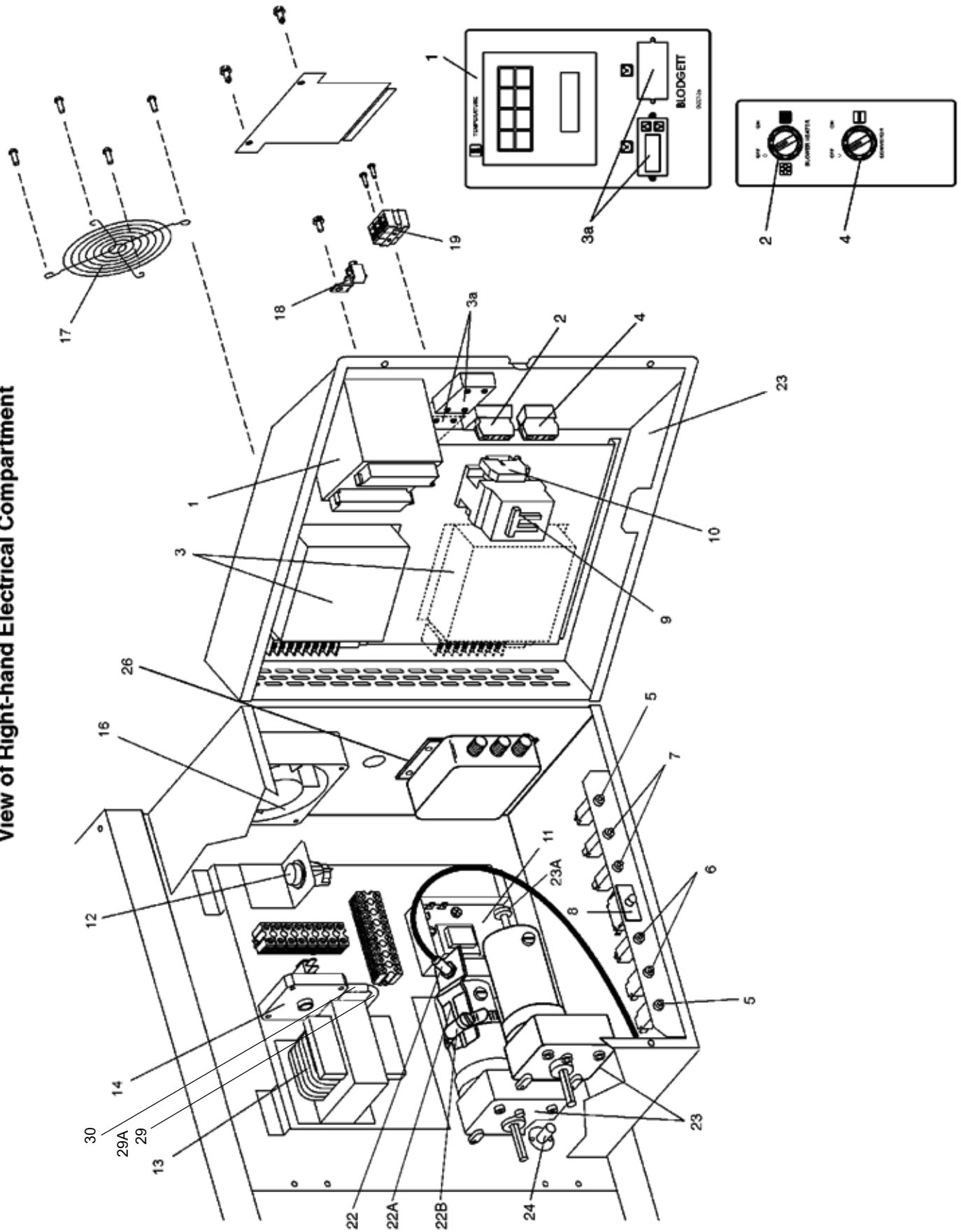

Parts for Right-hand Electrical Compartment

ITEM	QTY. SINGLE BELT	QTY. SPLIT BELT	P/N	DESCRIPTION
1	1	1	47321	DIGITAL TEMPERATURE CONTROLLER
2	1	1	46522	KIT, BLOWER/HEAT SELECTOR SWITCH/W/KNOB AND 2 CONTACT BLOCKS
3	1	2	58323	KIT, CONVEYOR SPEED CONTROLLER WITH DIGITAL DISPLAY (INC. ITEM 3A) (37337)
3A	1	2	37503	DIGITAL DISPLAY ONLY
4	1	1	46521	KIT, CONVEYOR SELECTOR SWITCH WITH KNOB AND CONTACT BLOCK
5	1	2	48635	CIRCUIT BREAKER, 0.3A (DRIVE MOTORS)
6	2	2	46831	CIRCUIT BREAKER, 8A (BLOWER MOTORS)
7	2	2	45036	CIRCUIT BREAKER, 3A (CONTROL CIRCUIT)
8	1	1	28021-0047	SAFETY SWITCH
9	1	1	28041-0011	CONTACTOR
10	2	2	33363	END STOP, CONTACTOR
11	1	1	33983	HIGH LIMIT CONTROL MODULE, 240V
12	1	1	35145	RESET SWITCH, HIGH LIMIT
13	1	1	31504	TRANSFORMER, 230V PRI : 120V SEC, 200VA
14	1	1	54953	AIR SWITCH - NEGATIVE PRESSURE

ITEM	QTY. SINGLE BELT	QTY. SPLIT BELT	P/N	DESCRIPTION
16	1	1	97525	COOLING FAN, 230V
17	1	1	27470-0004	FINGER GUARD, COOLING FAN
18	1	1	F716A8701	GROUND LUG
19	1	1	44390	TERMINAL BLOCK, 3-POLE
22	1	2	22450-0249	SENSOR PICKUP
22A	1	2	22450-0248	BRACKET-PICKUP SENSOR
22B	1	2	220416	CLAMP-SECURES BRACKET
23	1	2	58390	MOTOR, CONVEYOR DRIVE WITH 2-POLE MAGNET
23A	1	2	39002	MAGNET 2-POLE
23B	1	2	310-0017	ADHESIVE
23D	1	2	58484	KIT, 2 BRUSHES & 2 CAPS
24	1	1	33984	KIT, THERMOCOUPLE (33812-1)
26	1	1	33813	RF FILTER
27	2	2	58453	PLATE- AIR DIVERTER
28	1	1	58454	PLATE- AIR BLOCK -HEAT GUARD
29	1	1	50003	ALUMINIUM AIR TUBE 9 1/2"
29A	1	1	15125-0002	ALUMINIUM AIR TUBE (Sold 12" sections)
30	1	1	22450-0297	SILICONE TUBE (Sold 12" sections)

View of Left-hand Electrical and Gas Train Compartment

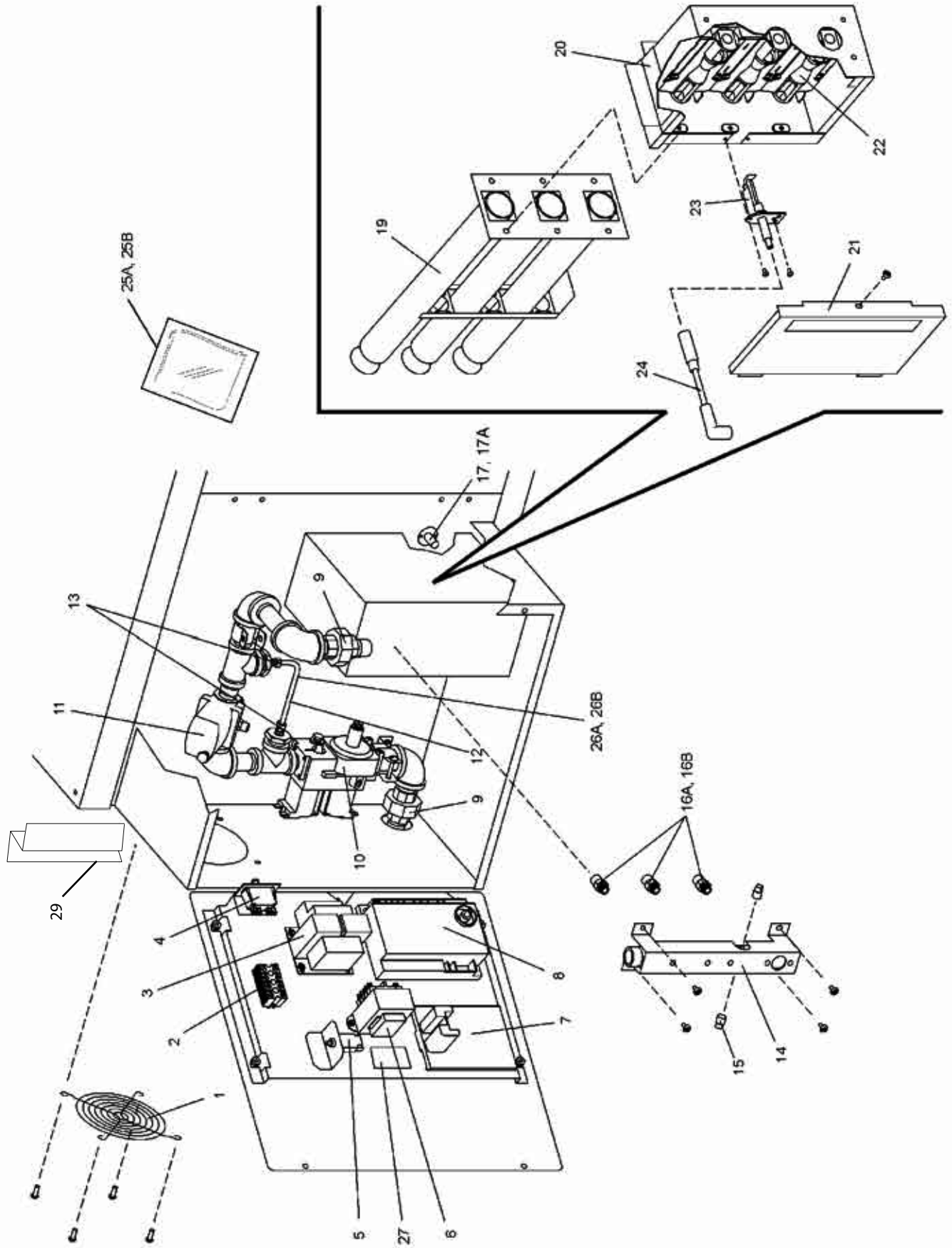

Parts for Left-hand Electrical and Gas Train Compartment

ITEM QTY.	P/N	DESCRIPTION
1 1	27470-0004	FANGUARD <i>NOTE: The oven does NOT have a cooling fan in this location. The opening provides passive cooling only.</i>
2 1	44390	TERMINAL BLOCK, 3-POLE
3 1	32108	TRANSFORMER, 240V PRI : 24V SEC, 65VA
4 1	28021-0047	SAFETY SWITCH
5 1	45644	CIRCUIT BREAKER, 1A
6 1	41872	TRANSFORMER, 240V PRI : 24V SEC, 25VA
7 1	31651	AMPLIFIER BOARD
8 1	50239	IGNITIONMODULE-24VAC
9 2	23051-0003	UNION, 1/2" PIPE
10 1	59465	COMBINATION GAS CONTROL VALVE (SAFETY REGULATOR)(52291)*-NAT GAS
10A 1	50726	KIT- CONVERT MAIN GAS VALVE FROM LP TO NATURAL GAS
10B 1	59415	KIT- CONVERT MAIN GAS VALVE FROM NATURAL GAS TO LP
11 1	59450	MODULATING GAS VALVE, M420, 1/2" (41647)
12 AIR	48740	TUBE, ALUMINUM, 1/4" (6.35mm) O.D. -BYPASS
13 2	44888	COMPRESSION FITTING, 1/4" TUBE
14 1	49940	MANIFOLD
15 2	30002	TAP PLUG

ITEM QTY.	P/N	DESCRIPTION
16A 3	44984	ORIFICE, MAIN, NATURAL GAS 0.0935" (2.3749mm, #42 DRILL)
16B 3	47320	ORIFICE, MAIN, PROPANE 0.0595" (1.5113mm, #54 DRILL)
17 1	33984	KIT, THERMOCOUPLE (33812-1)
19 1	48489	ASSEMBLY, BURNER TUBES
20 1	49955	HOUSING, INSHOT BURNERS
21 1	47654	COVER PLATE, INSHOT BURNER HOUSING
22 3	44983	BURNER, INSHOT
23 1	48455	IGNITOR
24 1	50240	IGNITION CABLE, 25" (635mm)
25A 1	50276	KIT- NAT GAS TO LP (INCLUDES ITEMS 10B, 16B, 26B & 28B)
25B 1	50793	KIT- LP TO NAT GAS (INCLUDES ITEMS 10A, 16A, 26A & 28A)
26A 1	58954	ORIFICE, BYPASS, NATURAL GAS 0.086" (2.0574mm, #44 DRILL)
26B 1	49948	ORIFICE, BYPASS, PROPANE 0.0520" (1.3208mm, #55 DRILL)
27 1	50794	IGNITION RELAY
28A 1	50796	INSTRUCTIONS TO CONVERT- LP TO NAT
28B 1	50155	INSTRUCTIONS TO CONVERT- NAT TO LP
29 2	58453	PLATE- AIR DIVERTER

View of Rear Compartment and Blowers

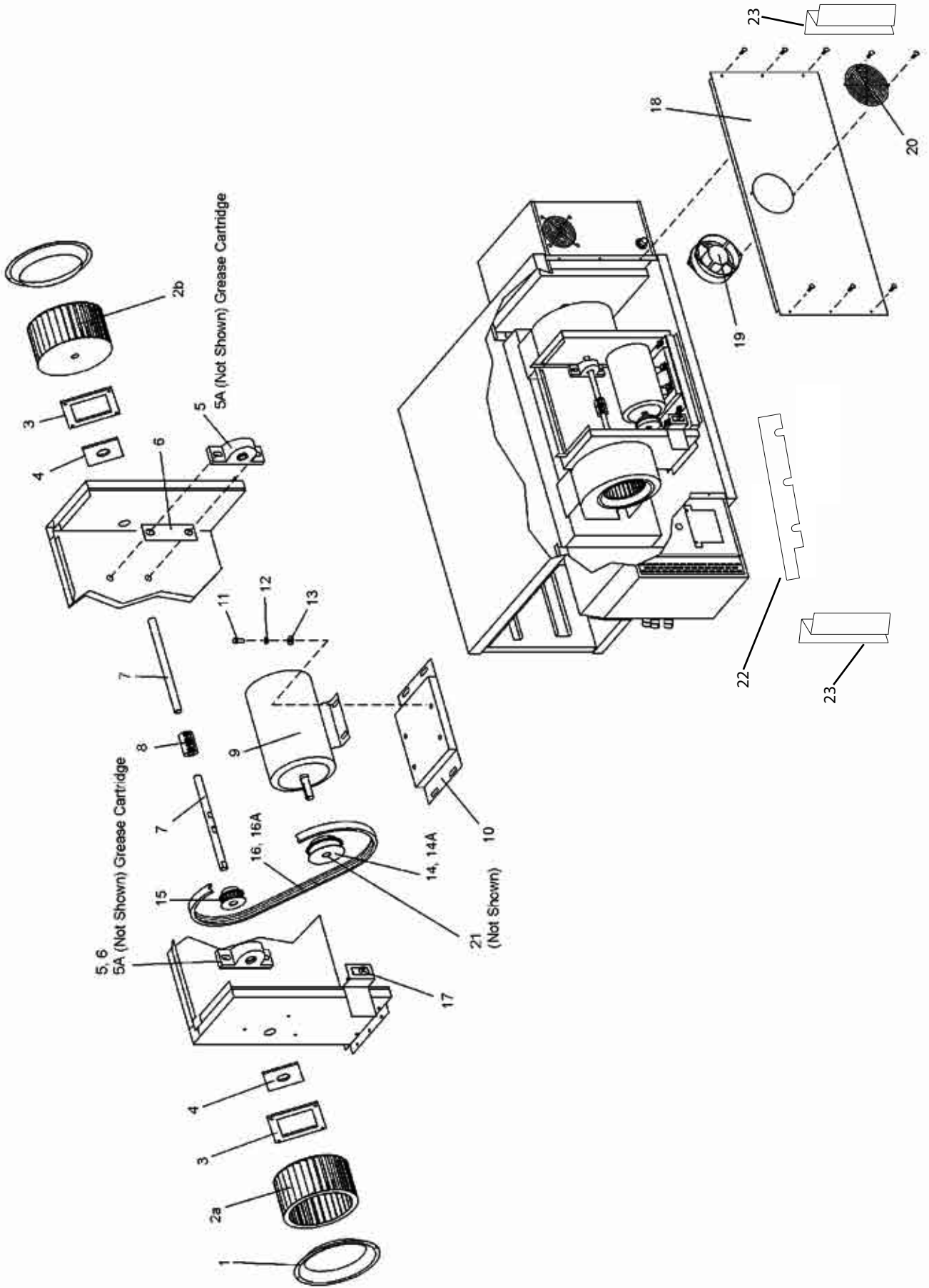

Parts for Rear Compartment and Blowers

ITEM QTY.	P/N	DESCRIPTION
1 2	42951	INLET RING
2a 1	42752	BLOWER WHEEL (VIEWED FROM REAR OF OVEN-LEFTHAND)
2b 1	42753	BLOWER WHEEL (VIEWED FROM REAR OF OVEN-RIGHTHAND)
3 2	42999	RETAINER, TEFLON SEAL
4 2	35121-0045	TEFLON SEAL
5 2	22072-0025	BEARING, 5/8" BORE WITH STANDARD GREASE
5A --	17110-0015	GREASE, STANDARD CARTRIDGE
6 2	50160	SHIM, BEARING
7 2	50151	BLOWER SHAFT
8 1	44748	COUPLING, BLOWER SHAFT
9 1	44687	MOTOR, BLOWER, 208/230V, 1/2HP
10 1	44688	PLATE, MOTOR MOUNTING
11 4	A3896	SCREW, HEX CAP HEAD 5/16"-18 X 7/8"

ITEM QTY.	P/N	DESCRIPTION
12 4	B301A8847	FLAT WASHER, 5/16"
13 4	A3682	LOCK WASHER, 5/16"
14A 1	50224*	PULLEY-MOTOR (STANDARD 1725 RPM) 1.80" DIA.
14B 1	50260*	PULLEY-MOTOR(HIGH SPEED 2400 RPM) 2.487" DIA.
15 1	50224*	PULLEY, BLOWER SHAFT 1.80" DIA.
16A 1	51428*	BELT (STANDARD 1725 RPM) 160 J
16B 1	50517*	BELT, (50/60Hz) (HIGH SPEED 2400 RPM) 170 J
17 1	28021-0061	SAFETY SWITCH
18 1	47633	BACKWALL
19 1	36451	COOLING FAN-230V
20 1	31497	FINGER GUARD, COOLING FAN
21 1	50259*	BUSHING (HIGH SPEED 2400 RPM)-SPLIT TAPER
22 1	58454	PLATE-AIR BLOCK (HEAT GUARD)
23 2	58453	PLATE-AIR DIVERTER

		ITEM 14		ITEM 15		ITEM 16			
RPM	RPM KIT P/N	HERTZ	MOTOR PULLEY W/SPLIT BUSHING	MTR PULLEY P/N	BLWR SHAFT PULLEY DESCRIPTION	BLWR SHAFT PULLEY	BELT SIZE DESCRIPTION	BELT P/N	RPM OF FAN
HIGH SPEED	50256	60	POLY G BUSHING	50260	POLY V	50224	POLY V	50517	2400
STD SPEED	51427	50	POLY V	50259	POLY V	50224	POLY V	51428	1950
		60		50224					1725

View of Single-Belt Conveyor - Standard Speed (3-30 Minutes), High Speed (1-10 minutes)

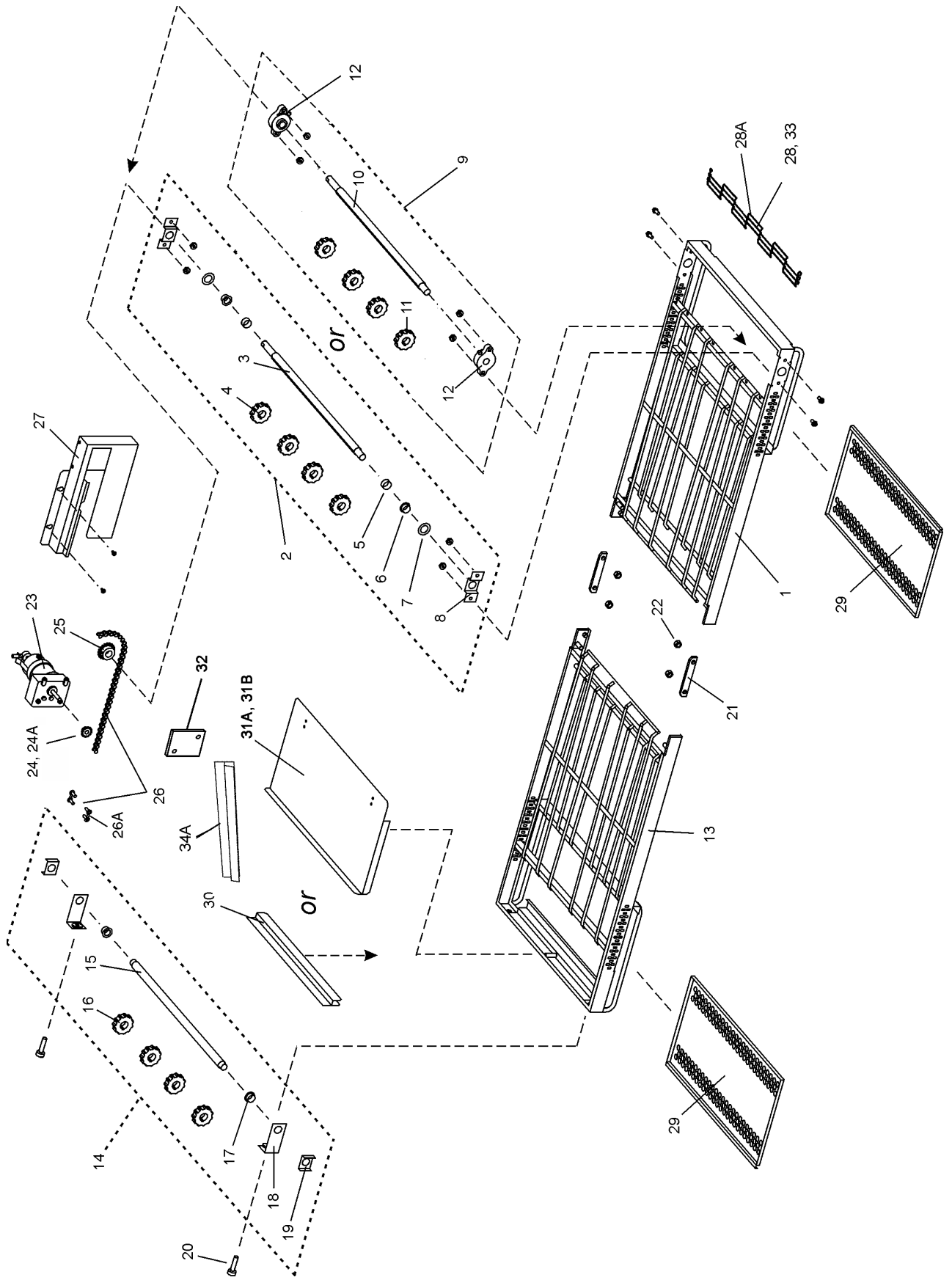

Parts for Single-Belt Conveyor - Standard Speed (3-30 Minutes), High Speed (1-10 minutes)

ITEM QTY.	P/N - 60"		P/N - 76"		DESCRIPTION
	CONVEYOR	CONVEYOR	CONVEYOR	CONVEYOR	
1	48847	< - - - -	48797	- - - - ->	FRAME, DRIVESIDE
2	1	< - - - -	48781	- - - - ->	ASSEMBLY, STANDARD DRIVE SHAFT (INC. ITEMS 3-8)
3	1	< - - - -	48781	- - - - ->	DRIVE SHAFT
4	4	< - - - -	22229-0003	- - - - ->	SPROCKET, CONV. BELT
5	2	< - - - -	43275	- - - - ->	SPACER
6	2	< - - - -	22034-0003	- - - - ->	BUSHING, BRONZE 5/8" I.D.
7	2	< - - - -	35000-1080	- - - - ->	SPACER, NYLON
8	2	< - - - -	49972	- - - - ->	BRACKET, DRIVESUPPORT
9	1	< - - - -	48782	- - - - ->	ASSEMBLY, HIGH SPEED DRIVE SHAFT (INC. ITEMS 10-11)
10	1	< - - - -	48781	- - - - ->	DRIVE SHAFT
11	4	< - - - -	22229-0003	- - - - ->	SPROCKET, CONV. BELT
12	2	< - - - -	45377	- - - - ->	FLANGE BEARING (HIGH SPEED ONLY)
13	1	48746	48795	48795	FRAME, IDLER SIDE
14	1	48780	48780	48780	ASSEMBLY, IDLER SHAFT (INC. ITEMS 15-19)
15	1	< - - - -	48779	- - - - ->	IDLER SHAFT
16	4	< - - - -	22229-0003	- - - - ->	SPROCKET, CONV. BELT
17	2	< - - - -	22034-0003	- - - - ->	BUSHING, BRONZE 5/8" I.D.
18	2	37000-0413	37000-0413	37000-0413	BRACKET, IDLER ADJUSTMT.
19	2	< - - - -	54947	- - - - ->	BRACKET, IDLER SUPPORT
20	2	35000-1008	35000-1008	35000-1008	SCREW, IDLER ADJUSTMENT
21	2	< - - - -	50792	- - - - ->	PIVOT PLATE
22	4	< - - - -	21176-0002	- - - - ->	LOCKNUT, HEX 3/8"-16 SS
23	1	< - - - -	SEE PAGES 12 & 13	SEE PAGES 12 & 13	ASSEMBLY, CONVEYOR MOTOR AND PICKUP (INC. ITEM 23a)
23A	1	< - - - -	SEE PAGES 12 & 13	SEE PAGES 12 & 13	PICKUP
24	1	< - - - -	34128	- - - - ->	SPROCKET, CONVEYOR DRIVE MOTOR, 20T (STANDARD SPEED) .317 BORE
24A	1	< - - - -	38215	- - - - ->	SPROCKET, 22T (HIGH SPEED) .314 BORE
25	1	< - - - -	22159-0003	- - - - ->	SPROCKET, SHAFT DRIVE SHAFT, 20T 5/8 BORE
26	1	50050	50052	50052	ASSEMBLY, DRIVE CHAIN (INC. ITEM 26a)
26A	1	< - - - -	3101212	- - - - ->	MASTER LINK, DRIVE CHAIN
27	1	48851	50029	50029	ASSEMBLY, CHAIN COVER FOR OVENS WITH RIGHT-SIDE CONTROLS
28	1	50057	50059	50059	BELT, CONVEYOR, 18"/457mm, STANDARD
28A	A/R	< - - - -	8500236	- - - - ->	12" SECTION OF BELT
29	2	48707	48708	48708	CRUMB PAN W/HOLES, ENTRANCE & EXIT
30	1	50044	50044	50044	END STOP
31A	1	50040	50040	50040	EXIT TRAY, 8"/203mm
31B	1	50023	50023	50023	EXIT TRAY, 20"/508mm
32	1	50235	50235	50235	PLATE MOTOR COVER ASSY
33	1	58391	58391	58391	KIT, MASTER LINK
34A	1	30830	30830	30830	SIDE STOP, LEFT

View of Split Belt Conveyor - Standard Speed (3-30 Minutes), High Speed (1-10 minutes)

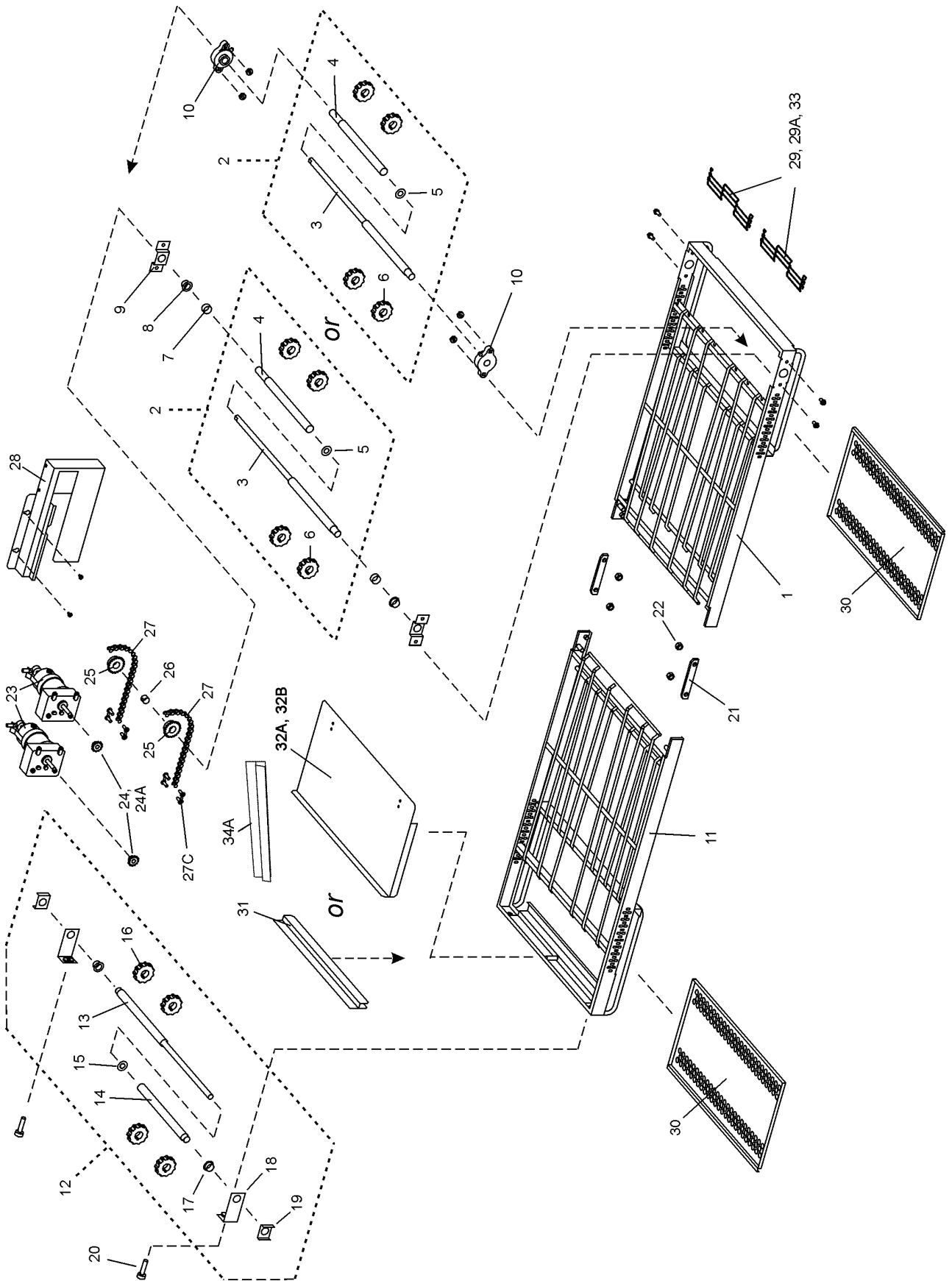

Parts for Split Belt Conveyor - Standard Speed (3-30 Minutes), High Speed (1-10 minutes)

ITEM QTY.	P/N - 60" CONVEYOR	P/N - 76" CONVEYOR	DESCRIPTION
1	48847	48790	FRAME, DRIVESIDE
2	< - - - - -	48759	ASSEMBLY, SPLIT DRIVE SHAFT, STANDARD AND HIGH SPEED (INC. ITEMS 3-6)
3	< - - - - -	49969	SPLIT DRIVE SHAFT - MAIN 22.07"
4	< - - - - -	48837	SPLIT DRIVE SHAFT - SLEEVE 11.22"
5	< - - - - -	21415-0001	FLAT WASHER, BRONZE
6	< - - - - -	22229-0003	SPROCKET, CONV. BELT
7	< - - - - -	43275	SPACER (STANDARD SPEED ONLY)
8	< - - - - -	22034-0003	BUSHING, BRONZE 5/8" I.D. (STANDARD ONLY)
9	< - - - - -	49972	BRACKET, DRIVE SUPPORT (STANDARD ONLY)
10	< - - - - -	45377	FLANGE BEARING (HIGH SPEED ONLY)
11	48746	48795	FRAME, IDLERSIDE
12	< - - - - -	48769	ASSEMBLY, SPLIT IDLER SHAFT (INC. ITEMS 13-19)
13	< - - - - -	49968	SPLIT IDLER SHAFT - MAIN 20.12"
14	< - - - - -	48778	SPLIT IDLER SHAFT - SLEEVE 9.94"
15	< - - - - -	21415-0001	FLAT WASHER, BRONZE
16	< - - - - -	22229-0003	SPROCKET, CONV. BELT
17	< - - - - -	22034-0003	BUSHING, BRONZE 5/8" I.D.
18	< - - - - -	37000-0413	BRACKET, IDLER ADJUSTMT.
19	< - - - - -	54947	BRACKET, IDLER SUPPORT
20	< - - - - -	35000-1008	SCREW, IDLER ADJUSTMENT
21	< - - - - -	50792	PIVOT PLATE
22	< - - - - -	21176-0002	LOCK NUT, HEX 3/8" - 16SS
23	SEE PAGES 12 & 13		
			ASSEMBLY, CONVEYOR MOTOR AND PICKUP (INC. ITEM 23a)

ITEM QTY.	P/N - 60" CONVEYOR	P/N - 76" CONVEYOR	DESCRIPTION
23A	1	SEE PAGES 12 & 13	PICKUP
24	2	< - - - - - 34128	SPROCKET, CONVEYOR DRIVE MOTOR, 20T (STANDARD SPEED) .317 BORE
24A	2	< - - - - - 38215	SPROCKET, 22T (HIGH SPEED) .314 BORE
25	2	< - - - - - 22159-0003	SPROCKET, CONVEYOR DRIVE SHAFT, 20T (STANDARD AND HIGH SPEED)
26	1	< - - - - - 35900-0023	BUSHING, DRIVES PROCKET
27A	1	50050	ASSEMBLY, DRIVE CHAIN, REAR BELT (LONG - INC. ITEM 27C) 20"
27B	1	50051	ASSEMBLY, DRIVE CHAIN, FRONT BELT (SHORT - INC. ITEM 27C) 12"
27C	2	< - - - - - 3101212	MASTER LINK, DRIVE CHAIN
28	1	48851	ASSEMBLY, CHAIN COVER
29	2	50056	BELT, CONVEYOR, 9"/229mm, STANDARD
29A	A/R	< - - - - - 37022	12" SECTION OF BELT
30	2	48707	CRUMB PAN, W/HOLES, ENTRANCE & EXIT
31	1	50044	END STOP
32A	1	50040	EXIT TRAY, 8"/203mm
32B	1	50023	EXIT TRAY, 20"/508mm
33	1	< - - - - - 37020	KIT, MASTER LINK
34A	1	30830	SIDESTOP, LEFT

BG2136

Standard Air finger configuration

NOTE: Left-to-Right configuration is shown.

For Right-to-Left conveyors, "mirror" the placement of the fingers.



REV	DATE	ECN	REVISION DESCRIPTION	BY	CHK	DATE
B	08/23/2004	004295	RELEASED FOR PRODUCTION	KMH	NSS	08/26/2004
C	08/02/2006	006234	UPDATED DRAWING TO VENDOR'S SPECS. UPDATED AMPLIFIER TEXT	FC	NSS	08/03/2006

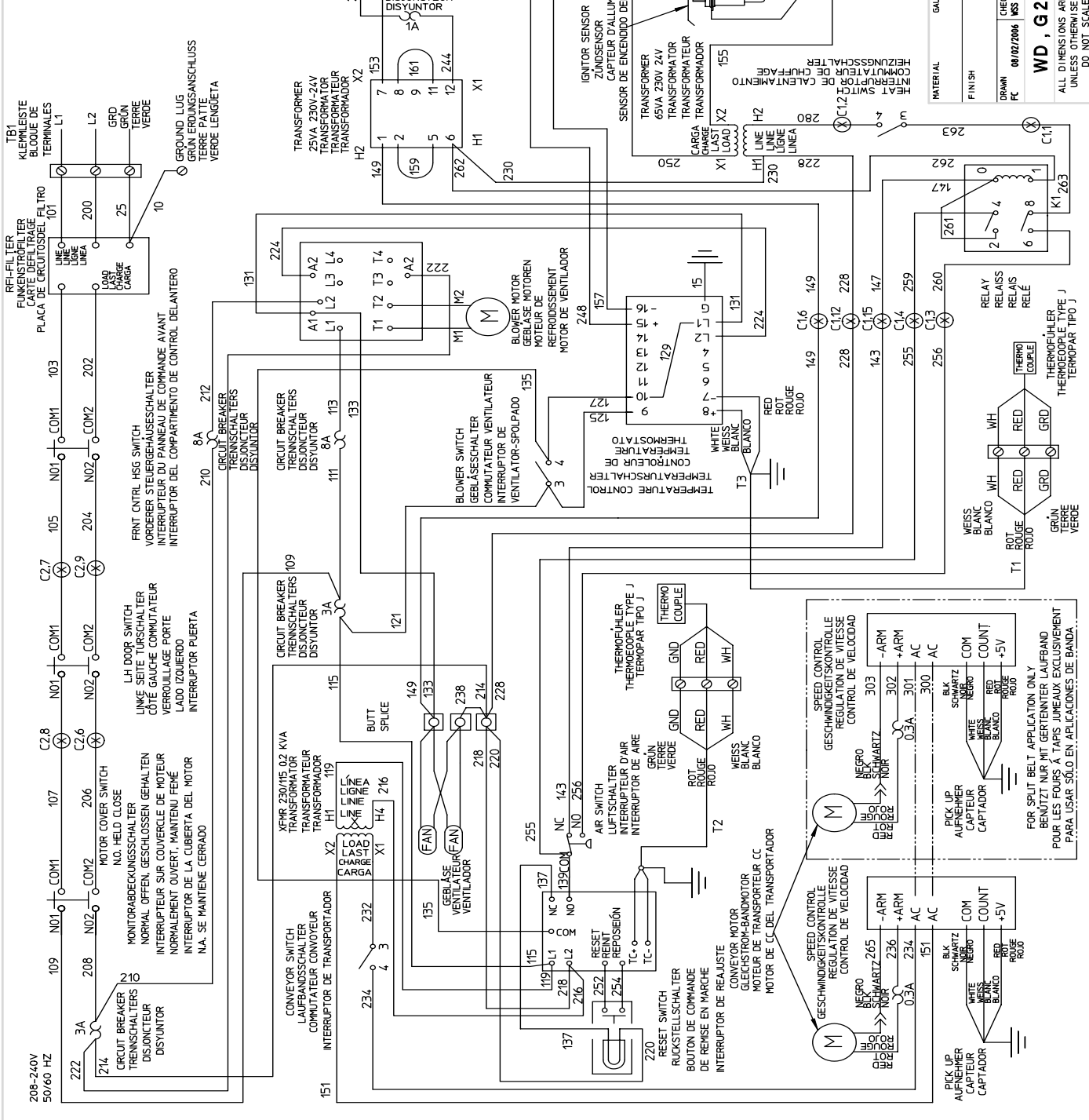

NOTE: ALL WIRES ARE TO BE #18 AWG UNLESS OTHERWISE SPECIFIED.
 C1 = 6 CIRCUIT AMP UML CONNECTOR.
 C2 = 12 CIRCUIT AMP UML CONNECTOR.
 □ = IN LINE BUTT SPLICE.

ENG/GM/FR/SP
 SEE WD 55551 FOR IT/GR/DN/DU

BLOGGETT

TOLERANCE UNLESS SPECIFIED	APPROVED	DATE
ANGLES X 45°	08/03/2006	08/03/2006
DEC XX ± 0.05		
XX ± 0.05		
XX ± 0.05		
XX ± 0.05		
XX ± 0.05		
XX ± 0.05		
XX ± 0.05		

WD, G208-240V 50/60HZ G0BG2136
 ALL DIMENSIONS ARE IN INCHES UNLESS OTHERWISE SPECIFIED.
 DO NOT SCALE DRAWING.

PART NO 55553
 SH 1 OF 1
 REV C

