

**BLOOMFIELD INDUSTRIES**

2 ERIK CIRCLE, P. O. Box 280  
Verdi, NV 89439  
telephone: 775-689-5700  
fax: 888-492-2783  
[www.wellsbloomfield.com](http://www.wellsbloomfield.com)



*Model 8372 Brewer  
with optional  
8900-Series  
Glass Decanter*

OWNERS MANUAL  
for  
**Aquarius** ™

**BOTTLED WATER  
DECANTER  
COFFEE BREWERS**

**MODEL  
8372**

for  
**3 Gallon  
and  
5 Gallon  
Plastic Bottles**

**Includes:  
Installation  
Operation  
Use & Care  
Servicing Instructions**

PRINTED IN UNITED STATES OF AMERICA

## WARRANTY STATEMENT

All electrical equipment manufactured by BLOOMFIELD INDUSTRIES is warranted against defects in materials and workmanship for a period of one year from the date of original installation or eighteen (18) months from the date of shipment from our factory, whichever comes first, and is for the benefit of the original purchaser, except that:

- a. airpots carry a 30 day parts warranty only.
- b. dispensers; i.e., tea and coffee carry a 90 days parts warranty only, excludes decanters.

THE FOREGOING OBLIGATION IS EXPRESSLY GIVEN IN LIEU OF ANY OTHER WARRANTIES, EXPRESSED OR IMPLIED, INCLUDING ANY IMPLIED WARRANTY OF MERCHANTABILITY OR FITNESS FOR A PARTICULAR PURPOSE, WHICH ARE HEREBY EXCLUDED.

BLOOMFIELD INDUSTRIES DIVISION / SPECIALTY EQUIPMENT MANUFACTURING CORPORATION SHALL NOT BE LIABLE FOR INDIRECT, INCIDENTAL OR CONSEQUENTIAL DAMAGES OR LOSSES FROM ANY CAUSE WHATSOEVER.

This warranty is void if it is determined that upon inspection by an Authorized Service Agency that the equipment has been modified, misused, misapplied, improperly installed, or damaged in transit or by fire, flood or act of God.

It also does not apply if the serial nameplate has been removed or unauthorized service personnel perform service. The prices charged by Bloomfield Industries for its products are based upon the limitations in this warranty. Seller's obligation under this warranty is limited to the repair of defects without charge by a Bloomfield Industries Authorized Service Agency or one of its sub-agencies. This service will be provided on customer's premises for non-portable models. Portable models (a device with a cord and plug) must be taken or shipped to the closest Authorized Service Agency, transportation charges prepaid, for services.

In addition to restrictions contained in this warranty, specific limitations are shown below (Additional Warranty Exclusions). Bloomfield Industries Authorized Service Agencies are located in principal cities.

This warranty is valid in the United States and void elsewhere. Please consult your classified telephone directory or your food service equipment dealer; or, for information and other details concerning warranty, write to:

**Service Parts Department  
Bloomfield Industries  
P.O. Box 280  
Verdi, NV 89439**

**Phone: (775) 689-5700**

**Fax: (888) 492-2783**

## SERVICE POLICY AND PROCEDURE GUIDE ADDITIONAL WARRANTY EXCLUSIONS

1. Resetting of safety thermostats, circuit breakers, overload protectors, or fuse replacements unless warranted conditions are the cause.
2. All problems due to operation at voltages other than specified on equipment nameplates—conversion to correct voltage must be the customer's responsibility.
3. All problems due to electrical connections not made in accordance with electrical code requirements and wiring diagrams supplied with the equipment.
4. Replacement of items subject to normal wear, to include such items as knobs and light bulbs. Normal maintenance functions including adjustment of thermostats, microswitches, and replacement of fuses and indicating lights are not covered under warranty.
5. All problems due to inadequate water supply, such as fluctuating, or high or low water pressure.
6. All problems due to mineral/calcium deposits, or contamination from chlorides/chlorines. De-liming is considered a preventative maintenance function and is not covered by warranty.
7. Full use, care and maintenance instructions are supplied with each machine. Those miscellaneous adjustments noted are customer responsibility. Proper attention will prolong the life of the machine.
8. Travel mileage is limited to sixty (60) miles from an authorized Service Agency or one of its sub-agencies.
9. All labor shall be performed during normal working hours. Overtime premium shall be charged to the customer.
10. All genuine Bloomfield replacement parts are warranted for ninety (90) days from date of purchase on non-warranted equipment. **Any use of non-genuine Bloomfield parts completely voids any warranty.**
11. Installation, labor and job check-out are not considered warranty.
12. Charges incurred by delays, waiting time or operating restrictions that hinder the service technicians ability to perform services are not covered by warranty. This includes institutional and correctional facilities.

## SHIPPING DAMAGE CLAIMS PROCEDURE

**NOTE:** For your protection, please note that equipment in this shipment was carefully inspected and packaged by skilled personnel before leaving the factory. Upon acceptance of this shipment, the transportation company assumes full responsibility for its safe delivery.

**IF SHIPMENT ARRIVES DAMAGED:**

1. **VISIBLE LOSS OR DAMAGE:** Be certain that any visible loss or damage is noted on the freight bill or express receipt, and that the note of loss or damage is signed by the delivery person.
2. **FILE CLAIM FOR DAMAGE IMMEDIATELY:** Regardless of the extent of the damage.

3. **CONCEALED LOSS OR DAMAGE:** if damage is unnoticed until the merchandise is unpacked, notify the transportation company or carrier immediately, and file "CONCEALED DAMAGE" claim with them. This must be done within fifteen (15) days from the date the delivery was made to you. Be sure to retain the container for inspection.

Bloomfield Industries cannot assume liability for damage or loss incurred in transit. We will, however, at your request, supply you with the necessary documents to support your claim.

## TABLE OF CONTENTS

WARRANTY STATEMENT	xi
SPECIFICATIONS	1
FEATURES & OPERATING CONTROLS	2
PRECAUTIONS & GENERAL INFORMATION	3
AGENCY APPROVAL INFORMATION	3
INSTALLATION	4
OPERATION	5
CLEANING INSTRUCTIONS	8
TROUBLESHOOTING SUGGESTIONS	10
SERVICING INSTRUCTIONS	11
Delime Water Tank	14
EXPLODED VIEWS & PARTS LISTS	16
WIRING DIAGRAM	19

Thank You for purchasing this Bloomfield Industries appliance.

Proper installation, professional operation and consistent maintenance of this appliance will ensure that it gives you the very best performance and a long, economical service life.

This manual contains the information needed to properly install this appliance, and to use, care for and maintain or repair the appliance in a manner which will ensure its optimum performance.

## SPECIFICATIONS

MODEL	STYLE	VOLTS	WATTS	AMPS 1 $\phi$	POWER SUPPLY CORD
8372 8372OR	3 WARMER STEP-UP DECANTER BREWER	120 VAC	1800 W	15 A	NEMA 5-15P
8372CA *	with FAUCET	120 VAC	1500 W	12.5 A	NEMA 5-15P

\* meets Canadian standards

# FEATURES AND OPERATING CONTROLS

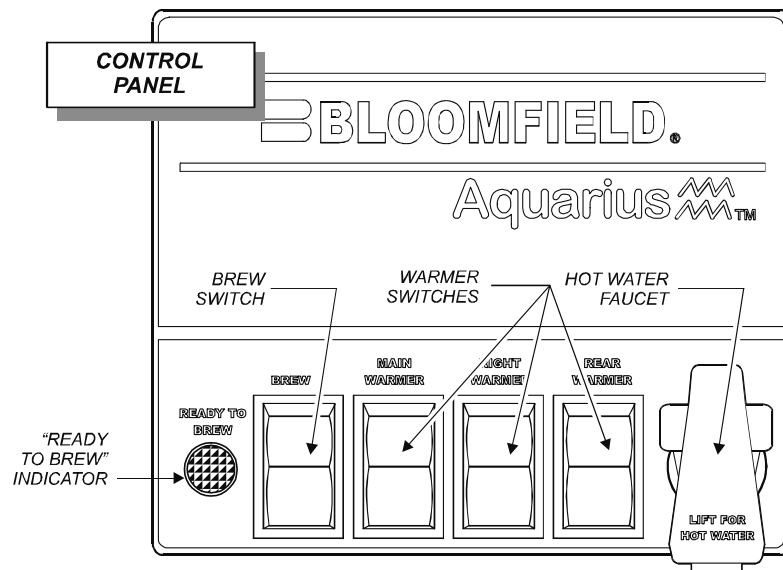
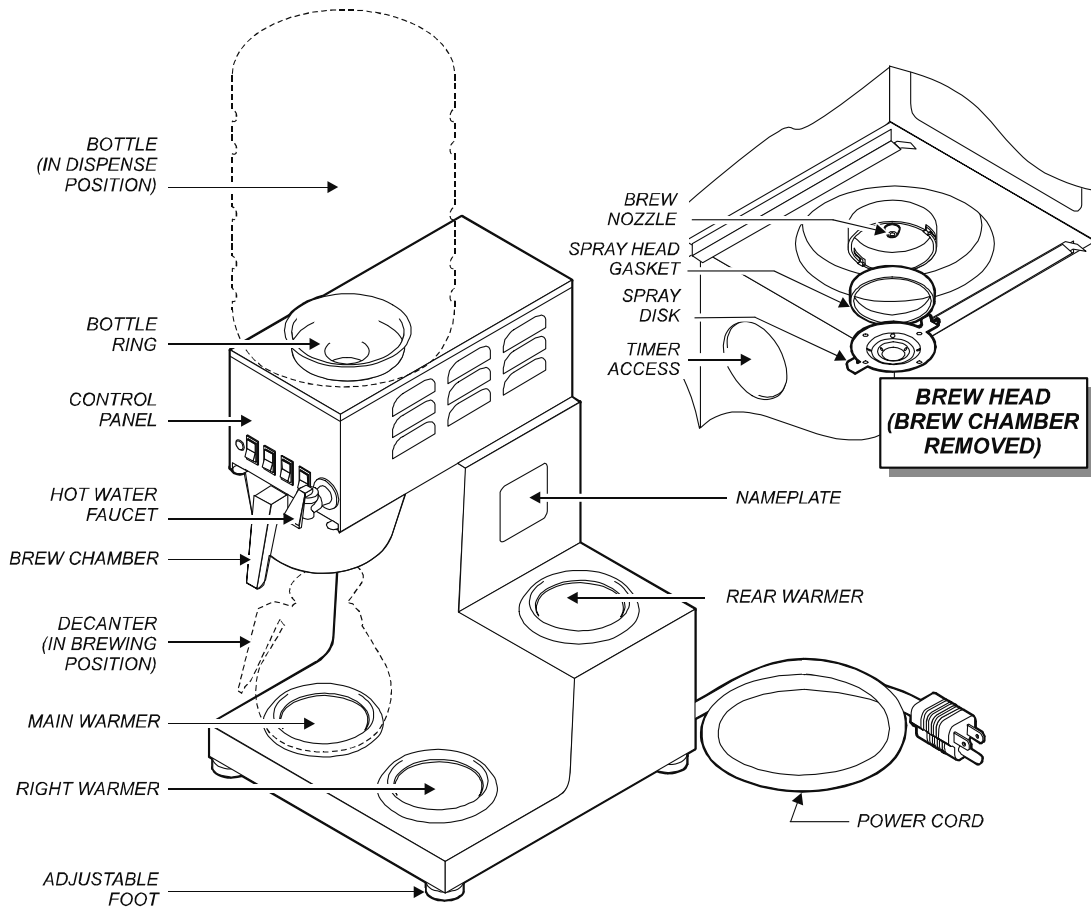

Fig. 1 Features & Operating Controls

## PRECAUTIONS AND GENERAL INFORMATION



### **WARNING: Electric Shock Hazard**

All servicing requiring access to non-insulated components must be performed by qualified service personnel. Do not open any access panels which require the use of tools. Failure to heed this warning can result in electrical shock.



### **WARNING Electric Shock Hazard**

Brewer must be plugged into a properly grounded receptacle to prevent possible shock. Electrical shock will cause death or serious injury.



### **WARNING: Burn Hazard**

This appliance dispenses very hot liquid. Serious bodily injury from scalding can occur from contact with dispensed liquids.

This appliance is intended for commercial use only.

This appliance is intended for use to brew beverage products for human consumption. No other use is recommended or authorized by the manufacturer or its agents.

This appliance is intended for use in commercial establishments, where all operators are familiar with the appliance use, limitations and associated hazards. Operating instructions and warnings must be read and understood by all operators and users.

Except as noted, this piece of equipment is made in the USA and has American sizes on hardware. All metric conversions are approximate and can vary in size.

The following trouble shooting, component views and parts lists are included for general reference, and are intended for use by qualified service personnel.

This manual should be considered a permanent part of this appliance. The manual must remain with the appliance if it is sold or moved to another location.



### **CAUTION: Equipment Electrical Damage**

DO NOT plug in or energize this appliance until all *Installation Instructions* are read and followed. Damage to the Brewer will occur if these instructions are not followed.



### **CAUTION: Burn Hazard**

Exposed surfaces of the appliance, brew chamber and decanter may be HOT to the touch, and can cause serious burns.

## AGENCY APPROVAL INFORMATION

This brewer is  and  listed under UL file E9253.

This brewer meets  Standard 4 only when installed, operated and maintained in accordance with the enclosed instructions.



## INSTALLATION INSTRUCTIONS

### READ THIS CAREFULLY BEFORE STARTING THE INSTALLATION

#### **IMPORTANT:**

To enable the installer to make a quality installation and to minimize installation time, the following suggestions and tests should be done before the actual unit installation is started:



#### **CAUTION: Equipment Electrical Damage**

DO NOT plug in or energize this appliance until all Installation Instructions are read and followed. Damage to the Brewer will occur if these instructions are not followed.



#### **CAUTION: Unstable Equipment Hazard**

It is very important for safety and for proper operation that the brewer is level and stable when standing in its final operating position. Provided adjustable, non-skid legs must be installed at each corner of the unit. Failure to do so will result in movement of the brewer which can cause personal injury and/or damage to brewer.



#### **WARNING ELECTRIC SHOCK HAZARD:**

Brewer must be plugged into a properly grounded electrical receptacle to prevent possible shock hazard. DO NOT assume a plumbing line will provide such a ground. Electrical shock will cause death or serious injury.

Unpack the unit. Inspect all components for completeness and condition. Ensure that all packing materials have been removed from the unit.

Verify that the Spray Head Gasket (#33) and Spray Disk (#34) are properly installed.

#### **LEVELING THE UNIT**

Verify that an adjustable leg is installed at each corner of the brewer.

Set Brewer in its operating location. Level the Brewer. A spirit level should be placed on the top of the unit, at the edge, as a guide when making level adjustments.

Level the unit from left to right and front to back by turning the adjustable feet. Be sure all four feet touch the counter to prevent tipping.

#### **FILL WATER TANK**

Check the bottle ring for lint or packing materials. Wipe the interior of the bottle ring with a cloth dampened with clean water.

Brewer is designed to use a 3 gallon or 5 gallon plastic water bottle. Carefully insert a fresh water bottle into the bottle ring.

Wait 30 seconds, or until all bubbling in the bottle stops, then drain water from the hot water faucet until all air is purged from the tank.

#### **ELECTRICIAN'S INSTALLATION INSTRUCTIONS**

REFER TO ELECTRICAL SPECIFICATIONS - Page 1  
Check the nameplate to determine correct electrical service required for the Brewer to be installed.

**IMPORTANT:** Before connecting to electricity, make sure a bottle of water is installed on the bottle ring, and all air has been bled from the water tank

**Model 8372** is equipped with a cord and plug. It requires a 115 - 125 volt 20 amp circuit (50/60 Hz, 2 wire plus ground, with NEMA 5-15R or 5-20R Receptacle).

#### **IMPORTANT:**

Supply power must match nameplate for voltage and phase. Connecting to the wrong voltage will damage the brewer or result in decreased performance. Such damage is not covered by warranty.

**IMPORTANT:** The ground prong of the plug is part of a system designed to protect you from electrical shock in the event of internal damage. Never cut off the ground prong nor twist a blade to fit an existing receptacle. Contact a licensed electrician to install the proper circuit and receptacle.

**START-UP**

For initial start-up, or if the brewer has not been used for an extended period of time:

- ◆ Be sure spray disk and brew gasket are properly installed in the brew head.
- ◆ Install a fresh bottle of water in the bottle ring.
- ◆ Allow basin and tank to fill.
- ◆ Plug unit into a properly grounded electrical receptacle.
- ◆ Draw water from the hot water faucet until all air is purged from the tank.

**NOTE:** This brewer will not function as a “pour-over” brewer. A water bottle with an adequate amount of water must be installed for the brewer to operate.

Once plugged into electrical power, the heating elements will begin heating the water in the tank. When the water has reached the proper temperature, the “READY TO BREW” light will glow.

**CAUTION:**  
 **Personal Injury**

5 Gallon water bottle can weigh up to 50 pounds. Install bottle carefully. Injury can result from improper lifting technique or from attempting to lift a full bottle without adequate physical ability.

**CAUTION:**  **Equipment Electrical Damage**

DO NOT manually fill brewer through bottle ring.

**IMPORTANT:** Use only 3 gallon or 5 gallon plastic water bottle.

**IMPORTANT:** Tank must be full of water before connecting brewer to electrical power. Heating elements will be damaged if allowed to operate without being fully submerged in water. Damage caused by operating the brewer without water in the tank is **NOT COVERED BY WARRANTY.**

**IMPORTANT:** This appliance is **NOT** designed to be used as a pour-over brewer. Operation without a water bottle with an adequate amount of water in place will produce very little or no brewed coffee.

**IMPORTANT:** When installing water bottle, be careful to not overflow the basin pan. **DO NOT** fill the basin pan prior to installing the water bottle.

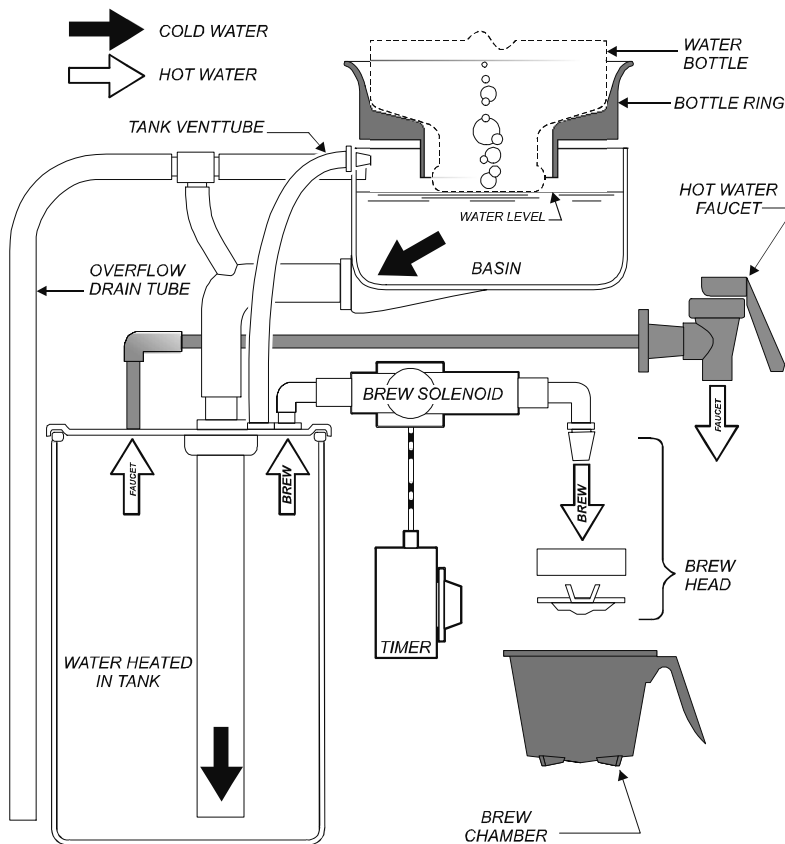

Fig 2. Brewer Operation Diagram

## OPERATION (continued)

### WATER HEATER

Water temperature is sensed by a thermobulb inserted into the water tank. This temperature signal is fed to the thermostat, which controls line power to the heating element.

The setpoint temperature is adjustable at the thermostat.

The element is protected from over-temperature by a hi-limit thermostat.

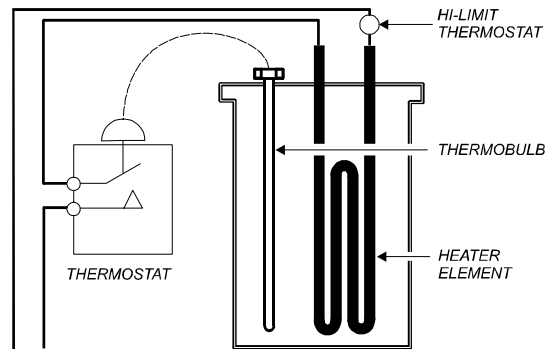

Fig. 3 Heat Control Diagram

### WATER FLOW

#### AUTOMATIC OPERATION

Water is supplied to the hot water tank by a bottle inserted in the bottle ring. Water will flow from the bottle into the basin pan until the water level reached the open mouth of the bottle.

Pressing BREW button energizes the solenoid valve, allowing heated water from the hot water tank to flow through the spray head into the brew chamber.

The length of time the solenoid is open is controlled by the timer.

#### HOT WATER FAUCET

The hot water faucet draws heated water from the water tank.

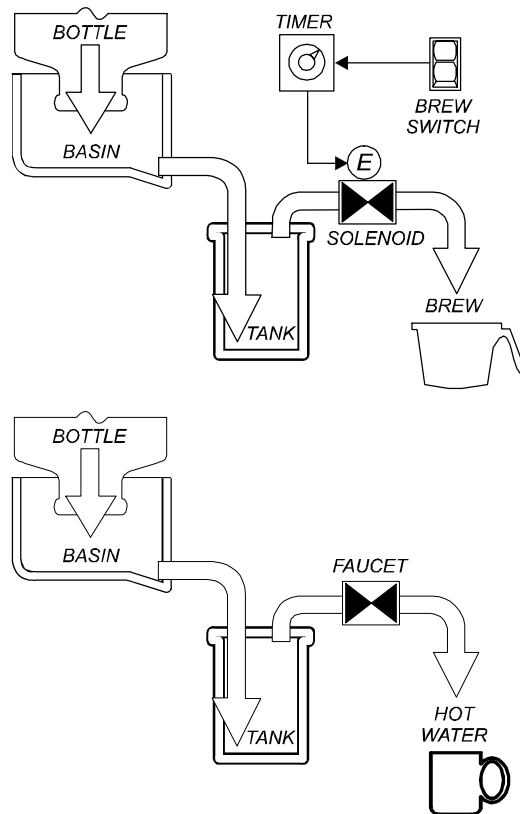

Fig. 4 Water Flow Diagrams



## BREWING COFFEE

### PREPARATION

Place one (1) genuine Bloomfield paper filter in the brew chamber. Add a pre-measured amount of fresh coffee grounds.

Gently shake the brew chamber to level the bed of grounds. Slide the brew chamber into place under the brew head.

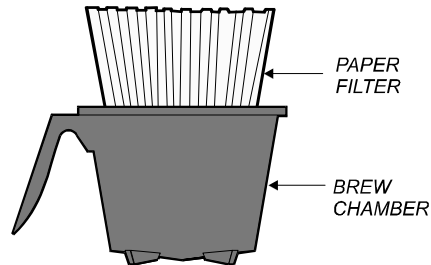

Fig. 5 Brew Chamber

### AUTOMATIC OPERATION

BE sure "READY TO BREW" light is lit.

Place an *EMPTY* decanter in place under the brew chamber.

Press the "BREW" switch. The solenoid will open for an amount of time determined by the timer setting, admitting a measured quantity of hot water into brew head, where it will spray over the bed of grounds.

When the flow and all dripping stops, the coffee is ready to serve.

Discard the contents of the brew chamber and rinse it in a sink. When the "READY TO BREW" light comes on, the brewer is ready for another brew cycle.



**CAUTION:**  
Burn Hazard

Exposed surfaces of the brewer, brew chamber and decanter may be HOT to the touch, and can cause serious burns.



**CAUTION:**  
Burn Hazard

To avoid splashing or overflowing hot liquids, ALWAYS place an empty decanter under the brew chamber before starting the brew cycle. Failure to comply can cause serious burns.



**CAUTION:**  
Burn Hazard

After a brew cycle, brew chamber contents are HOT. Remove the brew chamber and dispose of used grounds with care. Failure to comply can cause serious burns.

NOTE: Use of the hot water faucet will not affect the volume of water delivered for a brew. However, overuse of the faucet during a brew may lower the temperature of the brew water.

## CLEANING INSTRUCTIONS



### CAUTION: Burn Hazard

Brewing and serving temperatures of coffee are extremely hot. Hot coffee will cause serious skin burns.



### CAUTION: Electric Shock Hazard

Do not submerge or immerse brewer in water.

### IMPORTANT:

DO NOT use steel wool, sharp objects, or caustic, abrasive or chlorinated cleansers to clean the brewer.

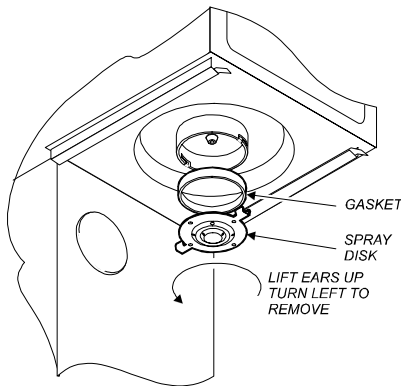

Fig. 6 Cleaning

## PROCEDURE: Clean Coffee Brewer

PRECAUTIONS: Disconnect brewer from electric power.  
Allow brewer to cool.

FREQUENCY: Daily

TOOLS: Mild Detergent, Clean Soft Cloth or Sponge  
Bristle Brush.

1. Disconnect brewer from electric power. Allow brewer to cool before cleaning.
2. Remove and empty decanters.
3. Remove and empty brew chamber.
4. Remove the spray disk from the brew head (See figure 6): Press up on the spray disk ears, then turn the disk to the left to unlatch. Remove the gasket from inside the brew head.
5. Wipe inside of brew head and area around the brew head with a soft clean cloth or sponge moistened with clean water.
6. Wash the spray disk in a sink using warm water and a mild detergent. A bristle brush may be used to clear clogged spray holes. Rinse the spray disk with clean water and allow to air dry.
7. Wash the brew chamber in a sink using warm water and a mild detergent. A bristle brush may be used to clean the inside. Rinse with clean water and allow to air dry. For stainless steel brew chambers, be sure the wire rack is properly reinstalled.
8. Wipe the exterior of the brewer with a soft clean cloth or sponge moistened with clean water.
10. Reinstall the gasket *INSIDE* the brew head, then reinstall the spray disk.
11. Reinstall the brew chamber.
12. Decanters may be washed in a dishwasher or sink.

Procedure is complete

## CLEANING INSTRUCTIONS (continued)

### PROCEDURE: Clean and Sanitize Basin Pan

**PRECAUTIONS:** Disconnect brewer from electric power.  
Allow brewer to cool.

**FREQUENCY:** Monthly

**TOOLS:** #2 Phillips Head Screwdriver  
Mild Detergent, Food Equipment Sanitizer  
Clean Soft Cloth or Sponge



**CAUTION:**  
Electric Shock  
Hazard

Removing the top panel will expose uninsulated circuits. Unplug the brewer before removing the top panel. This procedure to be performed by a qualified person only.

1. Disconnect brewer from electric power. Allow brewer to cool before cleaning.
2. Remove and empty decanters and brew chamber.
3. Remove water bottle. Drain water from hot water faucet until water no longer flows.
4. Remove four screws holding the top panel in place. Remove the top panel. **DO NOT** remove the bottle ring from the top panel.
5. Remove basin seal by working it out from under the flange at the top of the brewer body.
6. Remove the silicone outlet elbow, overflow drain and vent tube from basin pan. Remove the basin pan from the brewer.
7. Wash the basin pan and bottle ring with a clean cloth and mild detergent.
7. Soak the basin pan, basin seal and top panel in sanitizer per the directions supplied with the sanitizer.
8. Rinse the basin pan, basin seal and top panel with clean water. Dry thoroughly with a clean cloth.
9. Reinstall the basin pan in brewer, making sure the vent tube, overflow tube and outlet elbow are properly installed.
10. Reinstall basin seal, gasket side up, under the flange in the top of the brewer body.
11. Reinstall the top panel. Install a water bottle in the bottle ring. Drain water from the hot water faucet to purge air from the system.

Procedure is complete

### IMPORTANT:

**DO NOT** use steel wool, sharp objects, or caustic, abrasive or chlorinated cleansers to clean basin pan or cabinet panels.

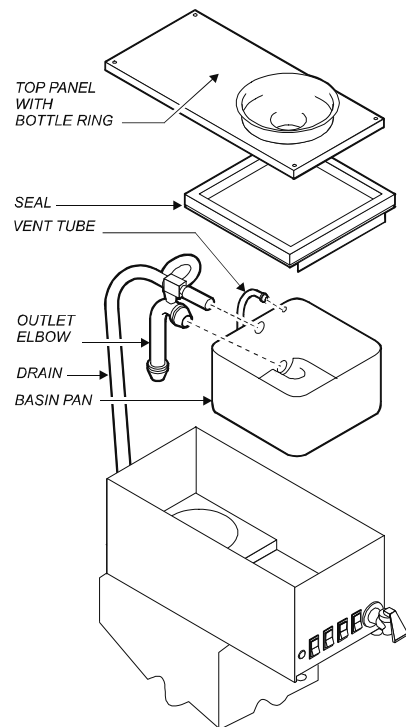

Fig. 7 Top Panel & Basin Pan

## TROUBLESHOOTING SUGGESTIONS

SYMPTOM	POSSIBLE CAUSE	SUGGESTED REMEDY
Water won't heat	Brewer unplugged or circuit breaker tripped	Check power supply cord Check / reset circuit breaker
	Thermostat set too low	Set for desired temperature
	Hi-Limit thermostat tripped	Allow to cool Reset hi-limit (8786, 8788)
	Damaged internal component or wiring	Examine wiring & connectors, thermostat and heating element Repair/replace as needed
Coffee level low	Water bottle empty	Replace water bottle
	Too much coffee grounds	Adjust amount of grounds
Coffee level too high or low	Timer out of adjustment	Adjust timer
Brew chamber overflows	Too many filter papers or wrong filter paper	Use one (1) genuine Bloomfield filter per brew
	Brew chamber dispense hole plugged	Thoroughly clean brew chamber
	Too much coffee or too fine a grind	Adjust coffee amount and grind
Sprays water from brew head	Spray gasket improperly installed	Check/reinstall gasket on INSIDE of brew head
	Spray disk plugged	Plug into electrical power
No brew	Brewer not plugged in	Clean spray disk
	Water bottle empty	Replace water bottle
	Bad BREW switch	Replace switch
	Damaged internal component or wiring	Examine wiring & connectors, brew switch and solenoid Repair/replace as needed
No flow from hot water faucet	Water bottle empty	Replace water bottle
Brewer overflows from basin	Damaged water bottle	Install new water bottle
Poor coffee quality	Water not hot enough	Adjust water temp 195-205°F
	Suggestions for consistently good coffee: Keep brewer clean. Use a quality coffee with a consistent roast. Use proper grind and amount of coffee per brew.	

## SERVICING INSTRUCTIONS

### ACCESS PANELS

Top panel is held by four screws at the corners.

Front panel is held by two clips under each warmer plate, three screws at the bottom and a retaining lip at the top.

Top rear panel is held by two clips under the warmer plate.

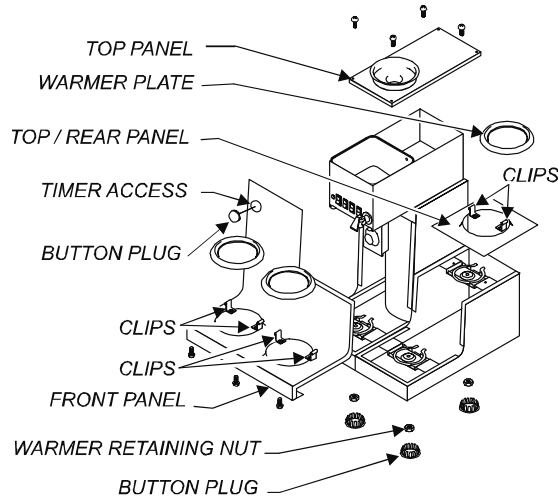

Fig. 8 Access Panels

### TEMPERATURE ADJUSTMENT

With the "READY TO BREW" light ON, draw a cup of water from the hot water faucet. Check the temperature of the water with a thermometer of known accuracy.

If temperature adjustment is necessary, remove water bottle and top panel.

Adjust thermostat by turning shaft; clockwise increases temperature. 1/8 turn = approximately 10°F.

Refer to Table 1 below for proper brewing temperature based on altitude.

Upon completion, reinstall top panel.

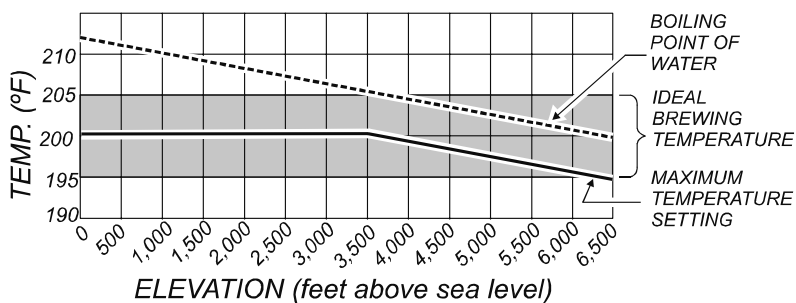

Table 1 Boiling Temperature by Altitude



**CAUTION**  
Electric Shock  
Hazard

Opening access panels or removing warmer plates on this brew may expose uninsulated electrical components. Disconnect brewer from electrical power before removing any panel or warmer plate.

#### NOTE:

Each warmer plate has a center stud which screws into a bracket. Warmer plates on Canadian brewers are secured with a nut. Remove button plug on bottom of brewer to access nut on warmer plate. Remove warmer plates by turning counter-clockwise.

#### NOTE:

Optimum brewing temperature range is 195°F to 205°F (90°C to 96°C).

#### IMPORTANT:

A mechanical thermostat will maintain temperature within  $\pm 5^\circ\text{F}$ . To prevent boiling water in the brewer, thermostat should be adjusted to a maximum temperature equal to the local boiling temperature minus 5°F.

**IMPORTANT:** Adjust timer with a full water bottle installed in the bottle ring.

**IMPORTANT:** Before setting assembly into tank, make sure tank lid gasket is properly seated on flange of lid.  
*DO NOT OVER-TIGHTEN.*

**IMPORTANT:** When removing tank lid assembly, be careful to not damage or kink thermostat capillary tube.

**IMPORTANT:** When mounting thermostat, be sure a new seal washer is placed below the fitting on the capillary line. Push sensing bulb thru tank lid until fitting seats. Tighten capillary lock nut only enough to ensure no water leakage. Excessive tightening is not necessary.

### TIMER ADJUSTMENT

The amount of water dispensed automatically during a brew cycle is controlled by the timer.

Place empty decanter under brew chamber. Press BREW button. Brewer should dispense one decanter of water. To adjust amount:

Remove brew chamber and button plug. Adjust knob on timer; clockwise increases time. Run several cycles to check amount of water delivered. Replace button plug.

### REMOVE TANK LID ASSEMBLY

Unplug brewer or turn circuit breaker *OFF*. Remove water bottle. Run water from the hot water faucet until no more water flows. Remove top panel. Siphon water from the tank through the faucet supply fitting until the water level in the tank is below the tank lid.

Pull vent tube and inlet elbow out of basin pan. Remove basin pan.

Disconnect faucet supply from tank lid.

Disconnect wires from thermostat. Remove screws holding thermostat to bracket. Do not remove thermobulb from tank lid. Thermostat is removed with the tank lid.

Disconnect all wiring from heating element. Slide hi-limit out of the way.

Loosen center screw on tank hold-down bracket and loosen acorn nuts. Remove hold-down bracket by sliding short slotted end off of locking stud and lifting it off. Remove tank lid assembly by lifting it straight up.

Reassemble in reverse order.

### REPLACE THERMOSTAT

Unplug brewer or turn circuit breaker *OFF*. Remove water bottle and drain water from hot water faucet until no more water flows. Remove top panel.

Disconnect all wiring from thermostat only. Loosen and free jam nut from pass-thru fitting securing temperature sensing bulb. Remove two screws holding thermostat to bracket.

Lift out thermostat, sensing bulb and thermostat gasket.

Reassemble in reverse order.

**REPLACE HEATING ELEMENT**

Remove tank lid assembly per above.

Remove two hex nuts holding element to cover. Pull element from mounting holes.

Reassemble in reverse order.

**REPLACE WARMER ELEMENT**

Remove warmer plate by turning counter-clockwise.

Lift element from bracket. Disconnect wiring.

Reassemble in reverse order.

**REPLACE SOLENOID**

Symptom: brewer will not flow water; or, brewer drips continuously from brew head.)

Unplug power cord or turn circuit breaker *OFF*. Turn *OFF* and disconnect water supply from brewer inlet fitting.

Remove water bottle and top panel.

Cut tie straps from solenoid hose connections. Remove wiring connections from solenoid coil. Remove solenoid

Reassemble in reverse order.

**REPLACE TIMER ASSEMBLY**

Unplug power cord or turn circuit breaker *OFF*.

Remove front panel. Remove knob and three screws holding timer to bracket. Disconnect wiring to timer.

Reassemble in reverse order.

Adjust timer as described on page 12.

**REPLACE BREW READY LIGHT, BREW SWITCH OR WARMER SWITCH**

Unplug power cord or turn circuit breaker *OFF*.

Remove water bottle, top panel and basin pan.

Using Switch Removal Tool (p/n 83209) or a thin screwdriver, pry light or switch from mounting hole. Disconnect leads.

Reassemble in reverse order.

**IMPORTANT:** When replacing heating element, also replace seal gaskets.

## SERVICING INSTRUCTIONS (continued)



### CAUTION - CHEMICAL BURN HAZARD

Deliming chemicals are caustic. Wear appropriate protective gloves and goggles during this procedure.

Never siphon deliming chemicals or solutions by mouth.

This operation should only be performed by qualified and experienced service personnel.

---

**IMPORTANT:** DO NOT spill, splash or pour water or deliming solution into or over any internal component other than the inside of the water tank.

---

**IMPORTANT:** DO NOT allow any electrical wiring or components to come into contact with the deliming solution. Take care to keep all electrical components and wiring dry.

**NOTE:** Repeat steps 4 thru 5 as required to remove all scale and lime build-up.

### PROCEDURE: Delime the Water Tank

**PRECAUTIONS:** Disconnect brewer from electric power. Allow brewer to cool.

**FREQUENCY:** As required (Brewer slow to heat)

**TOOLS:** Deliming Solution  
Protective Gloves, Goggles & Apron  
Mild Detergent, Clean Soft Cloth or Sponge  
Bristle Brush, Bottle Brush  
Large Sink (or other appropriate work area)

1. Disconnect brewer from the electrical supply. Remove the water bottle and drain the tank by running water from the hot water faucet until no more water flows.
2. Remove the tank lid assembly as described on page 12.
3. Remove the water tank from the brewer body by lifting straight up. Empty all water from the tank. Set the tank back into the brewer.
4. Mix 2 quarts of deliming solution according to the manufacturer's directions. Carefully pour the deliming solution into the water tank. Lower the lid assembly back onto the tank. Allow to sit for 30 minutes, or as directed by the manufacturer.
5. At end of soaking period, remove lid assembly from tank. Thoroughly rinse internal components of lid assembly with clear water. Using a stiff bristle brush, scrub the heating element to remove lime and calcium build-up. Rinse with clean water. Store lid assembly in a safe location .
6. Remove the tank from the brewer and empty. Using a stiff bristle brush, scrub the interior of the water tank to remove lime and calcium build-up. Rinse with clean water.



## SERVICING INSTRUCTIONS (continued)

7. Set the tank back into the brewer. Reassemble the tank lid to the water tank. Make sure the gasket is properly in place, then reinstall the hold-down strap.
8. Reinstall wiring to heating element and thermostat. Reinstall the hi-limit thermostat . Verify that all internal components are dry, then reinstall the top panel.
10. Reconnect brewer to electrical supply.
11. Install the brew chamber without filter paper or grounds. Run at least three full brew cycles and discard all water generated.
12. Brewer is ready to use.

**NOTE:** Normally, silicone hoses do not need to be delimed. Should deliming hoses become necessary, Bloomfield recommends replacing the hoses.

## EXPLODED VIEW & PARTS LIST

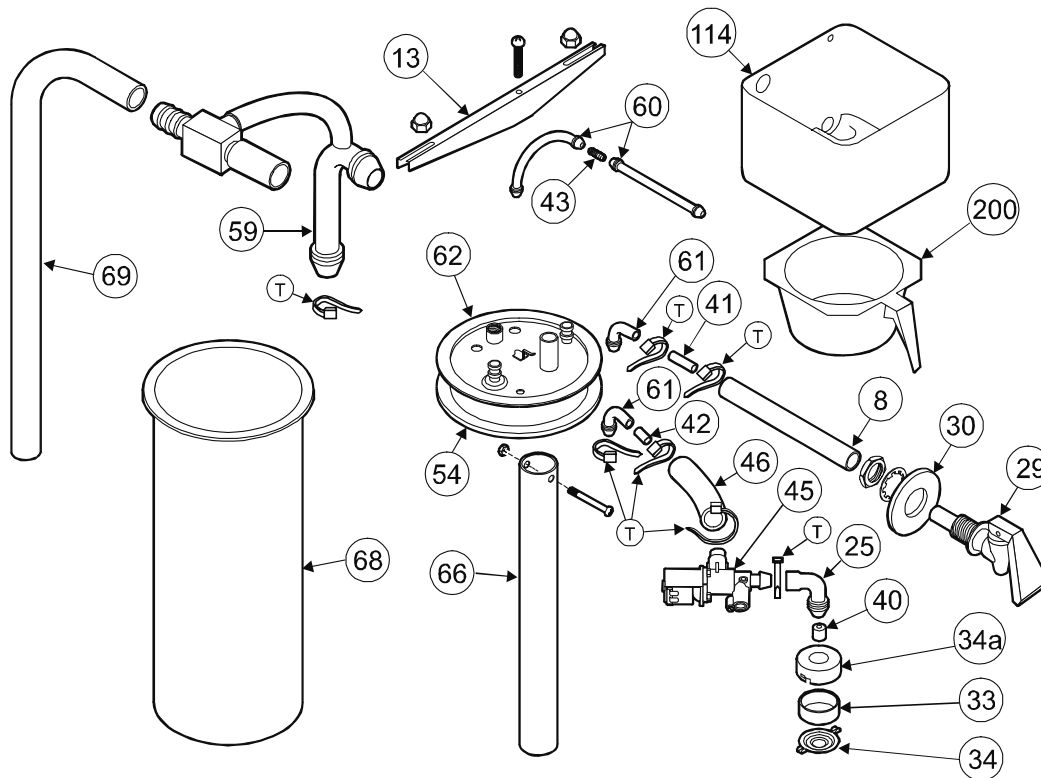

### 8372 PLUMBING COMPONENTS

ITEM	PART#	DESCRIPTION	QTY
8	83538	TUBE, FAUCET SUPPLY 10" SILICONE	1
13	8043-5	STRAP, TANK LID HOLD DOWN	1
25	8043-13	ELBOW, BREW NOZZLE SILICONE	1
29	8783-1	FAUCET	1
30	82681	WASHER, FLAT SS 15/32 x 1-1/8 OD	1
33	8543-42	GASKET, SPRAY DISK	1
34	84132	SPRAY DISK	1
34a	8543-45	BREW HEAD (must be drilled & riveted to install)	1
40	8810-70	RESTRICTOR, BREW NOZZLE	1
41	83384	TUBE, FAUCET SUPPLY METAL	1
42	85609	INSERT, BREW OUTLET ELBOW	1
43	82241	FITTING, BARBED BRASS	1
45	83388	SOLENOID, BREW 120V	1
46	85634	TUBE, BREW SILICONE	1
54	8043-12	GASKET, TANK LID	1
59	86771	INLET & VENT TUBE ASSY	1
60	8043-15	TUBE, VENT SILICONE	2
61	8043-11	ELBOW, OUTLET SILICONE	2
62	85587	TANK LID ASSEMBLY	1
66	8043-24	TUBE, TANK WATER INLET METAL	1
68	8043-10	TANK BODY	1
69	83385	TUBE, OVERFLOW DRAIN SILICONE	1
114	8760-3	BASIN PAN	1
200	8942-6B	BREW CHAMBER BLACK PLASTIC	1
T		CABLE TIE, PLASTIC	8

EXPLODED VIEW & PARTS LIST (continued)

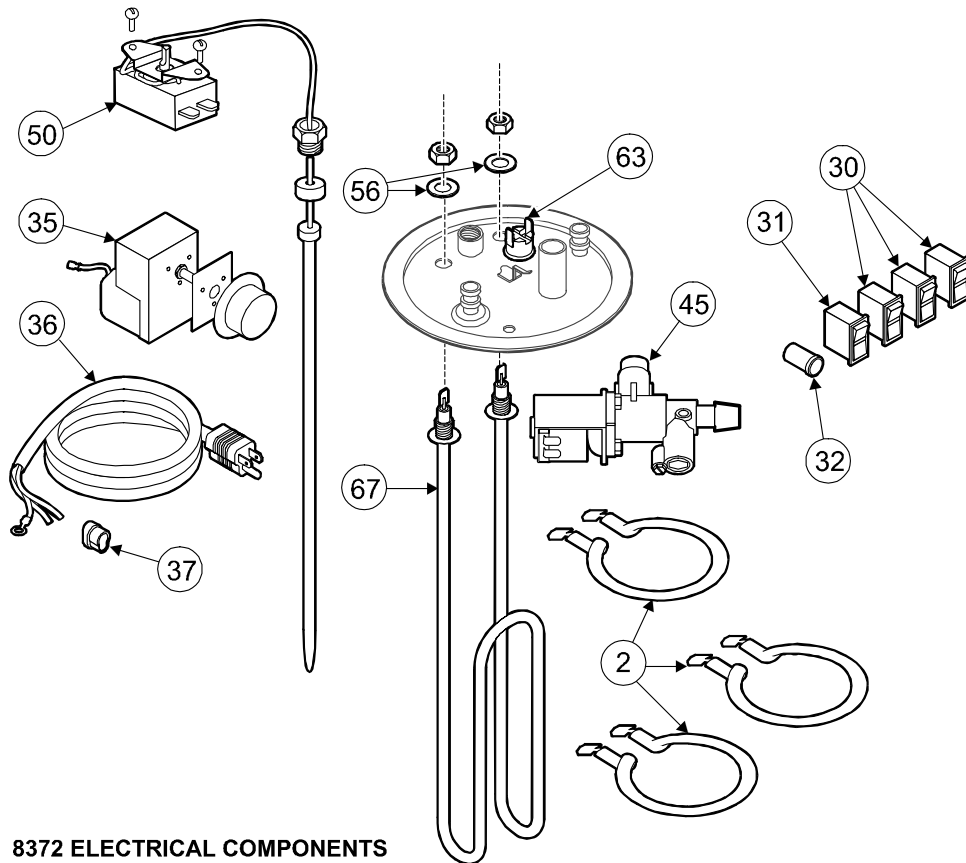

8372 ELECTRICAL COMPONENTS

ITEM	PART#	DESCRIPTION	QTY
2	8572-18	WARMER, 120V 100W	3
30	85647	SWITCH, WARMER ON/OFF 120V	3
31	85646	SWITCH, BREW MOMENTARY 120V	1
32	8718-31	INDICATOR LIGHT, GREEN 120V	1
35	8812-61	TIMER, 8 MIN	1
36	6407-15	POWER CORD, NEMA 5-15P	1
37	35-210	STRAIN RELIEF	1
45	83388	SOLENOID, BREW 120V	1
50	86280	THERMOSTAT, 199°F	1
56	8043-30	SEAL, HEATING ELEMENT	2
63	8043-83	THERMOSTAT, HI-LIMIT 120V	1
67	8043-14	HEATING ELEMENT, 120V 1500W	1
	✦8043-93	HEATING ELEMENT, 120V 1200W	

## EXPLODED VIEW & PARTS LIST (continued)

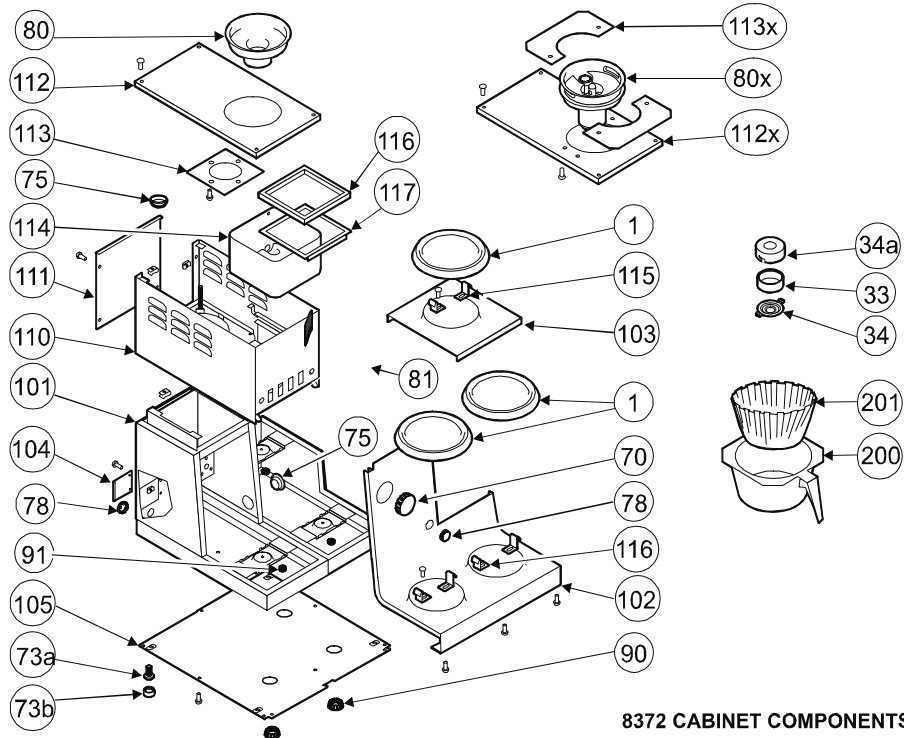

8372 CABINET COMPONENTS

ITEM	PART#	DESCRIPTION	QTY
1	8700-16	PLATE, WARMER COVER	3
33	8543-42	GASKET, SPRAY DISK	1
34	84132	SPRAY DISK	1
34a	8543-45	BREW HEAD (must be drilled & riveted to install)	1
70	8706-75	BUTTON PLUG, 2" DIA	1
73	81732	LEG ADJUSTABLE	4
73a	8033-55	LEG, METAL	
73b	8033-56	FOOT, RUBBER	
75	8543-69	BUSHING, SHORTY HEYCO	2
78	8810-12	BUTTON PLUG 7/8" DIA	2
80	85583	BOTTLE RING (Model 8372)	1
80x	3300	BOTTLE RING, OASIS (Model 8372OR)	1
81	80629	LABEL	1
90	8706-76	BUTTON PLUG 1-1/8"	3 (8372CA)
91	18-50	NUT, WARMER PLATE RETAINING 1/4-28	3 (8372CA)
101		BASE, BODY ASSEMBLY	1
102		BASE, LOWER FRONT PANEL	1
103		BASE, UPPER FRONT PANEL	1
104		BASE, DOOR	1
105	8572-66	BASE, BOTTOM PANEL	1 (8372)
	8571-19	BASE, BOTTOM PANEL w/ACCESS HOLES	1 (8372CA)
110		BASIN, BODY ASSEMBLY	1
111		BASIN, REAR PANEL	1
112		BASIN, TOP COVER(Model 8372)	1
112x		BASIN, TOP COVER(Model 8372OR)	1
113		RETAINER, BOTTLE RING (Model 8372)	1
113x		RETAINER, BOTTLE RING (Model 8372OR)	1
114	8760-3	BASIN PAN	1
115	8543-80	CLIP, RETAINING	6
116		BASIN PAN SEAL GASKET	1
117		BASIN PAN SEAL	1
200	8942-6B	BREW CHAMBER BLACK PLASTIC	1
201	POF	FILTER PAPER (case of 1000)	A/R

WIRING DIAGRAM

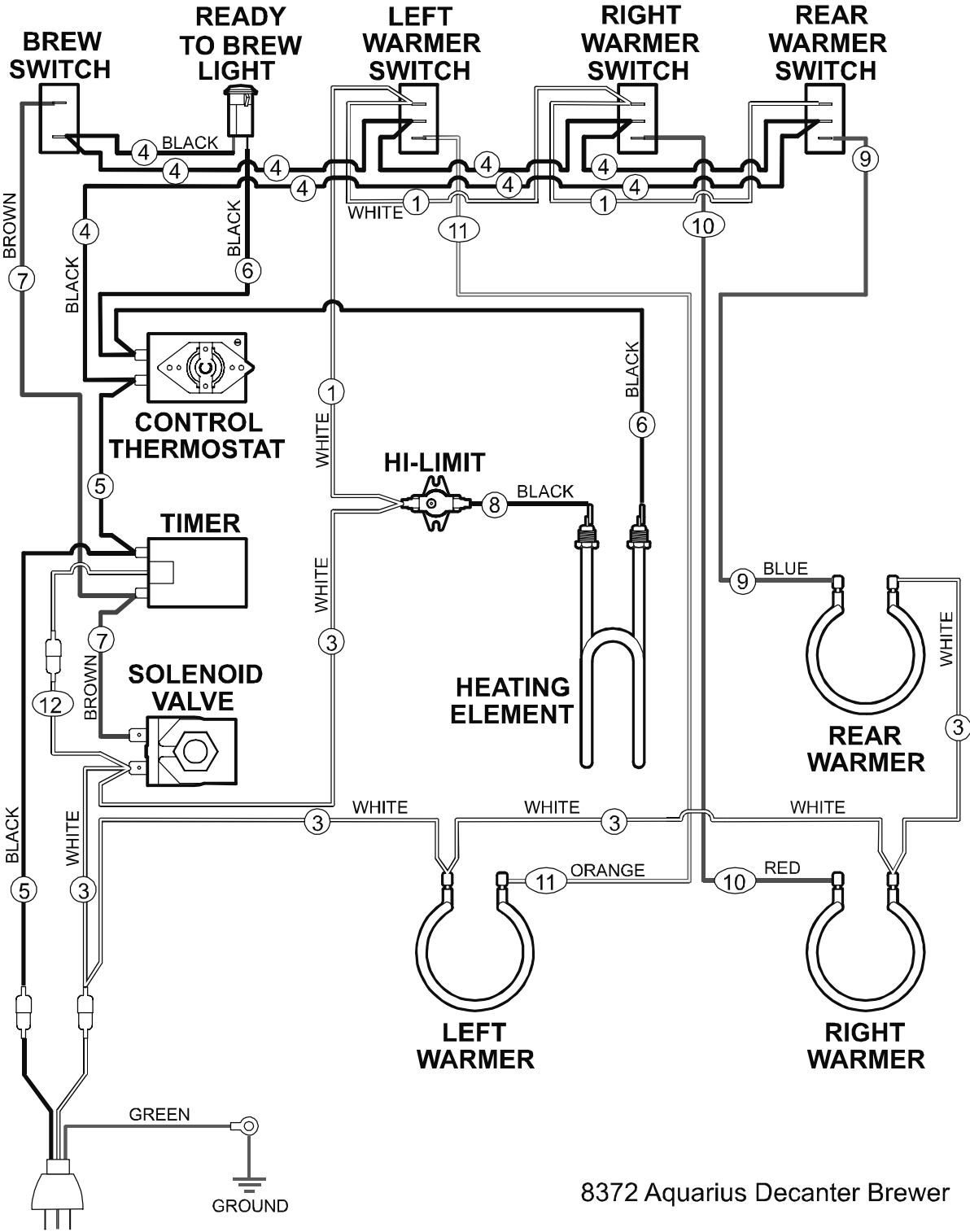

# **CFESA**

Commercial Food Equipment Service Association

Bloomfield Industries proudly supports CFESA  
Commercial Food Equipment Service Association

**SERVICE TRAINING - QUALITY SERVICE**



**CUSTOMER SATISFACTION**



**BLOOMFIELD**

**Bloomfield Industries, Inc.**  
**Division of Carrier Commercial Refrigeration**

**In US and Canada**

Telephone: 775-689-5700

Fax: 888-492-2783

Fax: 800-356-5142 (*for orders only*)

website: [www.wellsbloomfield.com](http://www.wellsbloomfield.com)

**PRINTED IN UNITED STATES OF AMERICA**