

10 Sunnen Drive  
St. Louis, MO 63143  
telephone: 314-678-6336  
fax: 314-781-2714  
[www.bloomfieldworldwide.com](http://www.bloomfieldworldwide.com)



*Model 8774 Brewer  
with optional  
8881 Airpot*



*Model 8773 Brewer  
with optional  
7760 Airpot*

**OWNERS MANUAL  
For  
INTEGRITY™  
COFFEE BREWERS**

**MODELS**

**8773 Automatic Airpot Brewer**

**8774 Pour-Over Airpot Brewer**

**Domestic and  
Export Models**

**Includes:**

**Installation  
Use & Care  
Servicing Instructions**

## WARRANTY STATEMENT

All equipment manufactured by Bloomfield is warranted against defects in materials and workmanship for the time periods listed in the chart starting from the date the equipment is placed into service and is for the benefit of the original purchaser:

THE FOREGOING OBLIGATION IS EXPRESSLY GIVEN IN LIEU OF ANY OTHER WARRANTIES, EXPRESSED OR IMPLIED, INCLUDING ANY IMPLIED WARRANTY OF MERCHANTABILITY OR FITNESS FOR A PARTICULAR PURPOSE, WHICH ARE HEREBY EXCLUDED.

BLOOMFIELD, LLC SHALL NOT BE LIABLE FOR INDIRECT, INCIDENTAL OR CONSEQUENTIAL DAMAGES OR LOSSES FROM ANY CAUSE WHATSOEVER.

This warranty is void if it is determined that upon inspection by an authorized service agency that the equipment has been modified, misused, misapplied, improperly installed, or damaged in transit or by fire, flood or act of God.

It also does not apply if the serial nameplate has been removed or unauthorized service personnel perform service. The prices charged by Bloomfield for its products are based upon the limitations in this warranty. Seller's obligation under this warranty is limited to the repair of defects without charge by a Bloomfield Authorized Service Agency or one of its sub-agencies. This service will be provided on customer's premises for non-portable models. Portable models (a device with a cord and plug or a dispenser) must be taken or shipped to the closest authorized service agency, transportation charges prepaid, for services.

Agencies are located in principal cities, please visit our website to locate one.

This warranty is valid in the United States and Canada and void elsewhere. Please consult your classified telephone directory or your food service equipment dealer; or, for information and other details concerning warranty, write to:

Service Parts Department; Bloomfield  
10 Sunnen Drive, St. Louis, MO 63143  
**Phone: (314) 678-6336 : Fax: (314) 781-2714**  
Technical@ bloomfieldworldwide.com / www.bloomfieldworldwide.com

Equipment	Parts	Labor
pour over, automatic coffee brewers	2 yrs.	2 yrs.
EBC, EMAX coffee brewers	2 yrs.*	2 yrs.
* EBC, EMAX coffee brewer control	3 yrs.	no labor
POD coffee brewers	1 yr.	1 yr.
ECO coffee brewers	1 yr.	1 yr.
coffee warmers	1 yr.	1 yr.
tea brewers	2 yrs.	2 yrs.
tea dispensers	1 yr.	1 yr.
tea dispenser BBTea	1 yr.	no labor
hot water machines	2 yrs.	2 yrs.
thermal servers	90 days	no labor
airpots	30 days	no labor
decanter	no warranty	no warranty

### BLOOMFIELD SERVICE POLICY AND PROCEDURE GUIDE ADDITIONAL WARRANTY EXCLUSIONS

- Resetting of safety thermostats, circuit breakers, overload protectors, or fuse replacements.
- All problems due to operation at voltages other than specified on equipment nameplates - conversion to correct voltage must be the customer's responsibility.
- All problems due to electrical connections not made in accordance with electrical code requirements and wiring diagrams supplied with the equipment.
- Replacement of items subject to normal wear, to include such items as knobs and light bulbs. Normal maintenance functions including adjustment of thermostats, microswitches, and replacement of fuses and indicating lights are not covered under warranty.
- All problems due to inadequate water supply, such as fluctuating, or high or low water pressure.
- All problems due to mineral/calcium deposits, or contamination from chlorides/chlorines. De-liming is considered a preventative maintenance function and is not covered by warranty.
- Full use, care and manuals may or may not be sent with each unit, only a condensed version. Please visit our web site to download the full version.
- Travel mileage is limited to fifty (50) miles from an authorized service agency or one of its sub-service agencies.
- All labor shall be performed during normal working hours. Overtime premium shall be charged to the customer.
- All genuine Bloomfield replacement parts are warranted for ninety (90) days from date of purchase on non-warranted equipment. **Any use of non-genuine Bloomfield parts completely voids any warranty.**
- Installation, labor and job checkouts are not considered warranty.
- Charges incurred by delays, waiting time or operating restrictions that hinder the service technicians ability to perform services are not covered by warranty. This includes institutional and correctional facilities.

### SHIPPING DAMAGE CLAIMS PROCEDURE

**NOTE:** For your protection, please note that equipment in this shipment was carefully inspected and packaged by skilled personnel before leaving the factory. Upon acceptance of this shipment, the transportation company assumes full responsibility for its safe delivery.

#### IF SHIPMENT ARRIVES DAMAGED:





- VISIBLE LOSS OR DAMAGE:** Be certain that any visible loss or damage is noted on the freight bill or express receipt, and that the note of loss or damage is signed by the delivery person.
- FILE CLAIM FOR DAMAGE IMMEDIATELY:** Regardless of the extent of the damage.
- CONCEALED LOSS OR DAMAGE:** if damage is unnoticed until the merchandise is unpacked, notify the transportation company or carrier immediately, and file "CONCEALED DAMAGE" claim with them. This must be done within fifteen (15) days from the date the delivery was made to you. Be sure to retain the container for inspection.

Bloomfield cannot assume liability for damage or loss incurred in transit. We will, however, at your request, supply you with the necessary documents to support your claim.

## TABLE OF CONTENTS

WARRANTY STATEMENT	xi	Thank You for purchasing this Bloomfield appliance.
SPECIFICATIONS	1	
FEATURES & OPERATING CONTROLS	2	Proper installation, professional operation and consistent maintenance of this appliance will ensure that it gives you the very best performance and a long, economical service life.
PRECAUTIONS & GENERAL INFORMATION	3	
AGENCY LISTING INFORMATION	3	
INSTALLATION INSTRUCTIONS	4	
OPERATION	6	
BREWING COFFEE	8	
CLEANING INSTRUCTIONS	9	
TROUBLESHOOTING SUGGESTIONS	10	
SERVICING INSTRUCTIONS	11	
Deliming Instructions	16	
EXPLODED VIEWS & PARTS LISTS	18	This manual contains the information needed to properly install this appliance, and to use, care for and maintain or repair the appliance in a manner which will ensure its optimum performance.
SERVICE KITS	22	
WIRING DIAGRAMS	23	

## SPECIFICATIONS

MODEL	STYLE	VOLTS 1 $\emptyset$	WATTS	AMPS	POWER SUPPLY CORD
8773 	POUR-OVER plus AUTOMATIC W/HOT WATER FAUCET	120	1500	12.5	NEMA-5-15P
8773AU		240	1800	7.5	SUPPLIED
8773EU  8773UK		220-240	1800	7.5	
8774 	POUR-OVER ONLY	120	1500	12.5	NEMA-5-15P
8774AU		240	1800	7.5	SUPPLIED
8774EU  8774UK		220-240	1800	7.5	
8774KO		220	1500	6.9	



Also meets Canadian standards.



Meets European standards

# FEATURES AND OPERATING CONTROLS

## INTEGRITY™ AIRPOT BREWER

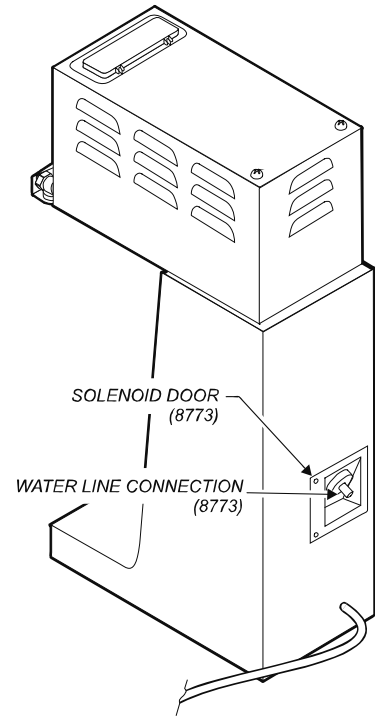
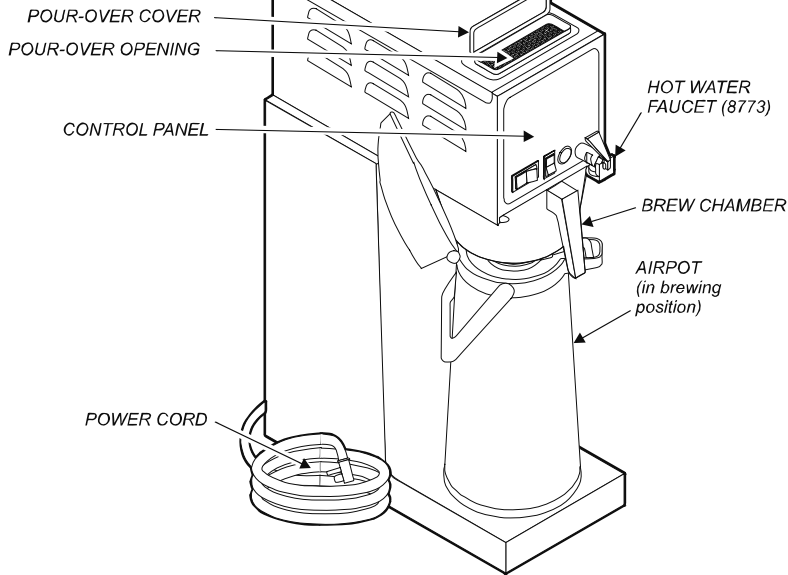

## BREW HEAD (BREW CHAMBER REMOVED)

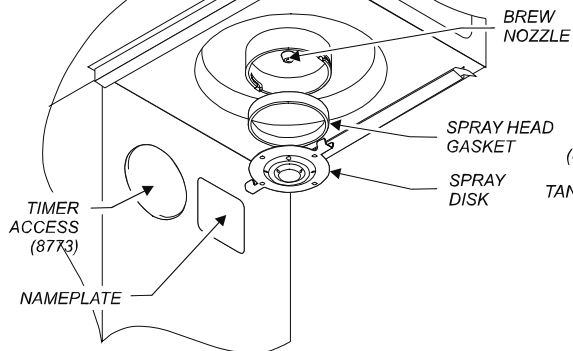

## CONTROL PANEL 8773 shown 8774 similar

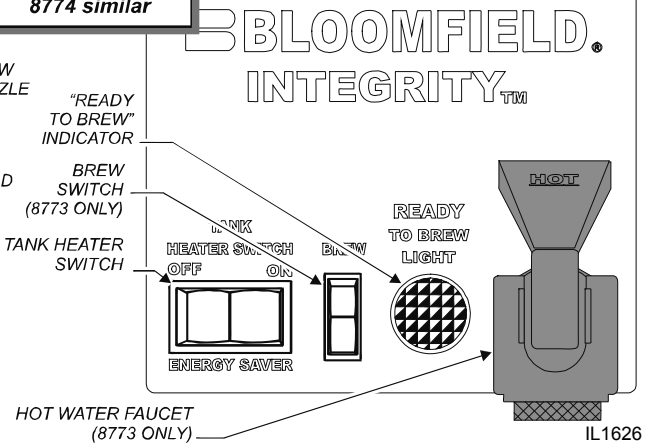

Fig. 1 Features & Operating Controls

## PRECAUTIONS AND GENERAL INFORMATION



### **WARNING: ELECTRIC SHOCK HAZARD**

All servicing requiring access to non-insulated components must be performed by qualified service personnel. Do not open any access panels which require the use of tools. Failure to heed this warning can result in electrical shock.



### **WARNING: INJURY HAZARD**

All installation procedures must be performed by qualified personnel with full knowledge of all applicable electrical and plumbing codes. Failure could result in property damage and personal injury.



### **WARNING: ELECTRIC SHOCK HAZARD**

Brewer must be properly grounded to prevent possible shock hazard. DO NOT assume a plumbing line will provide such a ground. Electrical shock will cause death or serious injury.



### **WARNING: BURN HAZARD**

This appliance dispenses very hot liquid. Serious bodily injury from scalding can occur from contact with dispensed liquids.

This appliance is intended for commercial use only.

This appliance is intended for use to brew beverage products for human consumption. No other use is recommended or authorized by the manufacturer or its agents.

This appliance is intended for use in commercial establishments, where all operators are familiar with the appliance use, limitations and associated hazards. Operating instructions and warnings must be read and understood by all operators and users.

Except as noted, this piece of equipment is made in the USA and has American sizes on hardware. All metric conversions are approximate and can vary in size.

The following trouble shooting, component views and parts lists are included for general reference, and are intended for use by qualified service personnel.

This manual should be considered a permanent part of this appliance. The manual must remain with the appliance if it is sold or moved to another location.



### **CAUTION: EQUIPMENT DAMAGE**

DO NOT plug in or energize this appliance until all *Installation Instructions* are read and followed. Damage to the Brewer will occur if these instructions are not followed.



### **CAUTION: BURN HAZARD**

Exposed surfaces of the appliance, brew chamber and Airpot may be HOT to the touch, and can cause serious burns.

## AGENCY LISTING INFORMATION

This brewer is  and  listed under UL file E9253.

This brewer meets  Standard 4 only when installed, operated and maintained in accordance with the enclosed instructions.

Models as designated on page 1 meet  requirements.



## INSTALLATION INSTRUCTIONS

### READ THIS CAREFULLY BEFORE STARTING THE INSTALLATION



#### **CAUTION: EQUIPMENT DAMAGE**

DO NOT plug in or energize this appliance until all Installation Instructions are read and followed. Damage to the Brewer will occur if these instructions are not followed.



#### **CAUTION: UNSTABLE EQUIPMENT HAZARD**

It is very important for safety and for proper operation that the brewer is level and stable when standing in its final operating position. Provided adjustable, non-skid legs must be installed at each corner of the unit. Failure to do so will result in movement of the brewer which can cause personal injury and/or damage to brewer.

#### **IMPORTANT:**

This equipment must be installed to comply with all applicable federal, state and local plumbing codes and ordinances.

**NOTE:** Water supply inlet line must meet certain minimum criteria to insure successful operation of the brewer. Bloomfield recommends 1/4" copper tubing for installation of less than 25 feet and 3/8" for more than 25 feet from a 1/2" water supply line.

Unpack the unit. Inspect all components for completeness and condition. Ensure that all packing materials have been removed from the unit.

Verify that the Spray Head Gasket and Spray Disk are properly installed.

#### **LEVELING THE UNIT**

Verify that an adjustable leg is installed at each corner of the brewer, and that a rubber foot is installed on each leg.

Set Brewer in its operating location. Level the Brewer. A spirit level should be placed on the top of the unit, at the edge, as a guide when making level adjustments.

Level the unit from left to right and front to back by turning the adjustable feet. Be sure all four feet touch the counter to prevent tipping.

#### **PLUMBER'S INSTALLATION INSTRUCTIONS (MODEL 8773 BREWERS ONLY)**

Brewer should be connected to a **POTABLE WATER, COLD WATER** line. Flush water line before connecting to Brewer.

DO NOT use a saddle valve with a self-piercing tap for the water line connection. Such a tap can become restricted by waterline debris. For systems that must use a saddle tap, shut off the main water supply and drill a 3/16" (minimum) tap for the saddle connection, in order to insure an ample water supply. Remember to flush the line prior to installing the saddle.

The brewer must be installed on a water line with average pressure between 20 PSI and 90 PSI. If your water pressure exceeds 90 PSI at anytime, a pressure regulator must be installed in the water supply line to limit the pressure to not more than 90 PSI in order to avoid damage to lines and solenoid.

A water shut-off valve should be installed on the incoming water line in a convenient location (Use a low restriction type valve, such as a 1/4-turn ball valve, to avoid loss of water flow thru the valve.

NSF requires that the brewer be able to be moved for cleaning underneath. A flex line or loops of copper tubing will satisfy this requirement. See Fig. 2 at right.

## INSTALLATION INSTRUCTIONS (continued)

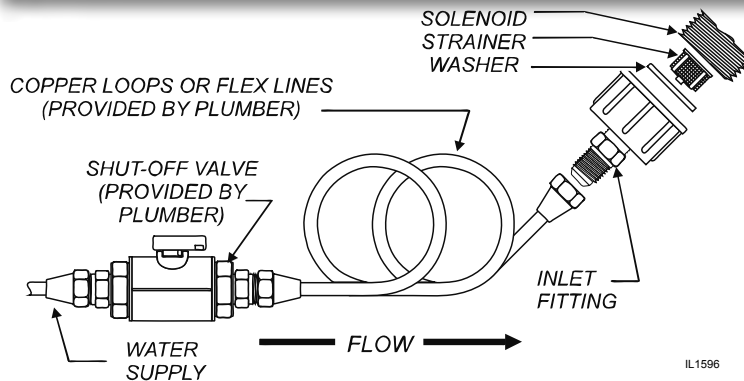

Fig. 2 Water Supply Installation - New-Style Brewers

In some areas, local codes require a backflow preventer (check valve) to be installed on the inlet water line. If a backflow preventer is used, you must install a **water hammer arrester** in the incoming line, between the backflow preventer and the brewer inlet, as far away from the brewer as space will allow. This will relieve the excessive back pressures that can cause faucet leaks and solenoid malfunctions.

### ELECTRICIAN'S INSTALLATION INSTRUCTIONS

REFER TO ELECTRICAL SPECIFICATIONS - Page 1  
Check the nameplate to determine correct electrical service required for the Brewer to be installed.

**IMPORTANT:** Before connecting to electricity, make sure automatic brewers are connected to the water supply.

**Domestic models 8773 & 8774** are equipped with a cord and plug. They require a 115 - 125 volt 15 amp circuit (50/60 Hz, 2 wire plus ground, with NEMA 5-15R receptacle).

**Export models 8773 & 8774** are equipped with a cord and plug. Refer to page 1 for circuit voltage requirements.

## **WARNING:** SHOCK HAZARD

Brewer must be properly grounded to prevent possible shock hazard. **DO NOT** assume a plumbing line will provide such a ground. Electrical shock will cause death or serious injury.

### IMPORTANT:

Do not connect brewer to electrical power until the tank is filled with water. Pour water into the pour-over opening until water flows from the brew head.

### IMPORTANT:

Supply power must match nameplate for voltage and phase. Connecting to the wrong voltage will damage the brewer or result in decreased performance. Such damage is not covered by warranty.

### IMPORTANT:

The ground prong of the plug is part of a system designed to protect you from electrical shock in the event of internal damage. Never cut off the ground prong nor twist a blade to fit an existing receptacle. Contact a licensed electrician to install the proper circuit and receptacle.

## OPERATION

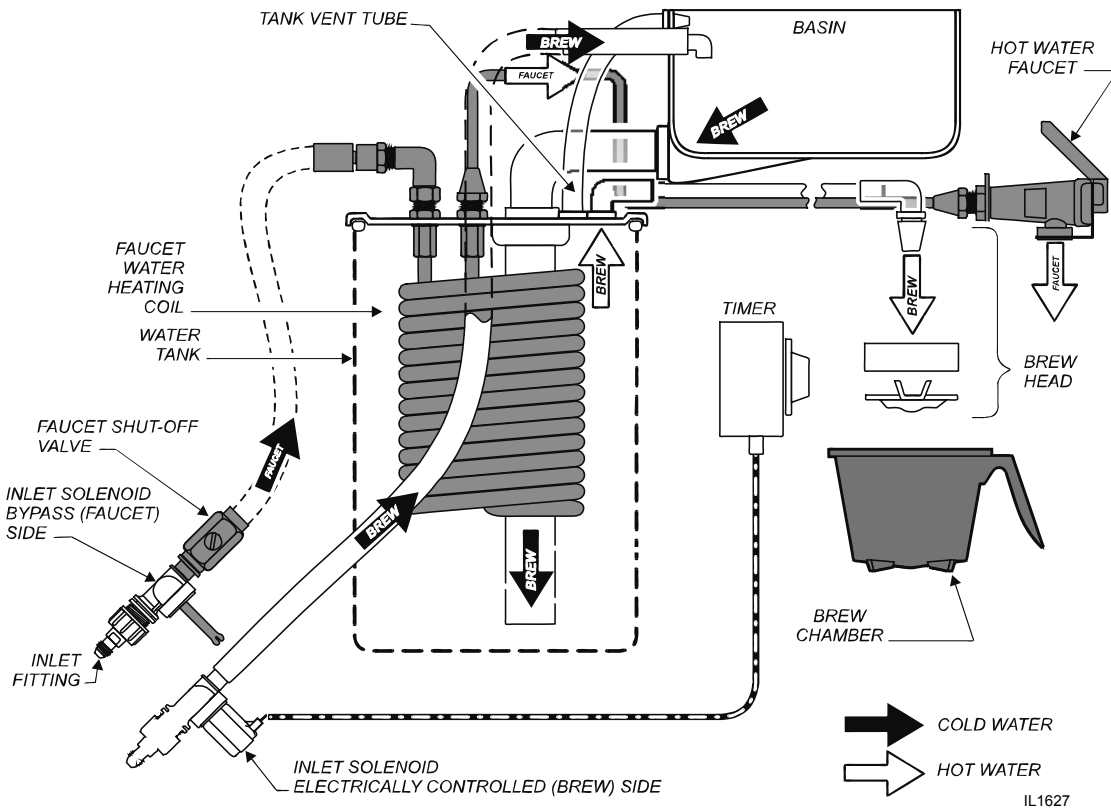

Fig. 3 Model 8773 Operation Diagram

### IMPORTANT:

Tank must be full of water before connecting brewer to electrical power. Heating elements will be damaged if allowed to operate without being fully submerged in water. Damage caused by operating the brewer without water in the tank is **NOT COVERED BY WARRANTY**.

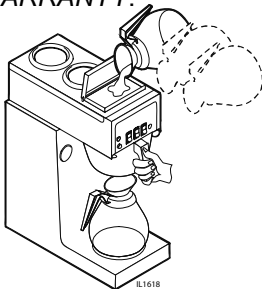

Fig. 4 Fill the Tank

### A. START-UP

For initial start-up, or if the brewer has not been used for an extended period of time:

Be sure spray disk and brew gasket are properly installed in the brew head.

For automatic brewers, be sure the water supply is properly connected and the water supply valve is turned **ON**.

**BEFORE** plugging the brewer into a receptacle, or otherwise connecting brewer to electrical power **THE WATER TANK MUST BE FILLED**. Place an empty container under the brew head. Lift the pour-over cover then pour three decanters of warm tap water into the pour-over opening. Water will begin to flow from the brew head. When all water flow stops, empty the container.

Once the tank is full of water, connect the brewer to electrical power. Press the tank heater switch to **ON**. The heating elements will begin heating the water in the tank. When the water has reached the proper temperature, the "READY TO BREW" light will glow.



## OPERATION (continued)

### WATER HEATER

Water temperature is sensed by a thermobulb inserted into the water tank. This temperature signal is fed to the thermostat, which controls line power to the heating element.

The setpoint temperature is adjustable at the thermostat.

The element is protected from over-temperature by a hi-limit thermostat.

To save energy, press the TANK HEAT switch to *OFF* if no brew is expected for an extended period.

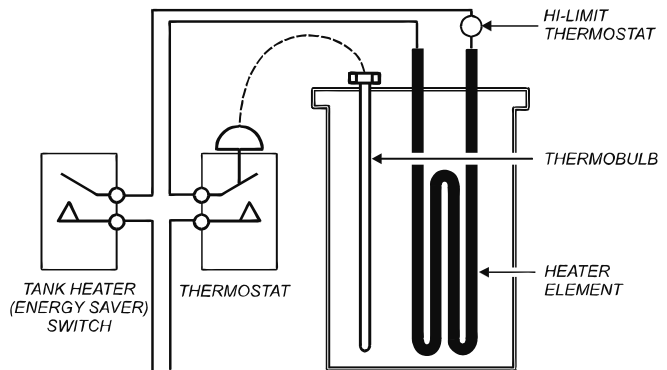
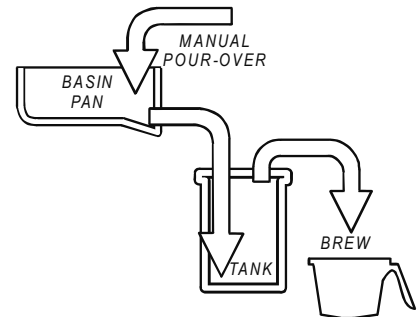

Fig. 5 Heat Control Diagram

### WATER FLOW

#### POUR-OVER FEATURE (8773 & 8774)

Pouring any amount of cold water into the pour-over opening and into the basin pan forces an identical amount of hot water out of the tank and through the spray head into the brew chamber.



#### AUTOMATIC OPERATION (8773 only)

Pressing BREW button energizes the solenoid valve, allowing water from an external water supply to flow into the basin pan and then into the hot water tank. This forces an identical amount of hot water out of the tank and through the spray head into the brew chamber.

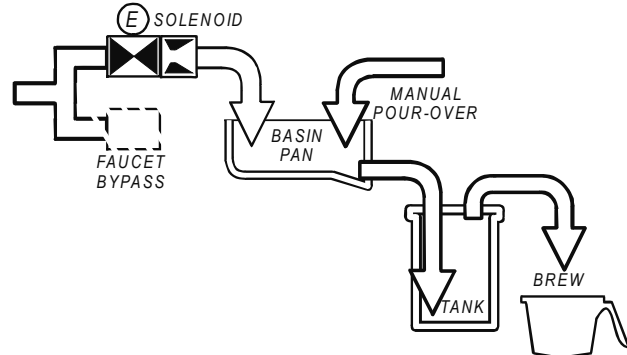

The solenoid uses a flow control device so that flow is consistent between 20 p.s.i. and 90 p.s.i.

Length of time the solenoid is open is controlled by the timer.

#### HOT WATER FAUCET (8773 only)

The faucet water coil is submerged in the hot water tank and draws heat from the brew water. Water going to the water coil is not controlled by the solenoid valve.

Hot water is provided at the faucet, at supply water pressure, any time the faucet shut-off valve is *OPEN*.

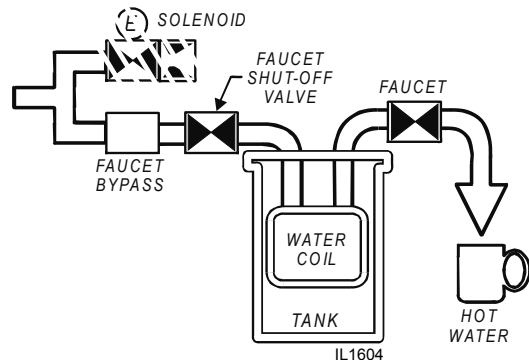

Fig. 6 Water Flow Diagram

## BREWING COFFEE



### CAUTION: BURN HAZARD

Exposed surfaces of the brewer, brew chamber and airpot may be **HOT** to the touch, and can cause serious burns.



### CAUTION: BURN HAZARD

To avoid splashing or overflowing hot liquids, **ALWAYS** place an empty airpot under the brew chamber before starting the brew cycle. Failure to comply can cause serious burns.



### CAUTION: BURN HAZARD

After a brew cycle, brew chamber contents are **HOT**. Remove the brew chamber and dispose of used grounds with care. Failure to comply can cause serious burns.

### NOTE:

Water for the hot water faucet is heated in a coil inside of the water tank. Use of the faucet will not affect the volume of water delivered for a brew. However, overuse of the faucet during a brew may lower the temperature of the brew water. Draw no more than one (1) cup of water at a time.

### A. PREPARATION

Place one (1) genuine Bloomfield paper filter in the brew chamber. Add a pre-measured amount of fresh coffee grounds. Gently shake the brew chamber to level the bed of grounds. Slide the brew chamber into place under the brew head.

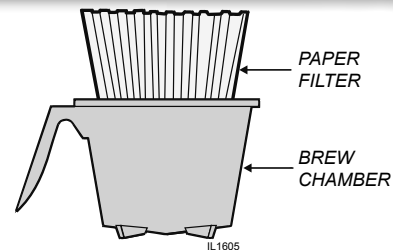

Fig. 7 Brew Chamber

### B. POUR-OVER OPERATION

**NOTE:** Any Integrity™ brewer can be used in the pour-over mode. Press the TANK HEATER switch to ON. Wait until the “READY TO BREW” light is lit.

Place the appropriate *EMPTY* airpot in place under the brew chamber.

Fill an airpot *identical to the one being used*, with tap water. Lift the pour-over cover and pour the entire contents of the airpot into the pour-over opening, which will fill the basin.

Water from the basin will displace a like amount of heated water from the tank. The hot water will be forced into the brew head where it will spray over the bed of grounds. Freshly brewed coffee will begin to fill the container under the brew chamber. When the flow and all dripping stops, the coffee is ready to serve.

Discard the contents of the brew chamber. Rinse the brew chamber in a sink. When the “READY TO BREW” light glows, the brewer is ready for another brew cycle.

### C. AUTOMATIC OPERATION (8773 only)

Press the TANK HEATER switch to ON. Wait until the “READY TO BREW” light is lit.

Place the appropriate *EMPTY* airpot in place under the brew chamber.

Press the “BREW” switch. The solenoid will open for an amount of time determined by the timer setting, admitting a measured quantity of water into the basin.

Water from the basin will displace a like amount of heated water from the tank. The hot water will be forced into the brew head where it will spray over the bed of grounds. Freshly brewed coffee will begin to fill the container under the brew chamber. When the flow and all dripping stops, the coffee is ready to serve.

Discard the contents of the brew chamber and rinse it in a sink. When the “READY TO BREW” light glows, the brewer is ready for another brew cycle.

## CLEANING INSTRUCTIONS

### PROCEDURE: Clean Coffee Brewer

**PRECAUTIONS:** Disconnect brewer from electric power.  
Allow brewer to cool.

**FREQUENCY:** Daily

**TOOLS:** Mild Detergent, Clean Soft Cloth or Sponge  
Bristle Brush, Bottle Brush

1. Disconnect brewer from electric power.  
Allow brewer to cool before cleaning.
2. Remove airpot.
3. Remove and empty brew chamber.
4. Remove the spray disk from the brew head (See figure 8):  
Press up on the spray disk ears, then turn the disk to the left to unlatch. Remove the gasket from inside the brew head.
5. Wipe inside of brew head and area around the brew head with a soft clean cloth or sponge moistened with clean water.
6. Wash the spray disk in a sink using warm water and a mild detergent. A bristle brush may be used to clear clogged spray holes. Rinse the spray disk with clean water and allow to air dry.
7. Wash the brew chamber in a sink using warm water and a mild detergent. A bristle brush may be used to clean the inside. Rinse with clean water and allow to air dry.
8. Wipe the exterior of the brewer with a soft clean cloth or sponge moistened with clean water.
10. Reinstall the gasket *INSIDE* the brew head, then reinstall the spray disk.
11. Reinstall the brew chamber.
12. DO NOT submerge airpots in water. Clean airpots by filling with warm soapy water. Scrub the inside with a bottle brush. Empty and rinse with clean water. Wipe the exterior with a soft clean cloth or sponge moistened with clean water. Invert and allow to air dry.

Procedure is complete



### CAUTION: BURN HAZARD

Brewing and serving temperatures of coffee are extremely hot.  
Hot coffee will cause serious skin burns.



### CAUTION: SHOCK HAZARD

Do not submerge or immerse brewer in water.

### IMPORTANT:

DO NOT use steel wool, sharp objects, or caustic, abrasive or chlorinated cleansers to clean the brewer, airpots.

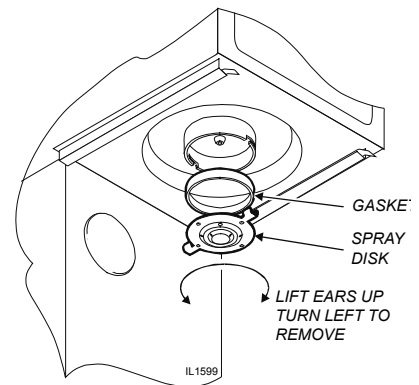

Fig. 8 Cleaning

## TROUBLESHOOTING SUGGESTIONS

SYMPTOM	POSSIBLE CAUSE	SUGGESTED REMEDY
Water won't heat (be sure TANK HEAT switch is ON)	Brewer unplugged or circuit breaker tripped	Check power supply cord Check / reset circuit breaker
	Thermostat set too low	Set for desired temperature
	Hi-Limit thermostat tripped	Allow to cool, Reset hi-limit (8786, 8788)
	Damaged internal component or wiring	Examine wiring & connectors, thermostat and heating element, Repair/replace as needed
	Pour-over - no water or too little water added at startup	Be sure to add sufficient water
Coffee level low (pour-over)	Not enough water poured in	Increase water amount
	Too much coffee grounds	Adjust amount of grounds
Coffee level too high or low (automatic)	Timer out of adjustment	Adjust timer
Brew chamber overflows	Too many filter papers or wrong filter paper	Use one (1) genuine Bloomfield filter per brew
	Brew chamber dispense hole plugged	Thoroughly clean brew chamber
	Too much coffee or too fine a grind	Adjust coffee amount and grind
Sprays water from brew head	Spray gasket improperly installed	Check/reinstall gasket on INSIDE of brew head
	Spray disk plugged	Clean spray disk
No brew (automatic)	Water supply OFF	Turn water supply ON
	Solenoid strainer plugged	Clean strainer
	Water filter (if used) plugged	Replace filter element
	Bad BREW switch	Replace switch
	Damaged internal component or wiring	Examine wiring & connectors, brew switch and solenoid Repair/replace as needed
No flow from hot water faucet	Faucet valve turned OFF	Turn faucet valve ON
	Faucet plugged	Disassemble faucet, clean
Poor coffee quality	Water not hot enough or too hot	Adjust water temp 195-205°F
	Spray disk not installed	Properly installed spray disk and gasket
	Keep brewer, airpots and servers clean. Install a taste and odor filter in water supply, and replace cartridges regularly. Use a quality coffee with a consistent roast. Use proper grind and amount of coffee per brew.	

## SERVICING INSTRUCTIONS

### ACCESS PANELS

#### TOP PANEL:

Remove top panel to access hot water tank, thermostat, heating elements, brew circuit tubing, faucet valve and piping.

Top panel is held by two screws at the rear and a retaining lip at the front.

#### FRONT PANEL:

Remove front panel to access timer .

Front panel is held by a screws through the bottom panel and a retaining lip at the top.

#### SOLENOID DOOR:

Remove solenoid door to access solenoid and plumbing connections.

Solenoid door is held by two screws and a retaining lip.



### CAUTION: SHOCK HAZARD

Opening access panels or removing warmer plates on this brew may expose uninsulated electrical components. Disconnect brewer from electrical power before removing any panel or warmer plate.

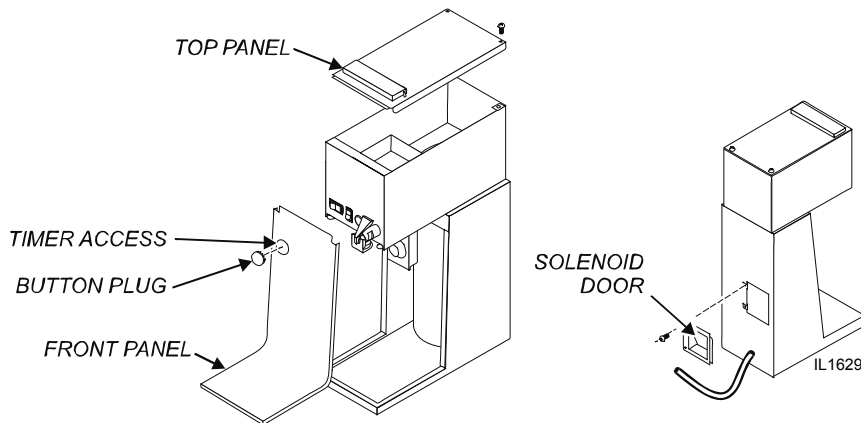

Fig. 9 Access Panels

**SERVICING INSTRUCTIONS (continued)**



**CAUTION:  
SHOCK HAZARD**

These procedures involve exposed electrical circuits. These procedures are to be performed by qualified technical personnel only.

**NOTE:**

Optimum brewing temperature range is 195°F to 205°F (90°C to 96°C).

**IMPORTANT:**

A mechanical thermostat will maintain temperature within ±5°F. To prevent boiling water in the brewer, thermostat should be adjusted to a maximum temperature equal to the local boiling temperature minus 5°F.

NOTE: 1/8 turn = approximately 10°F (5.6°C).

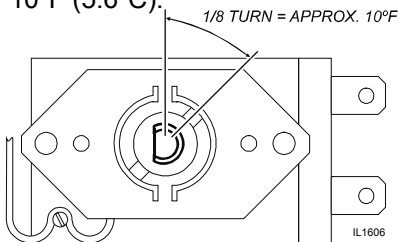

Fig. 11 Adjust Thermostat

**TEMPERATURE ADJUSTMENT**

Unplug power cord or turn circuit breaker OFF. Remove top panel.

Pull vent tube out of tank lid and insert a thermometer of known accuracy in vent hole. Reconnect brewer to electrical power.

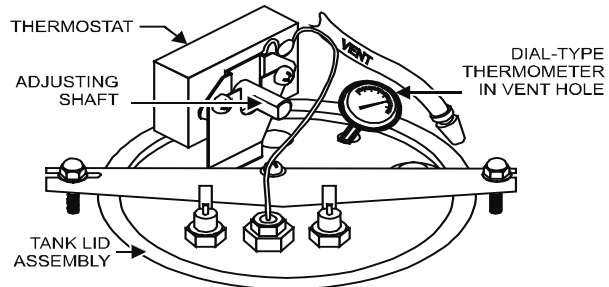

Fig. 10 Checking and Adjusting Brew Temperature

brewer and pour one decanter (64 oz.) of cold water into pour-over opening. When READY TO BREW light comes on, read temperature displayed on thermometer.

Adjust thermostat by turning shaft; clockwise increases temperature. 1/8 turn = approximately 10°F. Refer to Table 1 below for proper brewing temperature based on altitude.

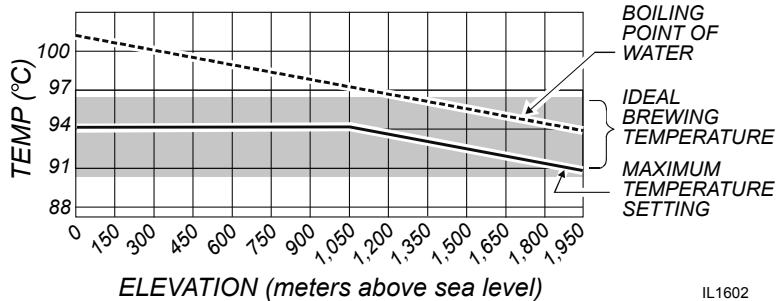
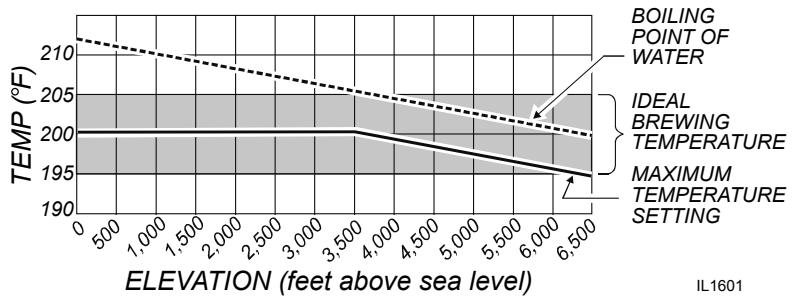

Table 1 Boiling Temperature by Altitude

Upon completion, remove thermometer and reinstall vent tube.

## SERVICING INSTRUCTIONS (continued)

### TIMER ADJUSTMENT (AUTOMATIC BREWERS ONLY)

The amount of water dispensed automatically during a brew cycle is controlled by the timer.

Place empty decanter under brew chamber. Press BREW button. Brewer should dispense one decanter of water. To adjust amount:

Remove brew chamber and button plug. Adjust knob on timer; clockwise increases time. Run several cycles to check amount of water delivered. Replace button plug.

### REMOVE TANK LID ASSEMBLY

Unplug brewer or turn circuit breaker *OFF*. Turn *OFF* water supply. Remove top panel. Pull vent tube and inlet elbow out of basin pan.

Pull water inlet tube out of basin pan. Remove basin pan.

On models with faucet, disconnect inlet pipe at faucet shut-off valve and outlet pipe at faucet.

Disconnect all wiring from thermostat, hi-limit, and heating element.

Loosen center screw on tank hold-down bracket. Remove hold-down bracket by sliding short slotted end off of locking stud and lifting it off. Remove cover assembly by lifting it straight up.

Reassemble in reverse order.

### REPLACE THERMOSTAT

Unplug brewer or turn circuit breaker *OFF*. Turn *OFF* water supply. Remove top panel.

Disconnect all wiring from thermostat only. Loosen and free jam nut from pass-thru fitting securing temperature sensing bulb. Remove two screws holding thermostat to bracket.

Lift out thermostat, sensing bulb and thermostat gasket.

Push sensing bulb into tank lid thermowell until fitting seats. Tighten capillary lock nut only enough to ensure no water leakage. Excessive tightening is not necessary.

Reassemble in reverse order.

**IMPORTANT:** Water pressure must be between 20 p.s.i and 90 p.s.i. flowing pressure. If water pressure exceeds this value, or if water pressure varies greatly, a pressure regulator must be installed in the water supply line.

**IMPORTANT:** Before setting assembly into tank, make sure tank lid gasket is properly seated on flange of lid. **DO NOT OVER-TIGHTEN.**

**IMPORTANT:** If mounting thermostat p/n 8512-51, be sure to place a new seal washer below the fitting on the capillary line.

If replacing gray-bodied thermo with p/n 8512-51, be sure to remove tube from thermowell.

## SERVICING INSTRUCTIONS (continued)

### IMPORTANT:

When replacing heating element, also replace seal gaskets.

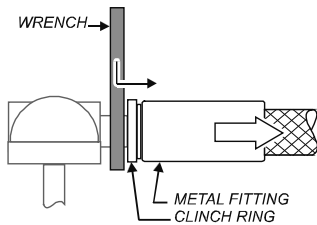
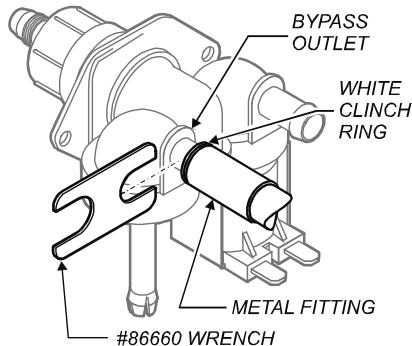

SLIDE WRENCH BETWEEN VALVE AND HOSE FITTING PRESS CLINCH RING TOWARD METAL FITTING TO RELEASE

Fig. 11 Remove Faucet Supply from Solenoid

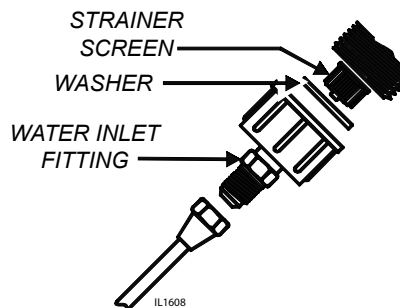

Fig. 12 Clean Strainer Screen

### REPLACE HEATING ELEMENT

Remove tank lid assembly per above.

Remove two hex nuts holding element to cover. Pull element from mounting holes.

Reassemble in reverse order.

### REPLACE SOLENOID

Symptom: Automatic brewer will not flow water; or, automatic brewer drips continuously from brew head.

**NOTE:** Wrench p/n 2C-76660 is designed to allow easy removal of the hoses from the plastic solenoid valve.

**IMPORTANT:** Shut-off water and electric supply to brewer before removing hoses or wiring.

Remove water supply flare fitting:

- Slide the 5/8" end of the wrench over the flats on the inlet fitting of the valve.
- Hold the wrench to prevent the inlet fitting from turning while installing or removing the inlet water supply flare nut.

Remove braided hose:

- Slide the 7/16" end of the wrench between the valve body and the white ring on the extreme end of the metal hose fitting.
- Pressure on the white ring toward the metal ferrule releases the clinch ring, allowing the hose to be easily slid off of the solenoid bypass outlet.
- Install hose on new valve by pressing end of hose onto bypass outlet until it is fully seated.

Disconnect wiring.

Remove two screws holding solenoid to access door.

Reassemble in reverse order.

### CLEAN SOLENOID SCREEN

Symptom: Automatic brewer will not flow water.

Unplug power cord or turn circuit breaker OFF. Turn OFF and disconnect water supply from brewer inlet fitting.

Unscrew water inlet fitting from solenoid.

Using needle-nose pliers, withdraw strainer screen from solenoid. Clean screen under faucet. A stiff bristle brush may be used if necessary.

Reinsert screen in solenoid. Be careful to maintain correct orientation. (The OPEN END of the screen goes in FIRST.)

Reassemble in reverse order.



## SERVICING INSTRUCTIONS (continued)

### REPLACE TIMER ASSEMBLY

Unplug power cord or turn circuit breaker OFF.

Remove front panel. Remove knob and three screws holding timer to bracket. Disconnect wiring to timer.

Reassemble in reverse order.

Adjust timer as described on page 13

### REPLACE HOT WATER FAUCET COIL

Symptom: Brewer drips continuously from brew head, except when faucet valve is turned OFF.

Remove tank lid assembly per above.

Remove two hex nuts hot water coil to cover. Pull coil from mounting holes.

Reassemble in reverse order.

### REPAIR HOT WATER FAUCET

Open solenoid access door. Withdraw solenoid until hot water faucet shut-off can be accessed. Turn faucet valve OFF.

Unscrew aerator cap from faucet and remove handle retaining clip. Do not let faucet body turn.

Pull bonnet assembly from faucet body.

Examine the interior of the faucet body and the surface of the seat cup. Clean out any debris in the faucet body, using a stiff bristle brush if necessary.

Examine the aerator. Clean any debris from the screen or flow straightener, using a stiff bristle brush if necessary.

Reassemble in reverse order.

### REPLACE BREW READY LIGHT or BREW BUTTON

Unplug power cord or turn circuit breaker OFF. Disconnect electric leads.

Using Switch Removal Tool (p/n 83209) or a thin screwdriver, compress mounting tabs then pry light or switch from mounting hole.

Reassemble in reverse order.

### IMPORTANT:

When replacing water faucet coil, also replace seal gaskets.

**NOTE:** Any abrasion or roughness on the flat end of the seat cup will require replacing the seat cup:

Work the seat cup out of the bonnet and off of the end of the stem.

Install a new seat cup, making sure the knob on the stem is fully inserted into the pocket of the seat cup, and the skirt of the seat cup is fully inserted into the bonnet.

## SERVICING INSTRUCTIONS (continued)



### **CAUTION:** **CHEMICAL BURN** **HAZARD**

Deliming chemicals may be caustic. Wear appropriate protective gloves and goggles during this procedure. Never siphon deliming chemicals or solutions by mouth.

This operation should only be performed by qualified and experienced service personnel.

**IMPORTANT:** DO NOT spill, splash or pour water or deliming solution into or over any internal component other than the inside of the water tank.

**IMPORTANT:** DO NOT allow any internal components to come into contact with the deliming solution. Take care to keep all internal components dry.

**NOTE:** Repeat steps 4 thru 5 as required to remove all scale and lime build-up.

### **PROCEDURE: Delime the Water Tank**

**PRECAUTIONS:** Disconnect brewer from electric power. Allow brewer to cool.

**FREQUENCY:** As required (Brewer slow to heat)

**TOOLS:** Deliming Solution  
Protective Gloves, Goggles & Apron  
Mild Detergent, Clean Soft Cloth or Sponge  
Bristle Brush, Bottle Brush  
Large Sink (or other appropriate work area)

1. Disconnect brewer from the electrical supply. For automatic brewers, turn off the water shut-off valve and disconnect the water supply line from the brewer inlet fitting.
2. Remove the tank lid assembly as described on page 13.
3. Remove the water tank from the brewer body by lifting straight up. Empty all water from the tank. Set the tank back into the brewer.
4. Mix 2 quarts of deliming solution according to the manufacturer's directions. Carefully pour the deliming solution into the water tank. Lower the lid assembly back onto the tank. Allow to sit for 30 minutes, or as directed by the manufacturer.
5. At end of soaking period, remove lid assembly from tank. Thoroughly rinse internal components of lid assembly with clear water. Using a stiff bristle brush, scrub the heating element (and faucet water coil on automatic brewers) to remove lime and calcium build-up. Rinse with clean water. Store lid assembly in a safe location .
6. Remove the tank from the brewer and empty. Using a stiff bristle brush, scrub the interior of the water tank to remove lime and calcium build-up. Rinse with clean water.

## SERVICING INSTRUCTIONS (continued)

7. Set the tank back into the brewer. Reassemble the tank lid to the water tank. Make sure the gasket is properly in place, then reinstall the hold-down strap.
8. Reinstall wiring to heating element and thermostat. Reinstall the hi-limit thermostat (if removed). For automatic brewers, reassemble piping for the faucet. Verify that all internal components are dry, then reinstall the top panel.
9. Reconnect brewer to electrical supply and, for automatic brewers, reconnect water supply.
10. Install the brew chamber without filter paper or grounds. Run at least three full brew cycles and discard all water generated.
11. Brewer is ready to use.

**NOTE:** Normally, silicone hoses do not need to be delimed. Should deliming hoses become necessary, Bloomfield recommends replacing the hoses.

# EXPLODED VIEW & PARTS LIST

## HOT WATER TANK ASSEMBLY

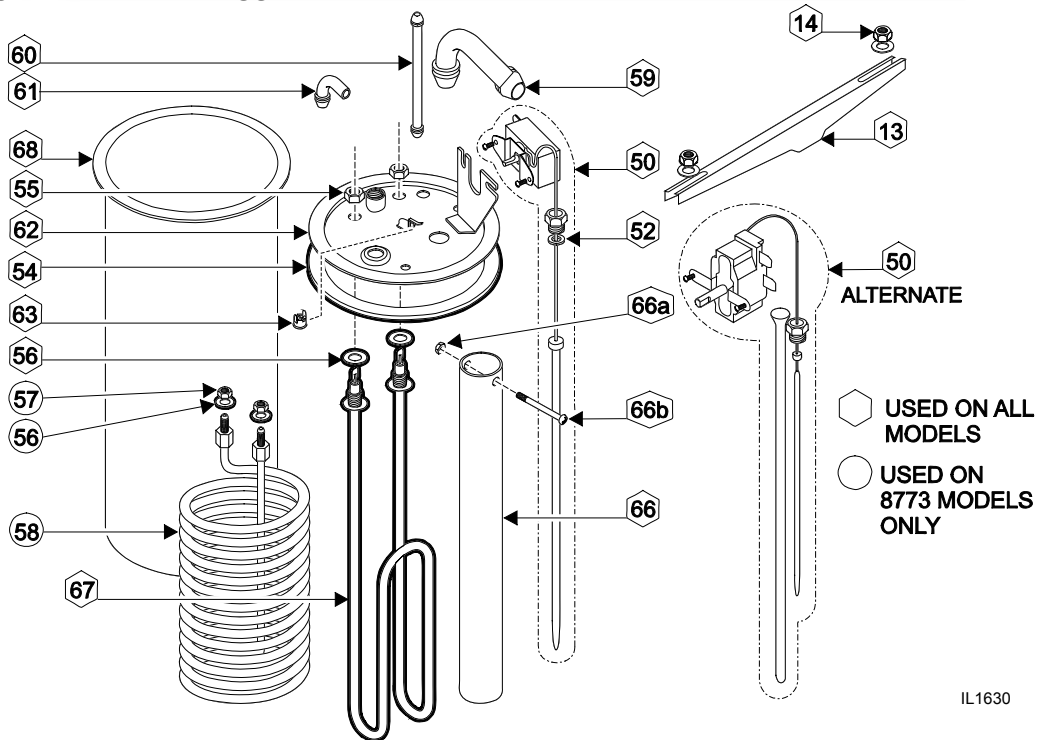

IL1630

ITEM	PART NO.	DESCRIPTION	USED ON
13	2C-70134	HOLD-DOWN STRAP	8773, 8774
14	2C-73457	NUT, HEX 8-32 KEPS	8773, 8774
50	WS-8512-51 WS-86280	THERMOSTAT (BLACK BODY - INCL. SEAL & MOUNTING SCREWS) THERMO (ALT) (GRAY BODY - INCL. TUBE & MOUNTING SCREWS)	8773, 8774
52	2C-70174	SEAL WASHER, THERMO CAP TUBE (ONLY)	8773, 8774
54	2I-70147	GASKET, TANK COVER	8773, 8774
55	2C-70151	NUT HEX 1/2-20 BRASS	8773
56	2I-70152	SEAL GASKET, ELEMENT OR WATER COIL	8773, 8774
57	2C-70151	NUT HEX 7/16-20 BRASS	
58	2N-70149	HOT WATER COIL	8773
59	2K-70101	TUBE, BASIN OUTLET/TANK INLET, SILICONE	8773, 8774
60	2V-70398	TUBE, VENT, SILICONE	8773, 8774
61	2K-70103	ELBOW, TANK OUTLET, SILICONE	8773, 8774
62	A6-70221 A6-70142	TAN COVER, PLATE ONLY, 6 HOLES TAN COVER, PLATE ONLY, 8 HOLES	8774 8773
63	2T-47499	THERMOSTAT, HI-LIMIT	8773, 8774
66	2V-70144	WATER INLET TUBE	8773, 8774
66a	2C-70146	NUT, HEX 4-40 SS	8773, 8774
66b	2C-70145	SCREW 4-40 x 1 PAN HEAD	8773, 8774
67	2N-70143UL 2N-70173UL	HEATING ELEMENT (120V, 1500W) HEATING ELEMENT (240V, 1800W)	8773, 8774 120V 8773, 8774 220/240V
68	2D-70110	TANK BODY	8773, 8774

TANK COVER ASSEMBLY	
WS-8543-300	INCLUDES: MOUNTED THERMO, HI-LIMIT & 120V 1500W HEATING ELEMENT - NO WATER COIL)
WS-8541WF-300	INCLUDES: MOUNTED THERMO, HI-LIMIT, 120V 1500W HEATING ELEMENT & HOT WATER COIL)

603 p/n 76451 8773\_8774 Owners Manual

## EXPLODED VIEW & PARTS LIST (continued)

### CABINET PLUMBING COMPONENTS

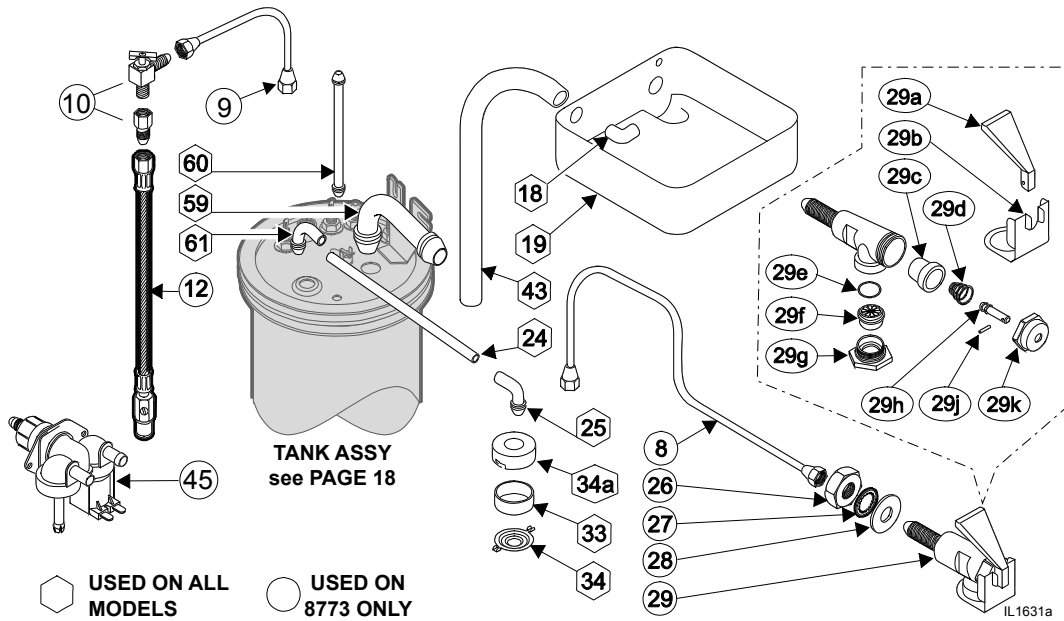

ITEM	PART NO.	DESCRIPTION	USED ON
8	2V-70104	FORMED TUBE, FAUCET OUTLET ASSEMBLY 10-7/8" LONG	8773
9	2V-70111	FORMED TUBE, FAUCET COIL INLET ASSEMBLY	8773
10	A6-70118	VALVE NEEDLE ASSEMBLY	8773
12	DD-75778	BRAIDED HOSE W/ 1/4" BALL VALVE	8773
18	2K-70096	ELBOW, BASIN INLET DIVERTER POLYPROPYLENE	8773, 8774
24	2V-70131	TUBE, BREW OUTLET, METAL 4-3/4" LONG	8773, 8774
25	2K-70130	ELBOW, SPRAYER, SILICONE	8773, 8774
26	2C-72680	LOCK NUT, HEX 7-16-20	8773
27	2C-70107	LOCK WASHER 7/16" EXT SEMS (FAUCET)	
28	2C-72681	WASHER, FLAT 15/32" x 1-1/8" x 1/16" SS	
29	WS-82556	FAUCET ASSEMBLY, PRESSURE	
33	2I-70139	GASKET, SPRAY HEAD	
34	A6-72727	SPRAY DISK, EMBOSSED	
34a	A6-70163	RETAINER, SPRAY HEAD (REQUIRES DRILL/RIVETS TO INSTALL)	
43	2V-70144	TUBE, BASIN INLET, SILICONE 10"	
45	2V-70124	VLV-SOL, 120V METAL, 75GPM	
	2E-75685	SOLENOID W/BYPASS, 120V, .75 GPM	
	2E-74570	SOLENOID W/BYPASS, 220/240V, .75 GPM	
59	2K-70101	TUBE, BASIN OUTLET/TANK INLET, SILICONE	
60	2V-70398	TUBE, VENT, SILICONE	
61	2K-70103	ELBOW, TANK OUTLET, SILICONE	
108	2D-70095	BASIN PAN	

#### FAUCET REPAIR KITS

WS-82573	HANDLE, FAUCET RED (29a)
WS-82575	SEAT CUP (29c)
WS-82576	FAUCET REPAIR KIT, INCL: HANDLE (29a), SEAT CUP (29c), SPRING (29d), STEM (29h), PIN (29j) & BONNET (29k)
WS-82682	RETAINER CLIP (29b)
WS-84804	AERATOR REPLACEMENT, INCL: O-RING (29e), DISK (29f) & CAP (29g)
WS-84870	AERATOR REPAIR KIT, INCL: O-RING (29e) & DISK (29f)

# EXPLODED VIEW & PARTS LIST (continued)

## ELECTRICAL COMPONENTS

⬡ USED ON ALL MODELS

◯ USED ON 8773 MODELS ONLY

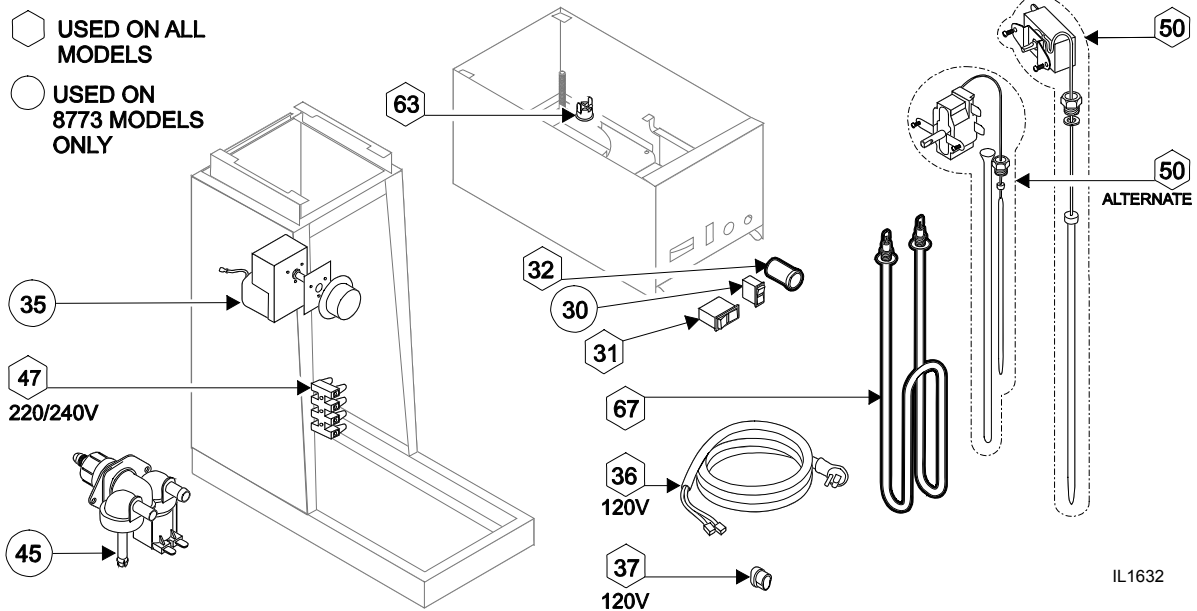

IL1632

ITEM	PART NO.	DESCRIPTION	USED ON
30	2E-70733	SWITCH, MOMENTARY, BREW START	8773
31	2E-70395	SWITCH, TANK HEAT/ENERGY SAVER	8773, 8774
32	2J-72671	INDICATOR, 120V, READY-TO-BREW	8773, 8774 (US & Canada)
	2J-70644	INDICATOR, 240V, READY-TO-BREW	8773, 8774 (Export)
35	2P-70128	TIMER, 2-MINUTE (WITH DIAL & KNOB) 120V	8773 (US & Canada)
	2P-70054	TIMER, 2-MINUTE (WITH DIAL & KNOB) 240V	8773 (Export)
36	2E-70353	POWER CORD ASSEMBLY, 120V NEMA 5-15P	8773, 8774 (US & Canada)
	DD-70647	POWER CORD ASSEMBLY, 240V (AU)	8773, 8774 (Australia)
	A6-71156	POWER CORD ASSEMBLY, 240V (EU)	8773, 8774 (Europe, Korea)
	A6-WL0139	POWER CORD ASSEMBLY, 240V (UK)	8773, 8774 (UK)
37	2K-70215	STRAIN RELIEF (US & Canada)	8773, 8774 (US & Canada)
	2K-70648	STRAIN RELIEF (AU, EU, KO, UK)	8773, 8774 (Export)
45	2E-75685	SOLENOID W/BYPASS, 120V, .75 GPM	8773 (US & Canada)
	2E-74570	SOLENOID W/BYPASS, 220/240V, .75 GPM	8773 (Export)
47	2E-70709	TERMINAL BLOCK, 4P	8774AU
50	WS-8512-51	THERMOSTAT (BLACK BODY - INCL. SEAL & MOUNTING SCREWS)	8773, 8774
	WS-86280	THERMO (ALT) (GRAY BODY - INCL. TUBE & MOUNTING SCREWS)	
63	2T-47499	THERMO, HI-LIMIT	8773, 8774
67	2N-70143UL	HEATING ELEMENT (120V, 1500W)	8773, 8774 120V
	2N-70173UL	HEATING ELEMENT (240V, 1800W)	8773, 8774 220/240V

SOLENOID REPAIR KITS	
2E-74570	SOLENOID 220/240V W/BYPASS .75GPM, COMPLETE
2E-75685	SOLENOID 120V W/BYPASS .75GPM, COMPLETE
WS-85218	INLET FITTING KIT INCLUDES: CAP (45a), FITTING (45b), GASKET (45c) & STRAINER (45d)
WS-85219	INLET STRAINER ( 45d ONLY)

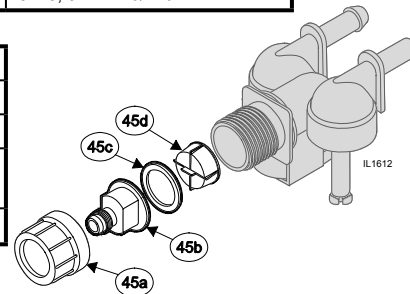

603 p/n 76451 8773\_8774 Owners Manual

## EXPLODED VIEW & PARTS LIST (continued)

### CABINET COMPONENTS

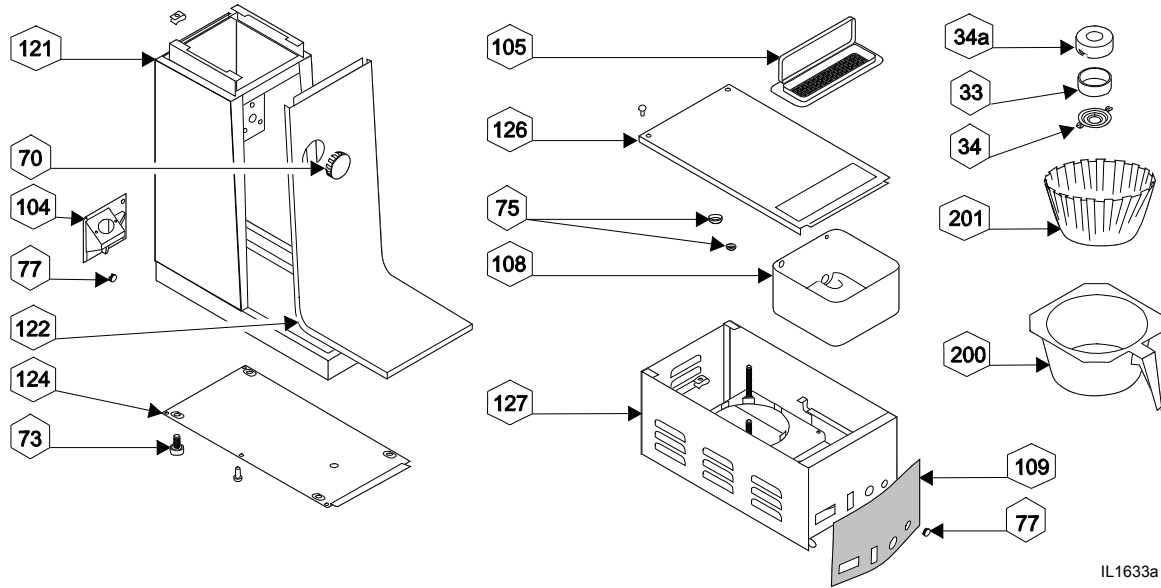

IL1633a

ITEM	PART NO.	DESCRIPTION	USED ON
33	2I-70139	GASKET, SPRAY HEAD	8773, 8774
34	A6-72727	SPRAY DISK, EMBOSSED	8773, 8774
34a	A6-70163	RETAINER, SPRAY HEAD (REQUIRES DRILL/RIVETS TO INSTALL)	8773, 8774
70	2P-70053	BUTTON PLUG, 2", METAL	8773, 8774
73	2A-71732	LEG ASSEMBLY, LEVELLING	8773, 8774
75	2K-70229	BUSHING, HEYCO (LARGE)	8773, 8774
	2K-41928	BUSHING, HEYCO (SMALL)	
77	2P-70272	BUTTON PLUG	8774
104	2Q-75089	DOOR, SOLENOID ACCESS, PLASTIC	8773, 8774
105	2F-76666	POUR OVER ASSEMBLY, PLASTIC	8773, 8774
108	2D-70399	BASIN PAN, AUTOMATIC	8773
	DD-75632	BASIN PAN, POUR-OVER	8774
109	2M-70376	LABEL, FRONT PANEL DECAL, AUTOMATIC	8773
	2M-70404	LABEL, FRONT PANEL DECAL, POUR-OVER	8774
121		BODY & BASE ASSEMBLY	8773, 8774
122		PANEL, FRONT	8773, 8774
124		BOTTOM PLATE	8773, 8774
126	WS-8542-6	BASIN COVER	8773, 8774
127	WS-8539WF-3	BASIN BODY ASSY INTEG/AIRTOP	8773, 8774
200	2D-70234	BREW CHAMBER, BLACK PLASTIC	8773, 8774
	WS-8942-6	BREW CHAMBER, BROWN PLASTIC (OPTIONAL limited to stock on hand)	
	2D-70114	BREW CHAMBER, STAINLESS W/ WIRE BASKET (OPTIONAL)	
201	WS-POF	FILTER PAPER, COFFEE (CASE OF 1000)	8773, 8774

## SERVICE KITS

### SOLENOID REPAIR KITS

- WS-85218      Inlet Fitting Kit (items 45a, 45b, 45c, 45d)
- WS-85219      Inlet Strainer (item 45d)

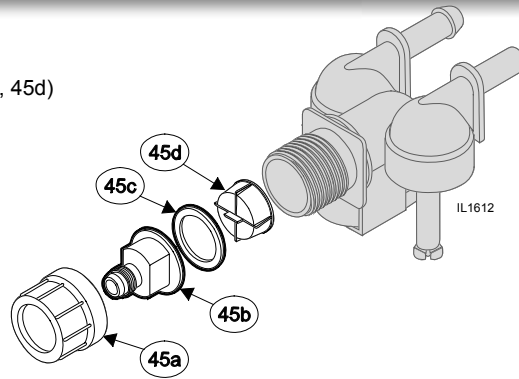

### COMPLETE SPARE TANK COVER

- WS-8541 WF-300 Spare Cover Assembly (120V, 1500W, 8773 (U.S. & Canada) With Coil - all parts mounted to cover)
- WS-8543-300 Spare Cover Assembly (120V, 1500W, 8774 (U.S. & Canada) No Coil - all parts mounted to cover)

### FAUCET REPAIR KITS

- WS-82573      Handle (item 29a)
- WS-82575      Seat Cup (item 29c)
- WS-82576      Faucet Repair Kit (Includes 29a Handle, 29c Seat Cup, 29d Spring, 29h Stem, 29j Pin & 29k Bonnet)
- WS-82682      Retainer Clip (item 29b)
- WS-84804      Aerator Replacement Kit (Includes 29e O-Ring, 29f Aerator Disk & 29g Aerator Cap)
- WS-84870      Aerator Repair Kit (Includes 29e O-Ring & 29f Aerator Disk)

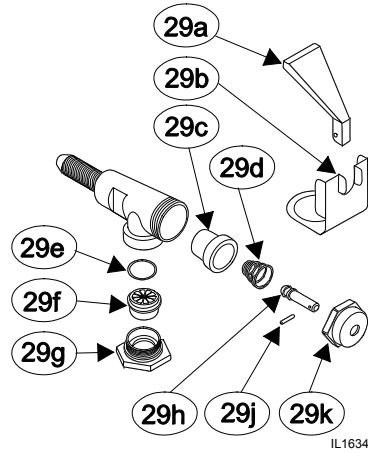

### LINE STRAINER

- 2V-73027      "Y" Strainer, 1/4" Male Flare

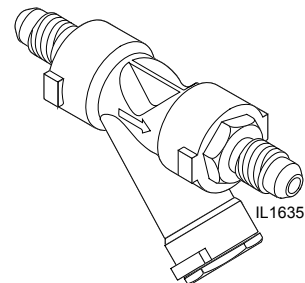



**WIRING DIAGRAMS**

**WIRING DIAGRAM  
MODEL 8773  
(U.S. & CANADA)**  
p/n 70547 issue D

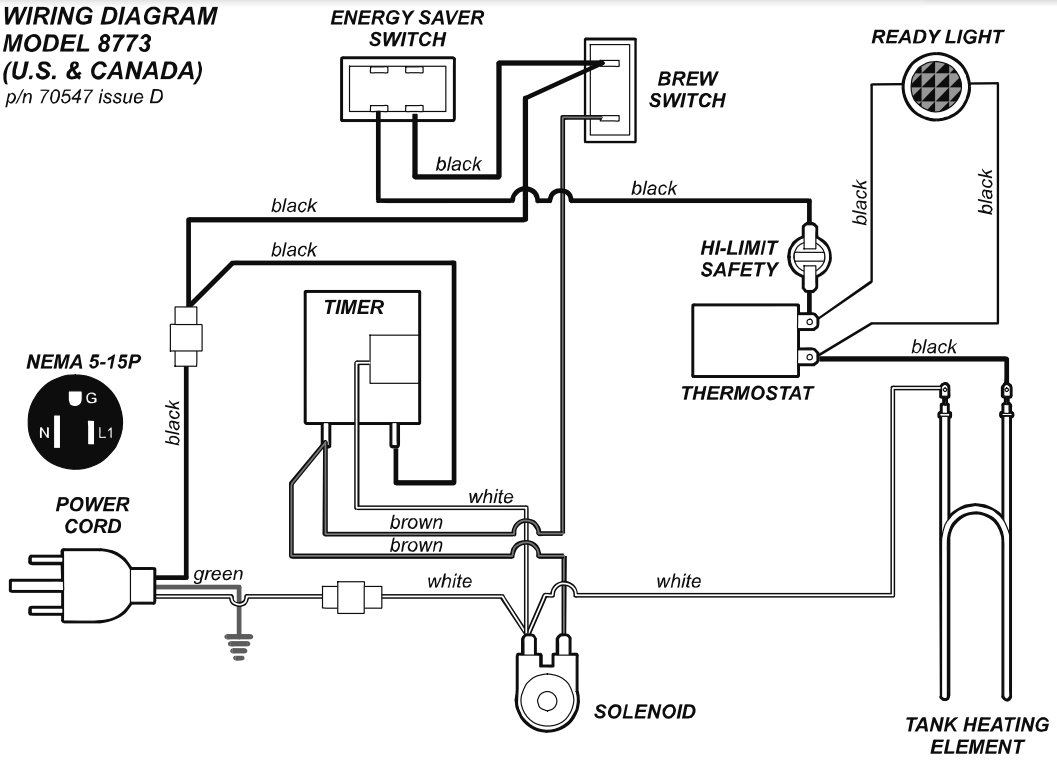

**WIRING DIAGRAM  
MODEL 8774  
(U.S. & CANADA)**  
p/n 71625 issue (-)

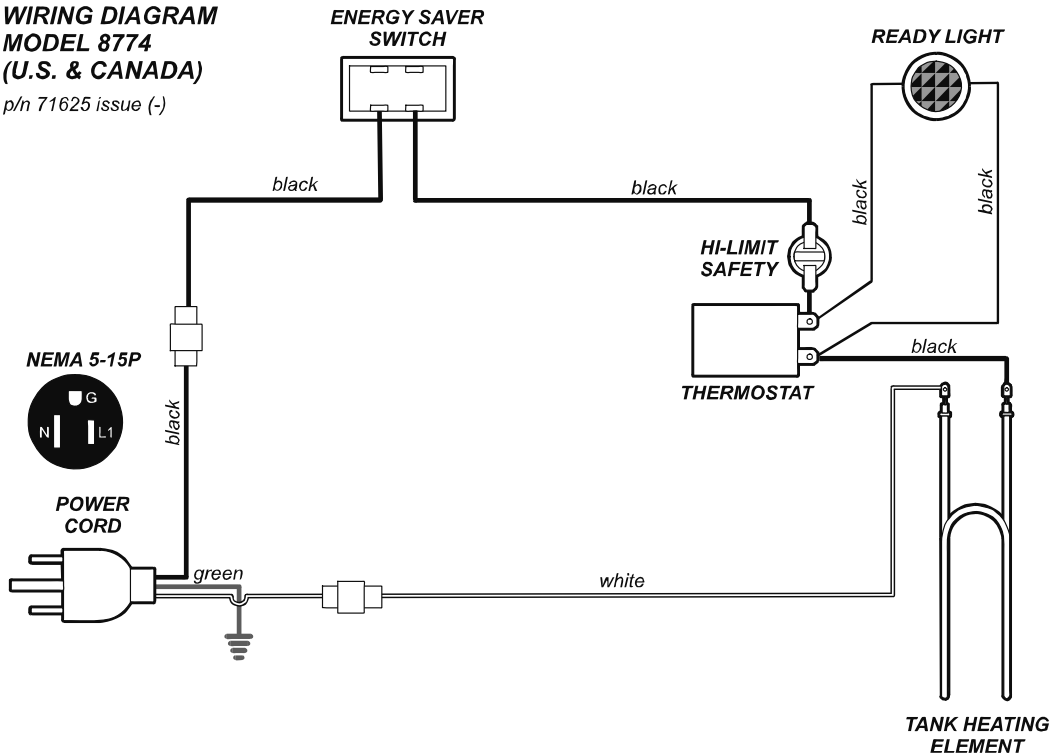

**WIRING DIAGRAMS (continued)**

**WIRING DIAGRAM  
MODELS 8773 AU  
8773 EU  
8773 UK**

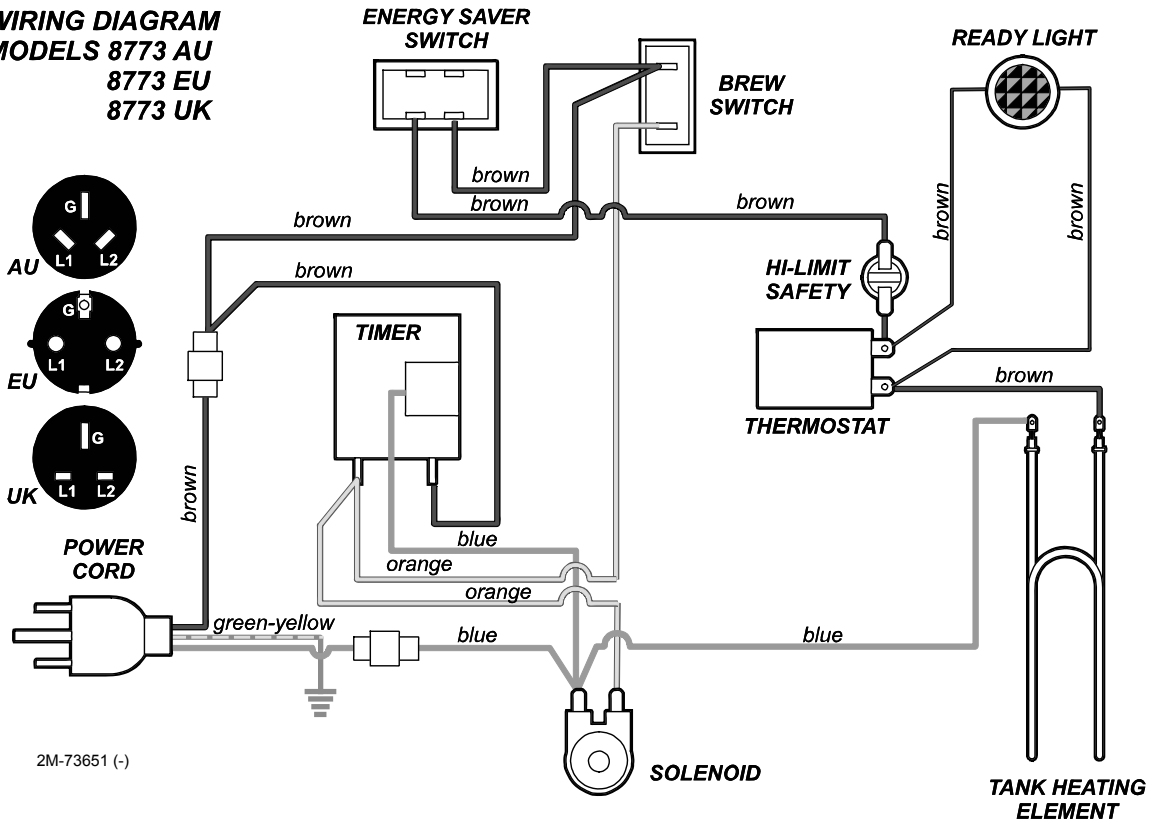

2M-73651 (-)

# WIRING DIAGRAM (continued)

**WIRING DIAGRAM  
MODEL 8774AU**  
p/n 71151 issue (-)

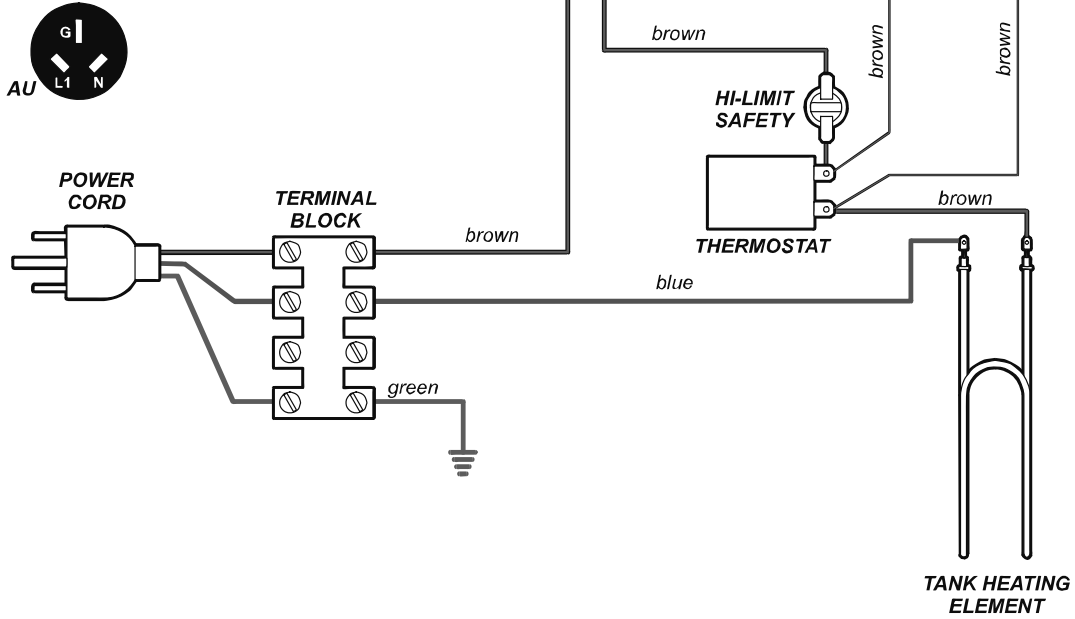

**WIRING DIAGRAM  
MODEL 8774EU  
8774UK  
8774 KO**  
p/n 73650 issue (-)

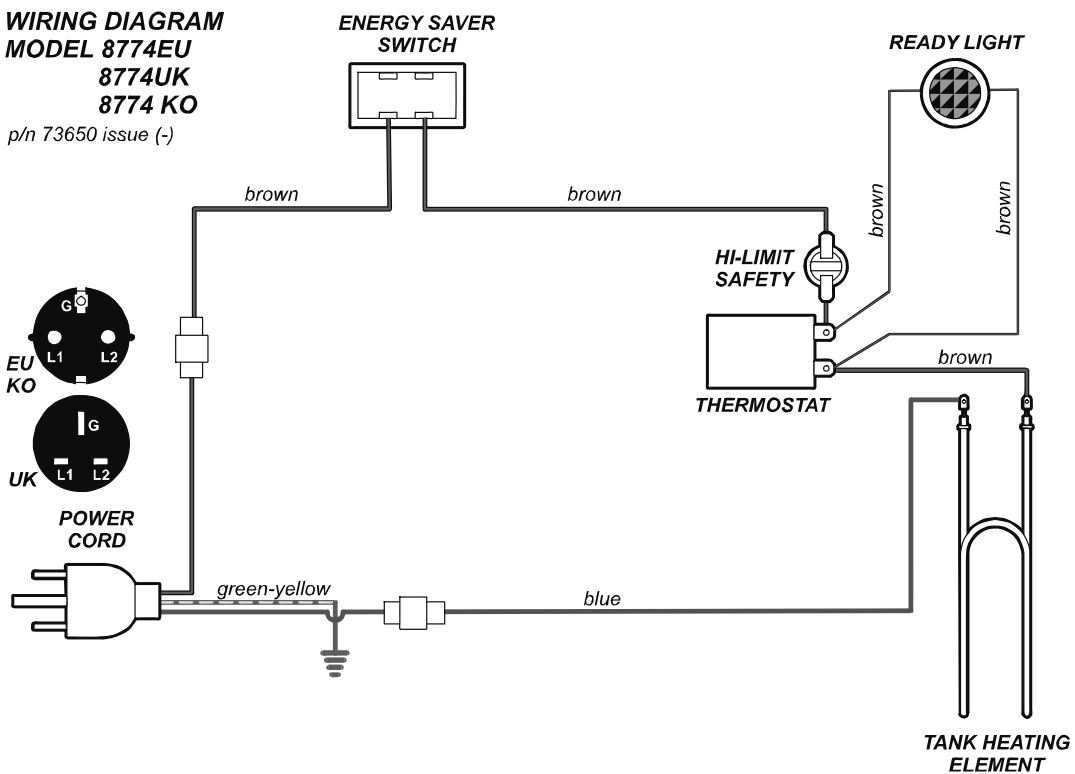

603 p/n 76451 8773\_8774 Owners Manual



Commercial Food Equipment Service Association

Wells Bloomfield proudly supports CFESA  
Commercial Food Equipment Service Association

**SERVICE TRAINING - QUALITY SERVICE**



**CUSTOMER SATISFACTION**



10 Sunnen Drive, St. Louis, MO 63143  
telephone: 314-678-6336 fax: 314-781-2714  
[www.bloomfieldworldwide.com](http://www.bloomfieldworldwide.com)