

BLOOMFIELD INDUSTRIES
10 Sunnen Drive
St. Louis, MO 63143
telephone: 314-678-6336
fax: 314-781-2714
www.wellsbloomfield.com



*Model 8783D3FM Brewer
with optional
8900-Series Decanters*

Place this chapter in the Beverage
Section of the Equipment Manual



**OWNERS MANUAL
for
3-WARMER
DECANTER
COFFEE BREWERS
WITH INDEPENDENT
HOT WATER DRAW FAUCET**

MODEL:

8783D3FM

Includes:

**Installation
Operation
Use & Care
Servicing Instructions**

**This instruction is for the
exclusive use of licensees
and employees of
McDonalds Systems, Inc.**

WARRANTY STATEMENT

All electrical equipment manufactured by WELLS BLOOMFIELD, LLC is warranted against defects in materials and workmanship for a period of one year from the date of original installation or eighteen (18) months from the date of shipment from our factory, whichever comes first, and is for the benefit of the original purchaser, except that:

- a. airpots carry a 30 day parts warranty only.
- b. dispensers; i.e., tea and coffee carry a 90 days parts warranty only, excludes decanters.

THE FOREGOING OBLIGATION IS EXPRESSLY GIVEN IN LIEU OF ANY OTHER WARRANTIES, EXPRESSED OR IMPLIED, INCLUDING ANY IMPLIED WARRANTY OF MERCHANTABILITY OR FITNESS FOR A PARTICULAR PURPOSE, WHICH ARE HEREBY EXCLUDED.

WELLS BLOOMFIELD, LLC SHALL NOT BE LIABLE FOR INDIRECT, INCIDENTAL OR CONSEQUENTIAL DAMAGES OR LOSSES FROM ANY CAUSE WHATSOEVER.

This warranty is void if it is determined that upon inspection by an Authorized Service Agency that the equipment has been modified, misused, misapplied, improperly installed, or damaged in transit or by fire, flood or act of God.

It also does not apply if the serial nameplate has been removed or unauthorized service personnel perform service. The prices charged by Bloomfield Industries for its products are based upon the limitations in this warranty. Seller's obligation under this warranty is limited to the repair of defects without charge by a Bloomfield Authorized Service Agency or one of its sub-agencies. This service will be provided on customer's premises for non-portable models. Portable models (a device with a cord and plug) must be taken or shipped to the closest Authorized Service Agency, transportation charges prepaid, for services.

In addition to restrictions contained in this warranty, specific limitations are shown below (Additional Warranty Exclusions). Bloomfield Industries Authorized Service Agencies are located in principal cities.

This warranty is valid in the United States and void elsewhere. Please consult your classified telephone directory or your food service equipment dealer; or, for information and other details concerning warranty, write to:

Service Parts Department
Wells Bloomfield, LLC

10 Sunnen Drive, St. Louis, MO 63143

Phone: (314) 678-6336...

Fax: (314) 781-2714

SERVICE POLICY AND PROCEDURE GUIDE ADDITIONAL WARRANTY EXCLUSIONS

1. Resetting of safety thermostats, circuit breakers, overload protectors, or fuse replacements unless warranted conditions are the cause.
2. All problems due to operation at voltages other than specified on equipment nameplates; conversion to correct voltage must be the customer's responsibility.
3. All problems due to electrical connections not made in accordance with electrical code requirements and wiring diagrams supplied with the equipment.
4. Replacement of items subject to normal wear, to include such items as knobs and light bulbs. Normal maintenance functions including adjustment of thermostats, microswitches, and replacement of fuses and indicating lights are not covered under warranty.
5. All problems due to inadequate water supply, such as fluctuating, or high or low water pressure.
6. All problems due to mineral/calcium deposits, or contamination from chlorides/chlorines. De-liming is considered a preventative maintenance function and is not covered by warranty.
7. Full use, care and maintenance instructions are supplied with each machine. Those miscellaneous adjustments noted are customer responsibility. Proper attention will prolong the life of the machine.
8. Travel mileage is limited to sixty (60) miles from an authorized Service Agency or one of its sub-agencies.
9. All labor shall be performed during normal working hours. Overtime premium shall be charged to the customer.
10. All genuine Bloomfield replacement parts are warranted for ninety (90) days from date of purchase on non-warranted equipment. **Any use of non-genuine Bloomfield parts completely voids any warranty.**
11. Installation, labor and job check-out are not considered warranty.
12. Charges incurred by delays, waiting time or operating restrictions that hinder the service technicians ability to perform services are not covered by warranty. This includes institutional and correctional facilities.

SHIPPING DAMAGE CLAIMS PROCEDURE

NOTE: For your protection, please note that equipment in this shipment was carefully inspected and packaged by skilled personnel before leaving the factory.

Upon acceptance of this shipment, the transportation company assumes full responsibility for its safe delivery.

IF SHIPMENT ARRIVES DAMAGED:

1. **VISIBLE LOSS OR DAMAGE:** Be certain that any visible loss or damage is noted on the freight bill or express receipt, and that the note of loss or damage is signed by the delivery person.
2. **FILE CLAIM FOR DAMAGE IMMEDIATELY:** Regardless of the extent of the damage.

3. **CONCEALED LOSS OR DAMAGE:** if damage is unnoticed until the merchandise is unpacked, notify the transportation company or carrier immediately, and file "CONCEALED DAMAGE" claim with them. This must be done within fifteen (15) days from the date the delivery was made to you. Be sure to retain the container for inspection.

Wells Bloomfield cannot assume liability for damage or loss incurred in transit. We will, however, at your request, supply you with the necessary documents to support your claim.

TABLE OF CONTENTS

WARRANTY STATEMENT	xi
SPECIFICATIONS	1
FEATURES & OPERATING CONTROLS	2
PRECAUTIONS & GENERAL INFORMATION	3
AGENCY LISTING INFORMATION	3
INSTALLATION INSTRUCTIONS	4
OPERATION	6
BREWING COFFEE	8
CLEANING INSTRUCTIONS	9
TROUBLESHOOTING SUGGESTIONS	10
SERVICING INSTRUCTIONS	11
Deliming Instructions	14
EXPLODED VIEW & PARTS LIST	18
SERVICE KITS	20
WIRING DIAGRAMS	21

Thank you for purchasing this Wells Bloomfield appliance.

Proper installation, professional operation and consistent maintenance of this appliance will ensure that it gives you the very best performance and a long, economical service life.

This manual contains the information needed to properly install this appliance, and to use, care for and maintain or repair the appliance in a manner which will ensure its optimum performance.

SPECIFICATIONS

MODEL	VOLTS	WATTS	AMPS 1 ϕ	POWER SUPPLY REQUIREMENTS
8783D3FM	220-240	3900	16.2	2 WIRE +GND Not provided

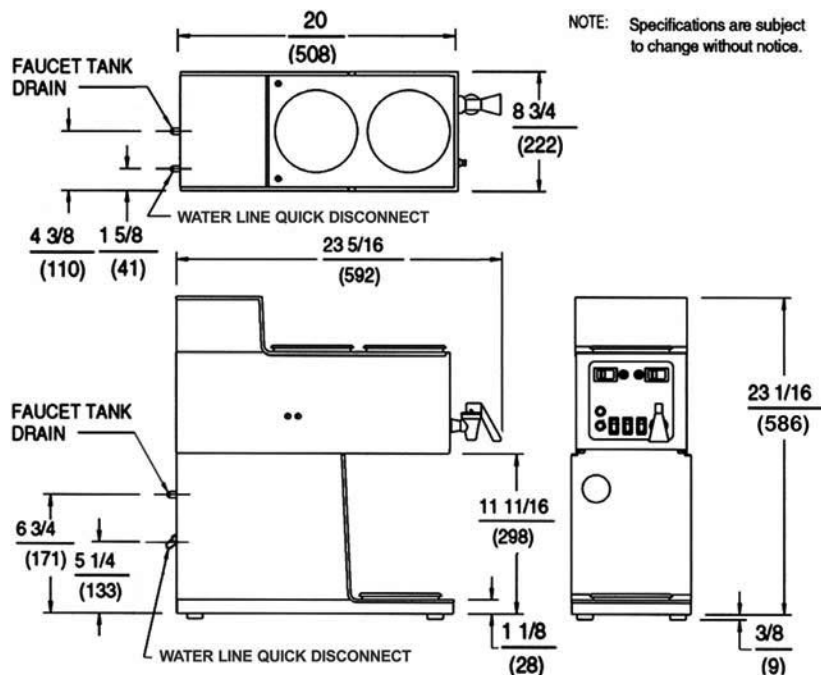

APPLICABILITY

This manual applies to the following Bloomfield product:
8783D3FM

FEATURES AND OPERATING CONTROLS

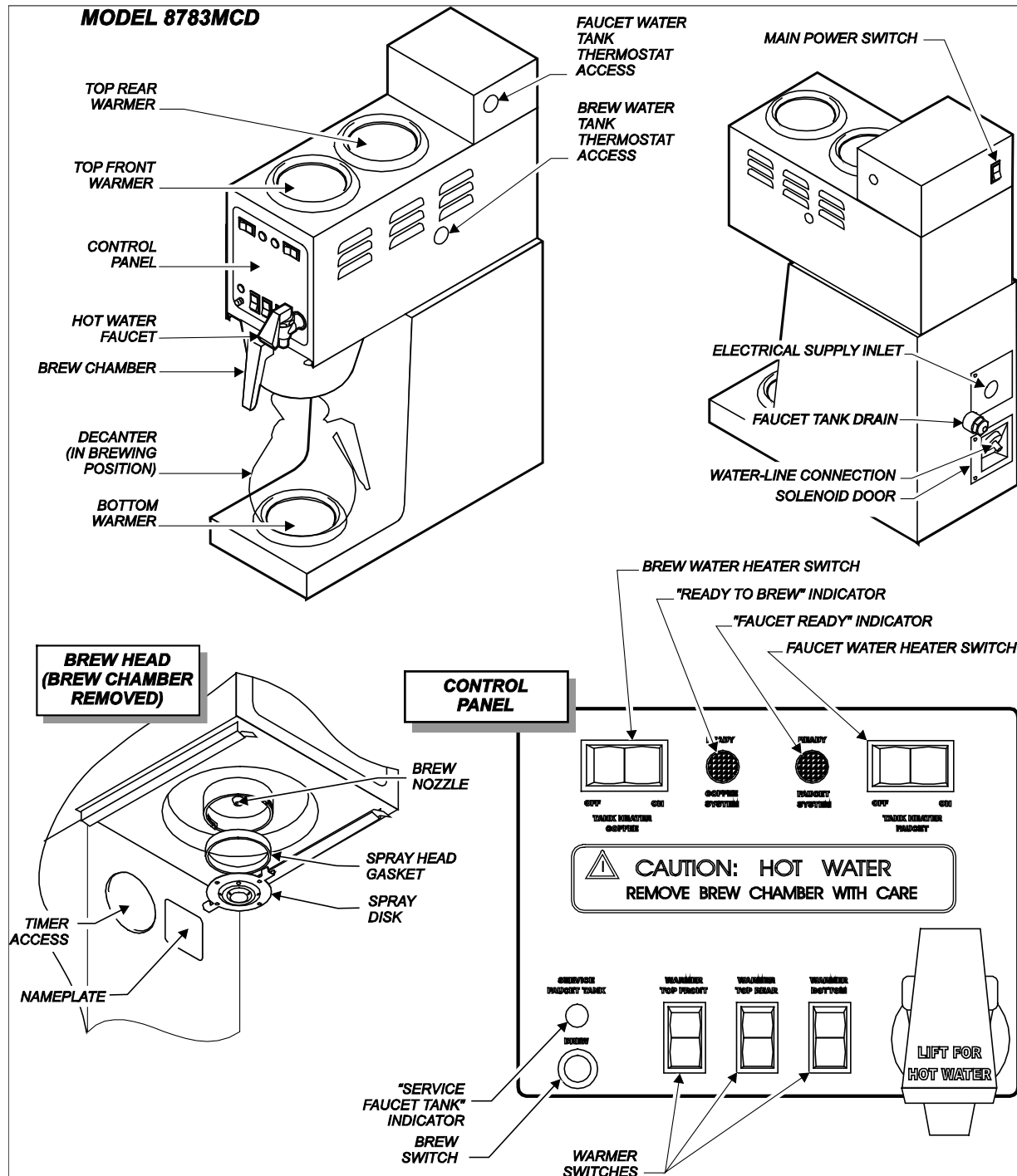

Fig. 1 Features & Operating Controls

PRECAUTIONS AND GENERAL INFORMATION



WARNING: ELECTRIC SHOCK HAZARD

All servicing requiring access to non-insulated components must be performed by qualified service personnel. Do not open any access panels which require the use of tools. Failure to heed this warning can result in electrical shock.



WARNING: INJURY HAZARD

All installation procedures must be performed by qualified personnel with full knowledge of all applicable electrical and plumbing codes. Failure could result in property damage and personal injury.



WARNING: SHOCK HAZARD

Brewer must be properly grounded to prevent possible shock hazard. DO NOT assume a plumbing line will provide such a ground. Electrical shock will cause death or serious injury.



WARNING: BURN HAZARD

This appliance dispenses very hot liquid. Serious bodily injury from scalding can occur from contact with dispensed liquids.

This appliance is intended for commercial use only.

This appliance is intended for use to brew beverage products for human consumption. No other use is recommended or authorized by the manufacturer or its agents.

This appliance is intended for use in commercial establishments, where all operators are familiar with the appliance use, limitations and associated hazards. Operating instructions and warnings must be read and understood by all operators and users.

Except as noted, this piece of equipment is made in the USA and has American sizes on hardware. All metric conversions are approximate and can vary in size.

The following trouble shooting, component views and parts lists are included for general reference, and are intended for use by qualified service personnel.

This manual should be considered a permanent part of this appliance. The manual must remain with the appliance if it is sold or moved to another location.



CAUTION: EQUIPMENT DAMAGE

DO NOT plug in or energize this appliance until all *Installation Instructions* are read and followed. Damage to the Brewer will occur if these instructions are not followed.



CAUTION: BURN HAZARD

Exposed surfaces of the appliance, brew chamber and decanter or thermal server may be HOT to the touch, and can cause serious burns.

AGENCY LISTING INFORMATION

Export versions of this brewer meet  requirements.

This brewer meets  Standard 4 only when installed, operated and maintained in accordance with the enclosed instructions.



INSTALLATION

READ THIS CAREFULLY BEFORE STARTING THE INSTALLATION

IMPORTANT:

To enable the installer to make a quality installation and to minimize installation time, the following suggestions and tests should be done before the actual unit installation is started:



CAUTION: EQUIPMENT DAMAGE

DO NOT plug in or energize this appliance until all Installation Instructions are read and followed. Damage to the Brewer will occur if these instructions are not followed.



CAUTION: UNSTABLE EQUIPMENT HAZARD

It is very important for safety and for proper operation that the brewer is level and stable when standing in its final operating position. Provided adjustable, non-skid legs must be installed at each corner of the unit. Failure to do so will result in movement of the brewer which can cause personal injury and/or damage to brewer.

NOTE: Water supply inlet line must meet certain minimum criteria to insure successful operation of the brewer. Bloomfield recommends 1/4" copper tubing for installation of less than 12 feet and 3/8" for more than 12 feet from a 1/2" water supply line.

Unpack the unit. Inspect all components for completeness and condition. Ensure that all packing materials have been removed from the unit.

Verify that the Spray Head Gasket and Spray Disk are properly installed.

LEVELING THE UNIT

Verify that an adjustable leg is installed at each corner of the brewer.

Set Brewer in its operating location. Level the Brewer. A spirit level should be placed on the top of the unit, at the edge, as a guide when making level adjustments.

Level the unit from left to right and front to back by turning the adjustable feet. Be sure all four feet touch the counter to prevent tipping.

PLUMBER'S INSTALLATION INSTRUCTIONS

Brewer should be connected to a **POTABLE WATER, COLD WATER** line. Flush water line before connecting to Brewer.

DO NOT use a saddle valve with a self-piercing tap for the water line connection. Such a tap can become restricted by waterline debris. For systems that must use a saddle tap, shut off the main water supply and drill a 3/16" (minimum) tap for the saddle connection, in order to insure an ample water supply. Remember to flush the line prior to installing the saddle.

The brewer must be installed on a water line with average pressure between 20 PSI and 90 PSI. If your water pressure exceeds 90 PSI at anytime, a pressure regulator must be installed in the water supply line to limit the pressure to not more than 90 PSI in order to avoid damage to lines and solenoid.

A water shut-off valve should be installed on the incoming water line in a convenient location (Use a low restriction type valve, such as a 1/4-turn ball valve, to avoid loss of water flow thru the valve.

A water line strainer should be installed in the supply line, between the shutoff valve and inlet fitting. Install with FLOW arrow marking on strainer body pointing toward brewer.

INSTALLATION (continued)

NSF requires that the brewer be able to be moved for cleaning underneath. Provided flex line will satisfy this requirement. See Figure 2 below.

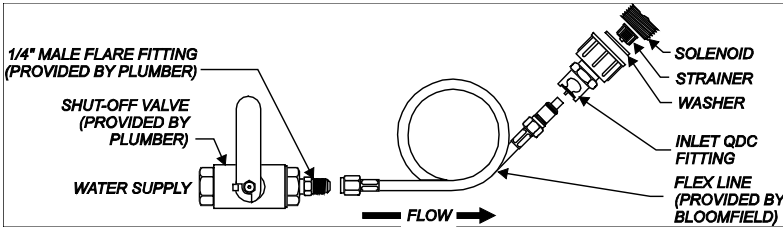

Fig. 2 Water Supply Installation

ELECTRICIAN'S INSTALLATION INSTRUCTIONS

IMPORTANT:

Do not energize this brewer until both water tanks are filled. See filling instructions, page 6

REFER TO ELECTRICAL SPECIFICATIONS - Page 1
Check the nameplate to determine correct electrical service required for the brewer to be installed.

IMPORTANT: Before connecting to electricity, make sure automatic brewers are connected to the water supply.

Model 8783D3FM requires a dedicated 220 to 240 volt 20 amp circuit (L1, L2) plus ground.

Wiring by others must be installed to the terminal block in Model 8783MCD. Wiring must be secured to the brewer with a strain relief (by others). See Figure 3a below.

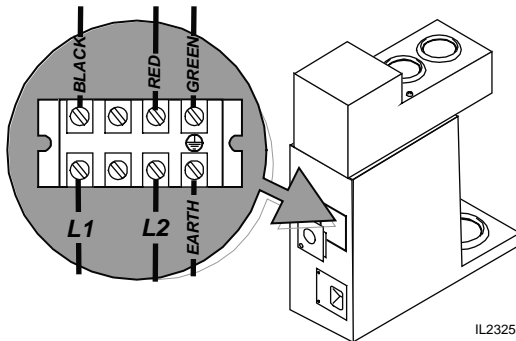

Fig. 3 Wiring Connections

NOTE: This equipment must be installed to comply with all applicable plumbing codes and ordinances.



Brewer must be properly grounded to prevent possible shock hazard. DO NOT assume a plumbing line will provide such a ground. Electrical shock will cause death or serious injury.

IMPORTANT:

Supply power must match nameplate for voltage and phase. Connecting to the wrong voltage will damage the brewer or result in decreased performance. Such damage is not covered by warranty.

IMPORTANT: Do not connect brewer to electrical power until you are ready to fill the tanks. See instructions on page 6.

IMPORTANT: This brewer requires a dedicated 20 amp single phase 220 to 240 volt AC circuit. Contact a licensed electrician to install the proper circuit.

OPERATION

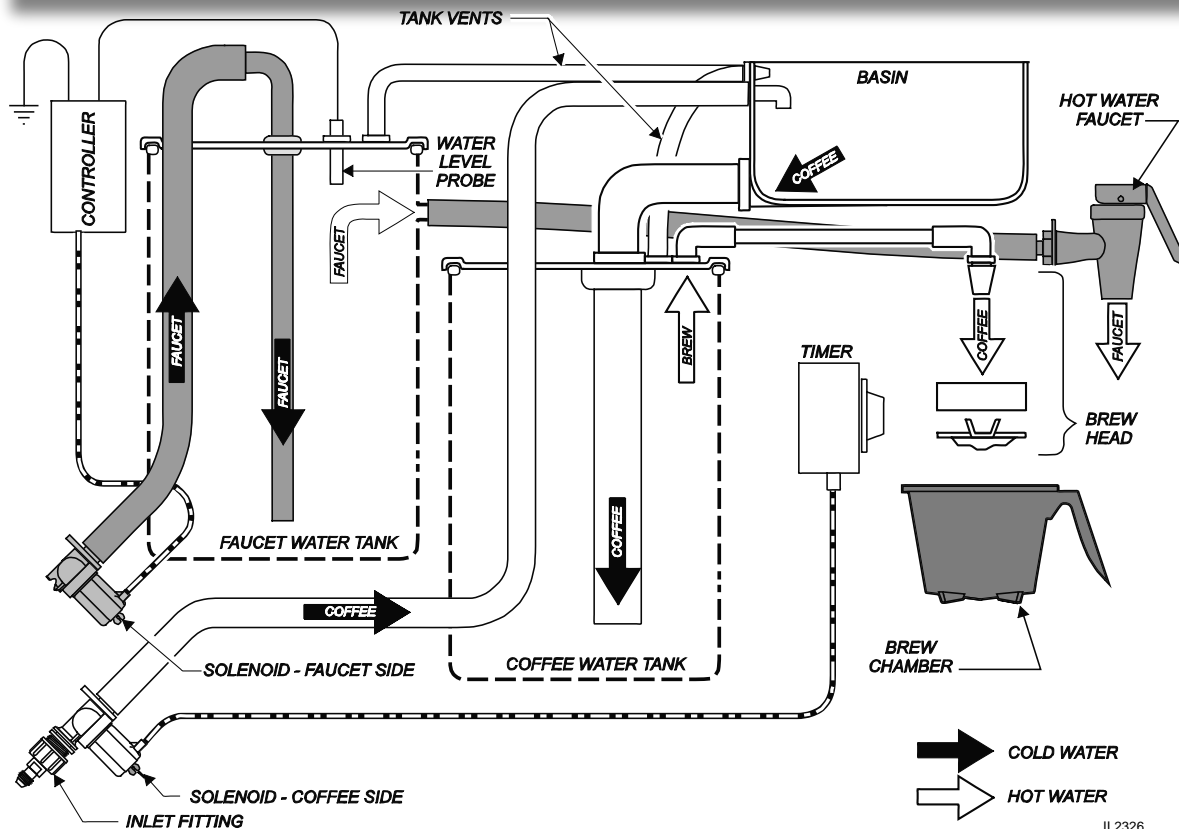

Fig. 4 Brewer Operation Diagram

IMPORTANT:

Tanks must be full of water before pressing either TANK HEATER SWITCH "ON". Heating elements will be damaged if allowed to operate without being fully submerged in water. Damage caused by operating the brewer without water in the tank is **NOT COVERED BY WARRANTY**.

If no water is detected at water level probe after two minutes, unit will shut down and the SERVICE FAUCET TANK light will glow.

A. START-UP

For initial start-up, or if the brewer has not been used for an extended period of time:

- Be sure spray disk and brew gasket are properly installed in the brew head.
- Be sure the water supply is properly connected and the water supply valve is turned ON.
- Be sure faucet water tank drain cap is securely installed.
- Be sure the WATER TANKS ARE FILLED.

IMPORTANT: Fill the water tanks before pressing heater switches ON:

1. Insert the brew chamber (empty) and place an empty decanter in place under the brew chamber. Be sure heater switches are OFF.
2. Press main power switch ON.
3. Press "BREW" button and allow brew cycle to complete. Repeat until water flows from the brew head. If SERVICE FAUCET TANK lights, press main power switch OFF, then ON to reset.
4. Place an empty container under the hot water faucet. Hold the faucet open until water flows and all air is purged.
5. Press the tank heater switches ON. The heating elements will begin heating the water in the tanks. When the water in a tank has reached the proper temperature, the associated "READY" light will glow.

OPERATION (continued)

WATER HEATER

Separate coffee brew water and faucet water heater systems are identical. Each heating element is protected from over-temperature by a manual reset hi-limit safety thermostat.

Water temperature is sensed by a thermobulb inserted into each water tank. This temperature signal is fed to the corresponding thermostat, which controls line power to that tank's heating element.

The temperature setpoint is adjustable at the thermostat.

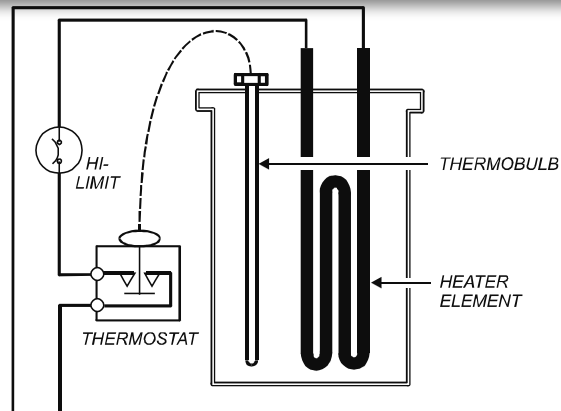

Fig. 5 Heat Control Diagram

WATER FLOW

AUTOMATIC COFFEE BREW

Pressing BREW button energizes the solenoid valve, allowing water from an external water supply to flow into the basin pan and then into the hot water tank. This forces an identical amount of hot water out of the tank and through the spray head into the brew chamber.

The solenoid uses a flow control device so that flow is consistent between 20 p.s.i. and 90 p.s.i.

Length of time the solenoid is open is controlled by the timer.

A second brew cannot be initiated until delay time (set by DELAY section of timer) is completed.

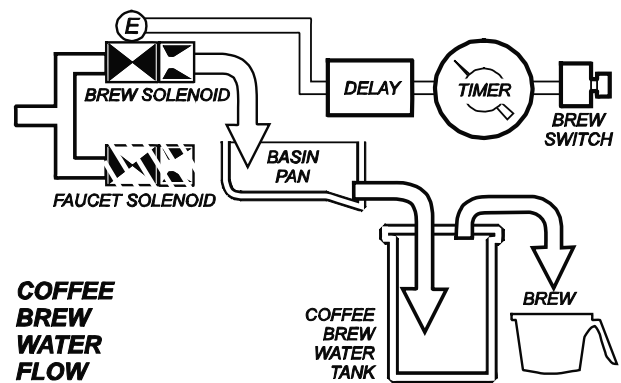

HOT WATER FAUCET

Water level in the faucet water tank is sensed by an electronic probe. When no water is sensed at the probe, the controller energizes the faucet side of the fill solenoid.

NOTE:

If water is not detected at water level probe for two minutes, unit will shut down.

NOTE:

The faucet is gravity fed from a tap in the faucet water tank.

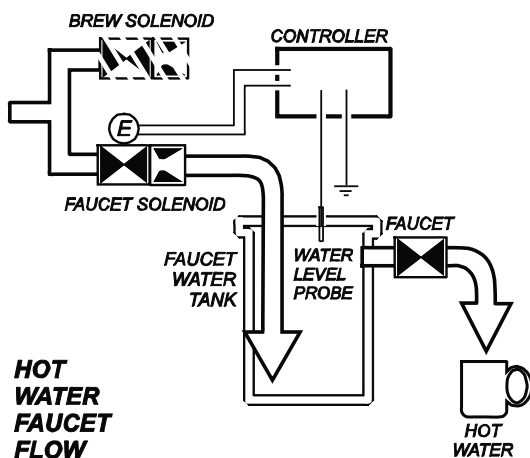

Fig. 6 Water Flow Diagrams

IL2327

BREWING COFFEE



CAUTION: BURN HAZARD

Exposed surfaces of the brewer, brew chamber and decanter may be HOT to the touch, and can cause serious burns.



CAUTION: BURN HAZARD

To avoid splashing or overflowing hot liquids, ALWAYS place an empty decanter under the brew chamber before starting the brew cycle. Failure to comply can cause serious burns.



CAUTION: BURN HAZARD

After a brew cycle, brew chamber contents are HOT. Remove the brew chamber and dispose of used grounds with care. Failure to comply can cause serious burns.

IMPORTANT:

Brew delay feature prevents multiple brews. A second brew cannot be started until a fixed time after the end of the previous brew. Pressing the BREW button during the delay time will cause a beep to sound and the SERVICE FAUCET TANK light to flash.

A. PREPARATION

Place one (1) genuine Bloomfield paper filter in the brew chamber. Add a pre-measured amount of fresh coffee grounds. Gently shake the brew chamber to level the bed of grounds. Slide the brew chamber into place under the brew head.

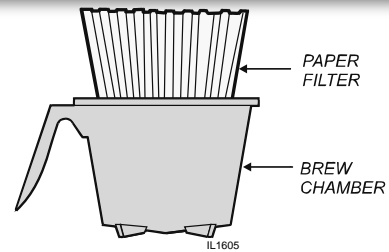

Fig. 7 Brew Chamber

B. AUTOMATIC OPERATION

BE sure "READY - COFFEE SYSTEM" light is lit.

Place the appropriate EMPTY decanter in place under the brew chamber on the bottom warmer.

Press BOTTOM warmer switch to ON to energize the bottom warmer.

Press the "BREW" button. The solenoid will open for an amount of time determined by the timer setting, admitting a measured quantity of water into the tank.

Inlet water will displace a like amount of heated water from the coffee brew water tank. The hot water will be forced into the brew head where it will spray over the bed of grounds. Freshly brewed coffee will begin to fill the container under the brew chamber.

When the flow and all dripping stops, the coffee is ready to serve.

Discard the contents of the brew chamber and rinse it in a sink. At conclusion of brew delay, the brewer is ready for another brew cycle.

C. WARMERS

Press TOP FRONT warmer switch or TOP REAR warmer switch to ON. Set the decanter of freshly brewed coffee on the appropriate warmer.

IMPORTANT: DO NOT leave an empty decanter on an energized warmer. DO NOT allow a decanter to boil dry.

CLEANING INSTRUCTIONS

PROCEDURE: Clean Coffee Brewer

PRECAUTIONS: Disconnect brewer from electric power.
Allow brewer to cool.

FREQUENCY: Daily

TOOLS: Mild Detergent, Clean Soft Cloth or Sponge
Bristle Brush, Bottle Brush

1. Turn main power switch OFF.
Allow brewer to cool before cleaning.
2. Remove decanters.
3. Remove and empty brew chamber.
4. Remove the spray disk from the brew head (See figure 8):
Press up on the spray disk ears, then turn the disk to the left to unlatch. Remove the gasket from inside the brew head.
5. Wipe inside of brew head and area around the brew head with a soft clean cloth or sponge moistened with clean water.
6. Wash the spray disk in a sink using warm water and a mild detergent. A bristle brush may be used to clear clogged spray holes. Rinse the spray disk with clean water and allow to air dry.
7. Wash the brew chamber in a sink using warm water and a mild detergent. Rinse with clean water and allow to air dry.
8. Wipe the exterior of the brewer with a soft clean cloth or sponge moistened with clean water.
10. Reinstall the gasket **INSIDE** the brew head, then reinstall the spray disk.
11. Reinstall the brew chamber.
12. Clean decanters by filling with warm soapy water. Scrub the inside with a bottle brush. Empty and rinse with clean water. Wipe the exterior with a soft clean cloth or sponge moistened with clean water. Invert and allow to air dry.

Procedure is complete



**CAUTION:
BURN HAZARD**

Brewing and serving temperatures of coffee are extremely hot. Hot coffee will cause serious skin burns.



**CAUTION:
SHOCK HAZARD**

Do not submerge or immerse brewer in water.

IMPORTANT:

DO NOT use steel wool, sharp objects, or caustic, abrasive or chlorinated cleansers to clean the brewer or decanters.

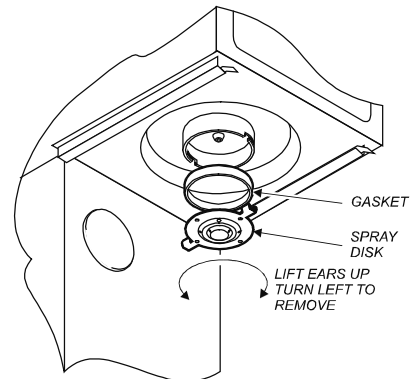

Fig. 8 Brew Head Cleaning

TROUBLESHOOTING SUGGESTIONS

SYMPTOM	POSSIBLE CAUSE	SUGGESTED REMEDY
Water won't heat	Circuit breaker tripped, main power switch or tank heat switch turned off	Check / reset circuit breaker. Turn switches on.
	Temperature setpoint too low	Set for desired temperature
	Hi-Limit safety switch tripped	Allow to cool, reset hi-limit reset
	Damaged internal component or wiring	Examine wiring & connectors, controller, power board and heating element. Repair/replace as needed
Coffee level too high or low	Timer out of adjustment	Adjust timer
Brew chamber overflows	Too many filter papers or wrong filter paper	Use one (1) genuine Bloomfield filter per brew
	Brew chamber dispense hole plugged	Thoroughly clean brew chamber
	Too much coffee or too fine a grind	Use correct grind and amount of coffee
Sprays water from brew head	Spray gasket improperly installed	Check/reinstall gasket on INSIDE of brew head
No brew	Spray disk plugged	Clean spray disk
	Damaged internal component or wiring	Check switch, timer, solenoid, Repair, replace as needed
No brew plus no flow from hot water faucet	Water supply OFF	Turn water supply ON
	Solenoid inlet strainer plugged	Clean strainer
	Water filter (if used) plugged	Replace filter element
No flow from hot water faucet	Faucet plugged	Disassemble faucet, clean
Continuous flow or drip from brew head	Damaged solenoid	Replace solenoid
	Faucet water level probe limed-up or has calcium deposits. "service tank" indicator lit	Delime faucet water tank
Poor coffee quality	Keep brewer and decanters clean. Install a taste and odor filter in water supply, and replace cartridges regularly. Use a quality coffee with a consistent roast. Use proper grind and amount of coffee per brew.	

SERVICING INSTRUCTIONS

ACCESS PANELS

TOP PANEL:

Remove top panel to access hot water tanks, thermostats, thermo probe, heating elements and main power switch.

Top panel is held by a retaining lip at the front and two screws near the middle top.

FRONT PANEL:

Remove front panel to access to terminal block, brew timer, brew delay and faucet water level controller.

Front panel is held by two retaining clips under main warmer cover plate and a retaining lip at the top.

SOLENOID DOOR:

Remove solenoid door to access solenoid plumbing connections. Solenoid door is held by two screws and a retaining lip.

THERMOSTAT ADJUSTMENT:

Thermostat adjustments may be accessed by removing appropriate button plug from right side. Rear/upper is for faucet water, front/lower is for coffee brew water.

WARMER ELEMENTS:

Element covers unscrew by turning counterclockwise. Warmer elements lift out.



**CAUTION
SHOCK HAZARD**

Opening access panels or removing warmer plates on this brew may expose uninsulated electrical components. Disconnect brewer from electrical power before removing any panel.

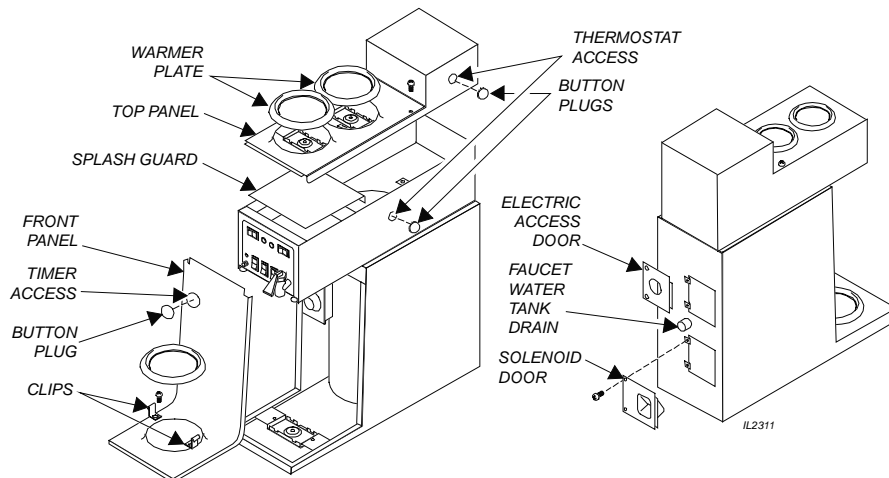

Fig. 9 Access Panels

SERVICING INSTRUCTIONS (continued)

TEMPERATURE ADJUSTMENT

Thermostat control may be accessed by removing either of the two button plugs on the right side of the brewer. Front control is COFFEE BREW temperature; rear control is FAUCET WATER temperature.

Place empty container under brew chamber or faucet. Energize brewer and allow unit to heat. When READY indicator lights, press BREW button, or raise faucet lever. Read temperature of water entering container.

Adjust WATER TEMP shaft on thermostat; clockwise increases temperature. Refer to Table 1 below for proper brewing temperature based on altitude.

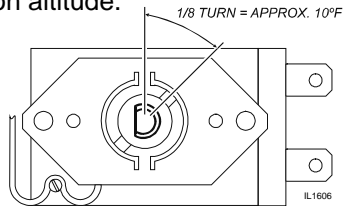

Fig. 10 Adjusting Brew Temperature

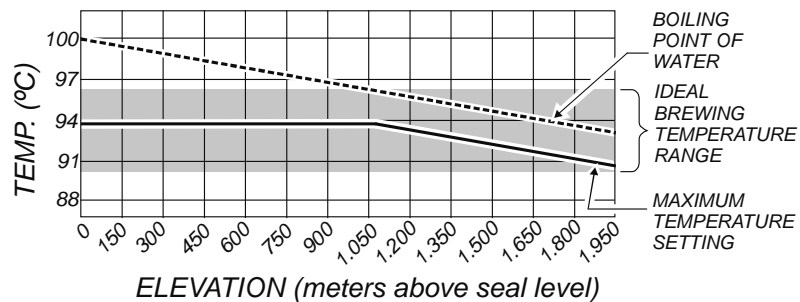
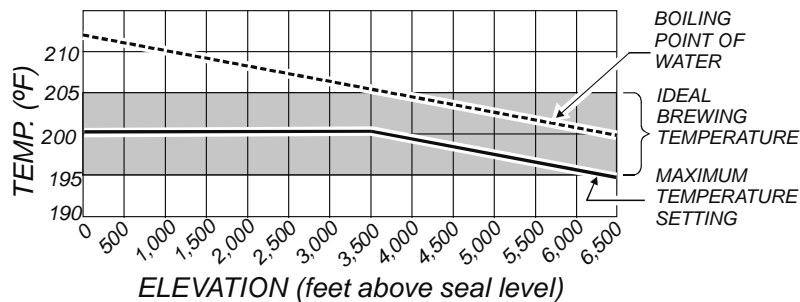

Table 1 Boiling Temperature by Altitude

Upon completion reinstall button plug(s).



CAUTION: SHOCK HAZARD

These procedures involve exposed electrical circuits. These procedures are to be performed by qualified technical personnel only.

Adjustments to be performed by qualified technician only.

NOTE: Optimum coffee brewing temperature is 195°F to 205°F (90°C to 96°C).

Thermostat should be adjusted to a maximum temperature of 203°F (95°C).

NOTE: Water temperature adjustments may be made by removing the appropriate button plug from the side of the brewer, then turning the thermostat adjustment shaft. Check water temperature at the brew head for coffee, or at the faucet for hot water. Because of losses in the connecting piping, the procedure at left provides a more accurate gauge of the actual tank temperature.

IMPORTANT:

A mechanical thermostat will maintain temperature within $\pm 5^\circ\text{F}$ ($\pm 3^\circ\text{C}$).

To prevent boiling water in the brewer, controller should be adjusted to a maximum temperature of 10°F (6°C) less than the local boiling temperature, or 202°F (94°C), whichever is less.

NOTE:

1/8 turn = approx 10°F (5.5°C)

SERVICING INSTRUCTIONS (continued)

BREW TIME ADJUSTMENT

Remove brew chamber and button plug. Adjust TIMER shaft; clockwise increases time. Brewer should dispense one full decanter of water. Run several cycles to check amount of water delivered. Replace button plug.

BREW DELAY ADJUSTMENT

Remove front panel. Adjust DELAY on timer board. Clockwise increases time. Reinstall front panel.

REMOVE TANK LID ASSEMBLY

Disconnect brewer from electric power. Turn OFF water supply. Remove top panel.

Disconnect fill and outlet tubes from tank lid fittings.

Disconnect all wiring from hi-limit, thermostat and heating element.

Loosen two lid retainer nuts. Slide retainer out of the way. Remove cover assembly by lifting it straight up.

Reassemble in reverse order.

REPLACE THERMOSTAT

Unplug brewer. Remove top panel.

Disconnect wiring from thermostat. Loosen screws holding thermostat to bracket.

Loosen thermobulb gland nut. Withdraw thermobulb from well.

Reassemble in reverse order. Adjust thermostat per page 12.

REPLACE TANK HEATING ELEMENT

Remove tank lid assembly per above.

Remove two hex nuts holding element to cover. Pull element from mounting holes.

Reassemble in reverse order.

REPLACE SOLENOID

Disconnect brewer from electric power. Turn OFF and disconnect water supply from brewer inlet fitting.

Remove two screws holding solenoid access door in place.

Remove two screws holding solenoid bracket to door. Unscrew inlet fitting cap and remove solenoid from door.

Remove wiring from solenoid.

Remove tubing from old solenoid and transfer to new solenoid.

Reassemble in reverse order.

IMPORTANT: Water pressure must be between 20 p.s.i and 90 p.s.i. flowing pressure. If water pressure exceeds this value, or if water pressure varies greatly, a pressure regulator must be installed in the water supply line.

IMPORTANT: Before setting assembly into tank, make sure tank lid gasket is properly seated on flange of lid.

IMPORTANT: When replacing thermostat, be sure to push thermo bulb fully to bottom of thermo well. Tighten gland lock nut only enough to ensure no water leakage. Excessive tightening is not necessary.

IMPORTANT: When replacing heating element, also replace seal gaskets.

SERVICING INSTRUCTIONS (continued)



CAUTION CHEMICAL BURN HAZARD

Deliming chemicals may be caustic. Wear appropriate protective gloves and goggles during this procedure. Never siphon deliming chemicals or solutions by mouth. This operation should only be performed by qualified and experienced service personnel.

IMPORTANT: DO NOT spill, splash or pour water or deliming solution into or over any internal component other than the inside of the water tank.

IMPORTANT: DO NOT allow any internal components, other than those in the water system, to come into contact with the deliming solution. Take care to keep all internal components dry.

NOTE: Repeat steps 4 thru 5 as required to remove all scale and lime build-up.

NOTE: Normally, silicone hoses do not need to be delimed. Should deliming hoses become necessary, Bloomfield recommends replacing the hoses.

PROCEDURE: Delime Coffee Water Tank

PRECAUTIONS: Disconnect brewer from electric power. Allow brewer to cool.

FREQUENCY: As required (coffee water slow to heat)

TOOLS: Deliming Solution
Protective Gloves, Goggles & Apron
Mild Detergent, Clean Soft Cloth or Sponge
Bristle Brush, Bottle Brush
Large Sink (or other appropriate work area)

1. Disconnect brewer from electric power. Turn the water shut-off valve OFF and disconnect the water supply line from the brewer inlet fitting.
2. Remove the tank lid assembly as described on page 13.
3. Remove the coffee water tank from the brewer body by lifting straight up. Empty all water from the tank. Set the tank back into the brewer.
4. Mix 2 quarts of deliming solution according to the manufacturer's directions. Carefully pour the deliming solution into the water tank. Lower the lid assembly back onto the tank. Allow to sit for 30 minutes, or as directed by the manufacturer.
5. At end of soaking period, remove lid assembly from tank. Thoroughly rinse internal components of lid assembly with clear water. Using a stiff bristle brush, scrub the heating element and faucet water coil to remove lime and calcium build-up. Rinse with clean water. Store lid assembly in a safe location.
6. Remove the tank from the brewer and empty. Using a stiff bristle brush, scrub the interior of the water tank to remove lime and calcium build-up. Rinse with clean water.
7. Set the tank back into the brewer. Reassemble the tank lid to the water tank. Make sure the gasket is properly in place, then reinstall lid clamps.
8. Reinstall wiring to heating element and thermostat. Verify that all internal components are dry, then reinstall the top panel.
9. Reconnect brewer to electrical supply and reconnect water supply.
11. Install the brew chamber without filter paper or grounds. Run at least three full brew cycles and discard all water generated.
12. Brewer is ready to use.

SERVICING INSTRUCTIONS (continued)

PROCEDURE: Delime Faucet Water Tank

PRECAUTIONS: Disconnect brewer from electric power.
Allow brewer to cool.

FREQUENCY: As required (SERVICE TANK light flashes)

TOOLS: Deliming Solution
Protective Gloves, Goggles & Apron
Mild Detergent, Clean Soft Cloth or Sponge
Bristle Brush, Bottle Brush
Large Sink (or other appropriate work area)

1. Disconnect brewer from electric power. Turn the water shut-off valve OFF and disconnect the water supply line from the brewer inlet fitting.
2. Remove the tank lid assembly as described on page 13.
3. Drain all water from the tank using the tank drain on the back of the brewer. Replace drain cap.
4. Mix 2 quarts of deliming solution according to the manufacturer's directions. Carefully pour the deliming solution into the water tank. Lower the lid assembly back onto the tank. Allow to sit for 30 minutes, or as directed by the manufacturer.
5. At end of soaking period, remove lid assembly from tank. Thoroughly rinse internal components of lid assembly with clear water. Using a stiff bristle brush, scrub the heating element and faucet water coil to remove lime and calcium build-up. Rinse with clean water. Store lid assembly in a safe location.
6. Drain all water from the tank. Using a stiff bristle brush, scrub the interior of the water tank to remove lime and calcium build-up. Rinse with clean water, drain, then replace drain cap.
7. Reassemble the tank lid to the water tank. Make sure the gasket is properly in place, then reinstall lid clamps.
8. Reinstall wiring to heating element and thermostat.
9. Verify that all internal components are dry, then reinstall the top panel.
10. Reconnect brewer to electrical supply and reconnect water supply.
11. Run and discard at least three full decanters of water from the faucet.
12. Brewer is ready to use.



CAUTION CHEMICAL BURN HAZARD

Deliming chemicals may be caustic. Wear appropriate protective gloves and goggles during this procedure. Never siphon deliming chemicals or solutions by mouth.

This operation should only be performed by qualified and experienced service personnel.

IMPORTANT: DO NOT spill, splash or pour water or deliming solution into or over any internal component other than the inside of the water tank.

IMPORTANT: DO NOT allow any internal components, other than those in the water system, to come into contact with the deliming solution. Take care to keep all internal components dry.

NOTE: Repeat steps 4 thru 5 as required to remove all scale and lime build-up.

NOTE: Normally, silicone hoses do not need to be delimed. Should deliming hoses become necessary, Bloomfield recommends replacing the hoses.

EXPLODED VIEW & PARTS LIST

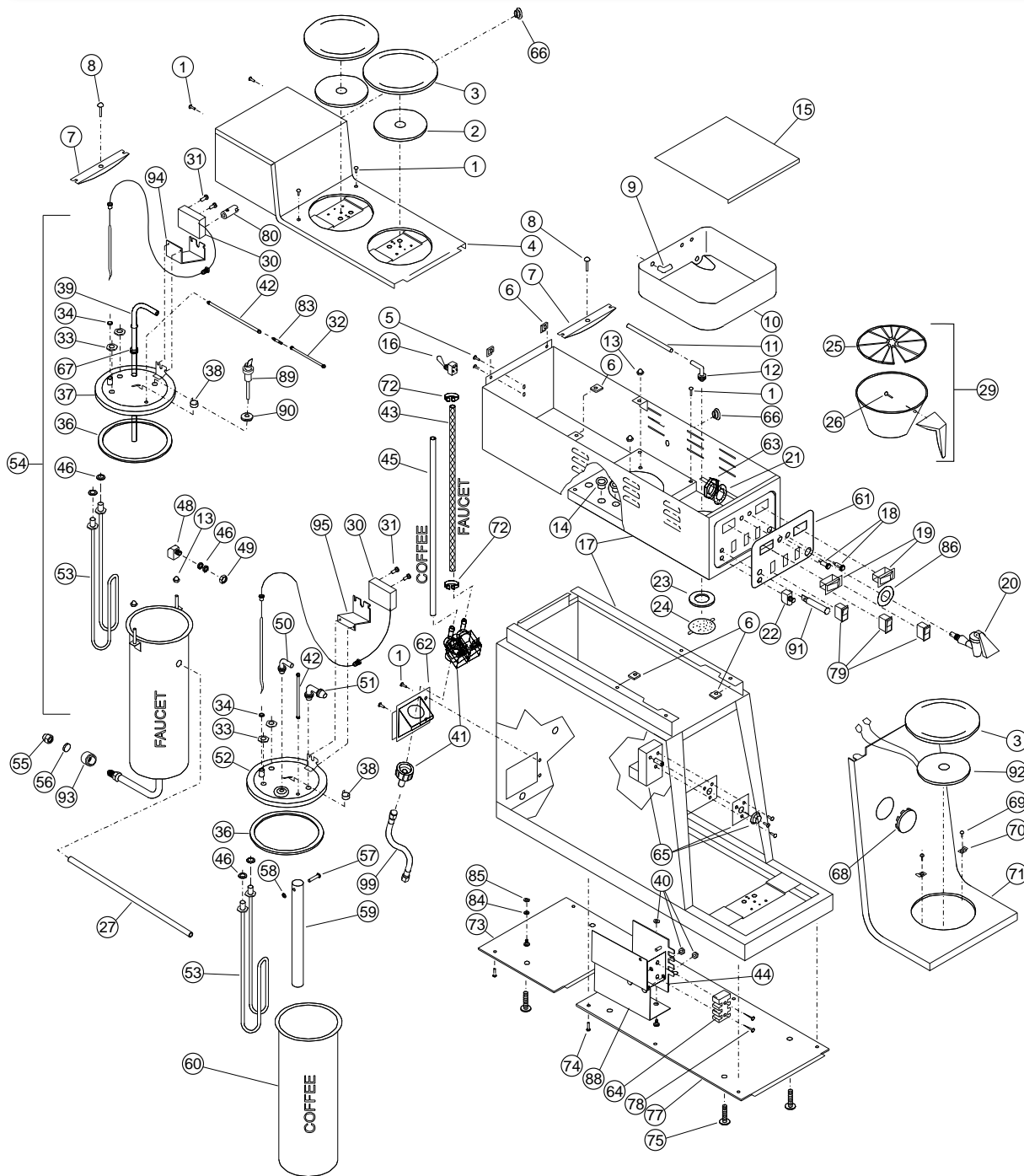

Model: 8783D3FM-240

IL2324a-915

915 2M-Z15131 Owners Manual for 8783MCD

EXPLODED VIEW & PARTS LIST (continued)

Model 8783D3FM-240			
FIG	PART NO.	DESCRIPTION	QTY
1	2C-70092	SCREW PHL SS 8-32x3/8	6
2	2N-70635UL	ELEMENT, WARMER 100W 240V	2
3	2D-70090	COVER PLATE, WARMER, 1/4-28 STUD	3
	2D-Z15630	PLATE COVER, WARMER, 1/4-20 STUD	
4	DD-8783-5	BASIN COVER SUB ASSY	1
5	2C-70379	SCREW 8-32x5/16	2
6	2C-70132	NUT TINNERMAN #8	20
7	2C-70134	HOLD DOWN STRAP, TANK CVR	2
8	2C-70135	SCREW 10-32 x 1 PAN	2
9	2K-70096	ELBOW POLYPROPYLENE	1
10	DD-71055	PAN BASIN	1
11	2V-70131	TUBE OUTLET WATER	1
12	2K-70130	ELBOW SPRAYER	1
13	2C-70133	NUT, ACORN 8-32 SS	4
14	2K-70229	BUSHING 7/8 HEYCO	3
15	A6-70981	COVER, BASIN PAN	1
16	2E-30330	SWITCH, MAIN POWER	1
17		ASSY, BASIN BODY & BASE	1
18	2J-70644	LIGHT PILOT GREEN 250V	2
19	2E-70993	SWITCH, TANK HEATER	2
20	2U-71061	ASSY FAUCET	1
21	2C-72148	WASHER LOCK INT 1/2 ID SE	1
22	2E-70137	SWITCH, BREW START	1
23	2I-70139	GASKET SPRAY HEAD	1
24	A6-72727	SPRAY DISK EMBOSSED	1
25	2V-70116	WIRE RACK, BREW CHAMBER	1
26	2C-70115	SCREW 10-32 x 5/16	1
27	D7-70699	HOSE, HOT WATER FAUCET	1
29	4J-8707-6	ASSY, BREW CHAMBER SS	1
30	WS-8512-51	THERMOSTAT CONTROL BREWERS	2
31	2C-70405	SCREW 6-32 x 1/4 (part of ITEM 30)	4
32	2V-70102	TUBE VENT	1
33	2C-70175	NUT HEX 1/2-20 BRASS	4
34	2C-70174	WELL, THERMO (part of ITEM 30)	2
35			
36	2I-70147	GASKET, TANK COVER	2
37	DD-71085	TANK COVER (FAUCET)	1
38	2T-72956	THERMOSTAT, HI-LIMIT	2
39	2V-73034	FILL TUBE, FAUCET TANK	1
40	2C-35455	NUT HEX 8-32	3
41	DD-76107	SOLENOID VALVE DUAL .75GPM 240V	1
42	2V-70398	TUBE VENT LONG	2
43	A6-76237	TUBE BRAIDED .312 ID x 17"	1
44	2E-72111	WATER LEVEL CONTROL BOARD	1
45	WS-86108	TUBE SILICONE .312 ID x 19"	1
46	2I-70152	GASKET, HEATING ELEMENT	6
47			
48	F4-70420	ELBOW, OUTLET BRASS	1
49	2C-70410	NUT HEX 1/2-24 BRASS	1

Model 8783D3FM-240			
FIG	PART NO.	DESCRIPTION	QTY
50	2K-70103	ELBOW, OUTLET	1
51	2K-70101	ELBOW INLET	1
52	A6-72959	TANK COVER (COFFEE)	1
53	2N-70173UL	ELEMENT 240V 1800W	2
54	WS-8783-21	ASSY, TANK (FAUCET)	1
55	DD-71054	CAP DRAIN PLATE	1
56	DD-67183	CAP DRAIN SEAL HD	1
57	2C-70145	SCREW 4-40 x 1-1/2 PAN	1
58	2C-70146	NUT HEX 4-40	1
59	2V-70144	TUBE WATER INLET	1
60	2D-70110	TANK (COFFEE)	1
61	2M-72127	DECAL 8783 BASIN	1
62	2Q-75089	ACCESS DOOR, PLASTIC	1
63		NUT (part of ITEM 20)	1
64	2E-70709	TERMINAL BLOCK 4 POLE	1
65	2P-70054	TIMER W/KNOB 2-MIN 240V	1
66	2P-70275	PLUG, BUTTON 3/8"	2
67	2I-72390	GROMMET .375 ID TRANSLUSCENT	1
68	2P-70053	PLUG, BUTTON 2"	1
69	2C-70099	SCREW 8-32 x 3/8	2
70	2C-70098	CLIP MOUNTING	2
71	A6-70268	PANEL FRONT	1
72	2C-74212	HOSE CLAMP 11/16 PLASTIC	2
73	A6-71070	ASSY, PLATE BOTTOM REAR	1
74	2C-70127	SCREW 8-32 x 3/8 PHL	8
75	2A-71732	ASSY, LEVELING LEG & CAP	4
76			
77	A6-70256	PLATE, BOTTOM FRONT	1
78	2C-70307	SCREW 6-32 x 3/4	2
79	2E-Z15131	SWITCH ON OFF LTD BLACK	3
80	DD-48538	ADAPTER, THERMO SHAFT	1
81	A6-75259	ASSY, QUICK DISCONNECT	1
82			
83	2K-72241	FTG HOSE CONNECTOR STRIAIGHT	1
84	2C-72148	WASHER LOCK INT 1/2 ID	1
85	DD-70220	NUT HEX 10-24	1
86			
87			
88		BRACKET, CIRCUIT BOARD	1
89	2J-72114	PROBE, WATER LEVEL	1
90	2I-72115	GROMMET 1/4 ID	1
91	DD-72122	LIGHT PILOT RED	1
92	2N-72529UL	ELEMENT, WARMER 100W 240V	1
93	DD-72260	NUT RETAINER	1
94	DD-72562	BRACKET, THERMO FAUCET	1
96	DD-87491	DOOR, ELECTRIC SERVICE	1
97			
98			
99	2J-70942	HOSE POLY BRAID	1
100			

SERVICE KITS

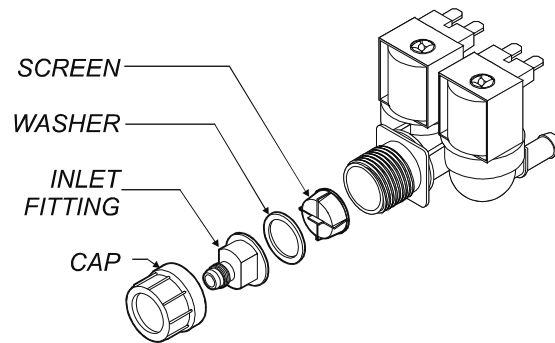

SERVICE KITS

SOLENOID REPAIR KITS

- DD-76107 Solenoid Complete, Dual
- WS-85218 Inlet Fitting Kit (includes cap, inlet fitting, washer and screen)
- WS-85219 Inlet Strainer (includes screen only)

WIRING DIAGRAM

76215
ISSUE (A)
SH. 1 OF 1

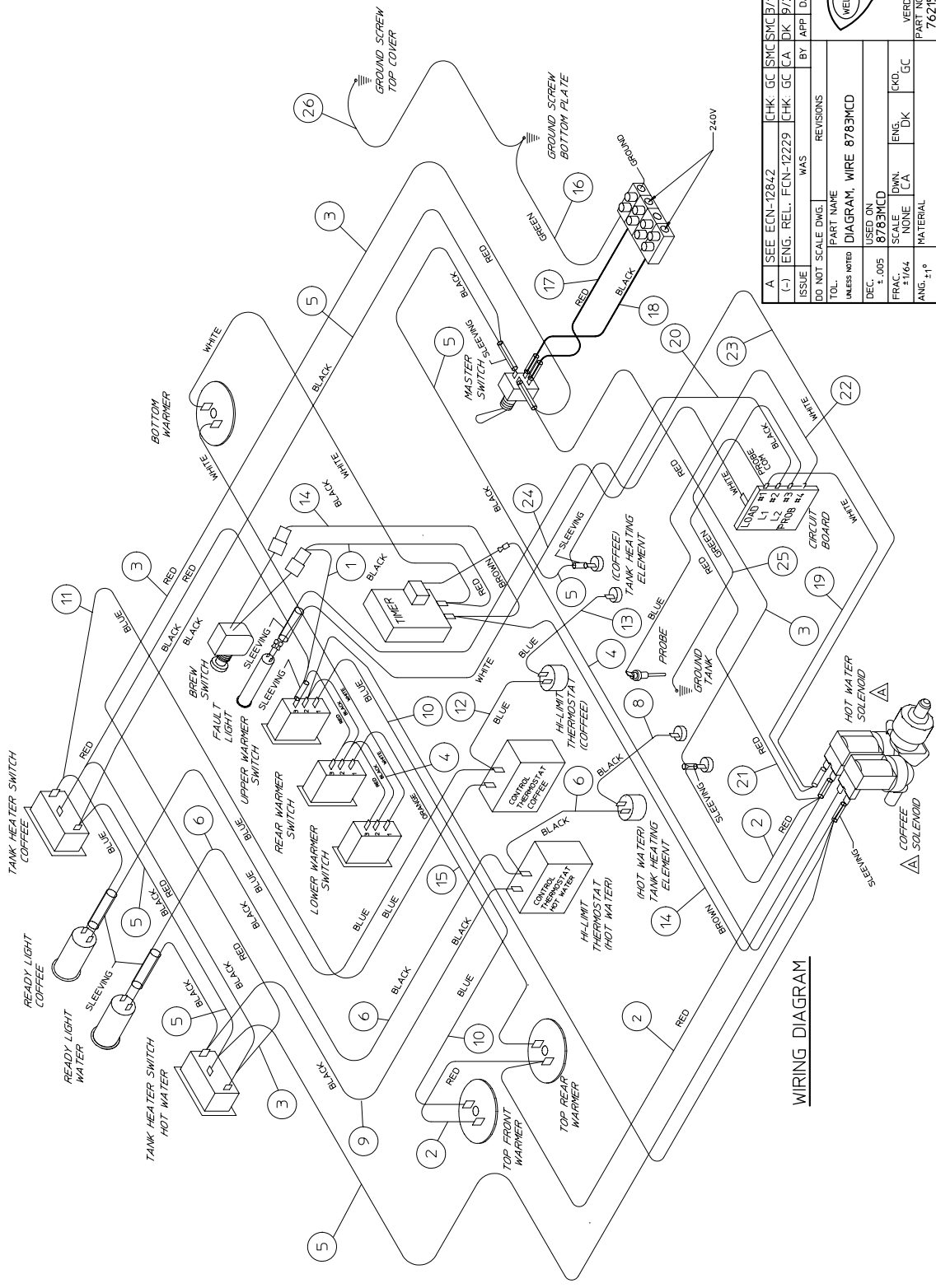

A	SEE ECN-12842	CHK	GC	SNC	SNC	B/14/05
(-)	ENG. REL. FCN-12229	CHK	GC	A	DK	B/24/02
ISSUE	DO NOT SCALE DWG.	WAS	REVISIONS	BY	API	DATE
TOL.	PART NAME					
UNLESS NOTED	DIAGRAM, WIRE 8783MCD					
DEC.	USED ON					
FRAC.	SCALE	DWN.	ENG.	CHK.	GC	VERDI. NV.
ANG.	1/164	NONE	CA	DK	GC	PAT. NO. *
	MATERIAL					
	ANG. ±1°					



915 2M-Z15131 Owners Manual for 8783MCD

NOTES

NOTES



Wells Bloomfield proudly supports CFESA
Commercial Food Equipment Service Association

SERVICE TRAINING - QUALITY SERVICE



CUSTOMER SATISFACTION

WELLS BLOOMFIELD

WELLS BLOOMFIELD, LLC

10 Sunnen Drive, St. Louis, MO 63143
telephone: 314-678-6336 fax: 314-781-2714
www.wellsbloomfield.com