

BLOOMFIELD INDUSTRIES

265 Hobson St.
Smithville, TN 37166
telephone: 314-678-6336
fax: 314-781-2714
www.wellsbloomfield.com



Model 9221EUFC Dual Satellite Brewer

**OWNERS MANUAL
for**

**SS2 - SERIES
DUAL SATELLITE
COFFEE BREWERS
with
ELECTRO-MECHANICAL
CONTROL
and
EXTERNALLY HEATED
SATELLITE SERVERS**

**MODEL:
9221EUFC**

Includes:

**Installation
Operation
Use & Care
Servicing Instructions**

WARRANTY STATEMENT

All electrical equipment manufactured by BLOOMFIELD INDUSTRIES is warranted against defects in materials and workmanship for a period of one year from the date of original installation or eighteen (18) months from the date of shipment from our factory, whichever comes first, and is for the benefit of the original purchaser, except that:

- a. airpots carry a 30 day parts warranty only.
- b. dispensers; i.e., tea and coffee carry a 90 days parts warranty only, excludes decanters.

THE FOREGOING OBLIGATION IS EXPRESSLY GIVEN IN LIEU OF ANY OTHER WARRANTIES, EXPRESSED OR IMPLIED, INCLUDING ANY IMPLIED WARRANTY OF MERCHANTABILITY OR FITNESS FOR A PARTICULAR PURPOSE, WHICH ARE HEREBY EXCLUDED.

BLOOMFIELD INDUSTRIES DIVISION / SPECIALTY EQUIPMENT MANUFACTURING CORPORATION SHALL NOT BE LIABLE FOR INDIRECT, INCIDENTAL OR CONSEQUENTIAL DAMAGES OR LOSSES FROM ANY CAUSE WHATSOEVER.

This warranty is void if it is determined that upon inspection by an Authorized Service Agency that the equipment has been modified, misused, misapplied, improperly installed, or damaged in transit or by fire, flood or act of God.

It also does not apply if the serial nameplate has been removed or unauthorized service personnel perform service. The prices charged by Bloomfield Industries for its products are based upon the limitations in this warranty. Seller's obligation under this warranty is limited to the repair of defects without charge by a Bloomfield Industries Authorized Service Agency or one of its sub-agencies. This service will be provided on customer's premises for non-portable models. Portable models (a device with a cord and plug) must be taken or shipped to the closest Authorized Service Agency, transportation charges prepaid, for services.

In addition to restrictions contained in this warranty, specific limitations are shown below (Additional Warranty Exclusions). Bloomfield Industries Authorized Service Agencies are located in principal cities.

This warranty is valid in the United States and void elsewhere. Please consult your classified telephone directory or your food service equipment dealer; or, for information and other details concerning warranty, write to:

**Service Parts Department
Wells Bloomfield, LLC
265 Hobson St. Smithville, TN 37166**

Phone: (775) 689-5700

Fax: (888) 492-2783

SERVICE POLICY AND PROCEDURE GUIDE ADDITIONAL WARRANTY EXCLUSIONS

1. Resetting of safety thermostats, circuit breakers, overload protectors, or fuse replacements unless warranted conditions are the cause.
2. All problems due to operation at voltages other than specified on equipment nameplates; conversion to correct voltage must be the customer's responsibility.
3. All problems due to electrical connections not made in accordance with electrical code requirements and wiring diagrams supplied with the equipment.
4. Replacement of items subject to normal wear, to include such items as knobs and light bulbs. Normal maintenance functions including adjustment of thermostats, microswitches, and replacement of fuses and indicating lights are not covered under warranty.
5. All problems due to inadequate water supply, such as fluctuating, or high or low water pressure.
6. All problems due to mineral/calcium deposits, or contamination from chlorides/chlorines. De-liming is considered a preventative maintenance function and is not covered by warranty.
7. Full use, care and maintenance instructions are supplied with each machine. Those miscellaneous adjustments noted are customer responsibility. Proper attention will prolong the life of the machine.
8. Travel mileage is limited to sixty (60) miles from an authorized Service Agency or one of its sub-agencies.
9. All labor shall be performed during normal working hours. Overtime premium shall be charged to the customer.
10. All genuine Bloomfield replacement parts are warranted for ninety (90) days from date of purchase on non-warranted equipment. **Any use of non-genuine Bloomfield parts completely voids any warranty.**
11. Installation, labor and job check-out are not considered warranty.
12. Charges incurred by delays, waiting time or operating restrictions that hinder the service technicians ability to perform services are not covered by warranty. This includes institutional and correctional facilities.

SHIPPING DAMAGE CLAIMS PROCEDURE

NOTE: For your protection, please note that equipment in this shipment was carefully inspected and packaged by skilled personnel before leaving the factory. Upon acceptance of this shipment, the transportation company assumes full responsibility for its safe delivery.

IF SHIPMENT ARRIVES DAMAGED:

1. **VISIBLE LOSS OR DAMAGE:** Be certain that any visible loss or damage is noted on the freight bill or express receipt, and that the note of loss or damage is signed by the delivery person.
2. **FILE CLAIM FOR DAMAGE IMMEDIATELY:** Regardless of the extent of the damage.

3. **CONCEALED LOSS OR DAMAGE:** if damage is unnoticed until the merchandise is unpacked, notify the transportation company or carrier immediately, and file "CONCEALED DAMAGE" claim with them. This must be done within fifteen (15) days from the date the delivery was made to you. Be sure to retain the container for inspection.

Bloomfield Industries cannot assume liability for damage or loss incurred in transit. We will, however, at your request, supply you with the necessary documents to support your claim.

TABLE OF CONTENTS

WARRANTY STATEMENT	xi
SPECIFICATIONS	1
FEATURES & OPERATING CONTROLS	2
PRECAUTIONS & GENERAL INFORMATION	4
AGENCY APPROVAL INFORMATION	4
INSTALLATION	5
OPERATION	8
CLEANING INSTRUCTIONS	10
SERVICING INSTRUCTIONS	12
TROUBLESHOOTING SUGGESTIONS	16
SATELLITE EXPLODED VIEW & PARTS LIST	17
BREWER EXPLODED VIEWS & PARTS LISTS	18
WIRING DIAGRAM	22

Thank You for purchasing this Bloomfield Industries appliance.

Proper installation, professional operation and consistent maintenance of this appliance will ensure that it gives you the very best performance and a long, economical service life.

This manual contains the information needed to properly install this appliance, and to use, care for and maintain or repair the appliance in a manner which will ensure its optimum performance.

SPECIFICATIONS

MODEL	VOLTS 3NAC	WATTS	AMPS				HZ
			L1	L2	L3	N	
9221EUFC	380-415	6250	8.7	8.7	9.8	1.1	50/60

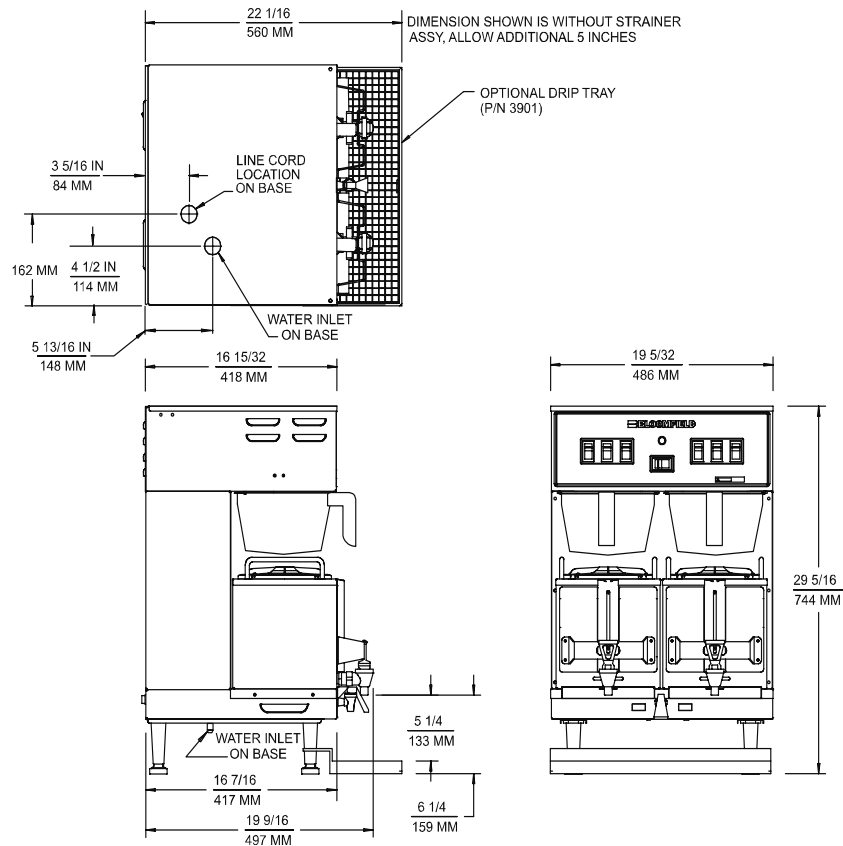

FEATURES AND OPERATING CONTROLS

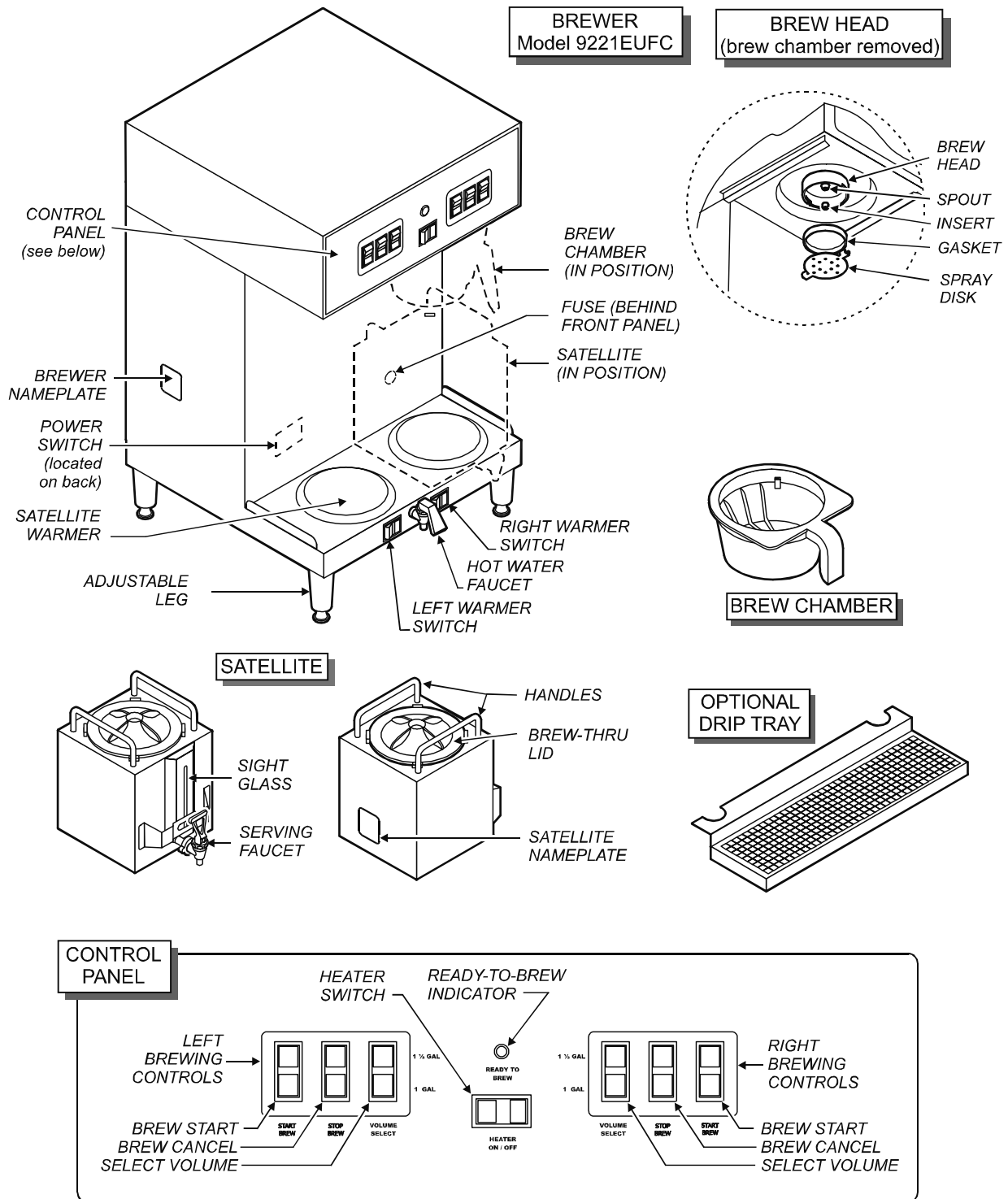

Fig 1. SS-2 Satellite Brewing System Features & Operating Controls

FEATURES AND OPERATING CONTROLS (continued)

Brewer

Adjustable Legs	Allows brewer to be leveled. Also allow clearance for cleaning underneath brewer.
Brewing Controls	Start or stop brew and select brew volume. Right and left section are independent.
Heater Switch	Turns power to tank heater <i>ON</i> or <i>OFF</i> .
Hot Water Faucet	Hot water dispensed here.
Nameplate	Lists manufacturer, model and serial number. Also lists voltage and wattage rating of brewer.
Ready-To-Brew Light	Glowes when the tank water is up to temperature.
System Switch (not shown)	Located on lower right rear of brewer. Turns main power to brewer <i>ON</i> or <i>OFF</i> .
Satellite Locator/Warmer	Positions externally heated satellite on brewer. Maintains temperature of product in satellite.
Warmer Switches	Control individual warmers for externally heated satellite .

Brew Chamber

Brew Chamber	Holds coffee grounds during brew cycle.
--------------	---

Satellite

Brew-Thru Lid	Allows entry of brewed coffee and dilution water into satellite. Minimizes splashing in the event satellite is tipped.
Handles	Allow the satellite to be safely carried.
Nameplate	Lists manufacturer, model and serial number. Also lists voltage and wattage rating of satellite.
Serving Faucet	Fresh coffee dispensed from satellite here.
Sight Glass	Check the level of coffee remaining here.

Drip Tray (optional)

Optional drip tray catches drips and spills from serving faucet.
Easily removed for cleaning.

GENERAL INFORMATION AND PRECAUTIONS



WARNING: Electric Shock hazard

All servicing requiring access to non-insulated electrical components must be performed by a factory authorized technician. DO NOT open any access panel which requires the use of tools. Failure to follow this warning can result in severe electrical shock.



CAUTION: Burn Hazard

Surfaces of this brewer can be hot and can cause burns on contact.

IMPORTANT !

Do not store any combustible materials or flammable liquids anywhere near the appliance.

This appliance is intended for use in commercial establishments only.

This appliance is intended to brew hot beverage, specifically coffee, for human consumption. No other use is recommended or authorized by the manufacturer or its agents.

Operators of this appliance must be familiar with the appliance use, limitations and associated restrictions. Operating instructions must be read and understood by all persons using or installing this appliance.

Cleanliness of this appliance is essential to good sanitation. Read and follow all included cleaning instructions and schedules to ensure the safety of the food product.

Surfaces of the brewer, brew basket and satellite can be hot to the touch, and may cause burns on contact.

Disconnect the brewer from electrical power before performing any maintenance or servicing.

DO NOT submerge satellites in water.

DO NOT splash or pour water over, onto or into any controls, control panel or wiring.

Any procedure which requires the use of tools must be performed by a qualified technician.

This manual is considered to be a permanent part of the appliance. This manual and all supplied instructions, diagrams, schematics, parts breakdown illustrations, notices and labels must remain with the appliance if it is sold or moved to another location.

This appliance is made in the USA. Unless otherwise noted, this appliance has American sizes on all hardware.

AGENCY APPROVAL INFORMATION



This dual satellite brewing system meets  Standards



STD 4

This dual satellite brewing system meets NSF Standard 4 only when installed and maintained per the instructions in this manual.

INSTALLATION INSTRUCTIONS

INSTALL LEGS & LEVEL THE UNIT

The brewer is provided with 4" (100 mm) adjustable legs and rubber feet. Be sure the legs are securely screwed into the base of the brewer, and that the rubber feet are properly installed.

The adjustable legs allow the brewer to be leveled. Set the brewer in its ultimate operating location and check for level with a spirit level. Adjust the brewer for level from front-to-rear, and from side-to-side. Be sure all four feet rest firmly on the counter.

PLUMBER'S INSTALLATION INSTRUCTIONS

IMPORTANT:

Brewer must be installed on a potable water supply line with a full-flow pressure between 20 psi (138 kPa) and 90 psi (620 kPa).

NOTE:

If water pressure varies greatly, or exceeds 90 psi (620 kPa) at any time, a water pressure regulator must be installed. Plumbing installer must supply the regulator.

Brewer must be connected to a potable water supply. Bloomfield recommends not less than 1/4" (6 mm) inside diameter copper tubing for installations of 12' (4 meters) or less, and not less than 3/8" (10 mm) I.d. copper tubing for installations exceeding 12' (4 meters).

Brewer must be connected to a COLD water line.

NOTE: DO NOT use a saddle tap for this water line connection.

A shut-off valve must be installed between the main water supply and the brewer. Plumbing installer must supply the shut-off valve. A 1/4-turn ball valve is recommended.

Flush the water line before connecting to the brewer.

Bloomfield highly recommends the use of the provided water strainer to help prevent deposits in the brewing system.

In some areas, local codes require a backflow preventer (check valve) to be installed on the inlet water line. If a backflow preventer is used, you must install a **water hammer arrester** in the incoming line, between the preventer and the brewer inlet, as far away from the brewer as space will allow. This will relieve excessive back pressure that can cause faucet leaks and solenoid malfunctions.



CAUTION: Hazard from Unstable Equipment

Rubber feet must be installed on each leg of the brewer. Legs must be adjusted so that all four feet rest firmly on the counter. Failure to properly install the feet can result in movement of the brewer, which can cause personal injury and/or damage to the brewer.

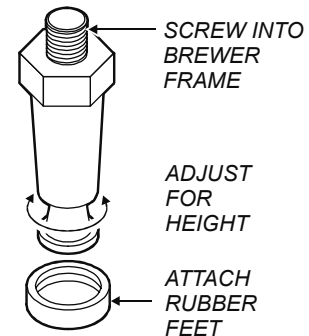

Fig. 2 Adjustable Leg



CAUTION: Electric Shock Hazard

Brewer must be properly grounded to a reliable earth ground to prevent possible shock hazard. Do not assume a plumbing line will provide such a ground. Electrical shock may cause serious injury.

INSTALLATION INSTRUCTIONS (continued)

IMPORTANT !

These installation instructions are prepared for personnel authorized, qualified, certified or licensed to install electrical equipment, who should perform all initial startup and adjustments.

IMPORTANT !

Do not store any combustible materials or flammable liquids anywhere near the appliance.

EUROPEAN ELECTRICAL INSTALLATION INSTRUCTIONS

IMPORTANT !

- Make sure the incoming voltage is the same voltage, frequency and phase as specified on the appliance nameplate. Connecting the appliance to the wrong voltage may cause severe damage to internal components, or may cause a severe decrease in performance.

IMPORTANT !

- An approved all pole power disconnect switch with at least a 3mm contact gap must be supplied and installed in the fixed wiring in an accessible location (close proximity to the appliance) by a licensed electrician. Refer to *General Layout Data* sheet for electrical ratings.

SUPPLY CORDS

- Power supply cords should be oil-resistant, sheathed flexible cable not lighter than ordinary polychloroprene or other equivalent synthetic elastomer-sheathed cord (code designation 245 IEC 57) or an approved metal conduit connection.
- Minimum cross sectional area of conductors per line must be 1.5 square mm and total length not to exceed 2 meters between supply connection and appliance. Supply wires must be suitable for at least 90°C temperature rating
- For flexible power cords, an approved strain relief fitting must be supplied by others.

WIRING CONNECTIONS

- Using a screwdriver, remove rear panel.
- Knock out the appropriate hole plug and connect conduit strain relief.
- Thread supply leads through strain relief and connect power leads to terminals marked "L1", "L2" & "L3". Connect neutral lead to terminal marked "N".
- Connect ground lead (green with yellow stripe) to ground lug marked "G".
- Secure all connections and reinstall terminal cover.

INSTALLATION INSTRUCTIONS (continued)

INITIAL SET-UP INSTRUCTIONS

Plumber's and Electrician's installation procedures must be completed before proceeding with the set-up.

Be sure all electrical connections are secure, and that all plumbing connections are secure and leak-proof.

IMPORTANT:

Initial set-up must be performed by a qualified installer or qualified service technician. Improper set-up will damage the brewer and void the warranty.

1. CHECK BREWER FOR PROPER CONFIGURATION

Make sure spray disk gaskets are in place **INSIDE** of spray heads.

Make sure spray disks are properly installed.

Check hot water faucet for proper operation and leaks.

Place empty satellites in position.

2. START BREWER OPERATION

Be sure **HEATER ON/OFF** switch is **OFF**, then press **POWER SWITCH** on back of unit to energize brewer.

Water Inlet Solenoid will energize, filling the tank with water. Fill time is approximately 13 minutes. Tank will fill until water is sensed at the water level probe. Water level will be maintained automatically once the tank is filled.

Press **HEATER ON/OFF** switch **ON**. Water in tank will heat to brewing temperature in approximately 30 minutes. When the water temperature reaches the brew temperature set point, the **READY-TO-BREW** light will glow.

3. FINAL CHECKS

After initial heat-up and before brewing, draw water from the hot water faucet until the inlet solenoid actuates. This will prevent volume differences to the initial brew caused by water expansion.

Press **SATELLITE WARMER** switch on. Brewer will not operate unless the appropriate **SATELLITE WARMER** switch on.

IMPORTANT:

Complete water line installation before connecting brewer to electrical power.

MAKE SURE THE FRONT PANEL "HEATER ON/OFF" SWITCH IS IN THE OFF POSITION BEFORE CONNECTING BREWER TO ELECTRICAL POWER.

DO NOT turn the **HEATER ON/OFF** switch on until the water tank is filled. Heating elements must be completely submerged in water at all times. Damage to the brewer caused by operating the heating elements dry is **NOT** covered by warranty.

NOTE: Brewer will not operate unless the appropriate **WARMER SWITCH** is turned **ON**.

OPERATING INSTRUCTIONS

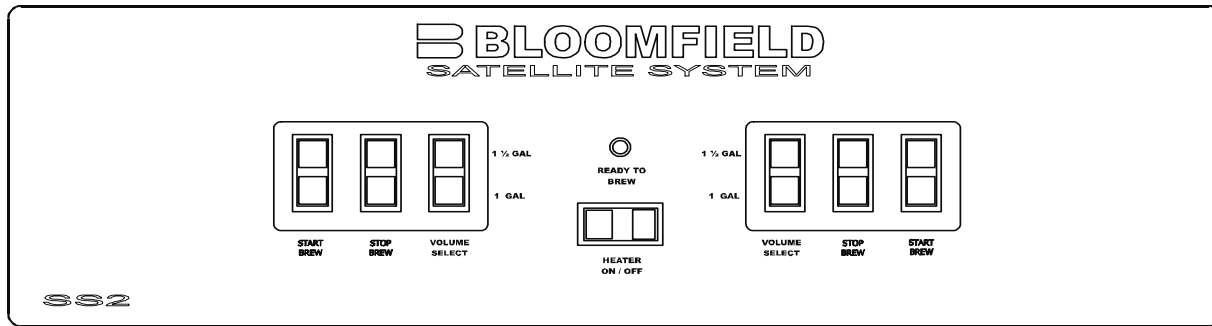

Fig. 3 Control Panel

GETTING STARTED

Check the brewer and satellites:

Check that the brewer is clean and the drip tray (if used) is empty.

Check that the satellites are empty and clean with lids properly installed.

Check the spray heads:

Remove the brew chambers. Check the spray heads. Verify that the spray disks are clean and properly installed. Verify that the gaskets are properly installed inside the spray heads.

Check the brew chambers:

Check that the brew chambers are clean.

START-UP

Press POWER SWITCH (back of brewer) to **ON**. Brewer water tank will begin filling.

When tank stops filling, press **HEATER ON/OFF switch to ON**: READY-TO-BREW light will glow when water is at proper temperature for brewing.

Press SATELLITE WARMER switches to **OFF** until ready to begin brewing.

OPERATING INSTRUCTIONS (continued)

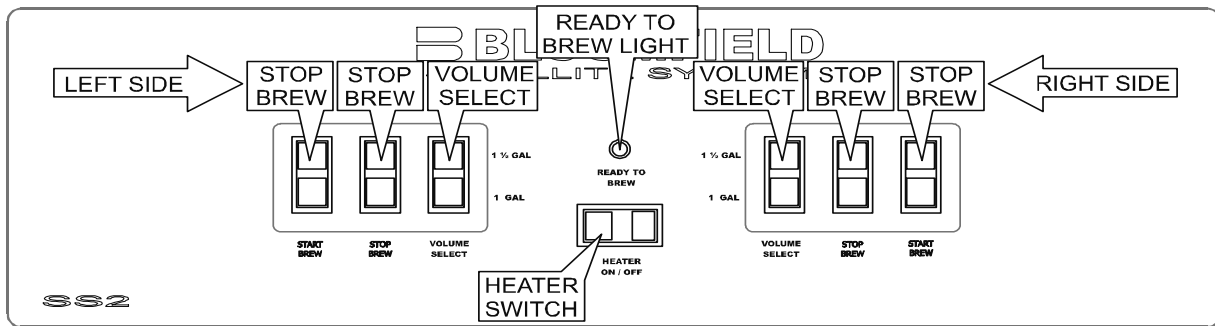

Fig. 4 Operating Controls

BREWING COFFEE

Prepare the Brew Baskets:

Make sure the wire rack is properly installed in each brew chamber.

Insert one (1) Bloomfield paper filter into each brew chamber. Make sure the filter is properly supported by the wire rack.

Add a measured amount of grounds to each brew basket. Gently shake the basket to level the grounds.

Slide one brew chamber under each brew head.

Insert Satellites:

Slide one satellite under each brew chamber until it is fully seated.

Press appropriate WARMER SWITCH to ON.

Select Brew Volume:

Press VOLUME SELECT switch to **1 GAL** or **1-1/2 GAL**.

Start the Brew:

Press either the right or left **START BREW** key.

NOTE: The brew can be cancelled at any time by pressing the **BREW STOP** key.

At the end of the brew, be sure all water has stopped dripping before removing the brew chamber.

When the READY-TO-BREW light comes on, the brewer is ready to run another brew cycle.

Empty the Brew Basket:

Discard the grounds and the paper filter. Rinse the brew chamber under clear water.

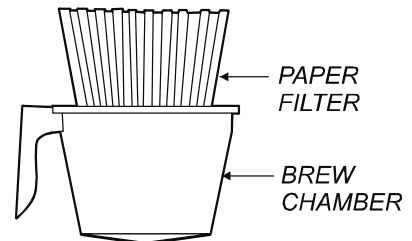

Fig. 5 Brew Basket



CAUTION:
BURN HAZARD

Basket and contents are hot to the touch and may cause burns on contact.



CLEANING INSTRUCTIONS



CAUTION: Burn Hazard

Brewing and serving temperatures of coffee are extremely hot. Hot coffee will cause serious skin burns.

PROCEDURE: Clean Coffee Brewer

PRECAUTIONS: Press POWER key to OFF.
Allow brewer to cool.

FREQUENCY: Daily

TOOLS: Mild Detergent, Clean Soft Cloth or Sponge
Bristle Brush

IMPORTANT:

DO NOT use steel wool, sharp objects, or caustic, abrasive or chlorinated cleansers to clean the brewer, brew baskets or satellites.

DO NOT immerse or submerge satellites in water.

1. Press POWER key to OFF.
Allow brewer to cool.
2. Remove satellites.
3. Remove and empty brew baskets.
4. Remove spray disks and gaskets from spray heads
5. Wipe inside of spray head and area around spray head with a soft clean cloth or sponge moistened with clean water.
6. Wash spray disks in a sink using warm water and a mild detergent. A bristle brush may be used to clear clogged spray holes. Rinse spray disks with clean water and allow to air dry.
7. Wash brew chambers in a sink using warm water and a mild detergent. Rinse with clean water and allow to air dry.
8. Remove and drain the drip tray. Rinse in a sink under warm running water. Allow to air dry, then reinstall on brewer.
9. Wipe exterior of brewer and satellites with a soft clean cloth or sponge moistened with clean water.
10. Reinstall gaskets INSIDE brew heads, then reinstall spray disks.
11. Reinstall brew chambers.
12. Reinstall satellites.

Procedure is complete

CLEANING INSTRUCTIONS (continued)

PROCEDURE: Clean Satellite

PRECAUTIONS: Drain Satellite before Cleaning

FREQUENCY: Twice Weekly

TOOLS: Sight Glass Brush, Sanitizer
Soft Clean Cloth, Bucket



CAUTION:
Burn Hazard

Brewing and serving temperatures of coffee are extremely hot. Hot coffee will cause serious skin burns.

1. Remove and drain satellites. Remove lids.
2. Place 1 packet of Sanitizer into 2-1/2 gallons of warm tap water. Pour approximately 1 gallon of sanitizer solution into each satellite. Allow to stand for 2 minutes.
3. Drain sanitizer solution from satellite into the bucket.
4. Disassemble faucet. Brush clean with sanitizer solution. Reassemble faucet.
5. If necessary, disassemble and clean sight glass.
 - a. Push down on ears on sight glass guard. Then, pull ears forward. Lift guard off of retaining clip.
 - b. Remove sight glass tube from silicone elbow. Run the sight glass brush through the tube at least ten times.
 - c. Reassemble the tube to the silicone elbow. Be sure the elbow has not been pulled from the satellite body.
 - d. Reinstall the sight glass guard.
6. Reinstall lids. Install satellites on brewer.
7. Rinse satellites: With an empty brew chamber in place, press the BREW key and run 1 full cycle into each satellite.
8. Drain water from satellites.

Procedure is complete

IMPORTANT:

DO NOT submerge satellite in water.

IMPORTANT:

DO NOT use steel wool, sharp objects, or caustic, abrasive or chlorinated cleansers to clean the satellites.

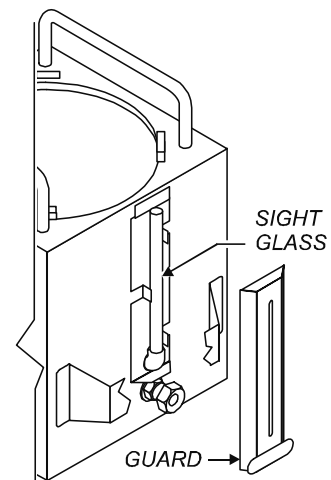

Sight Glass

SERVICING INSTRUCTIONS



CAUTION - CHEMICAL BURN HAZARD

Deliming chemicals are caustic. Wear appropriate protective gloves and goggles during this procedure.

Never siphon deliming chemicals or solutions by mouth.

This operation should only be performed by qualified and experienced service personnel.

IMPORTANT: DO NOT spill, splash or pour water or deliming solution into or over any internal component other than the inside of the water tank.

IMPORTANT: DO NOT allow any internal components to come into contact with the deliming solution. Take care to keep all internal components dry.

NOTE: Repeat steps 4 and 7 as required to remove all build-up.

PROCEDURE: Delime the Water Tank

PRECAUTIONS: Disconnect brewer from electric power. Allow brewer to cool.

FREQUENCY: As required (Brewer slow to heat)

TOOLS: Deliming Solution
Protective Gloves, Goggles & Apron
Mild Detergent, Clean Soft Cloth or Sponge
Bristle Brush, Bottle Brush
Large Sink (or other appropriate work area)

-
1. Disconnect brewer from the electrical supply.
 2. Remove the brewer top panel, then remove the tank lid assembly. Do not disconnect the tank assembly at this time.
 3. Siphon all water from the hot water tank.
 4. Mix 10 gallons of deliming solution according to the manufacturer's directions. Carefully pour the deliming solution into the water tank. Lower the lid assembly back onto the tank. Allow to sit for 30 minutes, or as directed by the chemical manufacturer.
 5. At end of soaking period, reconnect brewer to electrical power. Install the brew chamber without filter paper or grounds. Place an empty satellite under the brew chamber. Force a 1-1/2 gallon brew:
 - a. Press the 1-1/2 gallon key
 - b. Press the brew key, then press and hold the brew key until a brew is initiated.Empty the satellite and repeat for the other side.
 6. Disconnect brewer from electrical power and allow to cool.
 7. Remove lid assembly from tank.
 - a. Using a stiff bristle brush, scrub internal components to remove lime and calcium build-up.
 - b. Thoroughly rinse internal components of lid assembly with clear water.
 - c. Store lid assembly in a safe location.
 8. Using a stiff bristle brush, scrub exposed portions of the heating element and the inside surfaces of the tank to remove lime and calcium build-up.
 9. Siphon all solution from the tank.

SERVICING INSTRUCTIONS (continued)

10. Reinstall tank lid assembly into hot water tank. Make sure the lid gasket is properly in place, then reinstall the hold-down clamps.
11. Remove spray disks and gaskets. Rinse both brew heads with clean water. Using a stiff brush, scrub spray disk to remove any lime or calcium build-up. Reinstall gaskets and spray disks.
13. Reconnect brewer to electrical supply .
14. Install the brew chamber without filter paper or grounds.
15. Place an empty satellite under the brew chamber. Run at least five 1-1/2 gallon brew cycles and discard all water generated at the end of each cycle. Repeat for the other side.
16. Rinse satellite with clean water. Reinstall one empty satellite under each brew chamber.

NOTE: Normally, silicone hoses do not need to be delimed. Should deliming hoses become necessary, Bloomfield recommends replacing the hoses.

Brewer is ready to use.

SERVICING INSTRUCTIONS (continued)

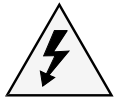

CAUTION: SHOCK HAZARD

Disconnect brewer from electric power before opening the access panel.

Adjustments to be performed by qualified technician only.

NOTE:

Brewer is pre-adjusted to deliver 1 and 1-1/2 gallons of coffee at a water pressure of 50 p.s.i. Use this procedure to adjust the delivered volume to suit local conditions.

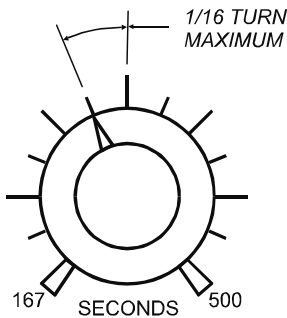

TIMER ADJUSTMENT

PRECAUTIONS: Disconnect brewer from electric power.
Allow brewer to cool.

FREQUENCY: As required to adjust delivered volume

TOOLS: Phillips head screwdriver
Satellite or other container to calibrate volume

1. Press HEATER ON/OFF switch to *OFF*. Turn POWER switch on back of brewer *OFF*.
2. Remove TOP PANEL. Operating controls are accessible through the top panel only.
3. Adjust the TIMER setting.
NOTE: Each side has its own timer. The LEFT TIMER is for the LEFT SIDE; the RIGHT TIMER is for the RIGHT SIDE.
Turn *CLOCKWISE* to increase time;
Turn *COUNTER-CLOCKWISE* to decrease time.
Adjust only in small increments to avoid large volume variations. Recommend no more than 1/16 turn.
4. Replace TOP PANEL. Turn POWER switch *ON*. Press HEATER ON/OFF switch to *ON*.
5. Allow the brewer to come up to brewing temperature, then perform a test brew. Check delivered volume. Readjust as necessary.

When desired volume is achieved, procedure is complete.

SERVICING INSTRUCTIONS (continued)

TEMPERATURE ADJUSTMENT

PRECAUTIONS: Disconnect brewer from electric power.
Allow brewer to cool.

FREQUENCY: As required to adjust delivered volume

TOOLS: Phillips head screwdriver
Satellite or other container to calibrate volume

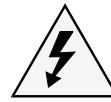

CAUTION:
SHOCK HAZARD

Live electrical circuits are exposed during this procedure. Use care to avoid uninsulated electrical connectors.

Adjustments to be performed by qualified technician only.

NOTE:

1/8 turn = approx 10°F (5.5°C)

1. Press HEATER ON/OFF switch to *OFF*. Turn POWER switch on back of brewer *OFF*.
2. Remove TOP PANEL. Operating controls are accessible through the top panel only.
3. Remove one of the plugs in the tank cover and insert a thermometer of known accuracy.
4. Locate the CONTROL THERMOSTAT on the right side of the top housing:
Turn *CLOCKWISE* to increase temperature
Turn *COUNTER-CLOCKWISE* to decrease temperature
1/8 turn is equal to approximately 10°F change.
5. Turn POWER switch *ON*. Press HEATER ON/OFF switch to *ON*.
6. Allow the brewer to come up to brewing temperature. When *READY-TO-BREW* light comes on, check temperature on thermometer. Readjust thermostat as necessary.

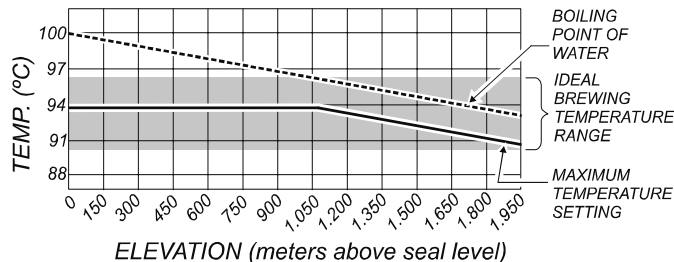
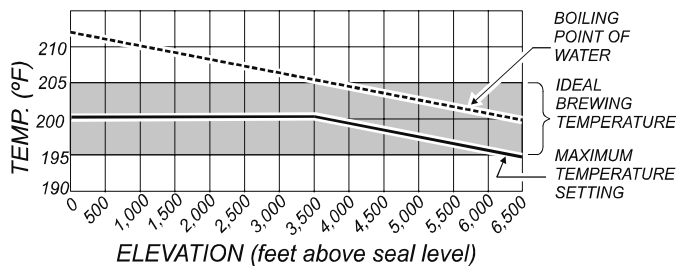
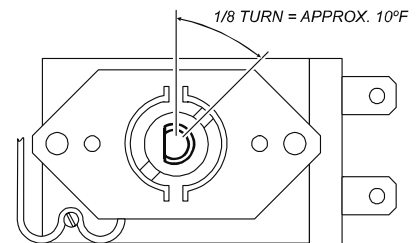

7. When desired temperature is achieved, remove thermometer, replace tank plug and reinstall top panel.

Procedure is complete

TROUBLESHOOTING SUGGESTIONS

DESCRIPTION OF PROBLEM	POSSIBLE CAUSE	SUGGESTED REMEDY
No lights or heat	Unit not plugged in or circuit breaker tripped	Restore electric power
No heat	Power switch OFF	Turn power switch ON
	Hi-limit safety tripped	Allow brewer to cool, verify water level, reset hi-limit
	Thermostat damaged	Replace thermostat
	Damaged hi-limit safety	Replace hi-limit
	Damaged heater switch	Replace heater switch
	Damaged heating element	Replace heating element
Brewer overflows	Water level probe corroded	Clean water level probe
	Poor ground connection	Verify ground connection
	Dirt in inlet valve or valve damaged	Replace inlet valve
	Brew valve damaged	Replace brew valve
	Tank water boiling	Adjust or replace thermostat
Brew chamber overflows	Too many paper filters or wrong filter used.	Use one genuine Bloomfield paper filter per brew
	Chamber discharge hole plugged	Clean brew chamber
	Timer not set properly	Set timer
	Too much coffee or too fine a grind	Check with coffee supplier for recommended grind and quantity
Heats slow	Connected to wrong voltage	Verify supply voltage
	Scale build-up on heating elements	De-lime hot water tank
	Damaged heating element	Replace element
Slow to fill	Insufficient water pressure	Brewer must be operated on a dedicated water line. Other equipment on line may be robbing water volume.
	Plugged water line strainer	Clean strainer
No heat to satellite	Warmer switch not on	Turn warmer switch on
	Damaged element or wiring	Replace as required
Poor coffee quality	Keep brewer and servers clean. Install a taste and odor filter in water supply, and replace cartridges regularly. Use a quality coffee with a consistent roast. Use proper grind and amount of coffee per brew.	

SATELLITE EXPLODED VIEW & PARTS LIST

SATELLITE MODEL 9440

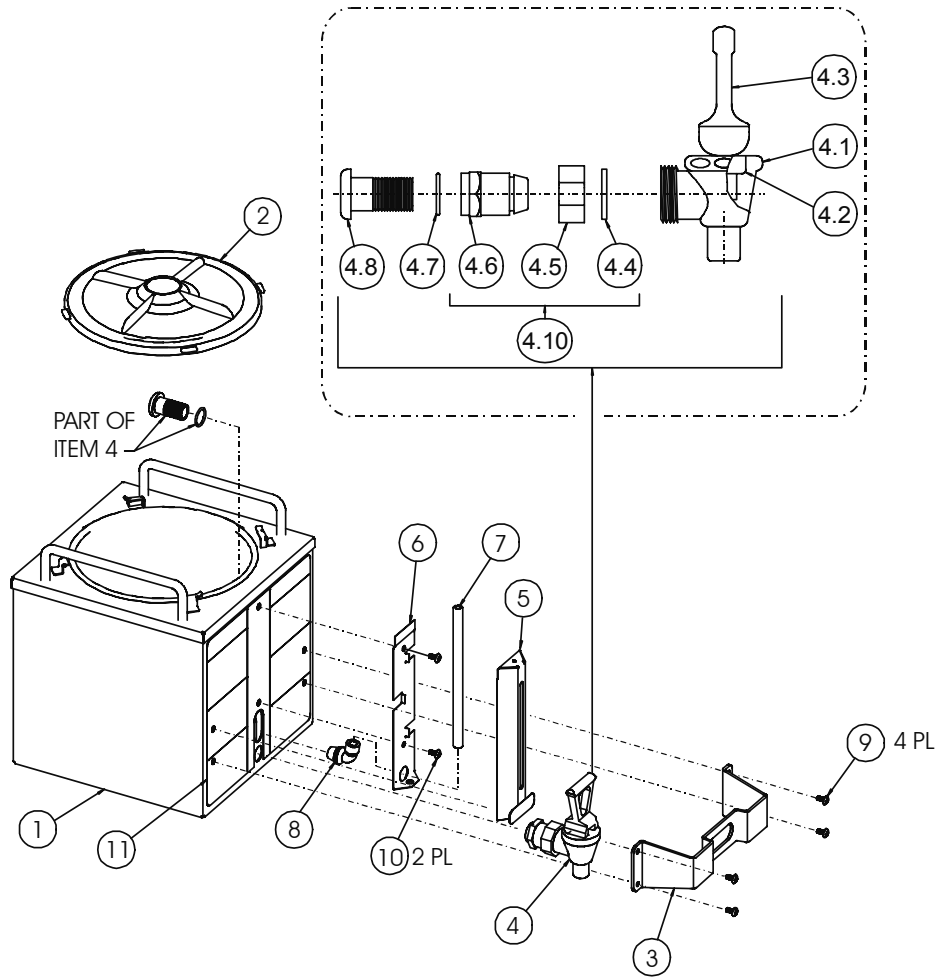

ITEM	PART NO.	DESCRIPTION	QTY
1		WELDMNT, SATELLITE	1
2	83863	TANK LID ASSY	1
3	84313	HANDLE / FAUCET GUARD	1
4	86577	FAUCET & SHANK ASSY	1
4.1	86600	FAUCET, MODEL ESP	1
4.2	8700-25L	SEAT CUP, #3S10	1
4.3	84392	HANDLE, #13SBE-SNAP	1
4.4	84394	C-RING #18-1	1
4.5	8600-26	NUT HEX	1
4.6	84395	SHANK	1
4.7	84489	WASHER, FIBRE	1
4.8	84488	FERRULE	1
4.10	84396	SHANK ASSY	1
5	84299	HOUSING, SIGHT GAUGE	1
6	84300	BRACKET, SIGHT GAUGE	1
7	84354	TUBE, SIGHT GAUGE	1
8	8043-13	ELBOW	1
9		SCREW, 8A x 1/2 TRS HD ST BLK	4
10		SCREW, 8A x 1/2 TRS HD ST SS	2
11		DECAL, SATELLITE	1

EXPLODED VIEW CABINET AND EXTERIOR COMPONENTS

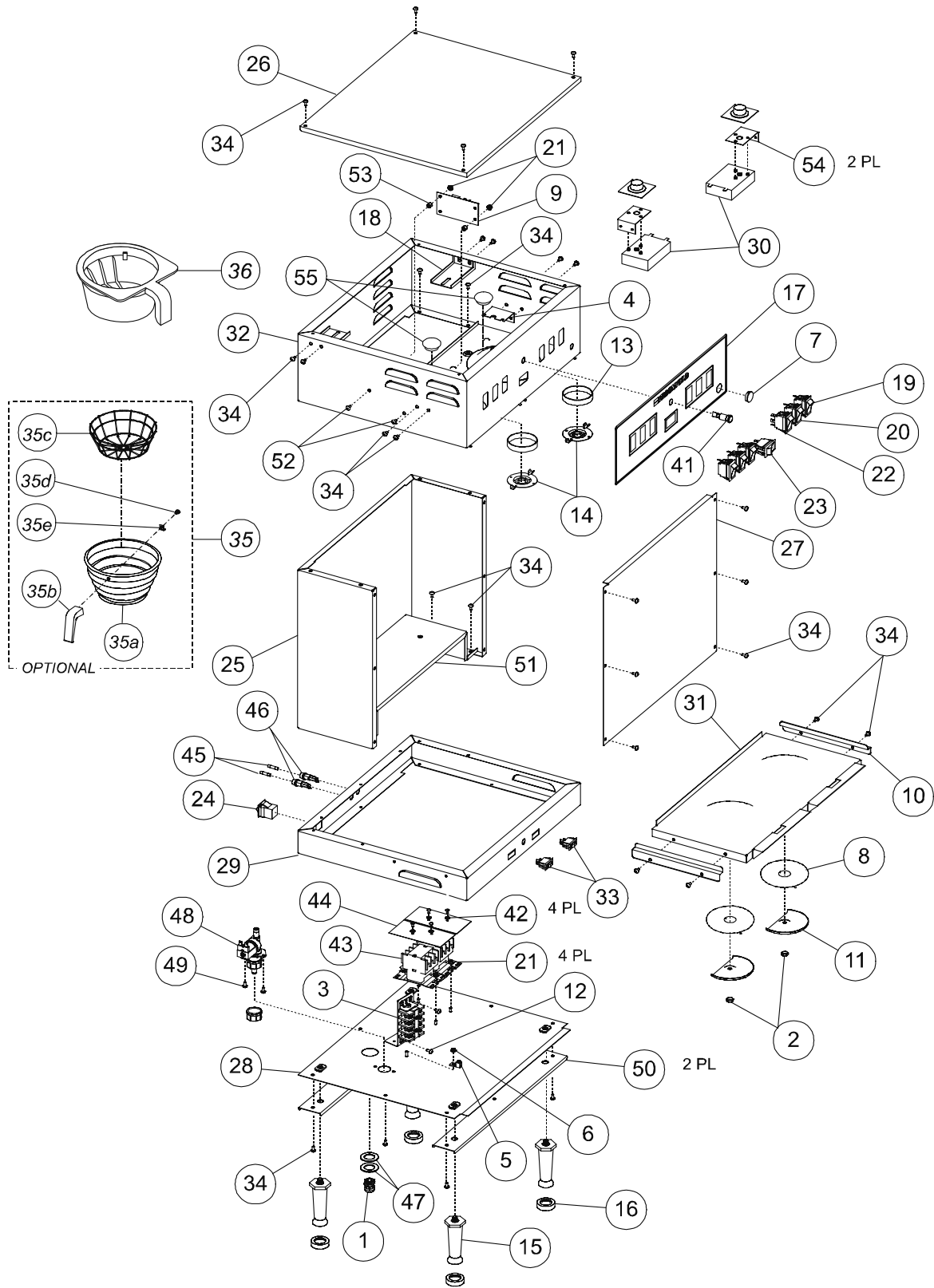

PARTS LIST CABINET AND EXTERIOR COMPONENTS

ITEM	P/N	DESCRIPTION	QTY	ITEM	P/N	DESCRIPTION	QTY
1	9012-38	STRAIN RELIEF	1	31		WARMER BASE	1
2	55485	NUT HEX 1/4-20 SS	2	32		HOUSING UPPER ASSY	1
3	60310	TERMINAL BLOCK 3P	1	33	84382	SWITCH ROCKER HI-TEMP	2
4		BRACKET THERMOSTAT	1	34		SCREW 8A x 1/2 TR TAP SS	40
5		LUG GROUND SOLDERLESS	1	35	82533	BREW CHAMBER ASSY (SS)	O P T I O N A L
6	55736	NUT KEP 8-32 GREEN	1	35a	32387	BREW CHAMBER ONLY	
7	85235	BUTTON PLUG BLK PLASTIC	1	35b	8707-2	HANDLE BREW CHAMBER BLK	
8	8533-32	ELEMENT WARMER 240V 100W	2	35c	8706-9	WIRE RACK BREW CHAMBER	
9	503141	CONTROL BOARD LIQ LEVEL	1	35d	8707-3	SCREW BREW CHAMBER	
10		GUIDE, SATELLITE	2	35e	8812-73	CLIP BREW CHAMBER	
11	8703-26	RETAINER WARMER ELEMENT	2	36	86652	BREW CHAMBER ASSY (PLASTIC)	2
12	7200-6X	SCREW 8-32 x 5/16 PHL SS	2	41	8738-2	LIGHT PILOT GREEN 250V	1
13	82215	GASKET SPRAYHEAD 1.5 ID	2	42		WASHER FLAT #4	4
14	82727	DISK SPRAY HEAD EMBOSSED	2	43	57780	CONTACTOR 3P 240V 40A	2
15	83098	LEG 4" BLK PLASTIC	4	44	83885	DRIP SHIELD	2
16	83107	FEET RUBBER BLK	4	45	83794	FUSE 5A	2
17	84604	DECAL CONTROL PANEL	1	46	83795	FUSE HOLDER	2
18		BRACKET TOP TANK SUPPORT	2	47	83793	WASHER 1.50 O.D.	2
19	84620	SWITCH LIGHTED OFF MOM ON	2	48	85760	SOLENOID SINGLE 240V 1.0 GPM	1
20	84621	SWITCH 2P ON MOM OFF 10A	2	49		SCREW PAN 4mm x 6mm SS	2
21		NUT KEP 8-32 SS	6	50		STIFFENER, BOTTOM PLATE	2
22	84622	SWITCH 2P ON NONE ON 10A	2	51		TANK SUPPORT	1
23	82395	SWITCH LIGHTED 20A 250V	1	52	7506-39	SCREW 8-32 x 1/2 PH SS	2
24	82936	SWITCH ROCKER ON-OFF	1	53	83362	SPACER .17 I.D. x 1/4 LG	2
25		LOWER HOUSING	1	54		BRACKET, TIMER	2
26		COVER TOP HOUSING	1	55	83319	PLUG, REMOVE BYPASS	2
27		FRONT PANEL	1				
28		PLATE BOTTOM ASSY	1				
29		BASE WRAP	1				
30	85123	TIMER FULL, 2/3, 1/3 230V	2				

EXPLODED VIEW INTERIOR COMPONENTS

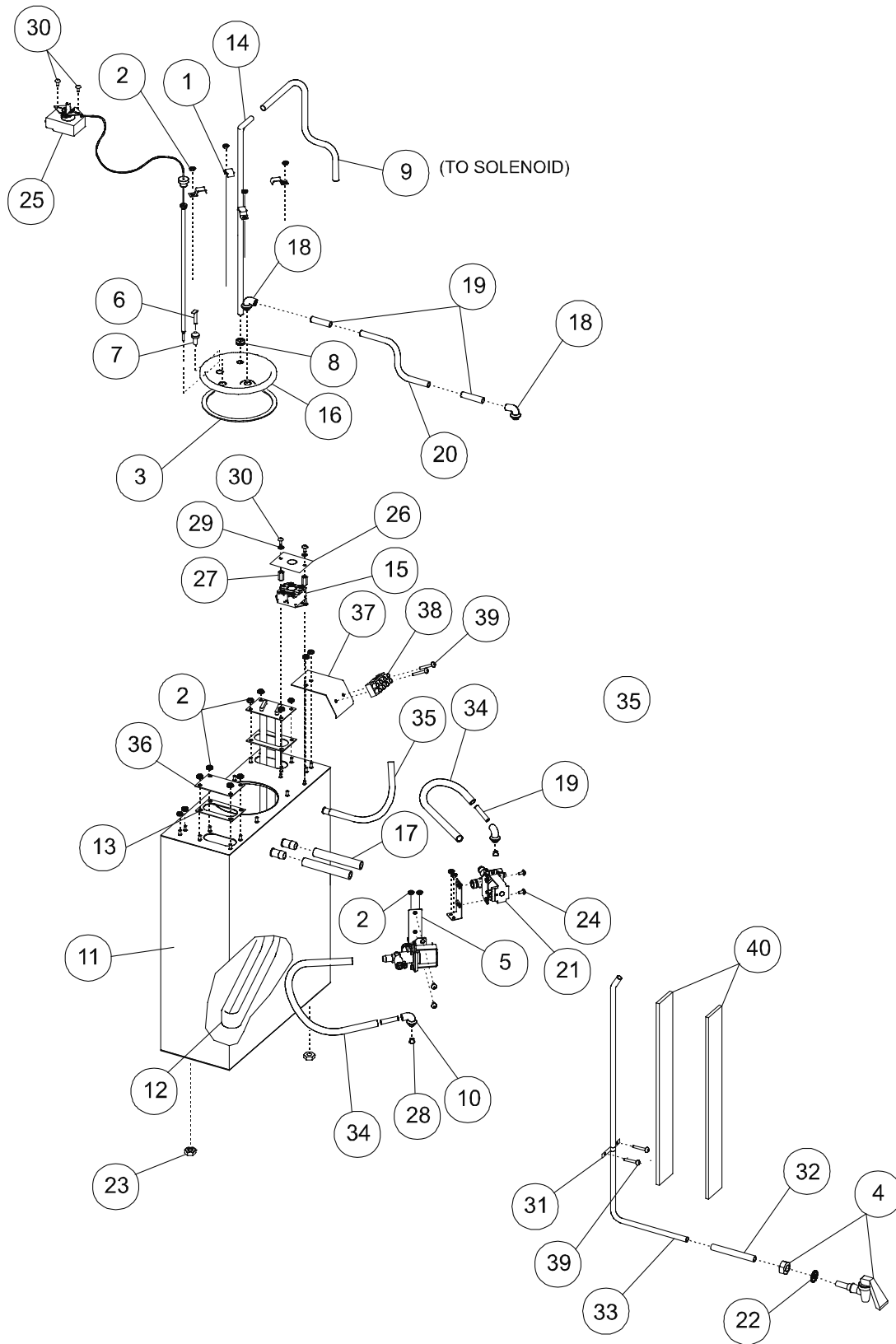

PARTS LIST INTERIOR COMPONENTS

ITEM	P/N	DESCRIPTION	QTY	ITEM	P/N	DESCRIPTION	QTY
1	83778	RETAINING CLIP TANK LID	4	21	84619	VALVE DISPENSING ADJUST	2
2		NUT KEPS 8-32 SS	20	22	82148	LOCK WASHER	1
3	8043-12	GASKET TANK COVER	1	23	55485	NUT 1/4-20 (pk 100)	1
4	8783-1	FAUCET HOT WATER	1	24		SCREW 8A x 1/2 TR TAP SS	4
5		BRACKET OUTLET VALVE	2	25	86280	THERMOSTAT 15" CAP TUBE	1
6	83521	PROBE ASSY WATER LEVEL	1	26	83414	SHIELD HI-LIMIT THERMO	1
7	83532	SLEEVE WATER LEVEL PROBE	1	27	83415	NUT 6-32 x 1" LG	2
8	82390	GROMMET .312 ID	1	28	83571	INSERT SPRAY HEAD SS2	2
9	83978	TUBE SILICONE .312 x 30"	1	29		WASHER FLAT #8 SS	2
10	83152	ELBOW SPRAYER	2	30	3-100	SCREW 6-32 x 1/4 SS	4
11		TANK ASSY	1	31	85289	STRAP, TIE-DOWN	1
12	84923	ELEMENT 3000W 240V	2	32	85204	TUBE, SILICONE .312 ID x 3"	1
13	83309	GASKET TANK HEATER	2	33	84434	TUBE FORMED SS	1
14	84343	FILL TUBE 90° BEND	1	34	84715	TUBE SILICONE .312 ID x 11"	2
15	83312	THERMOSTAT HI-LIMIT 2P	1	35	83538	TUBE SILICONE .312 ID x 10"	1
16		TANK LID ASSY	1	36		BLANKING PLATE	1
17	84630	TUBE SILICONE .50 ID x 4.25	2	37		BRACKET TERMINAL BLOCK	1
18	8043-11	ELBOW OUTLET	2	38	8552-18	TERMINAL BLOCK	1
19	83384	TUBE VENT EXTENSION	4	39	616-5	SCREW 6-32 x 3/4	4
20	83537	TUBE SILICONE 9"	1	40	84435	INSULATION, FAUCET TUBE	2

WIRING DIAGRAM

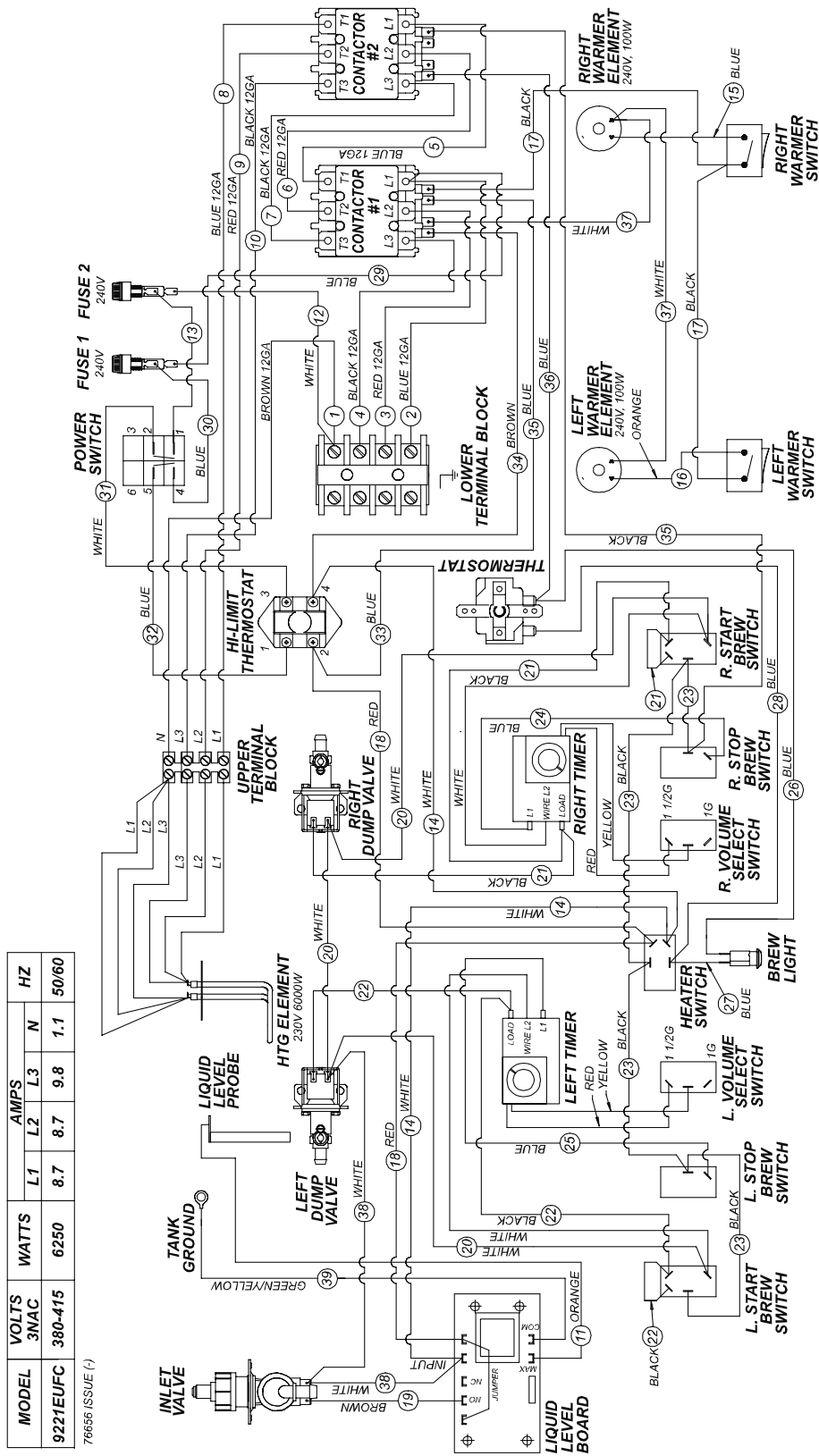

WATER FLOW DIAGRAM

WATER FLOW

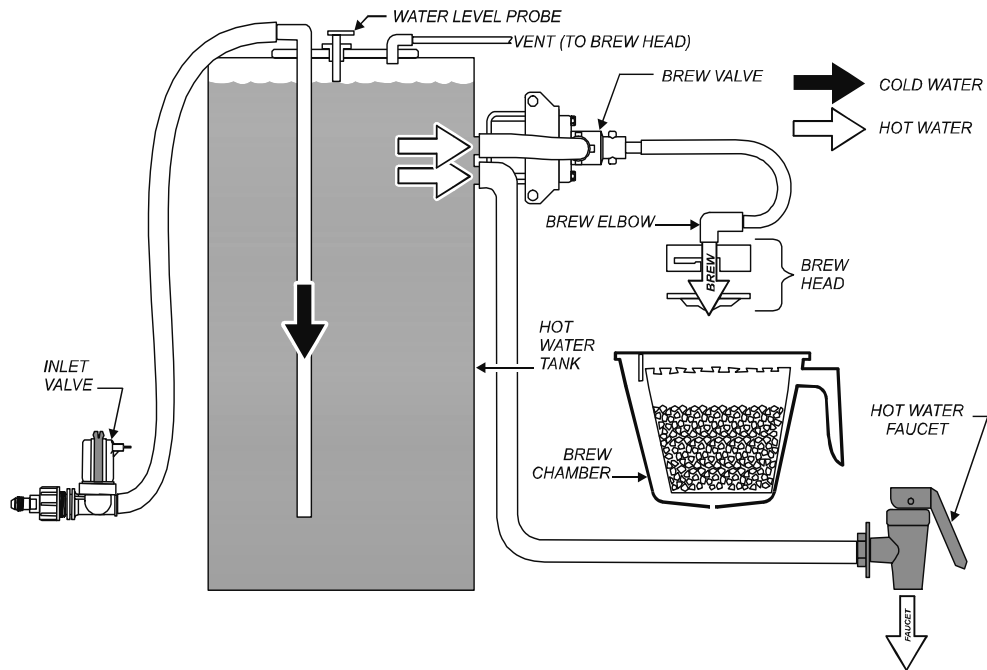

INLET

The INLET VALVE is controlled by a signal from the CONTROL BOARD. If the WATER LEVEL PROBE does not detect water, the inlet solenoid is opened until water is again sensed.

BREW

The BREW VALVE is fed by gravity from the hot water tank.

The brew valve is opened for a length of time as determined by the TIMER setting.

The brew water is discharged through the SPRAY DISK and flows over the grounds in the brew basket.

Each half of the brewer is independently controlled.

HOT WATER FAUCET

The HOT WATER FAUCET is fed by gravity from the hot water tank. The faucet is spring-loaded closed and manually opened.

The 9221-Series of brewers have two independent brewing systems sharing a common hot water tank.

The hot water faucet is fed by the hot water tank, but is otherwise independent of the brewing systems.

NOTE:

Use of the hot water faucet during a brew cycle will not change the delivered volume. However, excessive use of the faucet during brew may lower the brew water temperature.

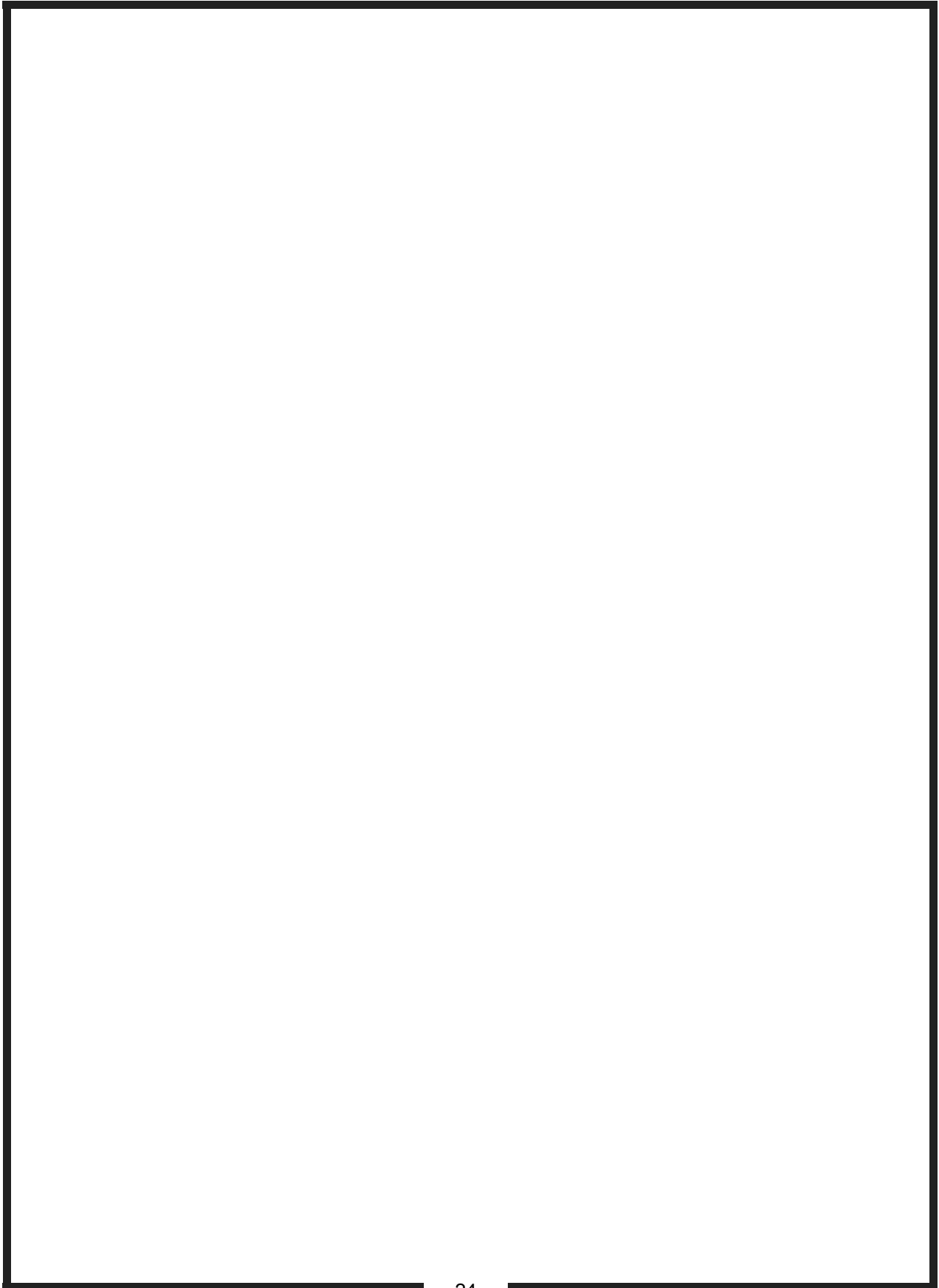

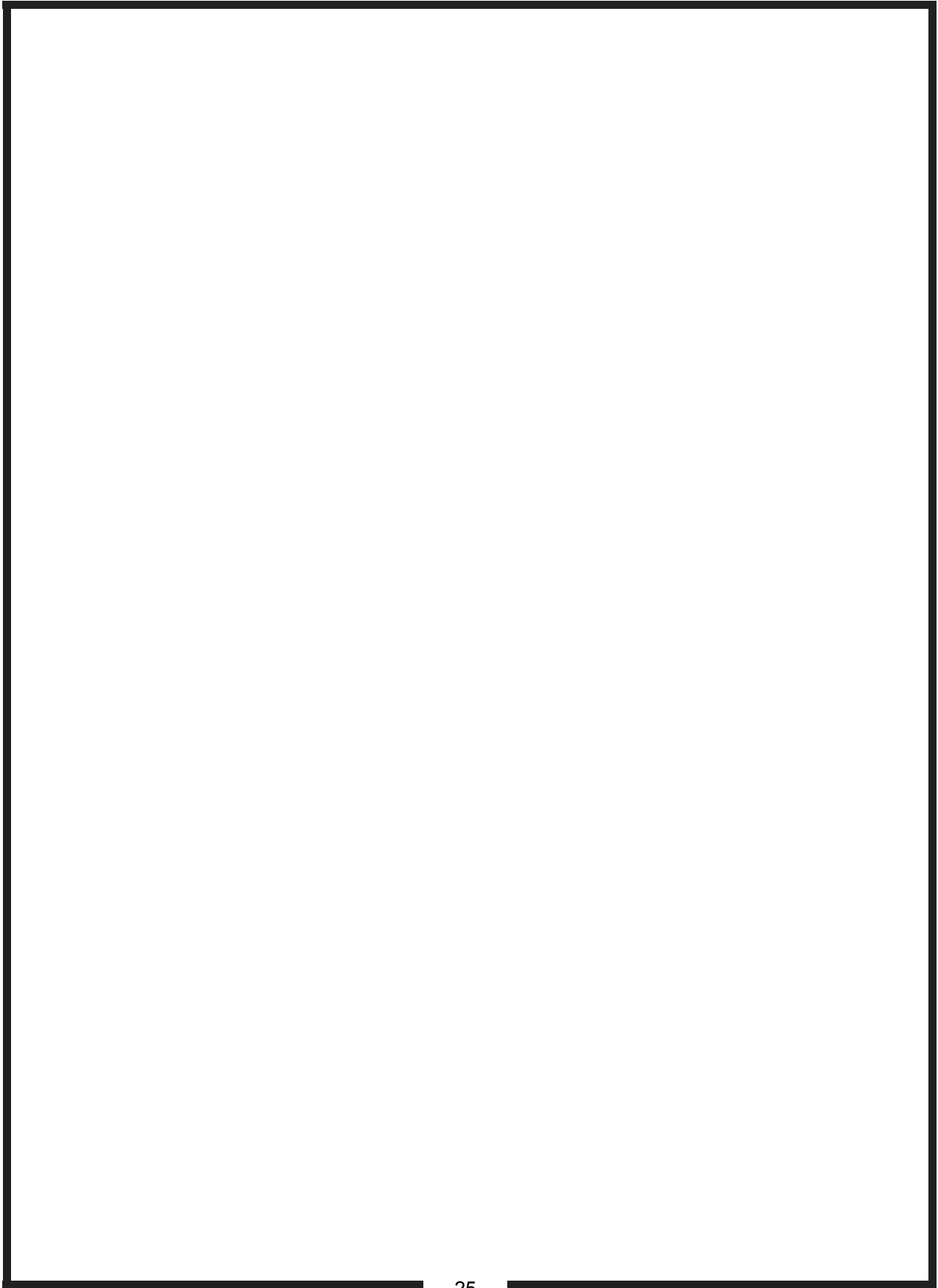

CFESA

Commercial Food Equipment Service Association

Bloomfield Industries proudly supports CFESA
Commercial Food Equipment Service Association

SERVICE TRAINING - QUALITY SERVICE



CUSTOMER SATISFACTION

BLOOMFIELD

WELLS BLOOMFIELD, LLC

265 Hobson St. Smithville, TN 37166
telephone: 314-678-6336 fax: 314-781-2714
www.wellsbloomfield.com