

BLOOMFIELD INDUSTRIES

2 ERIK CIRCLE, P. O. Box 280
Verdi, NV 89439
telephone: 775-689-5700
fax: 888-492-2783
www.wellsbloomfield.com



Model: 9600 Single Cup Brewer

**OWNERS MANUAL
For****COFFEE BREWERS**

**MODELS:
9600 SINGLE CUP**

**INCLUDES:
Installation
Operation
Use & Care
Servicing Instructions**

PRINTED IN CHINA

WARRANTY STATEMENT

All electrical equipment manufactured by BLOOMFIELD INDUSTRIES is warranted against defects in materials and workmanship for a period of one year from the date of original installation or eighteen (18) months from the date of shipment from our factory, whichever comes first, and is for the benefit of the original purchaser, except that:

- a. airpots carry a 30 day parts warranty only.
- b. dispensers; i.e., tea and coffee carry a 90 days parts warranty only, excludes decanters.

THE FOREGOING OBLIGATION IS EXPRESSLY GIVEN IN LIEU OF ANY OTHER WARRANTIES, EXPRESSED OR IMPLIED, INCLUDING ANY IMPLIED WARRANTY OF MERCHANTABILITY OR FITNESS FOR A PARTICULAR PURPOSE, WHICH ARE HEREBY EXCLUDED.

BLOOMFIELD INDUSTRIES DIVISION / SPECIALTY EQUIPMENT MANUFACTURING CORPORATION SHALL NOT BE LIABLE FOR INDIRECT, INCIDENTAL OR CONSEQUENTIAL DAMAGES OR LOSSES FROM ANY CAUSE WHATSOEVER.

This warranty is void if it is determined that upon inspection by an Authorized Service Agency that the equipment has been modified, misused, misapplied, improperly installed, or damaged in transit or by fire, flood or act of God.

It also does not apply if the serial nameplate has been removed or unauthorized service personnel perform service. The prices charged by Bloomfield Industries for its products are based upon the limitations in this warranty. Seller's obligation under this warranty is limited to the repair of defects without charge by a Bloomfield Industries Authorized Service Agency or one of its sub-agencies. This service will be provided on customer's premises for non-portable models. Portable models (a device with a cord and plug) must be taken or shipped to the closest Authorized Service Agency, transportation charges prepaid, for services.

In addition to restrictions contained in this warranty, specific limitations are shown below (Additional Warranty Exclusions). Bloomfield Industries Authorized Service Agencies are located in principal cities.

This warranty is valid in the United States and void elsewhere. Please consult your classified telephone directory or your food service equipment dealer; or, for information and other details concerning warranty, write to:

**Service Parts Department
Bloomfield Industries
P.O. Box 280
Verdi, NV 89439**

Phone: (775) 689-5700

Fax: (888) 492-2783

SERVICE POLICY AND PROCEDURE GUIDE ADDITIONAL WARRANTY EXCLUSIONS

1. Resetting of safety thermostats, circuit breakers, overload protectors, or fuse replacements unless warranted conditions are the cause.
2. All problems due to operation at voltages other than specified on equipment nameplates; conversion to correct voltage must be the customer's responsibility.
3. All problems due to electrical connections not made in accordance with electrical code requirements and wiring diagrams supplied with the equipment.
4. Replacement of items subject to normal wear, to include such items as knobs and light bulbs. Normal maintenance functions including adjustment of thermostats, microswitches, and replacement of fuses and indicating lights are not covered under warranty.
5. All problems due to inadequate water supply, such as fluctuating, or high or low water pressure.
6. All problems due to mineral/calcium deposits, or contamination from chlorides/chlorines. De-liming is considered a preventative maintenance function and is not covered by warranty.
7. Full use, care and maintenance instructions are supplied with each machine. Those miscellaneous adjustments noted are customer responsibility. Proper attention will prolong the life of the machine.
8. Travel mileage is limited to sixty (60) miles from an authorized Service Agency or one of its sub-agencies.
9. All labor shall be performed during normal working hours. Overtime premium shall be charged to the customer.
10. All genuine Bloomfield replacement parts are warranted for ninety (90) days from date of purchase on non-warranted equipment. **Any use of non-genuine Bloomfield parts completely voids any warranty.**
11. Installation, labor and job check-out are not considered warranty.
12. Charges incurred by delays, waiting time or operating restrictions that hinder the service technicians ability to perform services are not covered by warranty. This includes institutional and correctional facilities.

SHIPPING DAMAGE CLAIMS PROCEDURE

NOTE: For your protection, please note that equipment in this shipment was carefully inspected and packaged by skilled personnel before leaving the factory. Upon acceptance of this shipment, the transportation company assumes full responsibility for its safe delivery.

IF SHIPMENT ARRIVES DAMAGED:

1. **VISIBLE LOSS OR DAMAGE:** Be certain that any visible loss or damage is noted on the freight bill or express receipt, and that the note of loss or damage is signed by the delivery person.
2. **FILE CLAIM FOR DAMAGE IMMEDIATELY:** Regardless of the extent of the damage.

3. **CONCEALED LOSS OR DAMAGE:** if damage is unnoticed until the merchandise is unpacked, notify the transportation company or carrier immediately, and file "CONCEALED DAMAGE" claim with them. This must be done within fifteen (15) days from the date the delivery was made to you. Be sure to retain the container for inspection.

Bloomfield Industries cannot assume liability for damage or loss incurred in transit. We will, however, at your request, supply you with the necessary documents to support your claim.

TABLE OF CONTENTS

WARRANTY STATEMENT	xi	Thank You for purchasing this Bloomfield Industries appliance.
SPECIFICATIONS	1	
FEATURES & OPERATING CONTROLS	2	
PRECAUTIONS & GENERAL INFORMATION	3	Proper installation, professional operation and consistent maintenance of this appliance will ensure that it gives you the very best performance and a long, economical service life.
AGENCY LISTING INFORMATION	3	
INSTALLATION INSTRUCTIONS	4	
OPERATION	7	
Program Volume Select Keys	8	
Brew Coffee	9	
CLEANING INSTRUCTIONS	10	This manual contains the information needed to properly install this appliance, and to use, care for and maintain or repair the appliance in a manner which will ensure its optimum performance.
TROUBLESHOOTING SUGGESTIONS	11	
SERVICING INSTRUCTIONS	12	
Deliming Instructions	17	
EXPLODED VIEW & PARTS LIST	18	
WIRING DIAGRAMS	21	

SPECIFICATIONS

MODEL	STYLE	FEATURES	VOLTS	WATTS	AMPS 1ø	POWER SUPPLY CORD
9600	SINGLE CUP COFFEE BREWER	HOT WATER DISPENSER	120 VAC	1500	12.5	NEMA 5-15P

APPLICABILITY

This manual applies to the following Bloomfield Industries product:
9600, 9600CA

FEATURES AND OPERATING CONTROLS - AUTOMATIC BREWERS

MODEL 9600

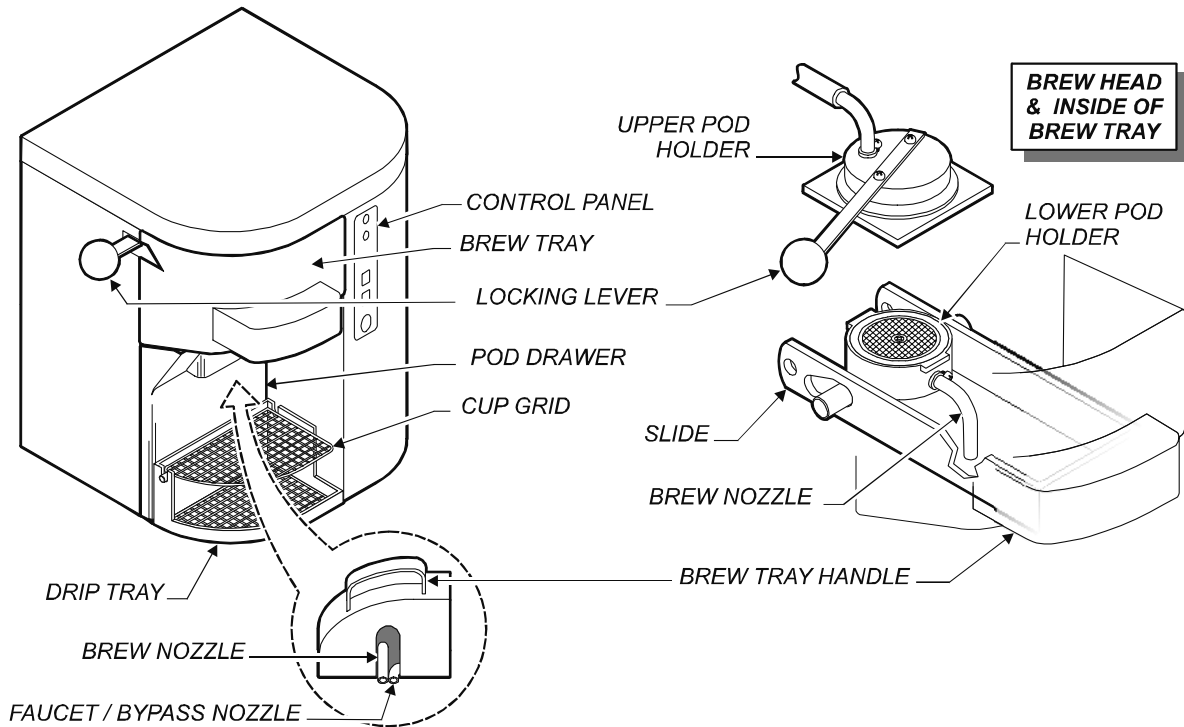

REAR VIEW

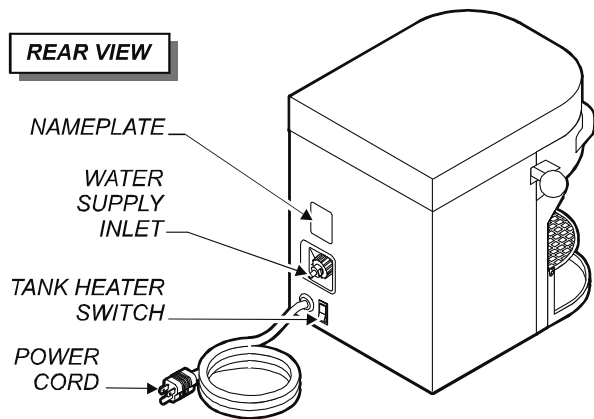

CONTROL PANEL

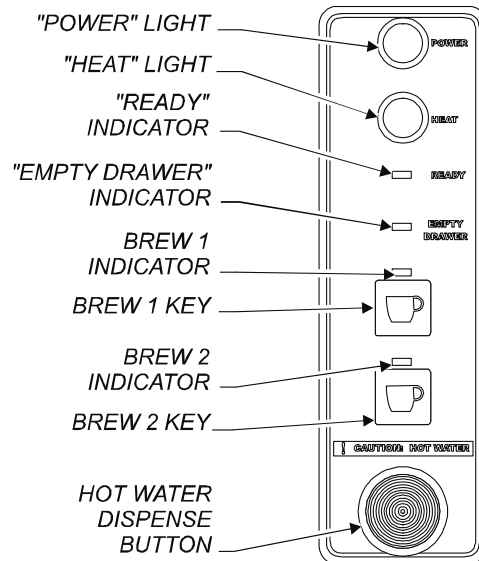

Fig. 1 Features & Operating Controls for Single Cup Brewers

PRECAUTIONS AND GENERAL INFORMATION



WARNING: ELECTRIC SHOCK HAZARD

All servicing requiring access to non-insulated components must be performed by qualified service personnel. Do not open any access panels which require the use of tools. Failure to heed this warning can result in electrical shock.



WARNING: INJURY HAZARD

All installation procedures must be performed by qualified personnel with full knowledge of all applicable electrical and plumbing codes. Failure could result in property damage and personal injury.



WARNING: ELECTRIC SHOCK HAZARD

Brewer must be properly grounded to prevent possible shock hazard. DO NOT assume a plumbing line will provide such a ground. Electrical shock will cause death or serious injury.



WARNING: BURN HAZARD

This appliance dispenses very hot liquid. Serious bodily injury from scalding can occur from contact with dispensed liquids.

This appliance is intended for commercial use only.

This appliance is intended for use to brew beverage products for human consumption. No other use is recommended or authorized by the manufacturer or its agents.

This appliance is intended for use in commercial establishments, where all operators are familiar with the appliance use, limitations and associated hazards. Operating instructions and warnings must be read and understood by all operators and users.

The following trouble shooting, component views and parts lists are included for general reference, and are intended for use by qualified service personnel.

This manual should be considered a permanent part of this appliance. The manual must remain with the appliance if it is sold or moved to another location.



CAUTION: ELECTRICAL DAMAGE

DO NOT plug in or energize this appliance until all *Installation Instructions* are read and followed. Damage to the Brewer will occur if these instructions are not followed.



CAUTION: BURN HAZARD

Exposed surfaces of the appliance may be HOT to the touch, and can cause serious burns.

AGENCY LISTING INFORMATION

This brewer is  and  listed under UL file E9253.

This brewer meets  Standard 4 only when installed, operated and maintained in accordance with the enclosed instructions.



E9253



E9253



STD 4

INSTALLATION

READ THIS CAREFULLY BEFORE STARTING THE INSTALLATION

IMPORTANT:

To enable the installer to make a quality installation and to minimize installation time, the following suggestions and tests should be done before the actual unit installation is started:



CAUTION: ELECTRICAL DAMAGE

DO NOT plug in or energize this appliance until all Installation Instructions are read and followed. Damage to the Brewer will occur if these instructions are not followed.



CAUTION: UNSTABLE EQUIPMENT HAZARD

It is very important for safety and for proper operation that the brewer is level and stable when standing in its final operating position. Provided adjustable, feet or legs must be installed at each corner of the unit. Failure to do so will result in movement of the brewer which can cause personal injury and/or damage to brewer.

Unpack the unit. Inspect all components for completeness and condition. Ensure that all packing materials have been removed from the unit.

LEVELING THE UNIT

Verify that an adjustable leg is installed at each of the five locations on the bottom of the brewer.

Set Brewer in its operating location. Level the Brewer. A spirit level should be placed on the top of the unit, at the edge, as a guide when making level adjustments.

Level the unit from left to right and front to back by turning the adjustable feet. Be sure all feet touch the counter to prevent tipping.

INSTALLATION (continued)

PLUMBER'S INSTALLATION INSTRUCTIONS

Brewer should be connected to a **POTABLE WATER, COLD WATER** line. Flush water line before connecting to Brewer.

DO NOT use a saddle valve with a self-piercing tap for the water line connection. Such a tap can become restricted by waterline debris. For systems that must use a saddle tap, shut off the main water supply and drill a 3/16" (minimum) tap for the saddle connection, in order to insure an ample water supply. Remember to flush the line prior to installing the saddle.

The brewer must be installed on a water line with average pressure between 20 PSI and 90 PSI. If your water pressure exceeds 90 PSI at anytime, a pressure regulator must be installed in the water supply line to limit the pressure to not more than 90 PSI in order to avoid damage to lines and solenoid.

A water shut-off valve should be installed on the incoming water line in a convenient location (Use a low restriction type valve, such as a 1/4-turn ball valve, to avoid loss of water flow thru the valve).

NSF requires that the brewer be able to be moved for cleaning underneath. Loops of copper tubing will satisfy this requirement. See Figure 2 below.

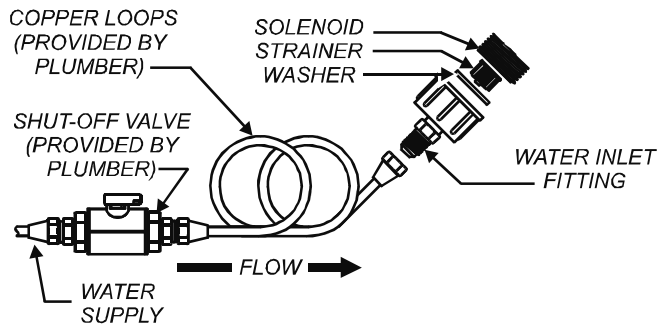

Fig. 2 Water Supply Installation

In some areas, local codes require a backflow preventer (check valve) to be installed on the inlet water line. If a backflow preventer is used, you must install a *water hammer arrester* in the incoming line, between the backflow preventer and the brewer inlet, as far away from the brewer as space will allow. This will relieve the excessive back pressures that can cause faucet leaks and solenoid malfunctions.



CAUTION: ELECTRICAL DAMAGE

DO NOT plug in or energize this appliance until all Installation Instructions are read and followed. Damage to the Brewer will occur if these instructions are not followed.

NOTE: Water supply inlet line must meet certain minimum criteria to insure successful operation of the brewer. Bloomfield recommends 1/4" copper tubing for installation of less than 12 feet and 3/8" for more than 12 feet from a 1/2" water supply line.

NOTE: This equipment must be installed to comply with applicable federal, state and local plumbing codes and ordinances.

IMPORTANT:

Water pressure must be between 20 p.s.i and 90 p.s.i. flowing pressure. If water pressure exceeds this value, or if water pressure varies greatly, a pressure regulator must be installed in the water supply line.

INSTALLATION (continued)



WARNING: **SHOCK HAZARD**

Brewer must be properly grounded to prevent possible shock hazard. DO NOT assume a plumbing line will provide such a ground. Electrical shock will cause death or serious injury.

IMPORTANT:

Supply power must match nameplate for voltage and phase. Connecting to the wrong voltage will damage the brewer or result in decreased performance. Such damage is not covered by warranty.

IMPORTANT:

Do not connect brewer to electrical power until you are ready to fill the tank. See instructions on page 7.

IMPORTANT:

The ground prong of the plug is part of a system designed to protect you from electrical shock in the event of internal damage. Never cut off the ground prong nor twist a blade to fit an existing receptacle. Contact a licensed electrician to install the proper circuit and receptacle.

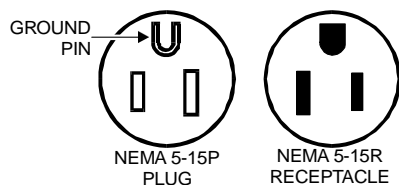

Fig. 3 Power Supply Plug

ELECTRICIAN'S INSTALLATION INSTRUCTIONS

REFER TO ELECTRICAL SPECIFICATIONS - Page 1
Check the nameplate to determine correct electrical service required for the Brewer to be installed.

IMPORTANT: Before connecting to electricity, make sure brewer is connected to the water supply.

This brewer is equipped with a cord and plug. It will require a 115 - 125 volt 20 amp circuit (50/60 Hz, 2 wire plus ground, with NEMA 5-15R or 5-20R Receptacle).

See Figure 3 below left.

OPERATION

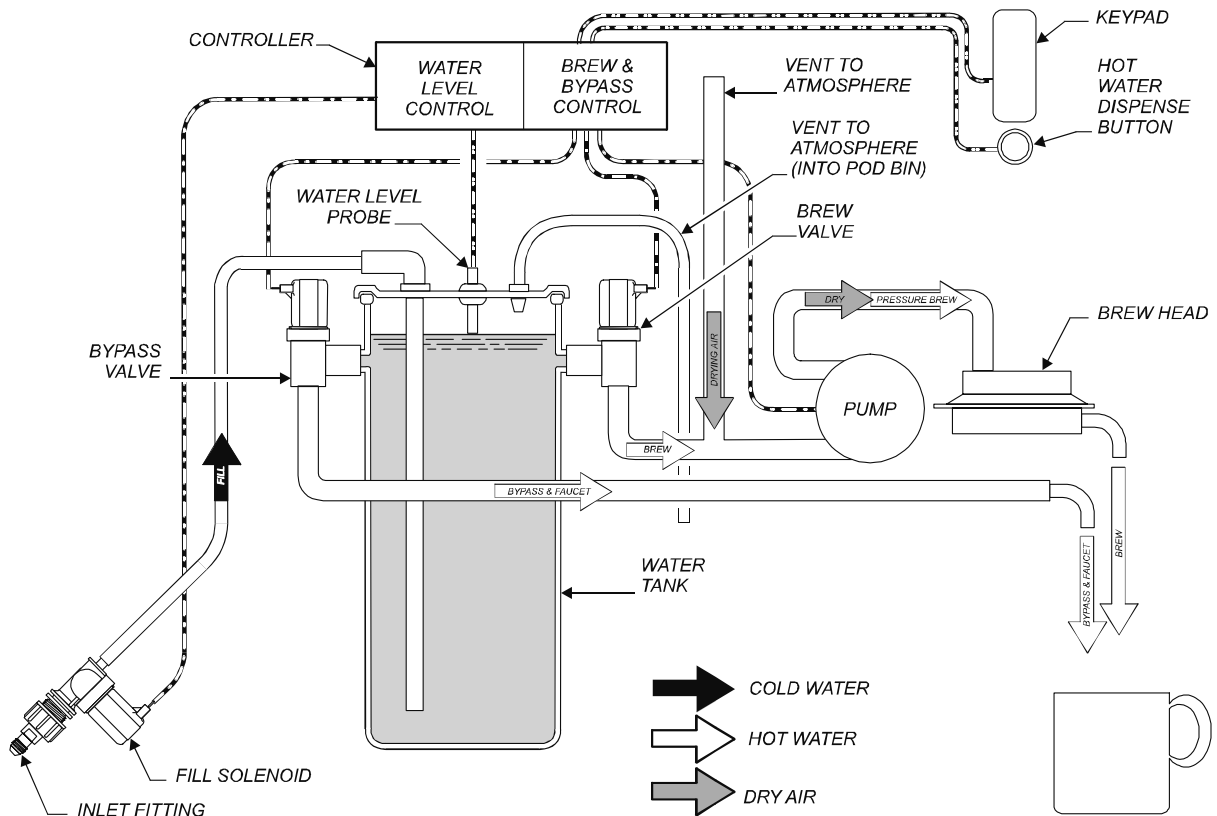

Fig. 4 Water Flow Diagram

A. START-UP

For initial start-up, or if the brewer has not been used for an extended period of time:

- ◆ Be sure the water supply is properly connected and the water supply valve is turned *ON*.
- ◆ Be sure that TANK HEATER SWITCH is *OFF* before connecting brewer to electric power.
- ◆ Be sure the WATER TANK IS FILLED.

IMPORTANT: Fill the water tank before energizing this brewer.

1. Connect brewer to electric power. Brewer will begin filling. When solenoid closes, tank is full.
2. Place an empty container on the cup grid. Press the HOT WATER DISPENSE BUTTON and dispense one cup of water. Tank should refill. Discard water.
3. Press TANK HEATER SWITCH to *ON*.
4. When READY light glows, brewer is ready to use.

IMPORTANT:
TANK MUST BE FULL OF WATER BEFORE CONNECTING BREWER TO ELECTRIC POWER.

Heating elements will be damaged if allowed to operate without being fully submerged in water. Damage caused by operating the brewer without water in the tank is **NOT COVERED BY WARRANTY**.

See page 8 for setting delivered water volumes for VOLUME SELECTION KEYS.

OPERATION (continued)

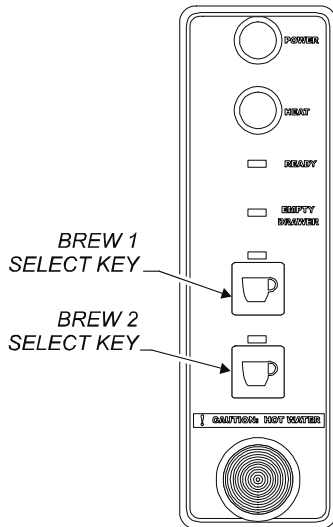

Fig. 5 Program Brew Select Keys

NORMAL BREW	NORMAL BREW WITH DILUTION
PULSE BREW	PULSE BREW WITH DILUTION

Table 1.
FOUR BREW OPTIONS

B. PROGRAM BREW VOLUMES

- ◆ Each BREW SELECT KEY is individually programmable.
- ◆ Keys may be programmed for pulse brewing to optimize contact times and extraction rates.
- ◆ Up to 10 pulses may be programmed. Each pulse delay is fixed at 4 seconds.
- ◆ Dilution for each BREW SELECT KEY is individually programmable (usually used for brewing tea).

1. Load a fresh pod in the pod holder and lock the pod in place. Place an empty cup on the cup grid. See page 9.
2. Press and hold both BREW SELECT KEYS for 5 seconds until a beep sounds.
3. Program BREW 1 SELECT key

IMPORTANT: Allow for an additional 2 oz to be pushed through during the drying cycle at the end of the brew.

- a. Press and release the key to start water flow.
- b. Press and release the key to stop water flow when desired volume is reached. Press and hold the key for 3 seconds (until a beep sounds) to enter the setting into memory.

- OR -

For PULSE BREW:

- a. Press and release the key to start the water flow.
- b. Press and release the key again to stop the flow after the time desired for the first pulse.
- c. Press the key again to resume water flow.
- d. Repeat until desired total delivered volume is reached.

NOTE: Water flow can be stopped and restarted up to 10 times per brew. The delay between pulses is fixed at 4 seconds.

- AND -

For DILUTION:

- a. Press and release the BREW 2 SELECT KEY to start hot water flow at any time during the programming sequence.
 - b. Press and release the key again to stop the flow when the desired amount of hot water is reached.
4. Press and hold the BREW KEY for 3 seconds (until the beep sounds) enters these settings into memory.

NOTE: Pod must be refreshed before operation can resume.
 5. Repeat steps 1 through 4 for BREW 2 SELECT KEY.

NOTE: In this mode, BREW 1 SELECT KEY is used to program dilution.
 6. Run a normal brew to verify settings.

NOTE: Pump is factory programmed to run for 15 seconds at the end of the brew cycle. Pulling air from the vent tube will dry the used pod.

OPERATION - BREWING COFFEE

1. Unlock the pod holder by pulling the LOCKING LEVER fully forward.
2. Pull the BREW TRAY fully forward, then lower tray.

NOTE: Normally, the brewer will automatically discard the last pod. If the brewer has not been used for some time, the used pod may need to be removed by hand. Deposit the used pod in the pod bin.

3. Center a fresh pod on the grid of the LOWER POD HOLDER.

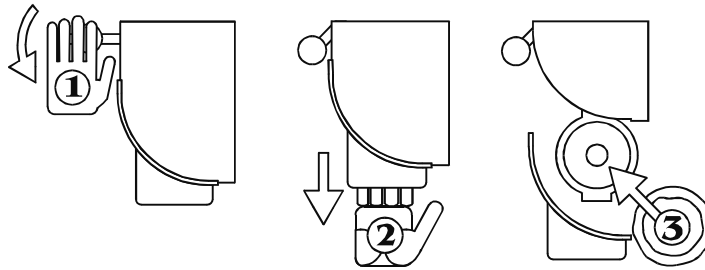

4. Raise the BREW TRAY and slide fully to the rear.
5. Gently pull the LOCKING LEVER **DOWN**, then push it fully to the rear to lock the pod holder.
6. Place an *EMPTY* cup on the CUP GRID, under the BREW NOZZLE.
7. When the READY light glows, press the appropriate BREW KEY. Fresh coffee (or tea) will begin to fill the cup. Three beeps will sound. When all dripping stops, beverage is ready to serve.

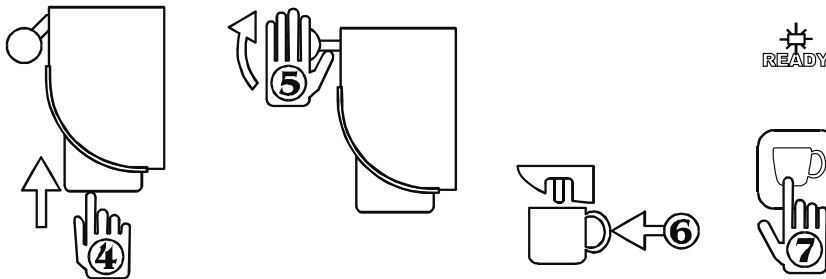

SUGGESTION: If the brewer is likely to remain unused for some time, discard the used pod:

1. Unlatch the pod holder by pulling the LOCKING LEVER fully forward.
2. Pull the BREW TRAY fully forward. This will automatically eject the used pod.
3. Slide the tray fully to the rear. In order to prevent an unintended brew, do not lock the pod holder.



CAUTION: BURN HAZARD

Exposed surfaces of the brewer may be HOT to the touch, and can cause serious burns.



CAUTION: BURN HAZARD

To avoid splashing or overflowing hot liquids, ALWAYS place an EMPTY cup on the cup grid before starting the brew cycle. Failure to comply can cause serious burns.



CAUTION: BURN HAZARD

After a brew cycle, pod holder and used pod may be HOT. Remove and dispose of used pods with care. Failure to comply can cause serious burns.

NOTE: Press the same BREW SELECT KEY at any time during the brew to CANCEL.

FOR HOT WATER:
Place an empty cup on the CUP GRID under the FAUCET NOZZLE. Press the HOT WATER DISPENSE button. Release the button to stop the flow.

NOTE:
Hot water dispense is disabled during brew cycle.

If the EMPTY DRAW light is lit, the used pod bin is full. Remove the drip tray assembly, then withdraw and empty the POD DRAWER.

CLEANING INSTRUCTIONS



CAUTION: BURN HAZARD

Brewing and serving temperatures of coffee and tea are extremely hot. Hot beverage will cause serious skin burns.

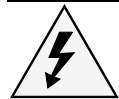

CAUTION: SHOCK HAZARD

DO NOT submerge or immerse brewer in water. DO NOT pour, spill or splash water onto, into or over any internal component.

IMPORTANT:

DO NOT use steel wool, sharp objects, or caustic, abrasive or chlorinated cleansers to clean the brewer.

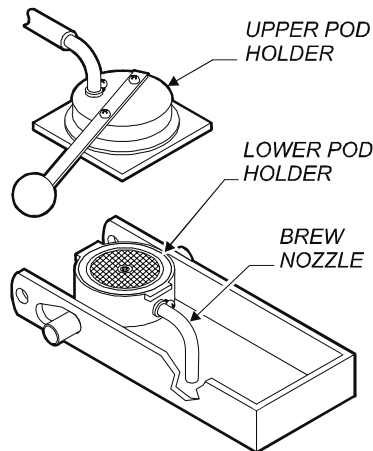

Fig. 6 Cleaning

PROCEDURE: Clean Coffee Brewer

PRECAUTIONS: Disconnect brewer from electric power.
Allow brewer to cool.

FREQUENCY: Daily

TOOLS: Mild Detergent, Clean Soft Cloth or Sponge
Bristle Brush, Bottle Brush

1. Disconnect brewer from electric power. Allow brewer to cool before cleaning.
2. Remove any cup, then remove drip tray and cup grid.
3. Remove and empty pod drawer.
4. Unlatch pod holder and slide brew tray fully forward. Remove and discard any used pod.
5. Wipe both top and bottom pod holders, brew nozzle and the area around the pod holder with a soft clean cloth or sponge moistened with warm water and a mild detergent. Rinse by wiping with a clean cloth moistened with clean water.
6. Wash the pod drawer, drip tray and cup grid in a sink using warm water and a mild detergent. Rinse with clean water and allow to air dry.
7. Wipe the exterior of the brewer with a soft clean cloth or sponge moistened with clean water.
8. Reinstall the pod drawer, then reinstall the drip tray and cup grid.
9. Slide the tray fully to the rear. In order to prevent an unintended brew, do not lock the pod holder.

Procedure is complete

SANITIZING INSTRUCTIONS

PROCEDURE: Sanitize Coffee Brewer

PRECAUTIONS: None

FREQUENCY: Weekly

TOOLS: Pod Sanitizer Packet
Empty Container



CAUTION: BURN HAZARD

Brewing and serving temperatures of coffee and tea are extremely hot. Hot beverage will cause serious skin burns.

1. Unlock the pod holder by pulling the LOCKING LEVER fully forward.
2. Pull the BREW TRAY fully forward.
3. Fold back corners of a fresh POD SANITIZER PACKET as required to fit pod holder. Center packet on the grid of the LOWER POD HOLDER.
4. Slide the BREW TRAY fully to the rear.
5. Gently pull the LOCKING LEVER **DOWN**, then push it fully to the rear to lock the pod holder.
6. Place an *EMPTY* container under the BREW NOZZLE.
7. Press a BREW KEY. When water begins to fill the container, press BREW KEY again to stop flow.
8. Allow unit to sit undisturbed for 1 minute.
9. After 1 minute, pull LOCKING LEVER forward, then push it fully to the rear to reset brew function (DO NOT eject sanitizing pod). Press BREW KEY to restart flow cycle.
10. When all flow and dripping stops, unlock the pod holder by pulling the LOCKING LEVER fully forward.
11. Pull the BREW TRAY fully forward to eject the sanitizer packet, then slide it fully to the rear. Gently pull the LOCKING LEVER **DOWN**, then push it fully to the rear to lock the pod holder.
12. Press a BREW KEY to rinse.
13. Open the brew tray and examine the components for cleanliness. If oils and other brewing residue remain, repeat steps 1 through 12 as required.
14. Remove the drip tray assembly and empty the pod drawer. Reinstall the pod drawer and drip tray assembly.

Procedure is complete

Sanitizing is necessary to remove those oils and other brewing residues that build up on internal surfaces, and are not accessible during daily cleaning.

TROUBLESHOOTING SUGGESTIONS

SYMPTOM	POSSIBLE CAUSE	SUGGESTED REMEDY
Water won't heat	Tank heater switch OFF	Press switch to ON
	Brewer unplugged or circuit breaker tripped	Check power supply cord Check / reset circuit breaker
	Temperature setpoint too low	Set for desired temperature
	Hi-Limit safety switch tripped	Allow to cool hi-limit will self-reset
	Damaged internal component or wiring	Examine wiring & connectors, controller, water level probe and heating element Repair/replace as needed
Coffee level too high or low	Brew select keys not properly programmed	Program brew select keys See page 8
Tea brew is too strong or weak	Brew select keys not properly programmed for dilution	Program brew select keys See page 8
No brew plus no flow from hot water faucet	Water supply OFF	Turn water supply ON
	Solenoid inlet strainer plugged	Clean strainer
	Water filter (if used) plugged	Replace filter element
	Damaged internal component or wiring	Check wiring & connectors, inlet solenoid, controller and water level probe
No brew (faucet flows OK)	Brew nozzle plugged	Disassemble and clean lower pod holder.
	Damaged internal component or wiring	Check wiring & connectors, pump and brew valve
No flow from hot water faucet (brew OK)	Damaged internal component or wiring	Check wiring & connectors, faucet valve and dispense switch
Pod not dried at end of brew	Vent hose kinked	Check/repair vent hose
Poor coffee quality	Keep brewer and cups clean. Install optional taste and odor filter, and replace cartridges regularly. Use a fresh quality pod with a consistent roast for each brew.	

SERVICING INSTRUCTIONS

ACCESS PANELS

TOP PANEL:

Remove top panel to access hot water tank, thermostat, heating elements, brew pump and tubing, brew solenoid, hot water dispenser solenoid and piping, pod holders and brew tray,

Top panel is held by screws around the edge.

Remove pod drawer to access bottom of brew tray.

SOLENOID DOOR:

Remove solenoid door to access solenoid plumbing connections.

Solenoid door is held by two screws and a retaining lip.

POD DRAWER / BREW TRAY:

Remove pod drawer and slide brew tray out fully to access pod holders and eject mechanism.

Remove drip tray assembly to access pod drawer. Pod drawer slides straight out.



CAUTION: SHOCK HAZARD

Opening access panels on this brew may expose uninsulated electrical components. Disconnect brewer from electrical power before removing any panel.

Trouble shooting instructions, component views and parts lists in this manual are included for general reference, and are intended for use by qualified service personnel only.

SERVICING INSTRUCTIONS (continued)

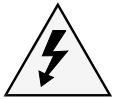

CAUTION: SHOCK HAZARD

These procedures involve exposed electrical circuits. These procedures are to be performed by qualified technical personnel only.

NOTE:

Optimum brewing temperature range is 195°F to 205°F (90°C to 96°C).

IMPORTANT:

A mechanical thermostat will maintain temperature within $\pm 5^\circ\text{F}$. To prevent boiling water in the brewer, thermostat should be adjusted to a maximum temperature equal to the local boiling temperature minus 5°F .

TEMPERATURE ADJUSTMENT

Disconnect brewer from electric power.

Pull vent tube out of tank lid and insert a thermometer of known accuracy in hole. Reconnect brewer to electrical power. Place empty cup on the cup grid. Energize brewer and allow unit to heat. When READY light glows, read the temperature displayed on thermometer.

Adjust thermostat by turning shaft; clockwise increases temperature. $1/8$ turn = approximately 10°F .

Refer to Table 1 below for proper brewing temperature based on altitude.

Upon completion, remove thermometer and reinstall the vent.

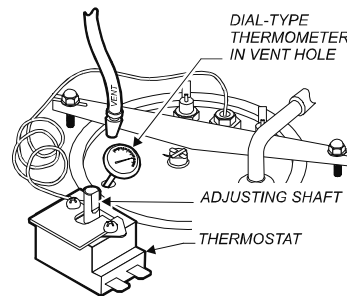

Fig. 7 Checking and Adjusting Brew Temperature

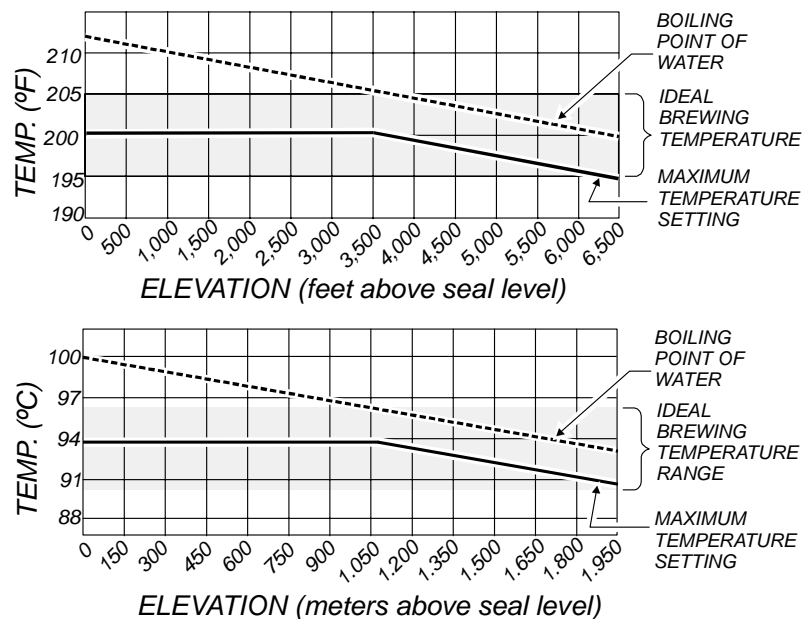

Table II Boiling Temperature by Altitude

SERVICING INSTRUCTIONS (continued)

REMOVE TANK LID ASSEMBLY

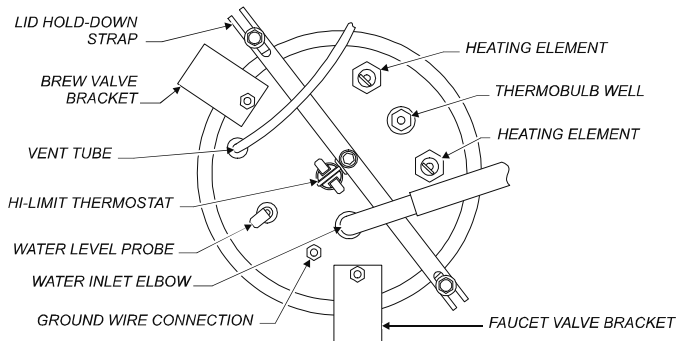

Fig. 8 Tank Lid Configuration

Disconnect brewer from electric power. Turn *OFF* water supply. Remove top panel. Pull vent tube, inlet elbow and water level probe out of tank lid. Remove hi-limit thermostat from bracket.

Disassemble brew valve bracket and faucet valve bracket from tank lid. Loosen and free jam nut from pass-thru fitting securing thermobulb. Withdraw bulb from well.

Disconnect all wiring from heating element. Remove tank ground wire.

Loosen nuts and center screw on tank hold-down strap. Remove hold-down strap by sliding short slotted end off of locking stud and lifting it off. Remove cover assembly by lifting it straight up.

Reassemble in reverse order. Be sure tank lid gasket is properly positioned before tightening hold-down strap.

REPLACE THERMOSTAT (COTHERM)

Disconnect brewer from electric power. Turn *OFF* water supply. Remove top panel.

Disconnect all wiring from thermostat only. Loosen and free jam nut from pass-thru fitting securing thermobulb. Withdraw bulb from well. Remove two screws holding thermostat to bracket.

Lift out thermostat, sensing bulb and thermostat gasket.

Reassemble in reverse order. **BE SURE** the bulb well is fully seated in the tank fitting, and that the temperature sensing bulb is inserted to the very bottom of the bulb well.

REPLACE HEATING ELEMENT

Remove tank lid assembly per above.

Remove two hex nuts holding element to cover. Pull element from mounting holes.

Reassemble in reverse order.

IMPORTANT:

Before setting assembly into tank, make sure tank lid gasket is properly seated on flange of lid. **DO NOT OVER-TIGHTEN.**

IMPORTANT:

When mounting thermostat, be sure to insert sensing bulb to the bottom of the bulb well. Tighten capillary lock nut only enough to ensure no water leakage. Excessive tightening is not necessary.

IMPORTANT:

When replacing heating element, also replace seal gaskets.

SERVICING INSTRUCTIONS (continued)

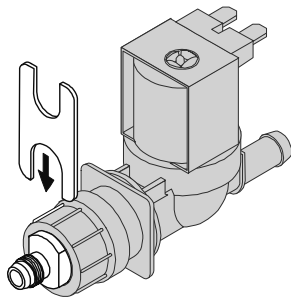

Fig. 9 Wrench #86660

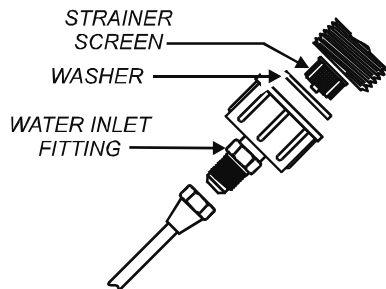

Fig. 10 Clean Strainer Screen

REPLACE SOLENOID

Symptom: Brewer will not flow water; or, brewer drips continuously from pod holder or brew nozzle.

NOTE: Wrench p/n 86660 is designed to allow easy removal of flare nuts from the water inlet fitting

IMPORTANT: Shut-off water to brewer and disconnect brewer from electric power before removing hoses or wiring.

Remove water supply flare fitting:

- Slide the 5/8" end of the wrench over the flats on the inlet fitting of the valve.
- Hold the wrench to prevent the inlet fitting from turning while installing or removing the inlet water supply flare nut.

Remove fill tubing:

Disconnect wiring.

Remove two screws holding solenoid to access door.

Reassemble in reverse order.

CLEAN SOLENOID SCREEN

Symptom: Automatic brewer will not flow water.

Disconnect brewer from electric power. Turn *OFF* and disconnect water supply from brewer inlet fitting.

Unscrew water inlet fitting from solenoid.

Using needle-nose pliers, withdraw strainer screen from solenoid. Clean screen under faucet. A stiff bristle brush may be used if necessary.

Reinsert screen in solenoid. Be careful to maintain correct orientation. (The *OPEN END* of the screen goes in *FIRST*.)

Reassemble in reverse order.

SERVICING INSTRUCTIONS (continued)

IMPORTANT: TO BE PERFORMED BY A QUALIFIED TECHNICAL ONLY

CLEAN UPPER POD HOLDER

Remove drip tray assembly and pod drawer. Slide brew tray fully forward.

NOTE: Upper pod holder can be cleaned in place. It is not normally necessary to remove the pod holder from the carriage for cleaning.

Remove retaining screw from spray disk. Remove disk from pod holder.

Remove upper ring plate and ring gasket from pod holder body. If necessary, remove retaining screw and elbow fitting. Be sure elbow fitting o-ring and ring plate o-ring are properly reinstalled after cleaning.

Clean all components using mild detergent and clean water. Rinse with clean water.

Reassemble In reverse order. Be sure ring gasket is fully seated before locking pod holder halves together.

CLEAN LOWER POD HOLDER

Remove drip tray assembly. Slide brew tray fully forward.

NOTE: Lower pod holder can be cleaned in place. It is not normally necessary to remove the pod holder from the carriage for cleaning.

Remove retaining screw from spray disk. Remove disk from pod holder.

Remove lower ring plate and o-ring from pod holder body. If necessary, remove retaining screw and elbow fitting. Be sure elbow o-ring is properly reinstalled after cleaning.

Clean all components using mild detergent and clean water. Rinse with clean water.

Reassemble In reverse order.



**CAUTION:
SHOCK HAZARD**

DO NOT pour, spill or splash water onto, into or over any internal component.

IMPORTANT:

DO NOT use steel wool, sharp objects, or caustic, abrasive or chlorinated cleansers to clean these components.

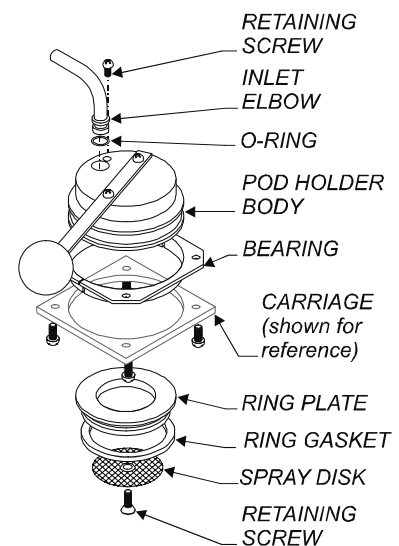

Fig. 11 Upper Pod Holder

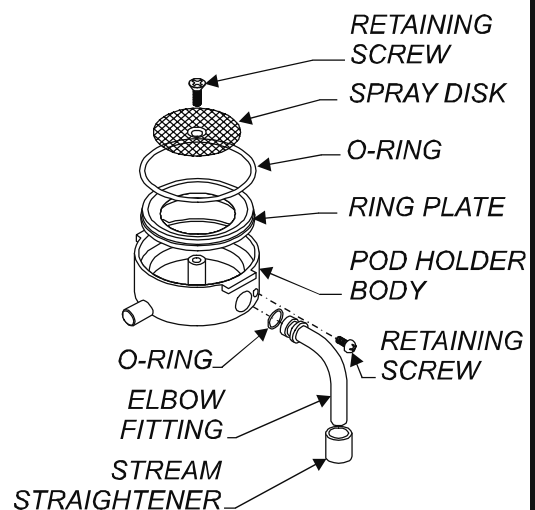

Fig. 12 Lower Pod Holder

SERVICING INSTRUCTIONS (continued)

IMPORTANT:

The two keypad ribbon cables connectors are not polarized and can easily be installed in the wrong position. Be sure to mark the ribbon cable connectors for orientation.

REPLACE CONTROLLER

Disconnect brewer from electric power. Remove top panel

Note location of wire connections. Be sure to mark the two keypad ribbon cables as to orientation. Disconnect wiring from controller.

Remove four nuts holding controller to cabinet.

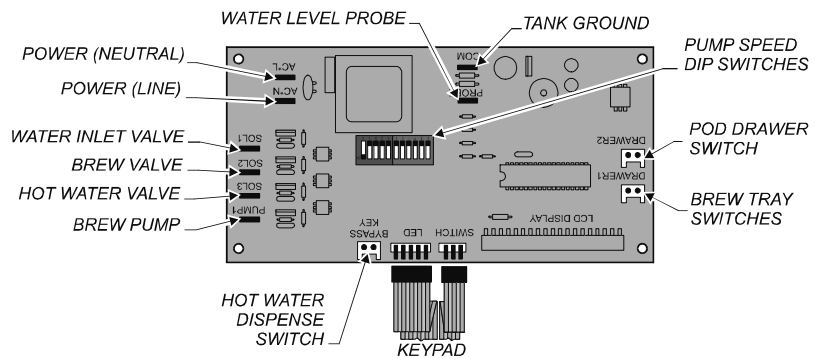

Fig. 11 Controller Wiring Configuration

Reassemble in reverse order. Be sure motor speed dip switches are set with RED 5 ON, all others OFF.

SERVICING INSTRUCTIONS (continued)

PROCEDURE: Delime the Water Tank

PRECAUTIONS: Disconnect brewer from electric power.
Allow brewer to cool.

FREQUENCY: As required (Brewer slow to heat)

TOOLS: Deliming Solution
Protective Gloves, Goggles & Apron
Mild Detergent, Clean Soft Cloth or Sponge
Bristle Brush, Bottle Brush
Large Sink (or other appropriate work area)

1. Disconnect brewer from electric power. Turn off the water shut-off valve and disconnect the water supply line from the brewer inlet fitting.
2. Remove the tank lid assembly as described on page 15.
3. Remove the water tank from the brewer body by lifting straight up. Empty all water from the tank. Set the tank back into the brewer.
4. Mix 2 quarts of deliming solution according to the manufacturer's directions. Carefully pour the deliming solution into the water tank. Lower the lid assembly back onto the tank. Allow to sit for 30 minutes, or as directed by the manufacturer.
5. At end of soaking period, remove lid assembly from tank. Thoroughly rinse internal components of lid assembly with clear water. Using a stiff bristle brush, scrub the heating element (and faucet water coil on automatic brewers) to remove lime and calcium build-up. Rinse with clean water. Store lid assembly in a safe location .
6. Remove the tank from the brewer and empty. Using a stiff bristle brush, scrub the interior of the water tank to remove lime and calcium build-up. Rinse with clean water.
7. Set the tank back into the brewer. Reassemble the tank lid to the water tank. Make sure the gasket is properly in place, then reinstall the hold-down strap.
8. Reinstall wiring to heating element and thermostat. Reinstall the hi-limit thermostat (if removed). For automatic brewers, reassemble piping for the faucet. Verify that all internal components are dry, then reinstall the top panel.
10. Reconnect brewer to electrical supply and, for automatic brewers, reconnect water supply.
11. Run at least ten full brew cycles without pods, and discard all water generated.
12. Brewer is ready to use.



CAUTION: CHEMICAL BURN HAZARD

Deliming chemicals may be caustic. Wear appropriate protective gloves and goggles during this procedure. Never siphon deliming chemicals or solutions by mouth.

This operation should only be performed by qualified and experienced service personnel.

IMPORTANT: DO NOT spill, splash or pour water or deliming solution into or over any internal component other than the inside of the water tank.

IMPORTANT: DO NOT allow any internal components to come into contact with the deliming solution. Take care to keep all internal components dry.

NOTE: Repeat steps 4 thru 5 as required to remove all scale and lime build-up.

NOTE: Normally, silicone hoses do not need to be delimed. Should deliming hoses become necessary, Bloomfield recommends replacing the hoses.

EXPLODED VIEW & PARTS LIST

CABINET COMPONENTS

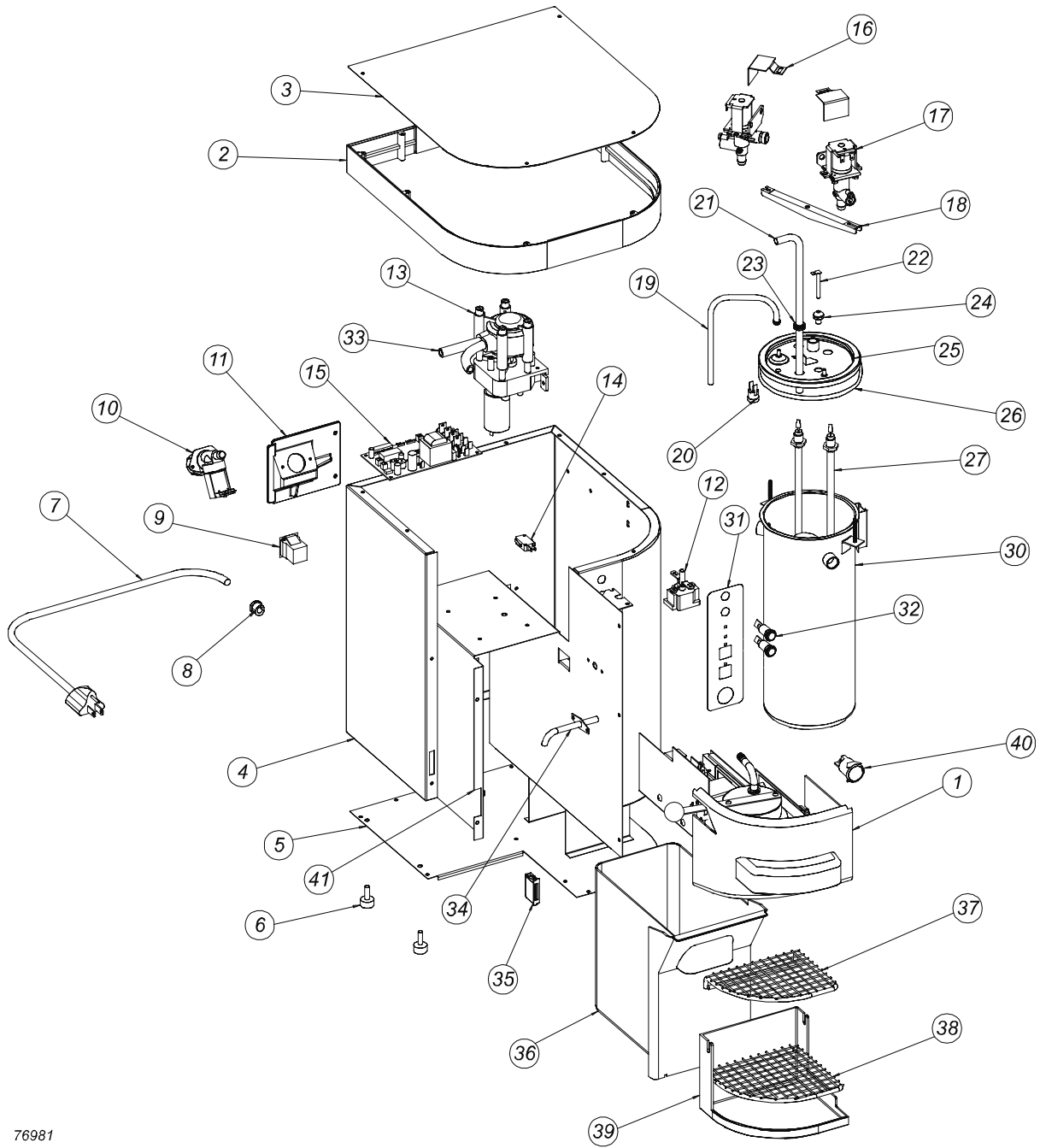

76981

EXPLODED VIEW & PARTS LIST (continued)

ITEM	PART NO.	DESCRIPTION	QTY	ITEM	PART NO.	DESCRIPTION	QTY
1	(page 22)	BREW DRAWER ASSY	1	25	86968	TANK COVER	1
2	87136	UPPER HOUSING, LEFT	1	26	8043-12	GASKET, TANK COVER	1
	87175	UPPER HOUSING, CENTER	2	27	8043-14	HEATING ELEMENT, 1500W 120V	1
	87137	UPPER HOUSING, RIGHT	1	28	8043-30	SEAL, HEATING ELEMENT	2
3	86976	COVER, TOP	1	29	8043-28	NUT, 1/2-20 BRASS ELEMENT	2
4	86975	LOWER HOUSING	1	30	86984	WATER TANK ASSY	1
5	86982	BASE ASSY	1	31	86962	OVERLAY KEYPAD	1
6	81732	LEG, LEVELING	4	32	8718-31	LIGHT PILOT GREEN 120V	2
7		CORD & CAP, NEMA 5-15P	1	33	87193	TUBING, STA-PURE	1
8	86618	STRAIN RELIEF	1	34	86959	BYPASS SPOUT ASSY	1
9	84382	SWITCH, ON/OFF	1	35	87178	LATCH MAGNETIC	1
10	84427	SOLENOID SINGLE 1.0 GPM	1	36	86952	POD DRAWER	1
11	85089	SOLENOID ACCESS DOOR	1	37	86958	CUP GRID	1
12	86280	THERMOSTAT (COTHERM)	1	38	86895	GRID, DRIP TRAY	1
13	86963	PUMP, HOT WATER 12VDC	1	39	86895	DRIP TRAY	1
14	50198	SWITCH, POD BIN	1	40	86964	PUSH SWITCH, 120V HOT WATER	1
15	87196	CONTROL BOARD	1	41	86967	HOUSING, HOPPER	1
16	86969	BRACKET, VALVE MOUNTING	2	HARDWARE NOT SHOWN			
17	83388	VALVE, WATER OUTLET	2	42	3-100	SCREW 8-32x1/4 PH SS	2
18	8043-5	STRAP, TANK HOLD-DOWN	1	43	87190	SCREW #6 PH BLACK	4
19	8706-20	VENT TUBE LONG	1	44	86979	SCREW 8-32x3/8 HI-LO PH SS	14
20	8043-83	HI-LIMIT THERMOSTAT	1	45	83457	NUT 8-32 HEX KEPS SS	7
21	87172	TUBE, FILL	1	46			
22	83521	PROBE, WATER LEVEL	1	47			
23	82390	GROMMET, 3/8	1	48			
24	83532	SLEEVE, PROBE	1	49			

EXPLODED VIEW & PARTS LIST

BREW TRAY COMPONENTS

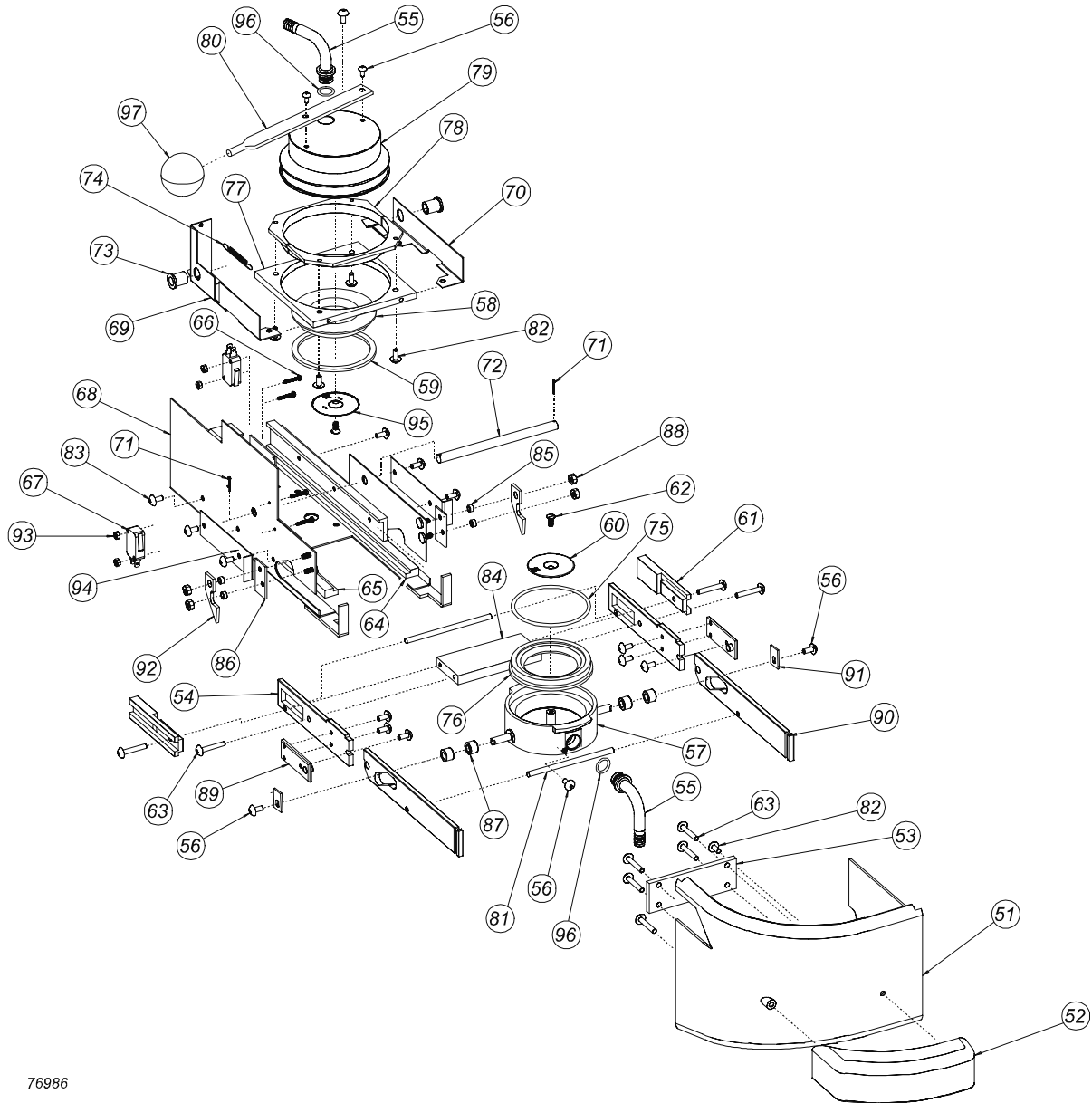

76986

EXPLODED VIEW & PARTS LIST (continued)

ITEM	PART NO.	DESCRIPTION	QTY	ITEM	PART NO.	DESCRIPTION	QTY
51	86946	DRAWER FRONT	1	76	86846	RING PLATE LOWER	1
52	86947	DRAWER PULL	1	77	86843	LIFT PLATE	1
53	89861	FRONT PLATE	1	78	86966	BEARING POD CARRIER	2
54	86951	DRAWER ARM	2	79	86842	UPPER POD CARRIER	1
55	85621	ELBOW FITTING	2	80	86845	LEVER ARM	1
56	55487	SCREW 8-32x5/16 TR SS	12	81	86887	ROD SPACER	2
57	86957	LOWER POD CARRIER ASSY	1	82	86979	SCREW 8x3/8 BLK OX	5
58	86847	PLATE RING UPPER	1	83	57725	SCREW 8Bx1/4 PH	6
59	86949	SEAL RING	1	84	87074	SPACER BLOCK	1
60	86956	SPRAY DISK LOWER	1	85	85888	SPACER NYLON	4
61	86844	ARM GUIDE	2	86	87182	SPACER KEY	2
62	86972	SCREW 8-32x1/4 FH SS	2	87	87091	NEEDLE BEARING	4
63	86978	SCREW 8x1 PH HI-LO	9	88	83457	NUT KEPS 8-32 SS	4
64	86848	DRAWER GLIDE RIGHT	1	89	87086	HINGE PLATE	2
65	86852	DRAWER GLIDE LEFT	1	90	87087	DRAWER ARM FRONT	2
66		SCREW 4-40x5/8	4	91	87090	FLAG	2
67	50198	SWITCH	2	92	87089	KEY	2
68	86849	DRAWER CARRIER	1	93	80146	NUT HEX 4-4- SS	4
69	89858	SWING ARM LEFT	1	94	87194	STOP POD ROTATION	2
70	86851	SWING ARM RIGHT	1	95	87186	SPRAY DISK UPPER	1
71	86980	COTTER PIN .06Dx.5 SS	2	96	87197	O-RING 2-110	2
72	86977	PIVOT ROD	1	97	87211	KNOB, LEVER	1
73	86974	BEARING THRUST	2	98			
74		SPRING	1	99			
75	86970	O-RING 2-039	1	100			

EXPLODED VIEW & PARTS LIST (continued)

SERVICE PARTS KITS

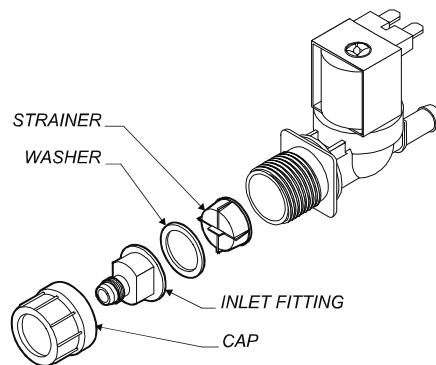

- | | |
|-------|---|
| 84427 | VALVE ASSEMBLY, COMPLETE |
| 85218 | INLET FITTING KIT (Includes cap, fitting, gasket & strainer) |
| 85219 | INLET STRAINER |

WIRING DIAGRAM

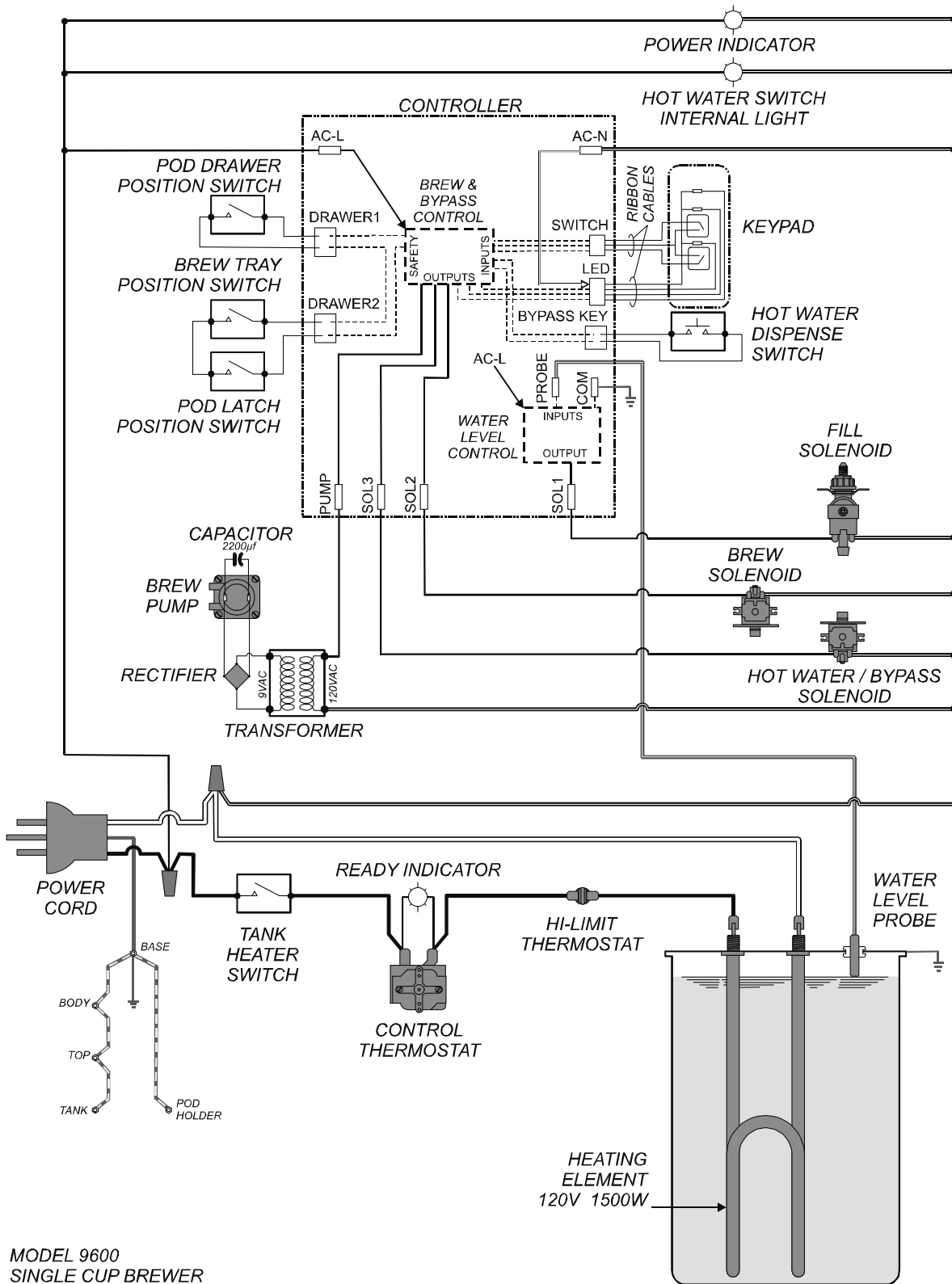

MODEL 9600
SINGLE CUP BREWER

CFESA

Commercial Food Equipment Service Association

Bloomfield Industries proudly supports CFESA
Commercial Food Equipment Service Association

SERVICE TRAINING - QUALITY SERVICE



CUSTOMER SATISFACTION



BLOOMFIELD

Bloomfield Industries, Inc.
Division of Carrier Commercial Refrigeration

In US and Canada

Telephone: 775-689-5700

Fax: 888-492-2783

Fax: 800-356-5142 (*for orders only*)

website: www.wellsbloomfield.com

PRINTED IN CHINA