

# BUNN®

***AFPO-2***  
***AFPO-2 SL***  
***AFPO-3***  
***AFPO-3 SL***

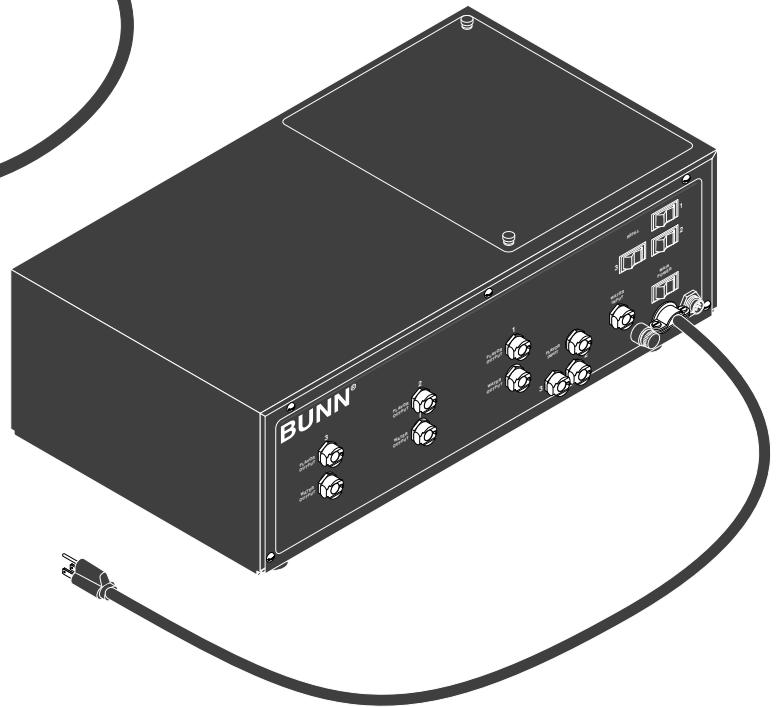
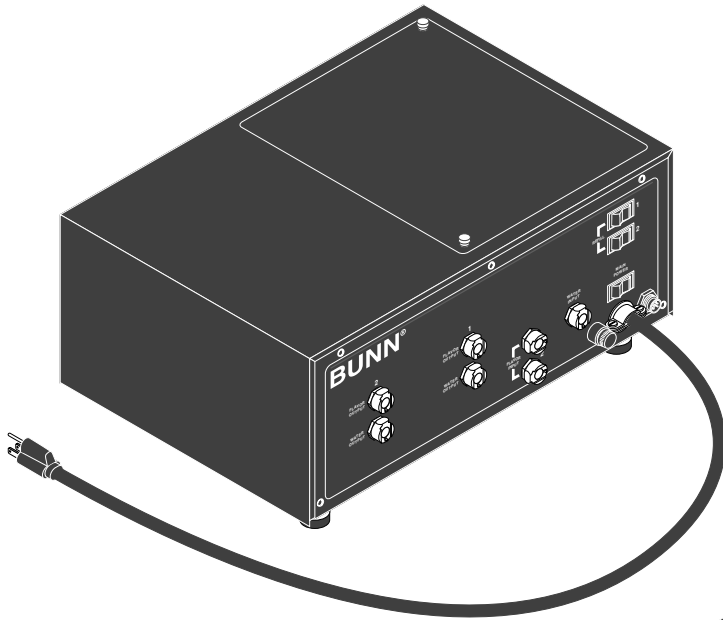

## ILLUSTRATED PARTS CATALOG

Designs, materials, weights, specifications, and dimensions for equipment or replacement parts are subject to change without notice.

**BUNN-O-MATIC CORPORATION**

POST OFFICE BOX 3227

SPRINGFIELD, ILLINOIS 62708-3227

PHONE: (217) 529-6601 FAX: (217) 529-6644



## **BUNN-O-MATIC COMMERCIAL PRODUCT WARRANTY**

Bunn-O-Matic Corp. ("BUNN") warrants equipment manufactured by it as follows:

- 1) Airpots, thermal carafes, decanters, GPR servers, iced tea/coffee dispensers, MCP/MCA pod brewers thermal servers and Thermofresh servers (mechanical and digital)- 1 year parts and 1 year labor.
- 2) All other equipment - 2 years parts and 1 year labor plus added warranties as specified below:
  - a) Electronic circuit and/or control boards - parts and labor for 3 years.
  - b) Compressors on refrigeration equipment - 5 years parts and 1 year labor.
  - c) Grinding burrs on coffee grinding equipment to grind coffee to meet original factory screen sieve analysis - parts and labor for 4 years or 40,000 pounds of coffee, whichever comes first.

These warranty periods run from the date of installation BUNN warrants that the equipment manufactured by it will be commercially free of defects in material and workmanship existing at the time of manufacture and appearing within the applicable warranty period. This warranty does not apply to any equipment, component or part that was not manufactured by BUNN or that, in BUNN's judgment, has been affected by misuse, neglect, alteration, improper installation or operation, improper maintenance or repair, non periodic cleaning and descaling, equipment failures related to poor water quality, damage or casualty. In addition, the warranty does not apply to replacement of items subject to normal use including but not limited to user replaceable parts such as seals and gaskets. This warranty is conditioned on the Buyer 1) giving BUNN prompt notice of any claim to be made under this warranty by telephone at (217) 529-6601 or by writing to Post Office Box 3227, Springfield, Illinois 62708-3227; 2) if requested by BUNN, shipping the defective equipment prepaid to an authorized BUNN service location; and 3) receiving prior authorization from BUNN that the defective equipment is under warranty.

**THE FOREGOING WARRANTY IS EXCLUSIVE AND IS IN LIEU OF ANY OTHER WARRANTY, WRITTEN OR ORAL, EXPRESS OR IMPLIED, INCLUDING, BUT NOT LIMITED TO, ANY IMPLIED WARRANTY OF EITHER MERCHANTABILITY OR FITNESS FOR A PARTICULAR PURPOSE.** The agents, dealers or employees of BUNN are not authorized to make modifications to this warranty or to make additional warranties that are binding on BUNN. Accordingly, statements by such individuals, whether oral or written, do not constitute warranties and should not be relied upon.

If BUNN determines in its sole discretion that the equipment does not conform to the warranty, BUNN, at its exclusive option while the equipment is under warranty, shall either 1) provide at no charge replacement parts and/or labor (during the applicable parts and labor warranty periods specified above) to repair the defective components, provided that this repair is done by a BUNN Authorized Service Representative; or 2) shall replace the equipment or refund the purchase price for the equipment.

**THE BUYER'S REMEDY AGAINST BUNN FOR THE BREACH OF ANY OBLIGATION ARISING OUT OF THE SALE OF THIS EQUIPMENT, WHETHER DERIVED FROM WARRANTY OR OTHERWISE, SHALL BE LIMITED, AT BUNN'S SOLE OPTION AS SPECIFIED HEREIN, TO REPAIR, REPLACEMENT OR REFUND.**

In no event shall BUNN be liable for any other damage or loss, including, but not limited to, lost profits, lost sales, loss of use of equipment, claims of Buyer's customers, cost of capital, cost of down time, cost of substitute equipment, facilities or services, or any other special, incidental or consequential damages.

392, AutoPOD, AXIOM, BrewLOGIC, BrewMETER, Brew Better Not Bitter, BrewWISE, BrewWIZARD, BUNN Espresso, BUNN Family Gourmet, BUNN Gourmet, BUNN Pour-O-Matic, BUNN, BUNN with the stylized red line, BUNNlink, Bunn-O-Matic, Bunn-O-Matic, BUNNserve, BUNNSERVE with the stylized wrench design, Cool Froth, DBC, Dr. Brew stylized Dr. design, Dual, Easy Pour, EasyClear, EasyGard, FlavorGard, Gourmet Ice, Gourmet Juice, High Intensity, iMIX, Infusion Series, Intellisteam, My Café, Phase Brew, PowerLogic, Quality Beverage Equipment Worldwide, Respect Earth, Respect Earth with the stylized leaf and coffee cherry design, Safety-Fresh, savemycoffee.com, Scale-Pro, Silver Series, Single, Smart Funnel, Smart Hopper, SmartWAVE, Soft Heat, SplashGard, The Mark of Quality in Beverage Equipment Worldwide, ThermoFresh, Titan, trifacta, Velocity Brew, A Partner You Can Count On, Air Brew, Air Infusion, Beverage Bar Creator, Beverage Profit Calculator, Brew better, not bitter., BUNNSource, Coffee At Its Best, Cyclonic Heating System, Daypart, Digital Brewer Control, Nothing Brews Like a BUNN, Pouring Profits, Signature Series, Tea At Its Best, The Horizontal Red Line, Ultra are either trademarks or registered trademarks of Bunn-O-Matic Corporation.

# TABLE OF CONTENTS

ELECTRICAL AND OPERATING CONTROLS (AFPO-2) .....	32
ELECTRICAL AND OPERATING CONTROLS (AFPO-3) .....	34
HOUSING AND COVERS (AFPO-2).....	4
HOUSING AND COVERS (AFPO-3).....	6
NUMERICAL INDEX .....	36
PUMP AND PIPING (AFPO-2) .....	8
PUMP AND PIPING (AFPO-3) .....	12
PUMP COMPONENTS (AFPO-2 & 3).....	16
TWO LEVEL REFILL PROBE AND LINES (AFPO-2) .....	18
SINGLE LEVEL REFILL PROBE AND LINES (AFPO-2).....	22
TWO LEVEL REFILL PROBE AND LINES (AFPO-3) .....	24
SINGLE LEVEL REFILL PROBE AND LINES (AFPO-3).....	28

## Model Designations

AFPO-2.....	Auto refill for 2 hopper CDS with water pre-mixed
AFPO-3.....	Auto refill for 3 hopper CDS with water pre-mixed
AFPO-2 SL .....	Auto refill for 2 hopper CDS with water mixed in the hopper
AFPOA-2 SL .....	230Volt Auto refill for 2 hopper CDSA with water mixed in the hopper
AFPO-3 SL .....	Auto refill for 3 hopper CDS with water mixed in the hopper

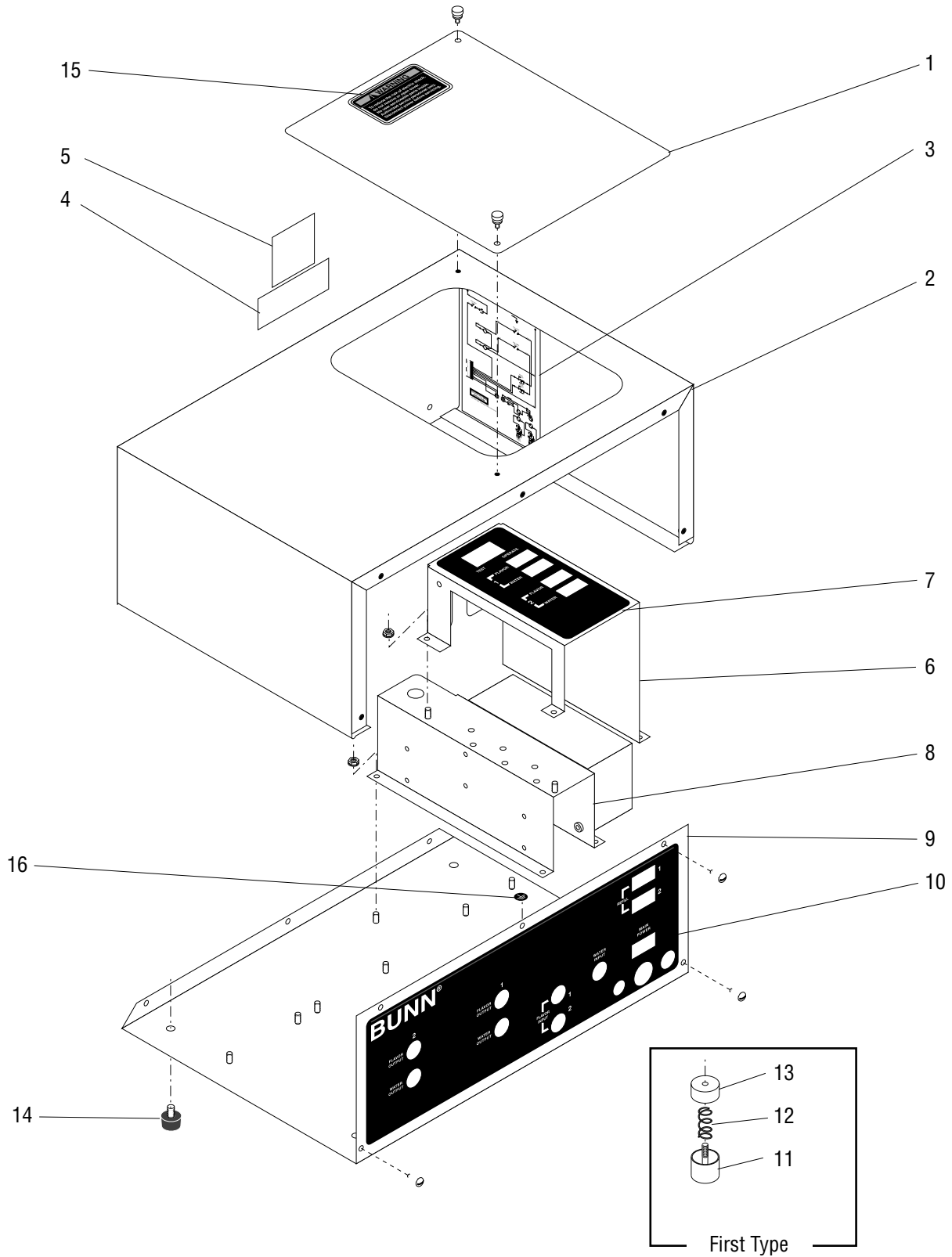

## HOUSING AND COVERS

ITEM	PART NO.	QTY.	DESCRIPTION
1	28409.0000	1	Panel, Access
	28062.0000	2	Screw, Knurled Thumb #8-32
2	28845.0000	1	Housing, Main W/Decals,120V (Includes items 3 thru 5)
	28845.0002	1	Housing, Main W/Decals,230V (Includes items 3 thru 5)
3	28814.0000	1	Decal, Electrical Schematic (120V)
	28814.0004	1	Decal, Electrical Schematic (230V)
4	00656.0001	1	Decal, COMPLIANCE TO PLUMBING CODE
5	00986.0002	1	Decal, WARNING-ELECTRICAL
6	28846.0000	1	Bracket W/Decals, Switch Mounting(Includes item 7)
	00970.0000	4	Nut, Keps #8-32
7	28414.0000	1	Decal, Brix Test
8	28403.0000	1	Bracket, Solenoid Mounting
	00970.0000	4	Nut, Keps #8-32
9	28787.1000	1	Panel W/Decals, Main Mounting (Includes item 10)
	28787.1001	1	Panel W/Decals, Main Mounting (Model SL)(Includes item 10)
	02322.0002	8	Screw, Pan Head #8-32x .375"
10	28413.0000	1	Decal, Front
	28413.0002	1	Decal, Front (Model SL)
11	00754.0001	4	Foot/Locator, Black
12	00751.0000	4	Spring
13	00752.0000	4	Foot, Cover
14	25137.0001	4	Foot (Second Type)
15	37881.0000	1	Decal, No Serviceable Parts
16	00824.0002	1	Decal, Grounding

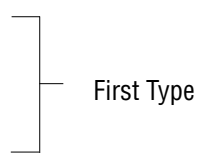

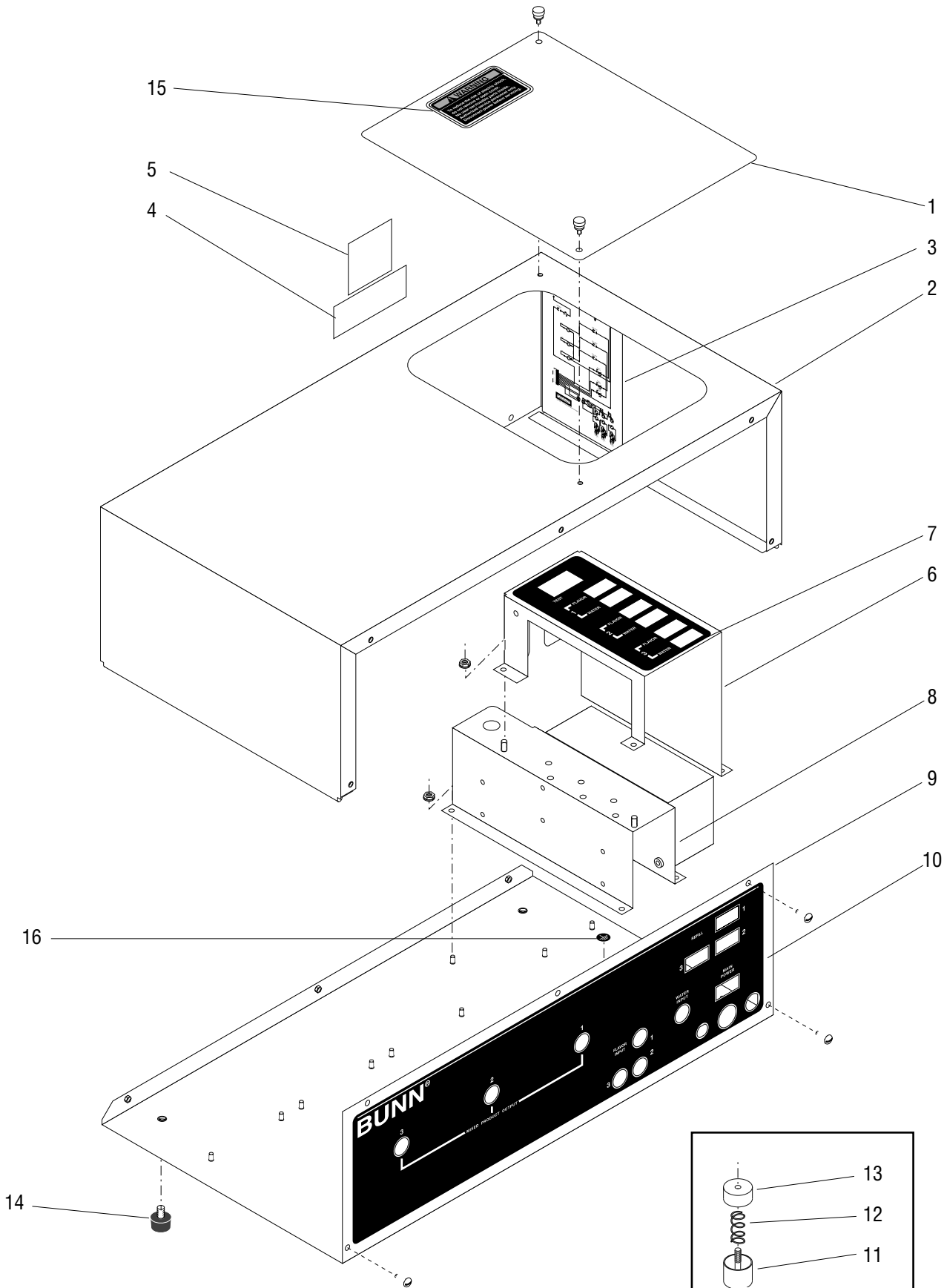

P1517

## HOUSING AND COVERS

ITEM	PART NO.	QTY.	DESCRIPTION
1	28409.0000	1	Panel, Access
	28062.0000	2	Screw, Knurled Thumb #8-32
2	29064.0001	1	Housing, Main W/Decals (Includes items 3 thru 5)
3	28814.0001	1	Decal, Electrical Schematic
4	00656.0001	1	Decal, COMPLIANCE TO PLUMBING CODE
5	00986.0002	1	Decal, WARNING-ELECTRICAL
6	28846.0001	1	Bracket W/Decals, Switch Mounting(Includes item 7)
	00970.0000	4	Nut, Keps #8-32
7	28414.0001	1	Decal, Brix Test
8	28403.0000	1	Bracket, Solenoid Mounting
	00970.0000	4	Nut, Keps #8-32
9	28827.1000	1	Panel W/Decals, Main Mounting (Includes item10)
	28827.1001	1	Panel W/Decals, Main Mounting (Model SL)(Includes item10)
	02322.0002	8	Screw, Pan Head #8-32x .375"
10	28413.0001	1	Decal, Front
	28413.0003	1	Decal, Front (Model SL)
11	00754.0001	4	Foot/Locator, Black
12	00751.0000	4	Spring
13	00752.0000	4	Foot, Cover
14	25137.0001	4	Foot (Second Type)
15	37881.0000	1	Decal, No Serviceable Parts
16	00824.0002	1	Decal, Grounding

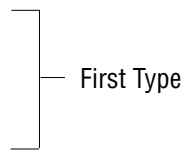

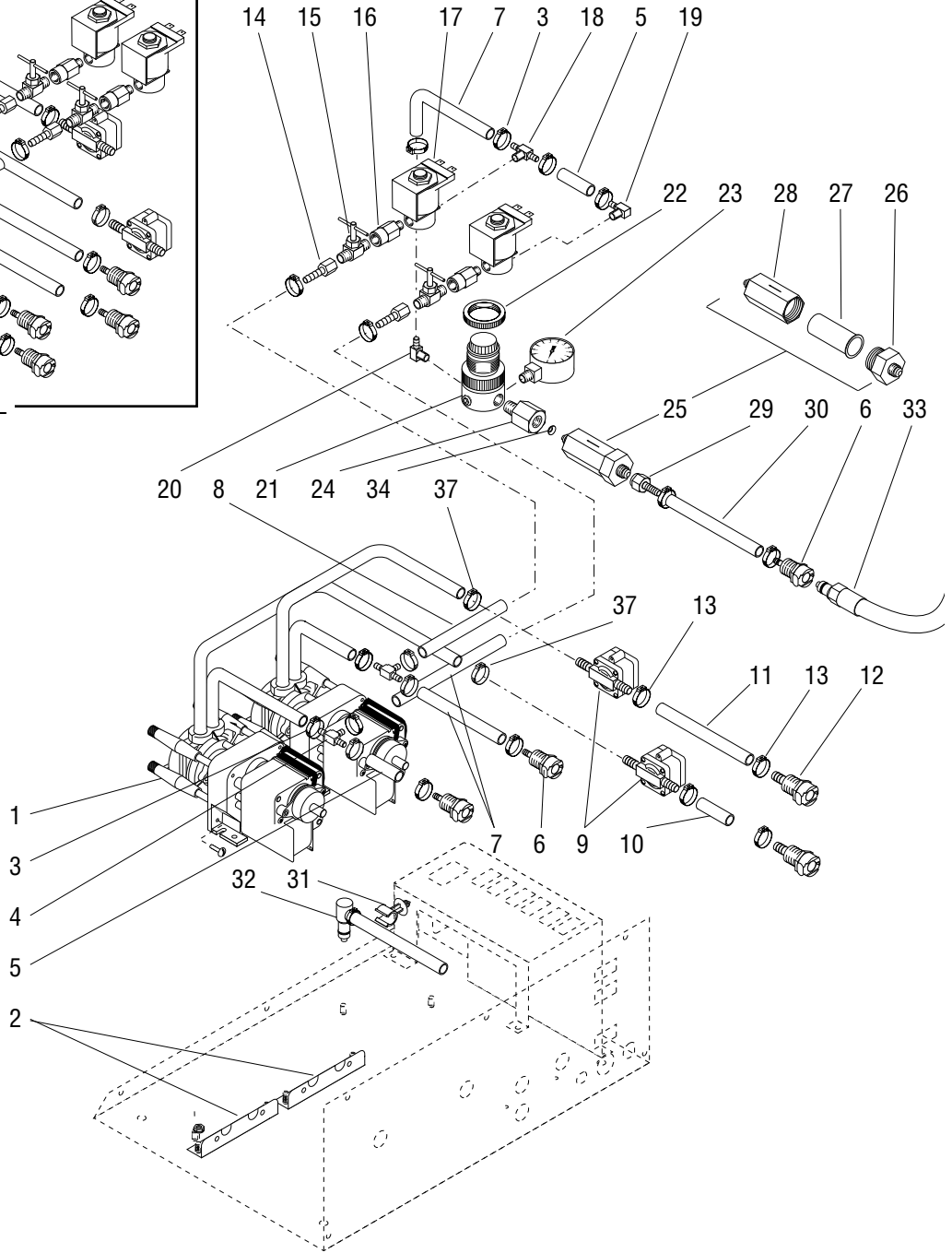
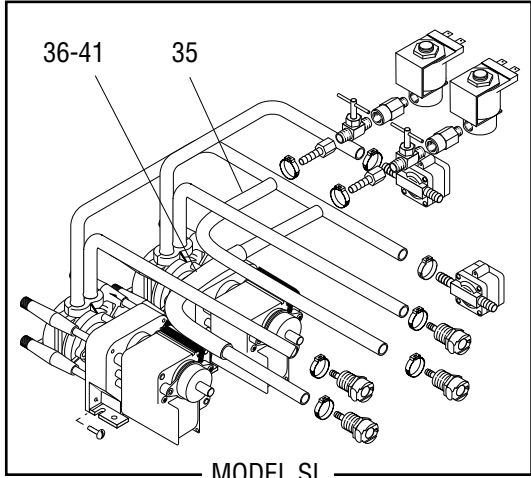



## PUMP AND PIPING

ITEM	PART NO.	QTY.	DESCRIPTION
1	----- 02367.0002	2 4	Pump Assy (See PUMP COMPONENTS) Screw, Truss Head #6-32 x .62"
2	28404.0000 00991.0000	2 4	Bracket, Pump Mounting Nut, Elastic Lock #8-32
3	21275.0006	16	Clamp .406" x .504" dia. (Four less used on Model SL)
4	22150.0001	2	Tee, Barbed .250" (Not used on Model SL)
5	38129.0003*	2	Hose .25" x 1.25" (Order item 38)(One less used on Model SL)
6	28756.1000	3	Quick Disconnect, Barbed .25" (Two additional used on Model SL)
7	38129.0007*	3	Hose .25" x 6.00" (Order item 38)(Two less used on Model SL)
8	-----	1	Hose .25" x 3.62" (Order item 38)(Not used on Model SL)
9	-----	2	Switch Assy , Vacuum (See ELECTRICAL AND OPERATING CONTROLS)
10	34325.0024*	1	Hose .375" x 1.5" (Order item 39)
11	34325.0025*	1	Hose .375" x 4.50" (Order item 39)
12	28757.0000	2	Quick Disconnect, Barbed .375"
13	21275.0003	4	Clamp .571" x .699" dia.
14	00469.0001	2	Connector, Barbed .25" x .125"FPT
15	21634.0003	2	Valve, Needle .125" MPT
16	28810.0000	2	Valve, Check .125"MPT x .125"FPT
17	-----	2	Valve, Solenoid (See ELECTRICAL AND OPERATING CONTROLS)
18	28761.0001	1	Tee, Barbed .25" x .125"MPT
19	00464.0001	1	Elbow, Barbed .25" x .125"MPT
20	25139.0000	1	Elbow, Barbed .25" x .250"MPT
21	21993.0002 00462.0001	1 1	Regulator, Water Plug, Slotted Head .125" MPT
22	28760.0000	1	Nut, Regulator Panel
23	21522.0000	1	Gauge, Pressure
24	00472.0001	1	Adapter .25"FFL x .250"MPT
25	23820.1000	1	Strainer, Water (Includes items 26 thru 28)
26	22249.0000	1	Cap, End
27	23721.0000	1	Strainer
28	-----	1	Housing, Water Strainer (Not available. Order item 25)

(Continued)

(Continued)

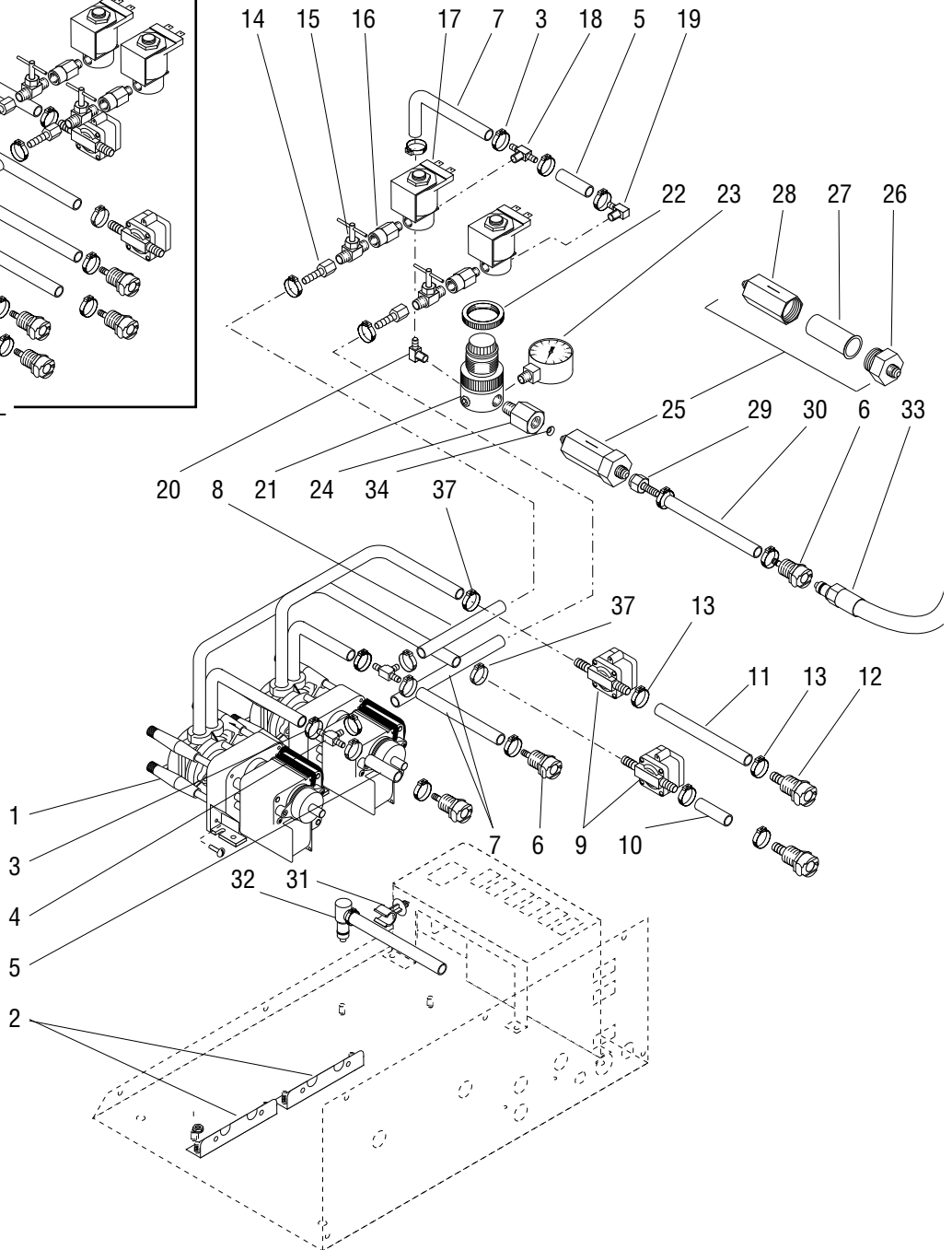
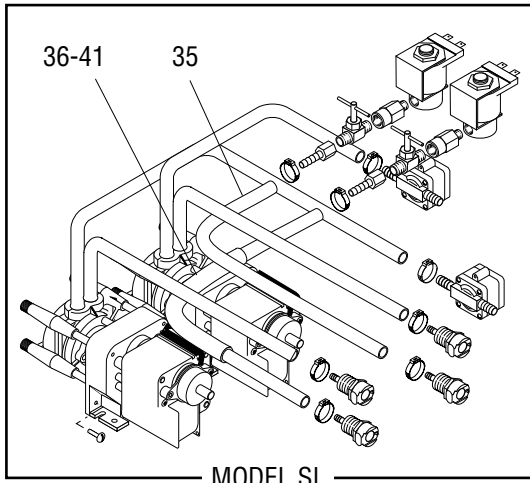

## PUMP AND PIPING

ITEM	PART NO.	QTY.	DESCRIPTION
29	00425.1000	1	Fitting, Barbed .25" x .25"FFL
30	38129.0009*	1	Hose .25" x 4.25" (Order item 38)
31	27410.0000	1	Clip, Tubing Mounting
32	28797.1000	1	Hose, Test-Brix (Includes Elbow and Clamp)
	28769.0001	1	Elbow, QDC
	21275.0003	1	Clamp .571" x .699" dia.
33	00327.0002	1	Hose Assy , Water Supply
34	24684.0000	1	Gasket .25" Flare (Copper)
35	38129.0019*	1	Hose .25" x 7.0" (Order item 38)(Model SL)
36	38129.0020*	1	Hose .25" x 10.75" (Order item 38)(Model SL)
37	21275.0000	2	Clamp .520" x .618" dia
38	38129.1002	-	Hose .25" x 120.0" (Use as required)
39	34325.1002	-	Hose .375" x 120.0" (Use as required)
40	32591.1001	-	Hose, Protective .50" x 12.0" (Use as required)
41	-----	2	Hose, Protective .50" x 9.5" (Order item 40)

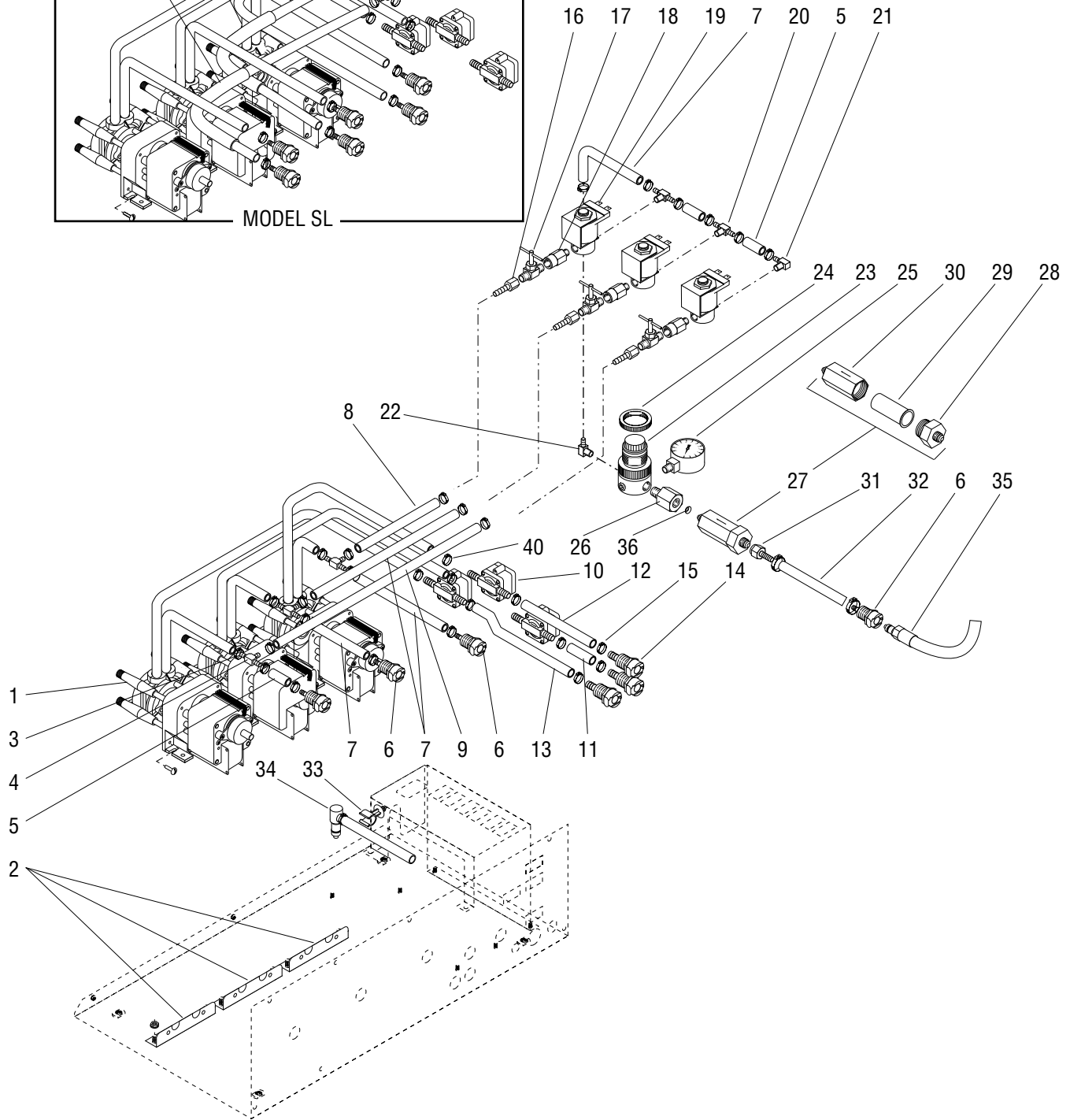
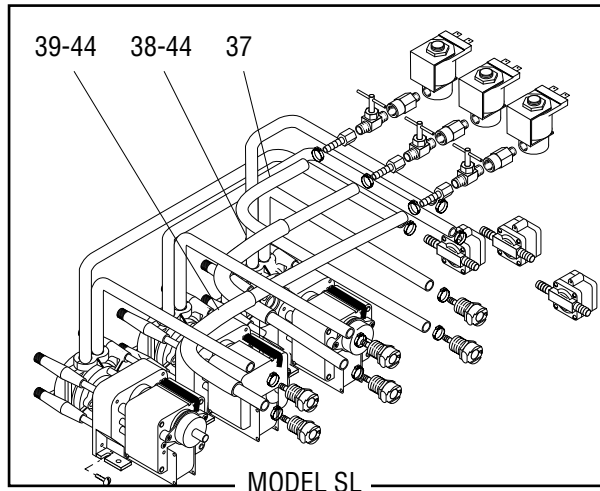

## PUMP AND PIPING

ITEM	PART NO.	QTY.	DESCRIPTION
1	----- 02367.0002	3 6	Pump Assy (See PUMP COMPONENTS) Screw, Truss Head #6-32 x .62"
2	28404.0000 00991.0000	3 6	Bracket, Pump Mounting Nut, Elastic Lock #8-32
3	21275.0006	24	Clamp .406" x .504" dia. (Six less used on Model SL)
4	22150.0001	3	Tee, Barbed .250" (Not used on Model SL)
5	38129.0003*	3	Hose .25" x 1.125" (Order item 41)(One less used on Model SL)
6	28756.1000	4	Quick Disconnect, Barbed .25" (Three additional used on Model SL)
7	38129.0007*	4	Hose .25" x 6.0" (Order item 41)(Three less used on Model SL)
8	-----	1	Hose .25" x 3.62" (Order item 41)(Not used on Model SL)
9	-----	1	Hose .25" x 10.5" (Order item 41)(Not used on Model SL)
10	-----	3	Switch Assy, Vacuum (See ELECTRICAL AND OPERATING CONTROLS)
11	34325.0024*	1	Hose .375" x 1.5" (Order item 42)
12	34325.0025*	1	Hose .375" x 4.5" (Order item 42)
13	-----	1	Hose .375" x 7.5" (Order item 42)
14	28757.0000	3	Quick Disconnect, Barbed .375"
15	21275.0003	6	Clamp .571" x .699" dia.
16	00469.0001	3	Connector, Barbed .25" x .125"FPT
17	21634.0003	3	Valve, Needle .125" MPT
18	28810.0000	3	Valve, Check .125"MPT x .125"FPT
19	-----	3	Valve, Solenoid (See ELECTRICAL AND OPERATING CONTROLS)
20	28761.0001	2	Tee, Barbed .25" x .125"MPT
21	00464.0001	1	Elbow, Barbed .25" x .125"MPT
22	25139.0000	1	Elbow, Barbed .25" x .250"MPT
23	21993.0002 00462.0001	1 1	Regulator, Water Plug, Slotted Head .125" MPT
24	28760.0000	1	Nut, Regulator Panel
25	21522.0000	1	Gauge, Pressure
26	00472.0001	1	Adapter .25"FFL x .250"MPT
27	23820.1000	1	Strainer, Water (Includes items 28 thru 30)
28	22249.0000	1	Cap, End

(Continued)

(Continued)

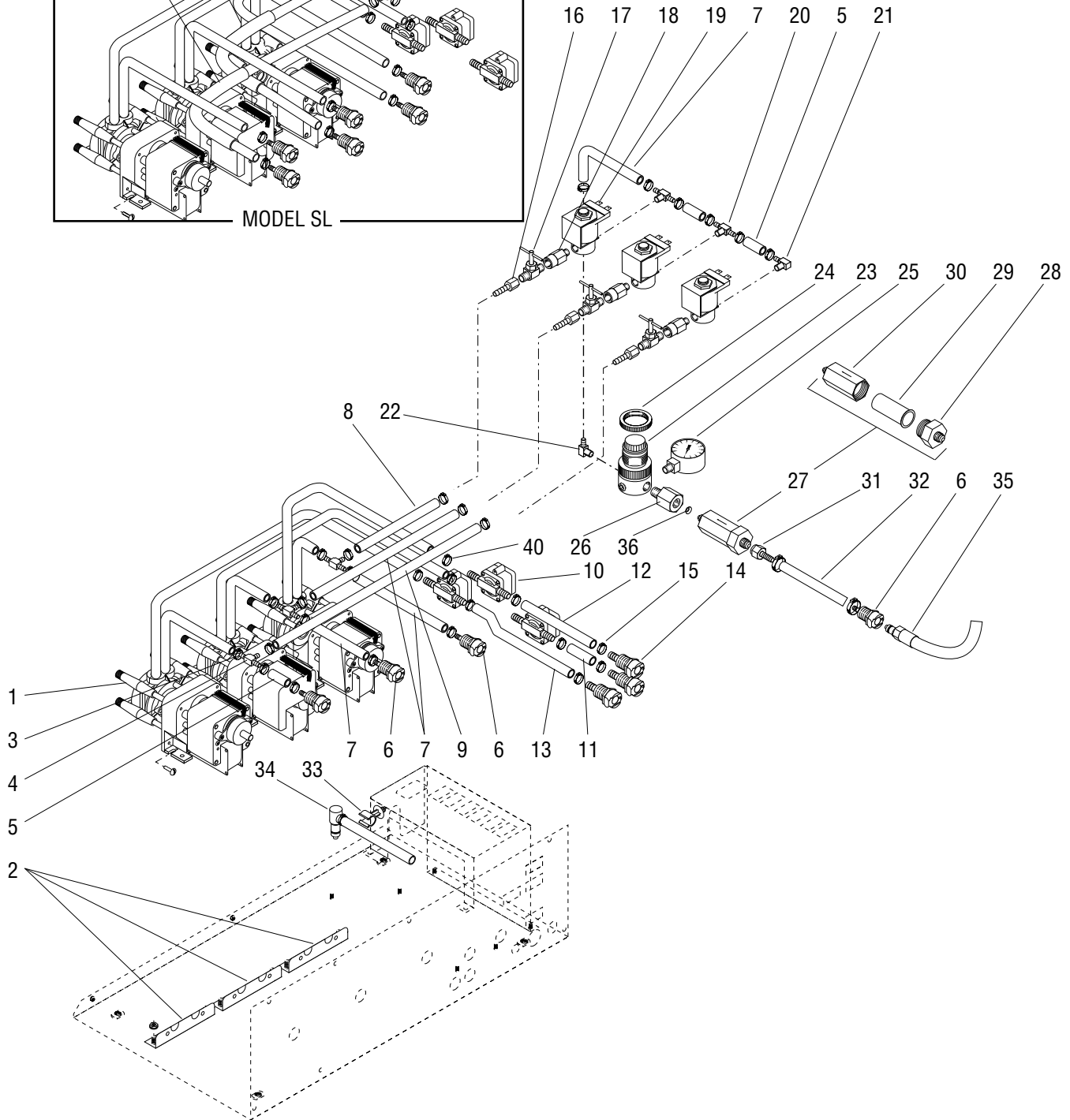
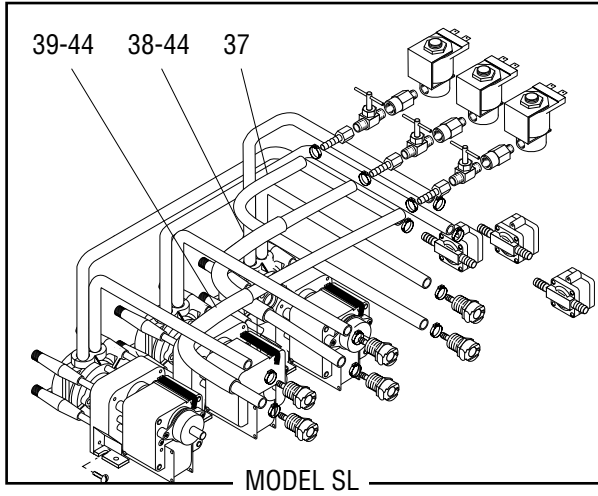

## PUMP AND PIPING

ITEM	PART NO.	QTY.	DESCRIPTION
29	23721.0000	1	Strainer
30	-----	1	Housing, Water Strainer (Not available. Order item 27)
31	00425.1000	1	Fitting, Barbed .25" x .25"FFL
32	38129.0009*	1	Hose .25" x 4.25" (Order item 41)
33	27410.0000	1	Clip, Tubing Mounting
34	28797.1000	1	Hose, Test-Brix (Includes Elbow and Clamp)
	28769.0001	1	Elbow, QDC
	21275.0002	1	Clamp .571" x .699" dia.
35	00327.0002	1	Hose Assy, Water Supply
36	24684.0000	1	Gasket .25" Flare (Copper)
37	-----	1	Hose, .25" x 9.50" (Order item 41)(Model SL)
38	38129.0020*	1	Hose, .25" x 10.75" (Order item 41)(Model SL)
39	-----	1	Hose, .25" x 15.75" (Order item 41)(Model SL)
40	21275.0002	3	Clamp .520" x .618" dia.
41	38129.1002	-	Hose, .25" x 120.0" (Use as required)
42	34325.1002	-	Hose, .375" x 120.0" (Use as required)
43	32591.1001	-	Hose, Protective .50" x 12.0" (Use as required)
44	-----	2	Hose, Protective .50" x 9.5"(Order item 43)

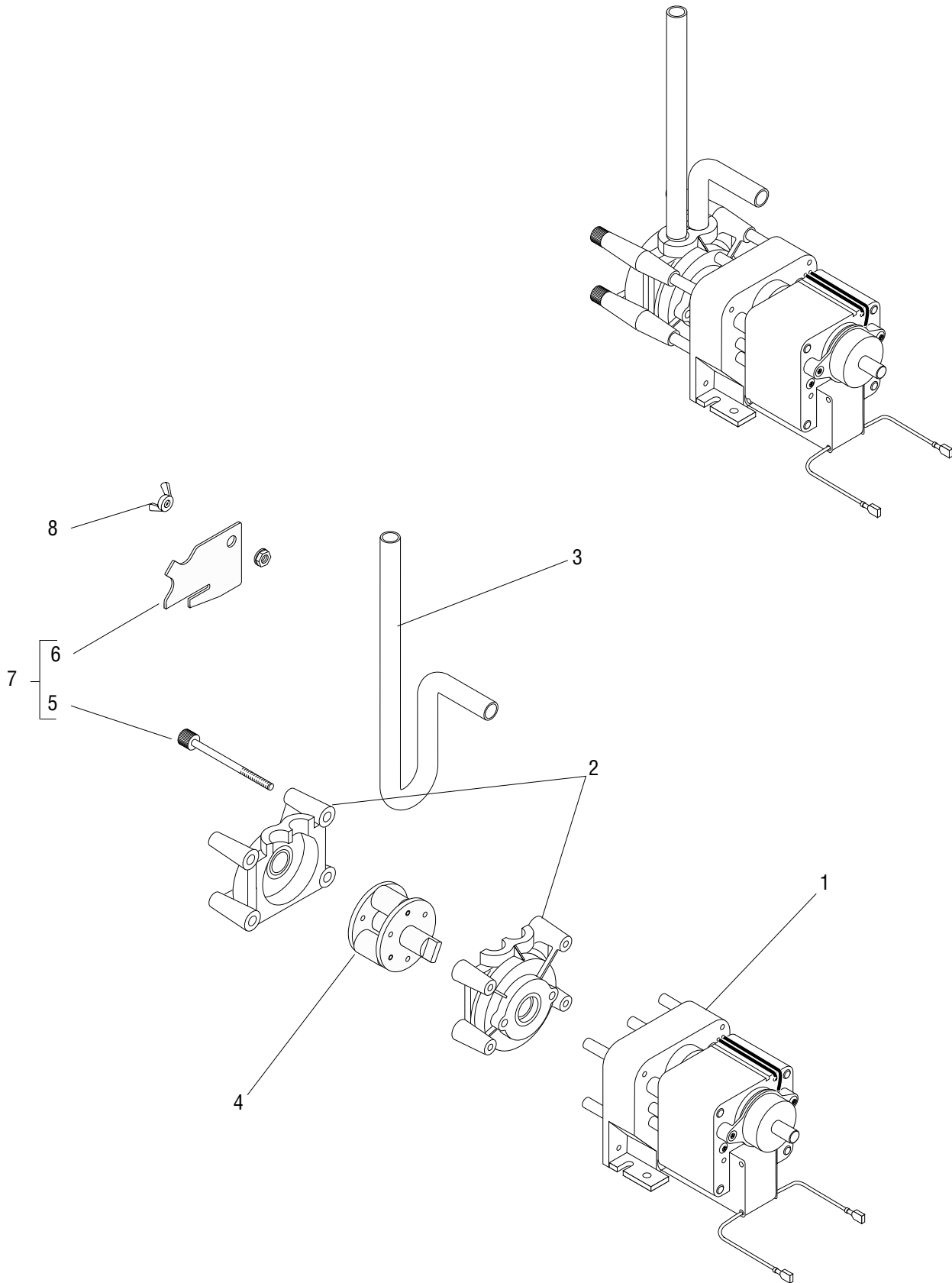



## PUMP COMPONENTS

ITEM	PART NO.	QTY.	DESCRIPTION
-	28752.1003	1	Pump Assy, HPR-1 (120V)(Model SL)
	28752.1004	1	Pump Assy, HPR-2 (120V)(Model SL)
	28752.1005	1	Pump Assy, HPR-3 (120V)(Model SL)
			} Includes items 1-9
1	28762.0000	1	Motor, Pump (120V)
	28762.0001	1	Motor, Pump (230V)
2	28759.0000	1	Head Assy, Pump (Includes Items 4 and 5)
3	28755.1001	1	Hose Assy, HPR-1 .25" ID x 15.85"
	28755.1002	1	Hose Assy, HPR-2 .25" ID x 22.20"
	28755.1004	1	Hose Assy, HPR-3 .25" ID x 28.50"
	28755.1002	1	Hose Assy, HPR-1 .25" ID x 22.20" (Model SL)
	28755.1005	1	Hose Assy, HPR-2 .25" ID x 30.00" (Model SL)
	28755.1006	1	Hose Assy, HPR-3 .25" ID x 31.00" (Model SL)
4	28794.0000	1	Rotor, Pump
5	01370.0001	4	Screw, Pan Head #8-32 x 2.45"
6	-----	1	Key, Hose Installation (Not Serviced. Order item 7)
7	28758.0000	1	Kit, Hardware (Includes Items 5 and 6)
8	01386.0000	1	Wing Nut, SST #8-32
	00970.0000	1	Nut, Keps #8-32

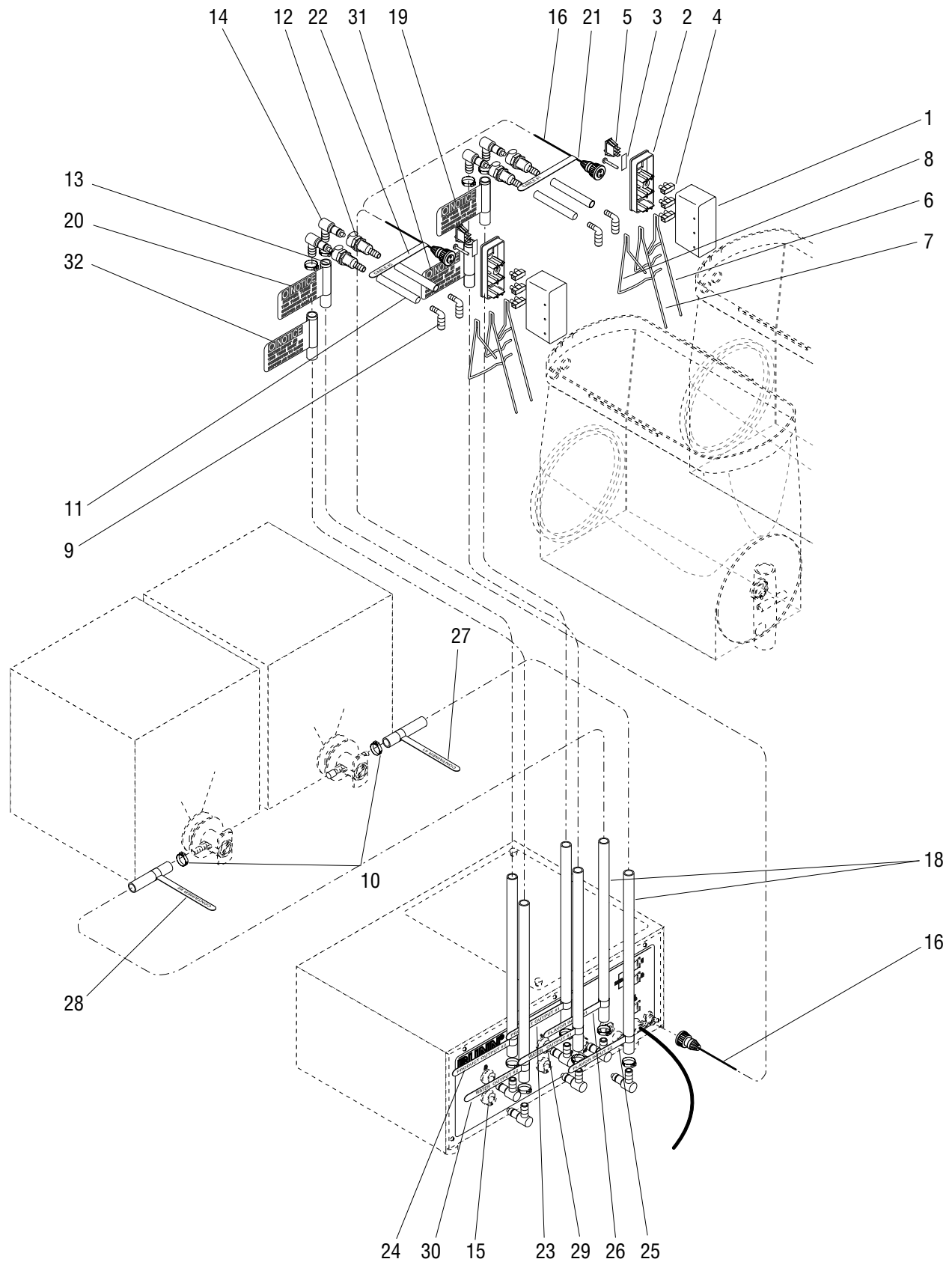

## TWO LEVEL REFILL PROBE AND LINES

ITEM	PART NO.	QTY.	DESCRIPTION
-	28767.1000	2	Probe Assy, Hopper Refill (Includes items 1 thru 8 & 17)
1	28446.0000	2	Housing, Probe
2	28447.0000	2	Cover, Housing
	01360.0002	2	Screw, Pan Head #6 x .375"
3	28415.0000	2	Decal, Sensor
4	28781.1000	6	Block, Terminal
5	27437.0000	2	Switch,ON/OFF/ON
6	28450.0000	2	Probe, Long 5.92" (CDS)
	28450.0001	2	Probe, Long 5.92" (ULTRA)
7	28451.0000	2	Probe, Center 5.92" (CDS)
	28451.0001	2	Probe, Long 5.92" (ULTRA)
8	28452.0000	2	Probe, Short 3.65" (CDS)
	28452.0001	2	Probe, Short 3.65" (ULTRA)
9	28770.0000	2	Elbow, Barbed .25" x .50" (Two additional used on Model SL)
10	21275.0003	8	Clamp .571" x .699" dia (Four additional used on Model SL)
11	-----	2	Hose .25" x 1.25"(Order item 33)(Two additional used on Model SL)
12	28756.1000	2	Quick Disconnect, Barbed .25" (Two additional used on Model SL)
13	-----	2	Hose, Product Output .375" x 0.0"(Order item 34)(Two additional used on Model SL)
14	28769.0001	6	Elbow, QDC (Two additional used on Model SL)
15	-----	2	Quick Disconnect (See PUMP AND PIPING)(Two additional used on Model SL)
16	28410.0000	1	Cable Assy, Console to Probe Housing
17	28766.0000	2	Wire Assy, Probe Housing (Not Illustrated)
18	-----	2	Hose, Flavor Input .375" x 0.0" (Order item 34)
19	-----	1	Decal, Flavor Input #1 (Order item 35)
20	-----	1	Decal, Flavor Input #2 (Order item 35)
21	-----	1	Decal, Cable #1 (Order item 35)
22	-----	1	Decal, Cable #2 (Order item 35)
23	-----	1	Decal, Tube-Product Output #1 (Order item 35)
24	-----	1	Decal, Tube-Product Output #2 (Order item 35)
25	-----	1	Decal, Flavor Input #1 (Order item 35)
26	-----	1	Decal, Flavor Input #2 (Order item 35)
27	-----	1	Decal, Container #1 (Order item 35)
28	-----	1	Decal, Container #2 (Order item 35)

(Continued)

(Continued)

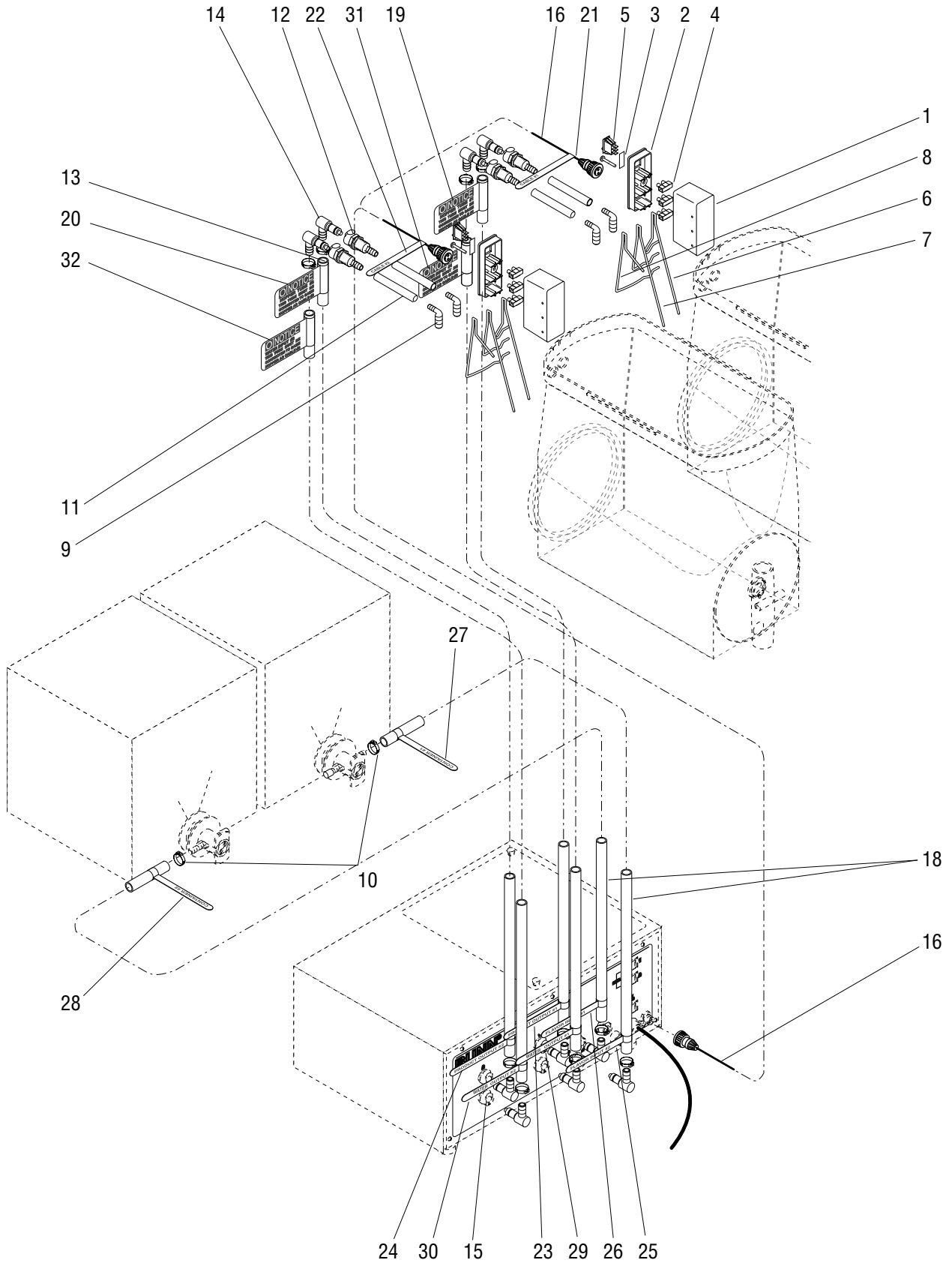

TWO LEVEL REFILL PROBE AND LINES

ITEM	PART NO.	QTY.	DESCRIPTION
29	-----	1	Decal, Water Output #1 (Order item 36)
30	-----	1	Decal, Water Output #2 (Order item 36)
31	-----	1	Decal, Water Input #1 (Order item 36)
32	-----	1	Decal, Water Input #2 (Order item 36)
33	32745.1002	-	Hose .25" x 120.0"(Use as required)
34	32759.1002	-	Hose .375" x 120.0"(Use as required)
35	28417.0000	1	Decal Kit (Includes items 19 thru 28)
36	29791.0000	1	Decal Kit (Includes items 29 thru 32)(Model SL)

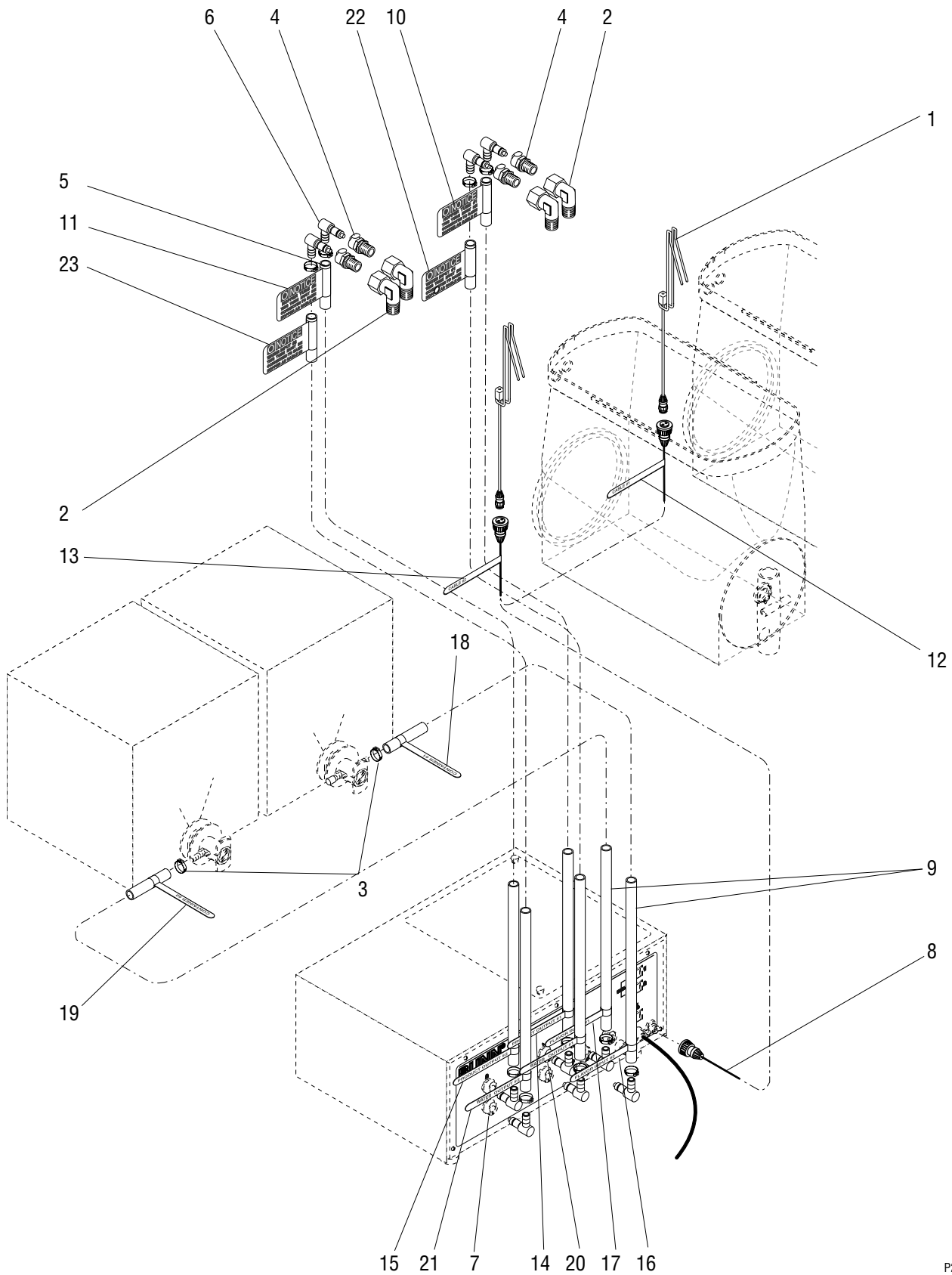

## SINGLE LEVEL REFILL PROBE AND LINES

ITEM	PART NO.	QTY.	DESCRIPTION
1	29810.0000	2	Probe Assy., Single Level
2	29843.0000	2	Elbow (Two additional used on Model SL)
3	21275.0003	8	Clamp .571" x .699" dia (Order item 27)(Four additional used on Model SL)
4	28756.1001	2	Quick Disconnect (Two additional used on Model SL)
5	-----	2	Hose, Product Output .375" x 0.0"(Order item 24)(Two additional used on Model SL)
6	28769.0001	6	Elbow, QDC (Two additional used on Model SL)
7	-----	2	Quick Disconnect (See PUMP AND PIPING)(Two additional used on Model SL)
8	28410.0000	1	Cable Assy, Console to Probe
9	-----	2	Hose, Flavor Input .375" x 0.0" (Order item 24)
10	-----	1	Decal, Flavor Input #1 (Order item 25)
11	-----	1	Decal, Flavor Input #2 (Order item 25)
12	-----	1	Decal, Cable #1 (Order item 25)
13	-----	1	Decal, Cable #2 (Order item 25)
14	-----	1	Decal, Tube-Product Output #1 (Order item 25)
15	-----	1	Decal, Tube-Product Output #2 (Order item 25)
16	-----	1	Decal, Flavor Input #1 (Order item 25)
17	-----	1	Decal, Flavor Input #2 (Order item 25)
18	-----	1	Decal, Container #1 (Order item 25)
19	-----	1	Decal, Container #2 (Order item 25)
20	-----	1	Decal, Water Output #1 (Order item 26)
21	-----	1	Decal, Water Output #2 (Order item 26)
22	-----	1	Decal, Water Input #1 (Order item 26)
23	-----	1	Decal, Water Input #2 (Order item 26)
24	32759.1002	-	Hose .375" x 120.0" (Use as required)
25	28417.0000	1	Decal Kit (Includes items 10 thru 19)
26	29791.0000	1	Decal Kit (Includes items 20 thru 23)(Model SL)

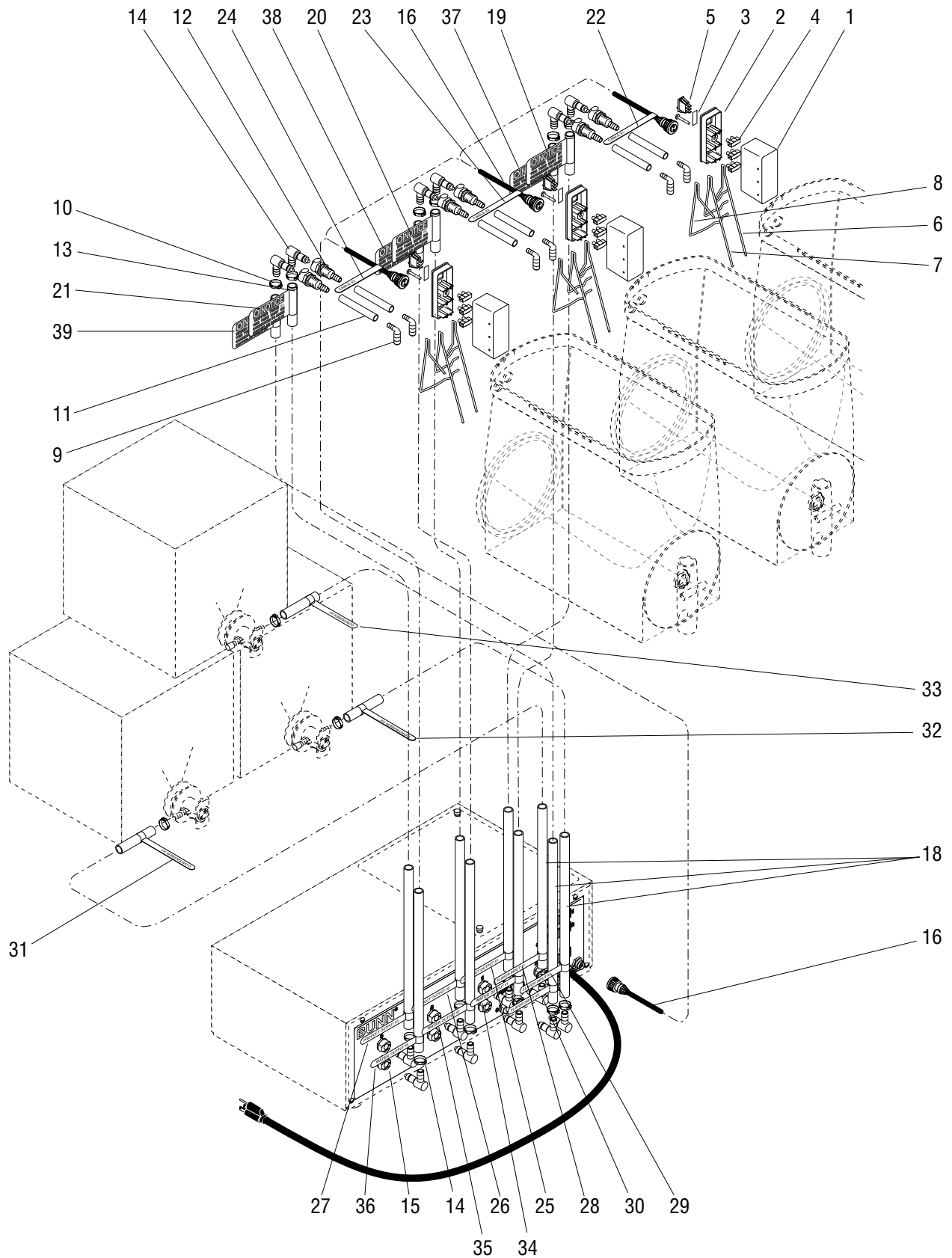



## TWO LEVEL REFILL PROBE AND LINES

ITEM	PART NO.	QTY.	DESCRIPTION
-	28767.1000	3	Probe Assy, Hopper Refill (Includes items 1 thru 8 & 17)
1	28446.0000	3	Housing, Probe
2	28447.0000	3	Cover, Housing
	01360.0002	3	Screw, Pan Head #6 x .375"
3	28415.0000	3	Decal, Sensor
4	28781.1000	9	Block, Terminal
5	27437.0000	3	Switch, ON/OFF/ON
6	28450.0000	2	Probe, Long 5.92" (CDS)
	28450.0001	2	Probe, Long 5.92" (ULTRA)
7	28451.0000	2	Probe, Center 5.92" (CDS)
	28451.0001	2	Probe, Long 5.92" (ULTRA)
8	28452.0000	2	Probe, Short 3.65" (CDS)
	28452.0001	2	Probe, Short 3.65" (ULTRA)
9	28770.0000	3	Elbow, Barbed .25" x .50" (Three additional used on Model SL)
10	21275.0003	12	Clamp .571" x .699" dia (Six additional used on Model SL)
11	-----	3	Hose .25" x 1.25"(Order item 40) (Three additional used on Model SL)
12	28756.1000	3	Quick Disconnect, Barbed .25" (Three additional used on Model SL)
13	-----	3	Hose, Product Output .375" x 00"(Order item 41)(Three additional used on Model SL)
14	28769.0001	9	Elbow, QDC (Three additional used on Model SL)
15	-----	3	Quick Disconnect (See PUMP AND PIPING) (Six additional used on Model SL)
16	28410.0001	1	Cable Assy, Console to Probe Housing
17	28766.0000	3	Wire Assy, Probe Housing (Not Illustrated)
18	-----	3	Hose, Flavor Input .375" x 00.0" (Order item 41)
19	-----	1	Decal, Flavor Input #1 (Order item 42)
20	-----	1	Decal, Flavor Input #2 (Order item 42)
21	-----	1	Decal, Flavor Input #3 (Order item 42)
22	-----	1	Decal, Cable #1 (Order item 42)
23	-----	1	Decal, Cable #2 (Order item 42)
24	-----	1	Decal, Cable #3 (Order item 42)
25	-----	1	Decal, Tube-Product Output #1 (Order item 42)
26	-----	1	Decal, Tube-Product Output #2 (Order item 42)
27	-----	1	Decal, Tube-Product Output #3 (Order item 42)

(Continued)

(Continued)

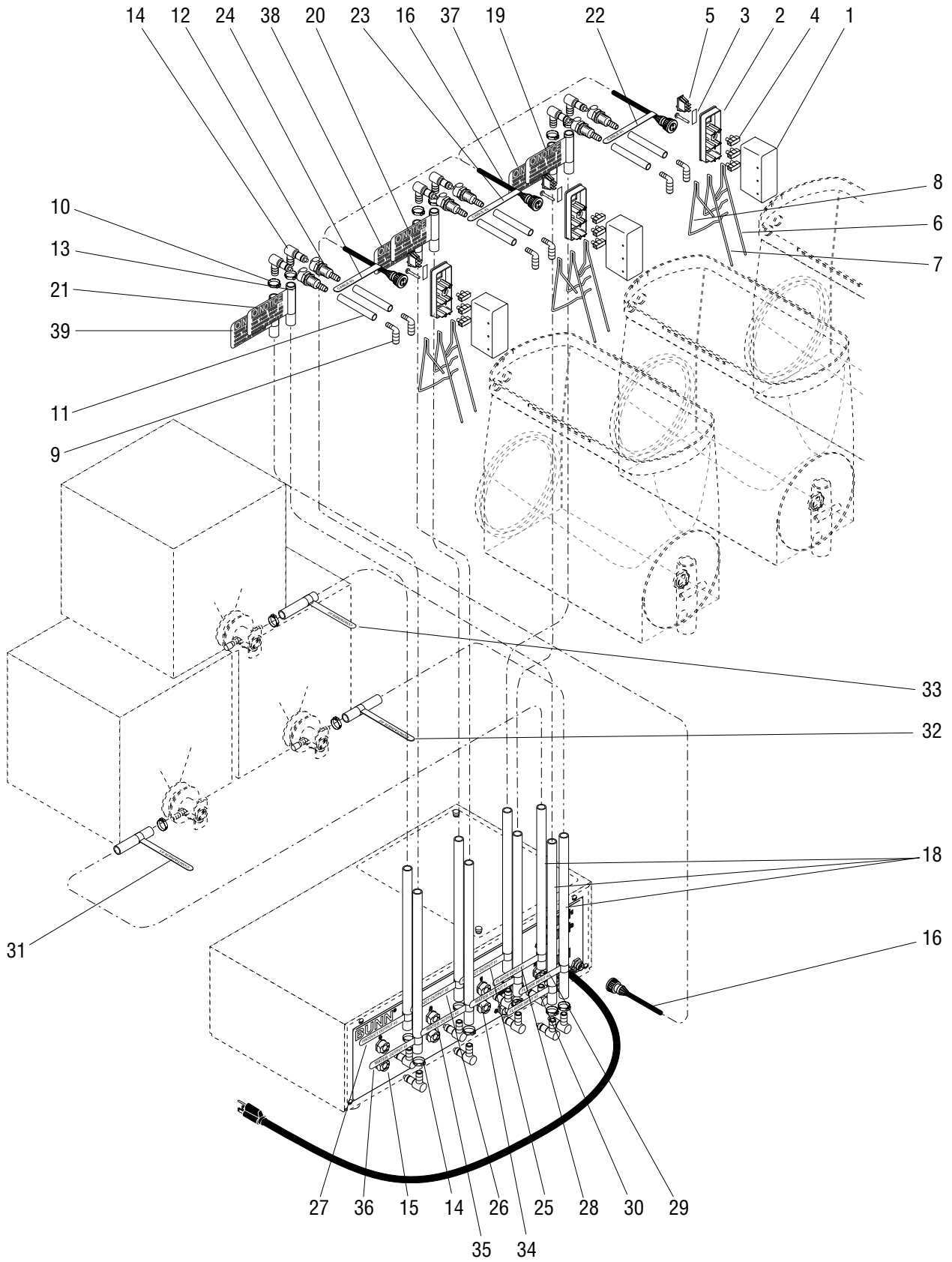

## TWO LEVEL REFILL PROBE AND LINES

ITEM	PART NO.	QTY.	DESCRIPTION
28	-----	1	Decal, Flavor Input #1 (Order item 42)
29	-----	1	Decal, Flavor Input #2 (Order item 42)
30	-----	1	Decal, Flavor Input #3 (Order item 42)
31	-----	1	Decal, Container #1 (Order item 42)
32	-----	1	Decal, Container #2 (Order item 42)
33	-----	1	Decal, Container #3 (Order item 42)
34	-----	1	Decal, Water Output #1 (Order item 43)(Model SL)
35	-----	1	Decal, Water Output #2 (Order item 43)(Model SL)
36	-----	1	Decal, Water Output #3 (Order item 43)(Model SL)
37	-----	1	Decal, Water Input #1 (Order item 43)(Model SL)
38	-----	1	Decal, Water Input #2 (Order item 43)(Model SL)
39	-----	1	Decal, Water Input #3 (Order item 43)(Model SL)
40	32745.1002	-	Hose .25" x 120.0" (Use as required)
41	32759.1002	-	Hose .375" x 120.0" (Use as required)
42	28417.0000	1	Decal Kit (Includes items 19 thru 33)
43	29791.0000	1	Decal Kit (Includes items 34 thru 39)(Model SL)

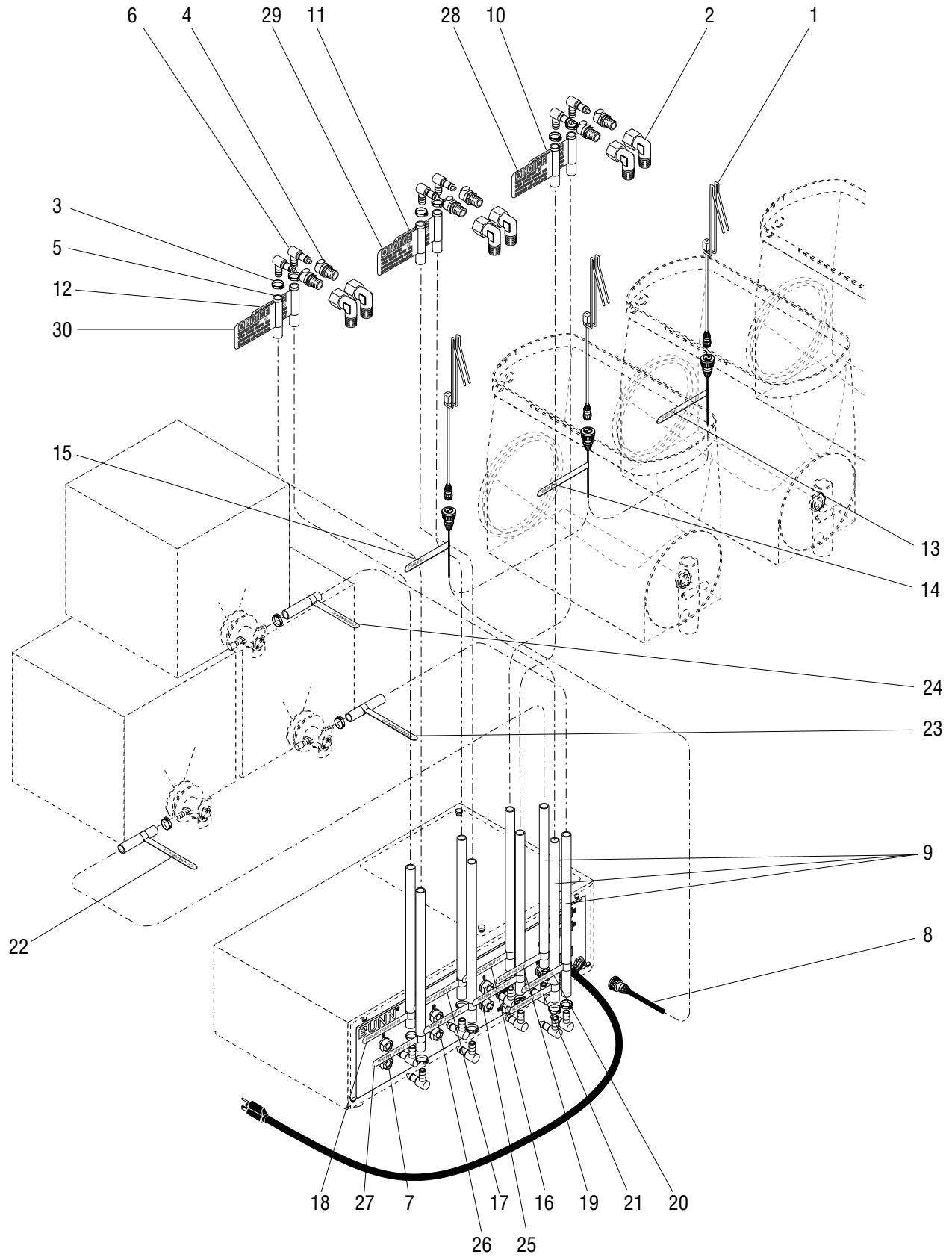

## SINGLE LEVEL REFILL PROBE AND LINES

ITEM	PART NO.	QTY.	DESCRIPTION
1	29810.0000	3	Probe Assy, Single Level
2	29843.0000	3	Elbow (Three additional used on Model SL)
3	21275.0003	12	Clamp .571" x .699" dia (Six additional used on Model SL)
4	28756.1001	3	Quick Disconnect (Three additional used on Model SL)
5	-----	3	Hose, Product Output .375" x 00"(Order item 31)(Three additional used on Model SL)
6	28769.0001	9	Elbow, QDC (Three additional used on Model SL)
7	-----	3	Quick Disconnect (See PUMP AND PIPING) (Six additional used on Model SL)
8	28410.0001	1	Cable Assy, Console to Probe Housing
9	-----	3	Hose, Flavor Input .375" x 00.0" (Order item 31)
10	-----	1	Decal, Flavor Input #1 (Order item 32)
11	-----	1	Decal, Flavor Input #2 (Order item 32)
12	-----	1	Decal, Flavor Input #3 (Order item 32)
13	-----	1	Decal, Cable #1 (Order item 32)
14	-----	1	Decal, Cable #2 (Order item 32)
15	-----	1	Decal, Cable #3 (Order item 32)
16	-----	1	Decal, Tube-Product Output #1 (Order item 32)
17	-----	1	Decal, Tube-Product Output #2 (Order item 32)
18	-----	1	Decal, Tube-Product Output #3 (Order item 32)
19	-----	1	Decal, Flavor Input #1 (Order item 32)
20	-----	1	Decal, Flavor Input #2 (Order item 32)
21	-----	1	Decal, Flavor Input #3 (Order item 32)
22	-----	1	Decal, Container #1 (Order item 32)
23	-----	1	Decal, Container #2 (Order item 32)
24	-----	1	Decal, Container #3 (Order item 32)
25	-----	1	Decal, Water Output #1 (Order item 33)(Model SL)
26	-----	1	Decal, Water Output #2 (Order item 33)(Model SL)
27	-----	1	Decal, Water Output #3 (Order item 33)(Model SL)
28	-----	1	Decal, Water Input #1 (Order item 33)(Model SL)
29	-----	1	Decal, Water Input #2 (Order item 33)(Model SL)

(Continued)

(Continued)

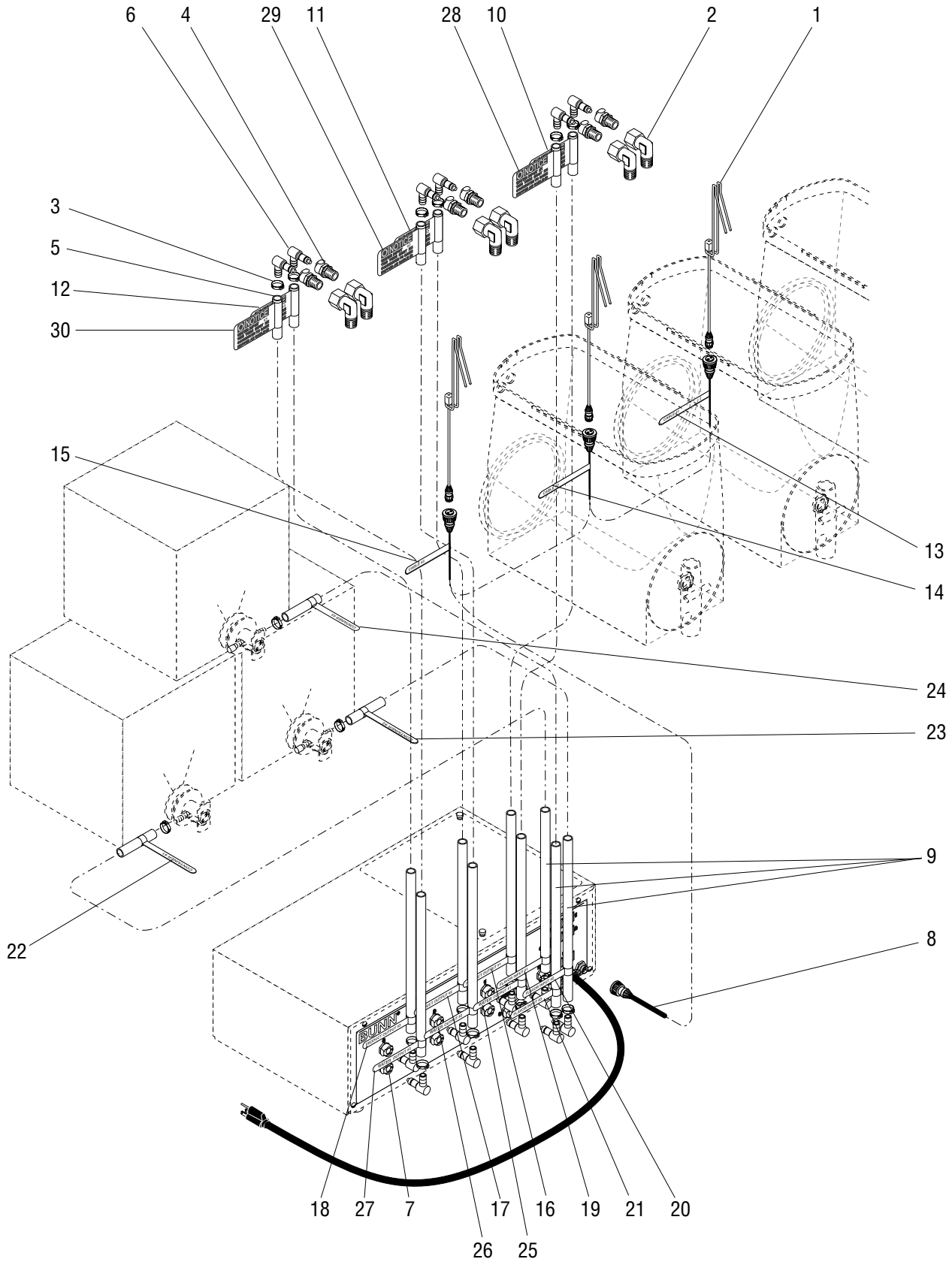

## SINGLE LEVEL REFILL PROBE AND LINES

ITEM	PART NO.	QTY.	DESCRIPTION
30	-----	1	Decal, Water Input #3 (Order item 33)(Model SL)
31	32759.1002	-	Hose .375" x 120.0" (Use as required)
32	28417.0000	1	Decal Kit (Includes items 10 thru 24)
33	29791.0000	1	Decal Kit (Includes items 25 thru 30)(Model SL)

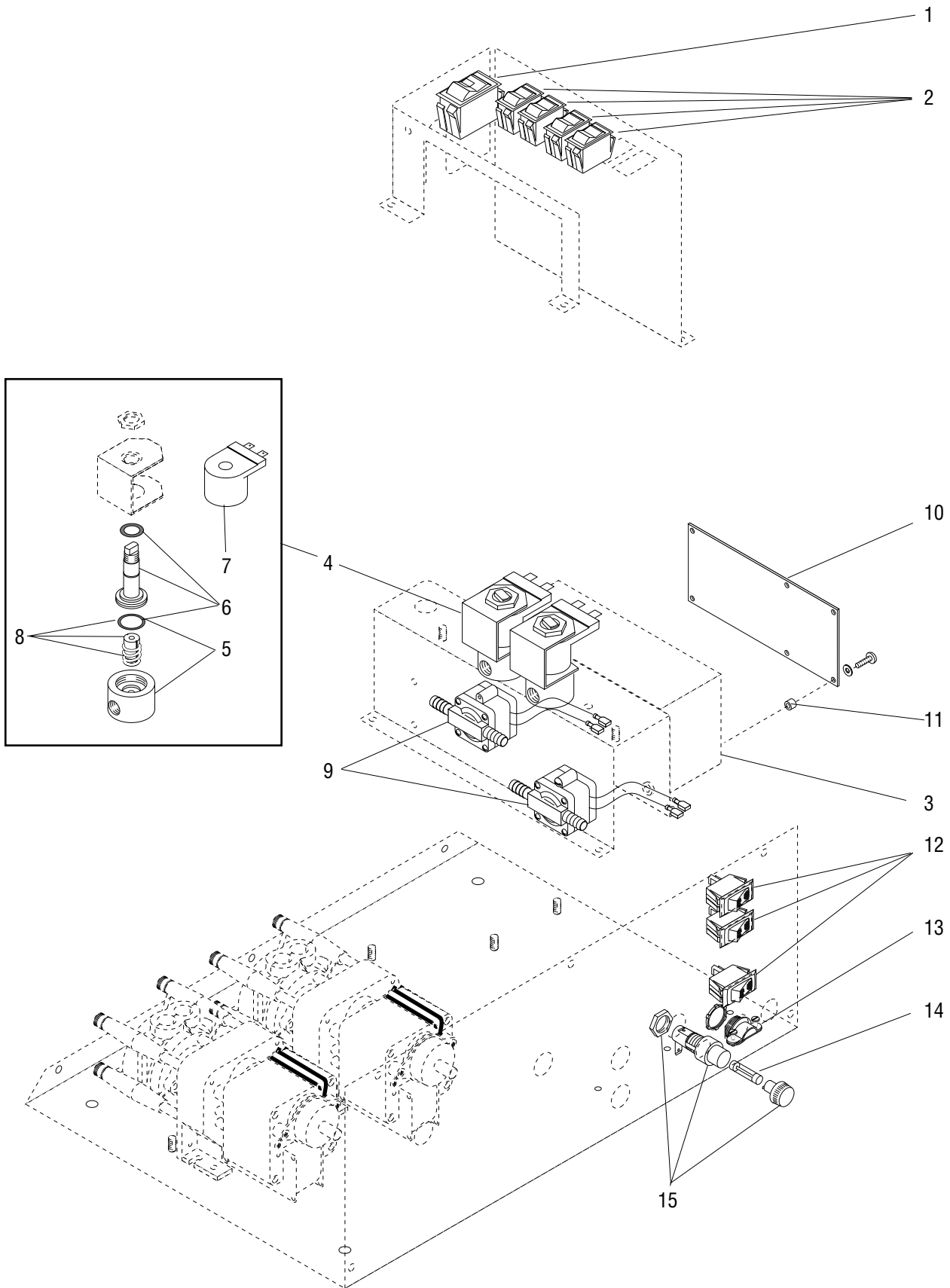



## ELECTRICAL AND OPERATING CONTROLS

ITEM	PART NO.	QTY.	DESCRIPTION
1	03356.1000	1	Switch (BRN), TEST/OPERATE
	03356.1001	1	Switch (BLK), TEST/OPERATE
2	01063.0000	4	Switch, Momentary Start
3	-----	1	Shield, PC Board (See HOUSINGS AND COVERS)
4	01085.0002	2	Solenoid Valve (120V)(Includes items 5 thru 8)
	01975.0000	2	Solenoid Valve (230V)(Includes items 5 thru 7)
	01327.0000	4	Screw, Pan Head #10-32 x .375"
	01502.0000	4	Lockwasher, Split #10
5	28479.0000	1	Base Kit, Solenoid Valve (120V)(Includes O-ring)
	01079.0000	1	Base, Solenoid Valve (230V)
6	28481.0000	1	Guide Kit (120V)(Includes Washer and O-ring)
	01116.0000	1	Guide (230V)
7	28480.0000	1	Coil, Solenoid Valve (120V)
	01100.0000	1	Coil, Solenoid Valve (230V)
8	01111.0002	1	Solenoid Valve Repair Kit (120V)(Includes Plunger, Spring and O-ring)
9	28751.0000	2	Switch, Vacuum Controlled
	02362.0000	4	Screw, Pan Head #4-40 x 1.25"
10	28396.1000	1	Circuit Board, Control (120V)
	28396.1001	1	Circuit Board, Control (230V)
	01303.0000	6	Screw, Pan Head #4-40 x .50"
	01525.0000	6	Washer, Retainer
11	01533.0004	6	Spacer
12	04786.0002	3	Switch, ON/OFF
13	01685.0000	1	Connector, Cord
14	27035.0001	1	Fuse, 10 amp
15	03231.0000	1	Holder Assy, Fuse (Includes Cap and Mounting Nut)
16	28412.0000	1	Wiring Harness, Main
17	-----	1	Splice, Bell (Not serviced)
18	20630.0016	1	Cord, Power (120V)
	32445.0001	1	Cord, Power (230V)

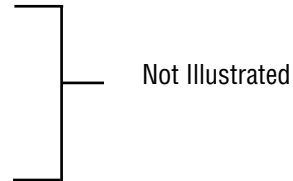

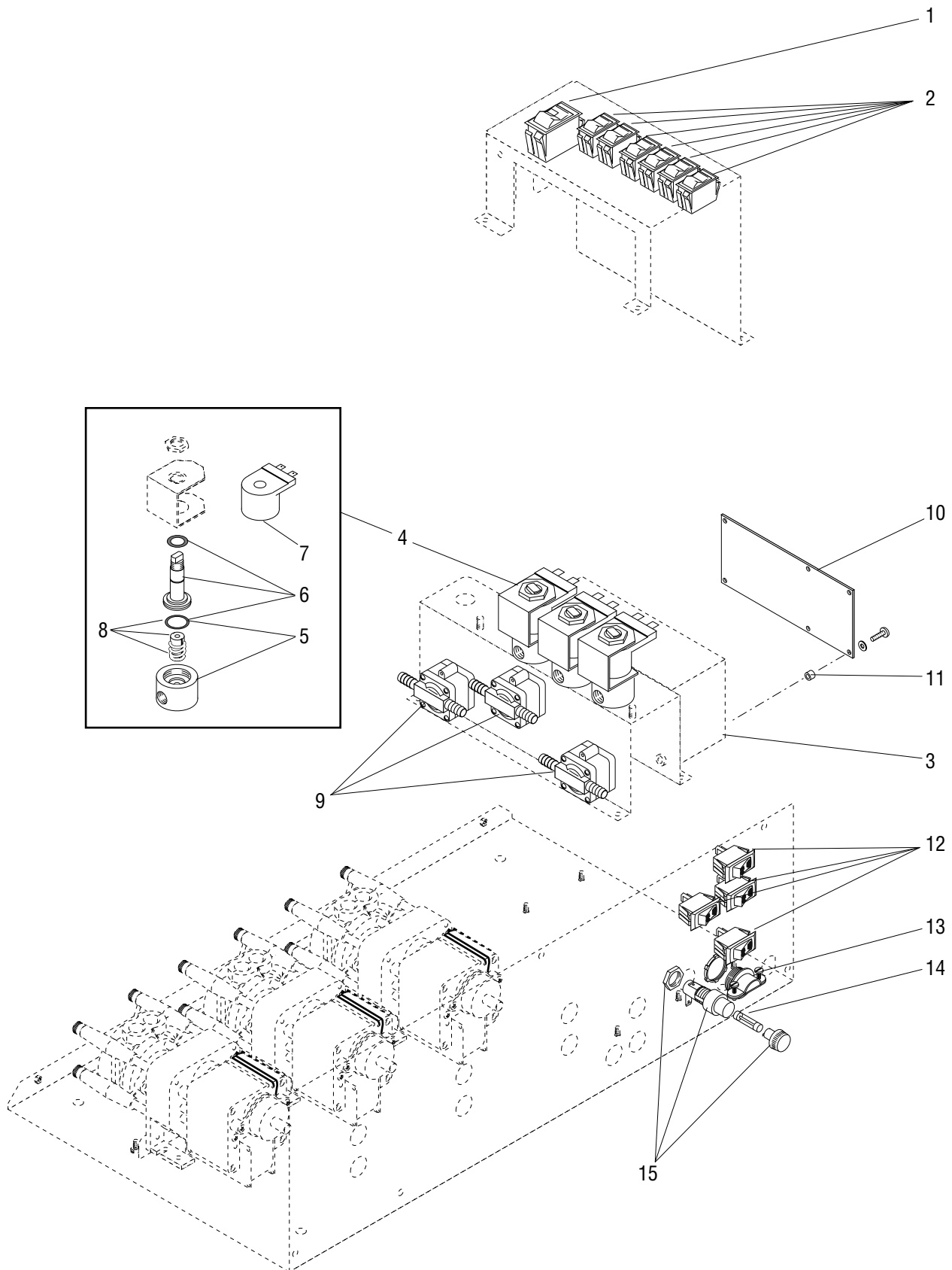

## ELECTRICAL AND OPERATING CONTROLS

ITEM	PART NO.	QTY.	DESCRIPTION
1	03356.1000	1	Switch (BRN), TEST/OPERATE
	03356.1001	1	Switch (BLK), TEST/OPERATE
2	01063.0000	6	Switch, Momentary Start
3	-----	1	Shield, PC Board (See HOUSINGS AND COVERS)
4	01085.0002	3	Solenoid Valve (Includes items 5 thru 8)
	01327.0000	6	Screw, Pan Head #10-32 x .375"
	01502.0000	6	Lockwasher, Split #10
5	28479.0000	1	Solenoid Valve Base Kit (Includes O-ring)
6	28481.0000	1	Guide Kit (Includes Washer and O-ring)
7	28480.0000	1	Solenoid Valve Coil
8	01111.0002	1	Solenoid Valve Repair Kit (Includes Plunger, Spring and O-ring)
9	28751.0000	3	Switch, Vacuum Controlled
	02362.0000	6	Screw, Pan Head #4-40 x 1.25"
10	28396.1000	1	Circuit Board, Control
	01303.0000	6	Screw, Pan Head #4-40 x .50"
	01525.0000	6	Washer, Retaining
11	01533.0004	6	Spacer
12	04786.0002	4	Switch, ON/OFF
13	01685.0000	1	Connector, Cord
14	27035.0001	1	Fuse, 10 amp
15	03231.0000	1	Holder Assy, Fuse (Includes Cap and Mounting Nut)
16	28837.0000	1	Wiring Harness, Main
17	-----	1	Splice, Bell (Not Serviced)
18	20630.0016	1	Cord, Power

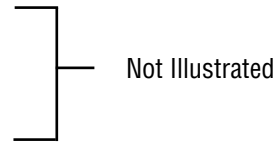

NUMERICAL INDEX

PART NO.	PAGE NO.	PART NO.	PAGE NO.	PART NO.	PAGE NO.	PART NO.	PAGE NO.
00327.0002	11,15	27410.0000	11,15	28787.1000	5		
00425.1000	11,15	27437.0000	19,25	28787.1001	5		
00462.0001	9,13	28062.0000	5,7	28794.0000	17		
00464.0001	9,13	28396.1000	33,35	28797.1000	11,15		
00469.0001	9,13	28396.1001	33	28810.0000	9,13		
00472.0001	9,13	28403.0000	5,7	28814.0000	5		
00656.0001	5,7	28404.0000	9,13	28814.0001	7		
00751.0000	5,7	28409.0000	5,7	28814.0004	5		
00752.0000	5,7	28410.0000	19,23	28827.1000	7		
00754.0001	5,7	28410.0001	25,29	28827.1001	7		
00824.0002	5,7	28412.0000	33	28837.0000	35		
00970.0000	5,7,17	28413.0000	5	28845.0000	5		
00986.0002	5,7	28413.0001	7	28845.0002	5		
00991.0000	9,13	28413.0002	5	28846.0000	5		
01063.0000	33,35	28413.0003	7	28846.0001	7		
01079.0000	33	28414.0000	5	29064.0001	7		
01085.0002	33,35	28414.0001	7	29791.0000	21,23,27,31		
01100.0000	33	28415.0000	19,25	29810.0000	23,29		
01111.0002	33,35	28417.0000	21,23,27,31	29843.0000	23,29		
01116.0000	33	28446.0000	19,25	32445.0001	33		
01303.0000	33,35	28447.0000	19,25	32591.1001	11,15		
01327.0000	33,35	28450.0000	19,25	32745.1002	11,15,21,27		
01360.0002	19,25	28450.0001	19,25	32759.1002	11,15,21		
01370.0001	17	28451.0000	19,25	32759.1002	23,27,31		
01386.0000	17	28451.0001	19,25	34325.0024	9,13		
01502.0000	33,35	28452.0000	19,25	34325.0025	9,13		
01525.0000	33,35	28452.0001	19,25	34325.1002	11,15		
01533.0004	33,35	28479.0000	33,35	37881.0000	5,7		
01685.0000	33,35	28480.0000	33,35	38129.0003	9,13		
01975.0000	33	28481.0000	33,35	38129.0007	9,13		
02322.0002	5,7	28751.0000	33,35	38129.0009	11,15		
02362.0000	33,35	28752.1003	17	38129.0019	11		
02367.0002	9,13	28752.1004	17	38129.0020	11,15		
03231.0000	33,35	28752.1005	17	38129.1002	11,15		
03356.1000	33,35	28755.1001	17				
03356.1001	33,35	28755.1002	17				
04786.0002	33,35	28755.1004	17				
20630.0016	33,35	28755.1005	17				
21275.0000	11,15	28755.1006	17				
21275.0002	11,15	28756.1000	9,13,19,25				
21275.0003	9,13,19	28756.1001	23,29				
21275.0003	23,25,29	28757.0000	9,13				
21275.0006	9,13	28758.0000	17				
21522.0000	9,13	28759.0000	17				
21634.0003	9,13	28760.0000	9,13				
21993.0002	9,13	28761.0001	9,13				
22150.0001	9,13	28762.0000	17				
22249.0000	9,13	28762.0001	17				
23721.0000	9,15	28766.0000	19,25				
23820.1000	9,13	28767.1000	19,25				
24684.0000	11,15	28769.0001	11,15,19				
25137.0001	5,7	28769.0001	23,25,29				
25139.0000	9,13	28770.0000	19,25				
27035.0001	33,35	28781.1000	19,25				