

BUNN®

FMD-4 *FMD-5*

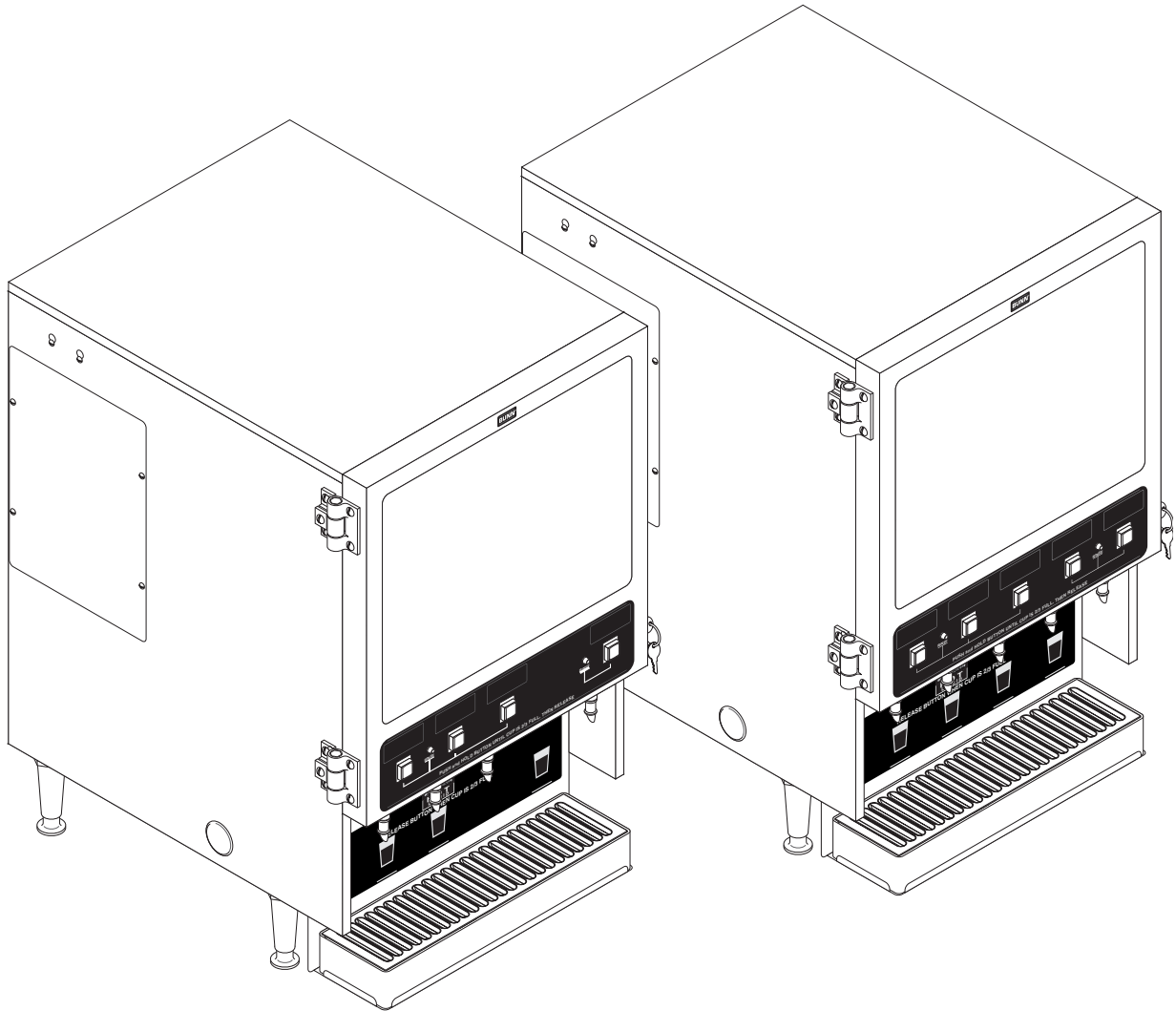

ILLUSTRATED PARTS CATALOG

Designs, materials, weights, specifications, and dimensions for equipment or replacement parts are subject to change without notice.

BUNN-O-MATIC CORPORATION

POST OFFICE BOX 3227

SPRINGFIELD, ILLINOIS 62708-3227

PHONE: (217) 529-6601 FAX: (217) 529-6644



BUNN-O-MATIC COMMERCIAL PRODUCT WARRANTY

Bunn-O-Matic Corp. ("BUNN") warrants equipment manufactured by it as follows:

- 1) Airpots, thermal carafes, decanters, GPR servers, iced tea/coffee dispensers, MCR/MCP/MCA single cup brewers, thermal servers and ThermoFresh® servers (mechanical and digital) 1 year parts and 1 year labor.
- 2) All other equipment - 2 years parts and 1 year labor plus added warranties as specified below:
 - a) Electronic circuit and/or control boards - parts and labor for 3 years.
 - b) Compressors on refrigeration equipment - 5 years parts and 1 year labor.
 - c) Grinding burrs on coffee grinding equipment to grind coffee to meet original factory screen sieve analysis - parts and labor for 4 years or 40,000 pounds of coffee, whichever comes first.

These warranty periods run from the date of installation BUNN warrants that the equipment manufactured by it will be commercially free of defects in material and workmanship existing at the time of manufacture and appearing within the applicable warranty period. This warranty does not apply to any equipment, component or part that was not manufactured by BUNN or that, in BUNN's judgment, has been affected by misuse, neglect, alteration, improper installation or operation, improper maintenance or repair, non periodic cleaning and descaling, equipment failures related to poor water quality, damage or casualty. In addition, the warranty does not apply to replacement of items subject to normal use including but not limited to user replaceable parts such as seals and gaskets. This warranty is conditioned on the Buyer 1) giving BUNN prompt notice of any claim to be made under this warranty by telephone at (217) 529-6601 or by writing to Post Office Box 3227, Springfield, Illinois 62708-3227; 2) if requested by BUNN, shipping the defective equipment prepaid to an authorized BUNN service location; and 3) receiving prior authorization from BUNN that the defective equipment is under warranty.

THE FOREGOING WARRANTY IS EXCLUSIVE AND IS IN LIEU OF ANY OTHER WARRANTY, WRITTEN OR ORAL, EXPRESS OR IMPLIED, INCLUDING, BUT NOT LIMITED TO, ANY IMPLIED WARRANTY OF EITHER MERCHANTABILITY OR FITNESS FOR A PARTICULAR PURPOSE. The agents, dealers or employees of BUNN are not authorized to make modifications to this warranty or to make additional warranties that are binding on BUNN. Accordingly, statements by such individuals, whether oral or written, do not constitute warranties and should not be relied upon.

If BUNN determines in its sole discretion that the equipment does not conform to the warranty, BUNN, at its exclusive option while the equipment is under warranty, shall either 1) provide at no charge replacement parts and/or labor (during the applicable parts and labor warranty periods specified above) to repair the defective components, provided that this repair is done by a BUNN Authorized Service Representative; or 2) shall replace the equipment or refund the purchase price for the equipment.

THE BUYER'S REMEDY AGAINST BUNN FOR THE BREACH OF ANY OBLIGATION ARISING OUT OF THE SALE OF THIS EQUIPMENT, WHETHER DERIVED FROM WARRANTY OR OTHERWISE, SHALL BE LIMITED, AT BUNN'S SOLE OPTION AS SPECIFIED HEREIN, TO REPAIR, REPLACEMENT OR REFUND.

In no event shall BUNN be liable for any other damage or loss, including, but not limited to, lost profits, lost sales, loss of use of equipment, claims of Buyer's customers, cost of capital, cost of down time, cost of substitute equipment, facilities or services, or any other special, incidental or consequential damages.

392, A Partner You Can Count On, Air Infusion, AutoPOD, AXIOM, BrewLOGIC, BrewMETER, Brew Better Not Bitter, BrewWISE, BrewWIZARD, BUNN Espresso, BUNN Family Gourmet, BUNN Gourmet, BUNN Pour-O-Matic, BUNN, BUNN with the stylized red line, BUNNlink, Bunn-O-Matic, Bunn-O-Matic, BUNNserve, BUNNSERVE with the stylized wrench design, Cool Froth, DBC, Dr. Brew stylized Dr. design, Dual, Easy Pour, EasyClear, EasyGard, FlavorGard, Gourmet Ice, Gourmet Juice, High Intensity, iMIX, Infusion Series, Intellisteam, My Café, Phase Brew, PowerLogic, Quality Beverage Equipment Worldwide, Respect Earth, Respect Earth with the stylized leaf and coffee cherry design, Safety-Fresh, savemycoffee.com, Scale-Pro, Silver Series, Single, Smart Funnel, Smart Hopper, SmartWAVE, Soft Heat, SplashGard, The Mark of Quality in Beverage Equipment Worldwide, ThermoFresh, Titan, trifacta, TRIFECTA (stylized logo), Velocity Brew, Air Brew, Beverage Bar Creator, Beverage Profit Calculator, Brew better, not bitter., Build-A-Drink, BUNNSource, Coffee At Its Best, Cyclonic Heating System, Daypart, Digital Brewer Control, Element, Milk Texturing Fusion, Nothing Brews Like a BUNN, Picture Prompted Cleaning, Pouring Profits, Signature Series, Sure Tamp, Tea At Its Best, The Horizontal Red Line, Ultra are either trademarks or registered trademarks of Bunn-O-Matic Corporation. The commercial trifacta® brewer housing configuration is a trademark of Bunn-O-Matic Corporation.

TABLE OF CONTENTS

Auger Drive and Hoppers - FMD-4	12
Auger Drive and Hoppers - FMD-5	14
Covers, Panels and DripTray	4
Dispense Valve and Lines.....	22
Door Assembly	8
Electrical Controls	24
Fill Valve and Drain Line.....	20
Mixing/Whipper Chamber and Drive Motor.....	16
Numerical Index.....	28
Tank, Heater and Overflow Protection	18

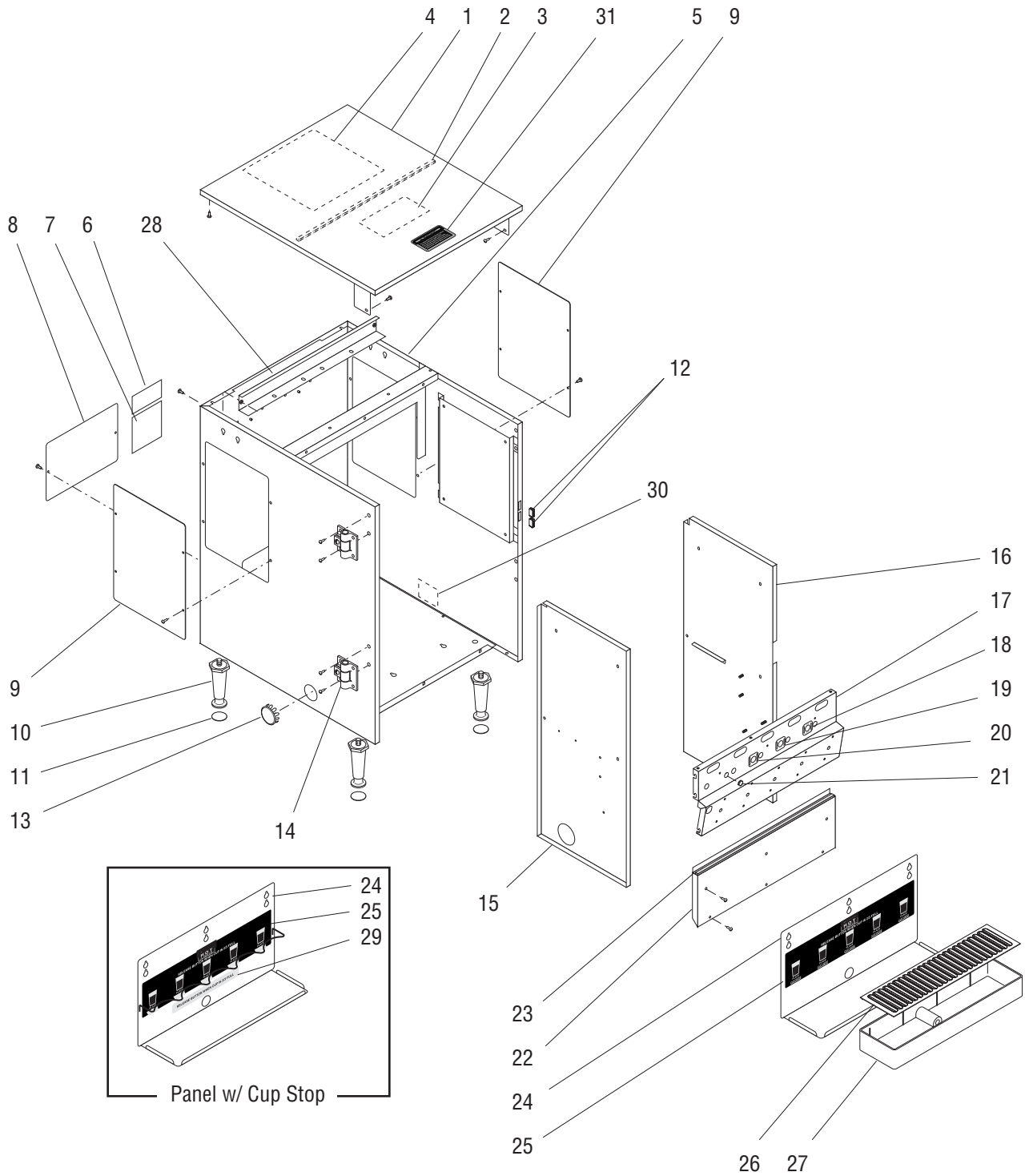

COVERS, PANELS & DRIP TRAY

ITEM	PART NO.	QTY.	DESCRIPTION	
1	34608.1000	1	Cover w/Decals, FMD-4 (120V)	} Includes items 3 and 4 Also order item 2
	34608.1001	1	Cover w/Decals, FMD-4 (120/208 or 120/240V)	
	34608.1002	1	Cover w/Decals, FMD-5 (120V)	
	34608.1003	1	Cover w/Decals, FMD-5 (120/208 or 120/240V)	
	01311.0001	2	Screw, Locking #8-32 x .25"	
	01315.0000	2	Screw #8-32 x .38"	
2	-----	1	Seal, Adhesive Backed 17.25" (Order item 32)	
3	28368.0000	1	Decal, Thermostat Adjustment (Invensys Thermostats)	
	28368.0004	1	Decal, Thermostat Adjustment (Cootherm Thermostats)	
4	34725.0000	1	Schematic, FMD-4 (120V)	
	34725.0001	1	Schematic, FMD-4 (120/208 or 120/240V)	
	34820.0000	1	Schematic, FMD-5 (120V)	
	34820.0001	1	Schematic, FMD-5 (120/208 or 120/240V)	
5	34627.1000	1	Housing w/Decals, Main (Includes items 6 and 7)	
6	00656.0001	1	Decal, Comply To Plumbing Code	
7	00831.0000	1	Decal, Warning - Electrical	
8	28206.0000	1	Cover, Rear Access	
	01311.0003	2	Screw BLK #8-32 x .25"	
9	34649.0001	2	Panel, Side Access	
	01311.0003	8	Screw BLK #8-32 x .25"	
10	26528.0000	4	Leg, 4" Adjustable (Refer to item 33)	
11	03996.0000	4	Pad, Rubber ((Refer to item 33)	
12	21436.0000	2	Catch, Magnetic	
13	23164.0002	1	Plug, Hole 1.25" Dia., Blk (Early Models)	
14	32812.0000	2	Hinge	
	33045.0000	8	Screw .25-20 x .75" Blk	
15	34972.0000*	1	Panel, Inner Left	
	01311.0001	4	Screw, Locking #8-32 x .25"	
16	34971.0000*	1	Panel, Inner Right	
	01311.0001	4	Screw, Locking #8-32 x .25"	
17	34671.0000	1	Panel, Whipper (FMD-4)	
	34611.0000	1	Panel, Whipper (FMD-5)	
	00991.0000	6	Nut, Elastic Lock #8-32	
18	26524.0000	1	Decal, Tank Heater Switch	
19	26523.0000	1	Decal, Rinse/Run Switch	
20	28872.0000	1	Decal, Increase/Decrease Switch	
21	00619.0010	1	Plug, Hole .438" Nkl-Pltd.	

(Continued)

* Indicates the part number listed is for reference only. See DESCRIPTION for possible service replacement.

(Continued)

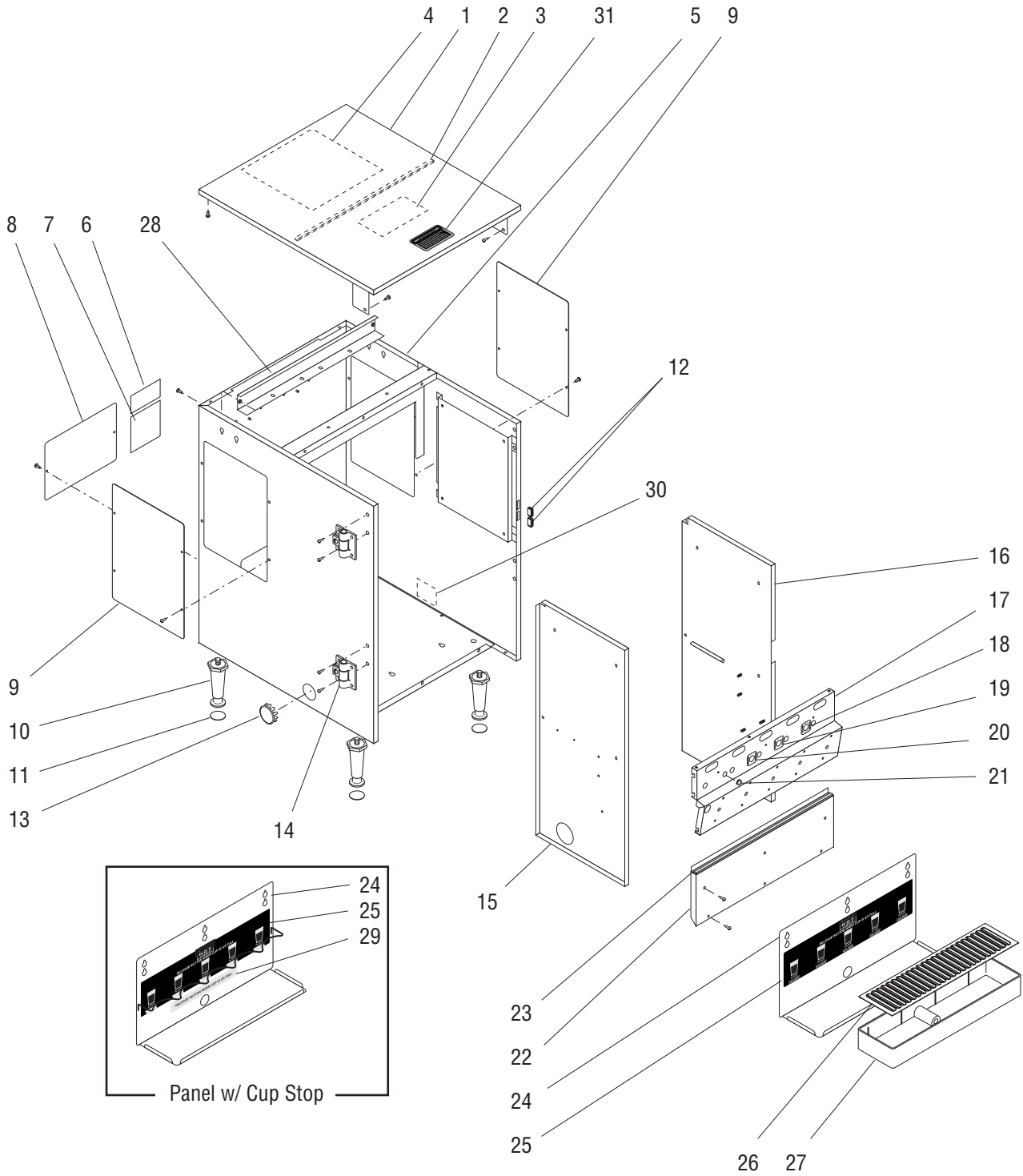

COVERS, PANELS & DRIP TRAY

ITEM	PART NO.	QTY.	DESCRIPTION
22	34610.0000	1	Panel, Lower Access
	01311.0000	3	Screw #8-32 x .25"
	01311.0001	3	Screw, Locking #8-32 x .25"
23	-----	1	Seal, Adhesive Backed 16.50" (Order item 32)
24	34621.1000	1	Panel w/Decals FMD-4
	34621.1001	1	Panel w/Decals FMD-5
	38026.0000	1	Panel w/Cup Stop FMD-5
			Includes item 25
25	28328.0008	1	Decal, Cup Placement (FMD-4)
	28328.0009	1	Decal, Cup Placement (FMD-5)
26	34717.0000	1	Cover, Drip Tray
27	34716.0000	1	Drip Tray
28	36194.0000	1	Bracket (Late models)
	02308.0000	2	Screw, Pan Head #8-32 x .38"
29	38019.0000	1	Decal, Release Button
30	39803.0000	1	Decal, Main ON/OFF Arrow (Models with Master ON/OFF Switch)
31	37881.0000	1	Decal, No Serviceable Parts
32	28366.1001	-	Seal, Adhesive Backed 36.0" (Cut to required length)
33	13255.0003	-	Kit, Leg 4.0" Adjustable (Includes 4 each of items 10 and 11)

* Indicates the part number listed is for reference only. See DESCRIPTION for possible service replacement.

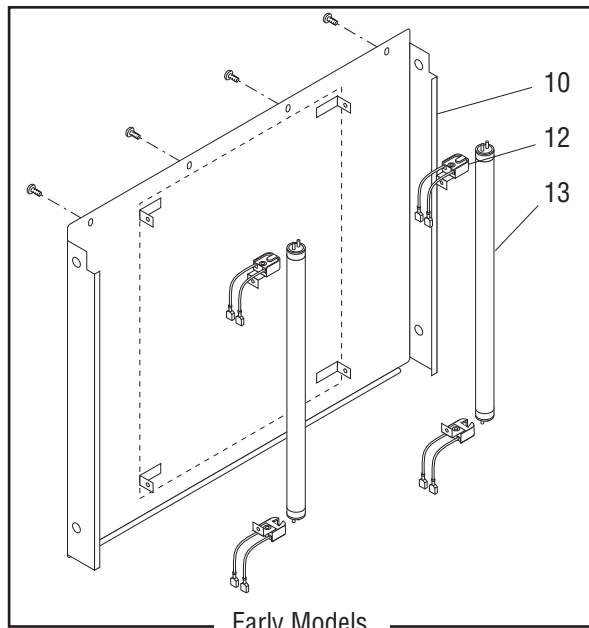
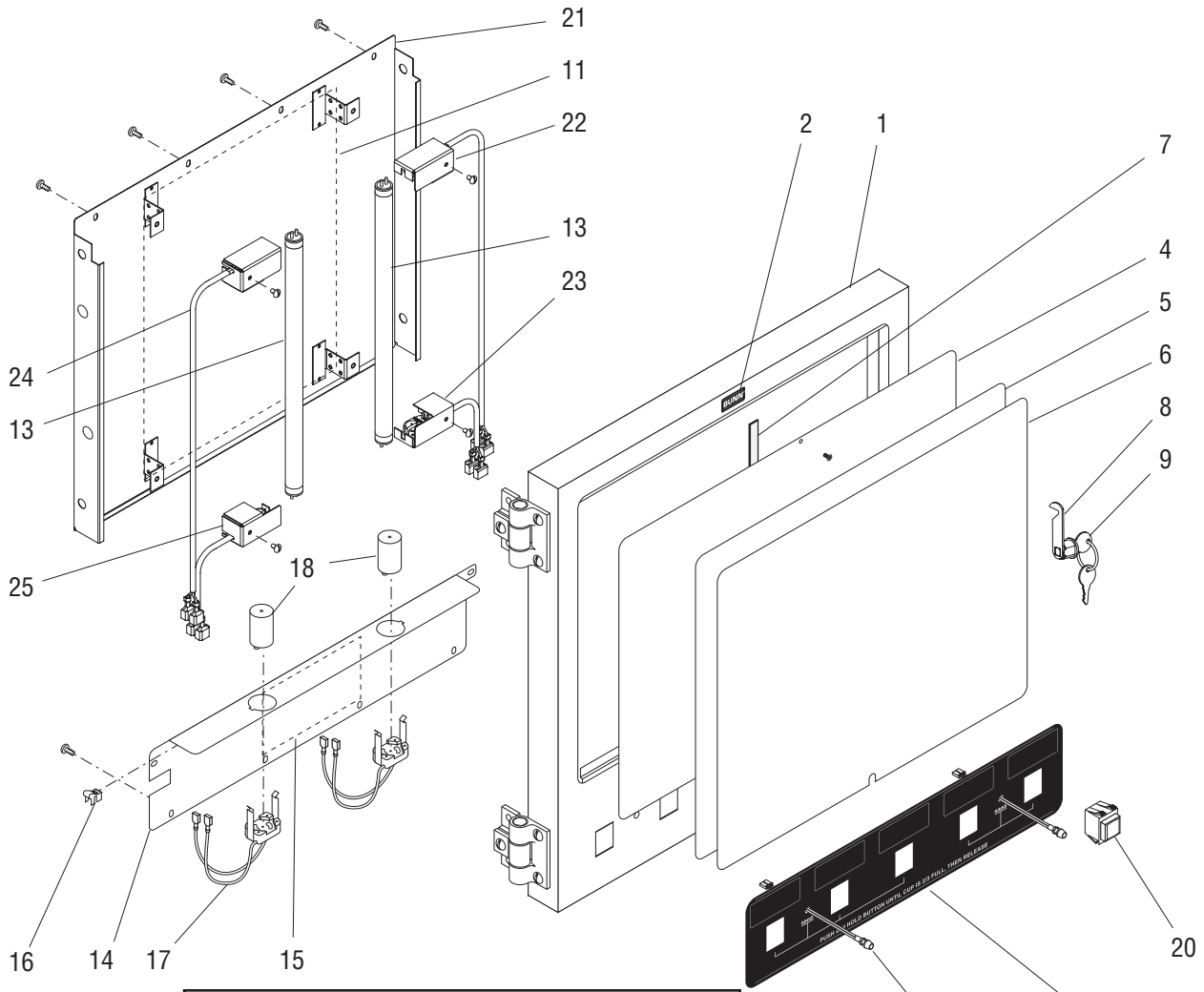

Early Models

DOOR ASSEMBLY

ITEM	PART NO.	QTY.	DESCRIPTION
1	34489.1000	1	Door Assy, FMD-4 (Includes items 2,3 and 7)
	34489.1001	1	Door Assy, FMD-5 (Includes items 2,3 and 7)
2	23279.0000	1	Decal, BUNN
3	28964.0004	1	Decal, Dispense Switch (FMD-4)
	28964.0003	1	Decal, Dispense Switch (FMD-5)
4	34720.0001	1	Lens, Merchandiser - Fixed
	35103.0000	2	Screw, Flat Head Phillips #4-40
5	34721.0000	1	Display, Graphics
6	34719.0001	1	Lens, Merchandiser - Removable
7	27298.0500	1	Striker Assy.
8	34722.0000	1	Lock Assy. (Includes item 9)
9	28095.0000	1	Key Set (Includes two keys)
10	35076.0000	1	Panel, Upper Door
	01311.0000	4	Screw #8-32 x .25"
11	34827.0000	1	Decal, Cleaning Instructions (FMD-4)
	34718.0000	1	Decal, Cleaning Instructions (FMD-5)
12	28322.0000	4	Lamp Holder
	02328.0002	4	Screw, Pan Head #6-32 x .188"
13	26239.0000	2	Lamp, Flourescent
14	34492.0000	1	Panel, Lower Door 120V
	40781.0000	1	Panel, Lower Door 230V
	01311.0000	6	Screw #8-32 x .25"
15	29308.0000	1	Decal, Hopper Installation
16	28335.0000	1	Clip, Ground
17	28325.0000	2	Socket, Starter 120V
	40782.0000	2	Socket, Starter 230V
18	27619.0000	2	Starter, Lamp
19	12517.0001	2	Lamp Assy L.E.D.
20	28296.1000	5	Switch, Dispense (One less used on FMD-4)
21	35076.0001*	1	Panel, Upper Door (Late Models)
	01311.0000	4	Screw #8-32 x .25"
22	27543.1003	1	Lampholder Assy, Upper Right (Late Models)
	01308.0000	1	Screw, Truss Head #6-32 x .25"
23	27543.1004	1	Lampholder Assy, Lower Right (Late Models)
	01308.0000	1	Screw, Truss Head #6-32 x .25"
24	27543.1005	1	Lampholder Assy, Upper Left (Late Models)
	01308.0000	1	Screw, Truss Head #6-32 x .25"

(Continued)

* Indicates the part number listed is for reference only. See DESCRIPTION for possible service replacement.

(Continued)

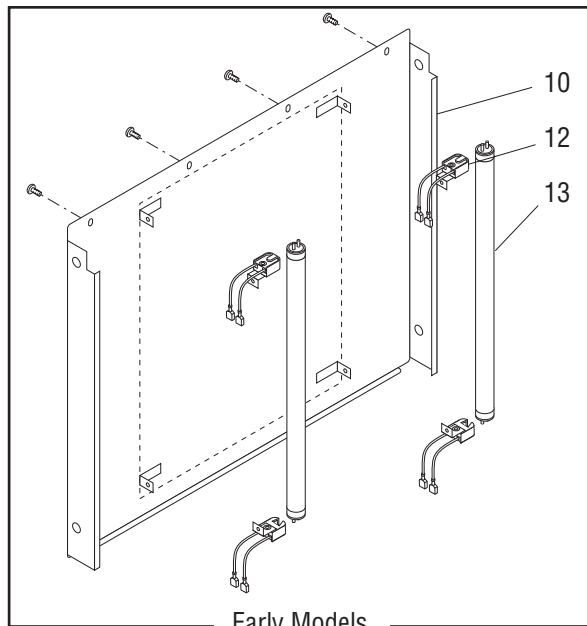
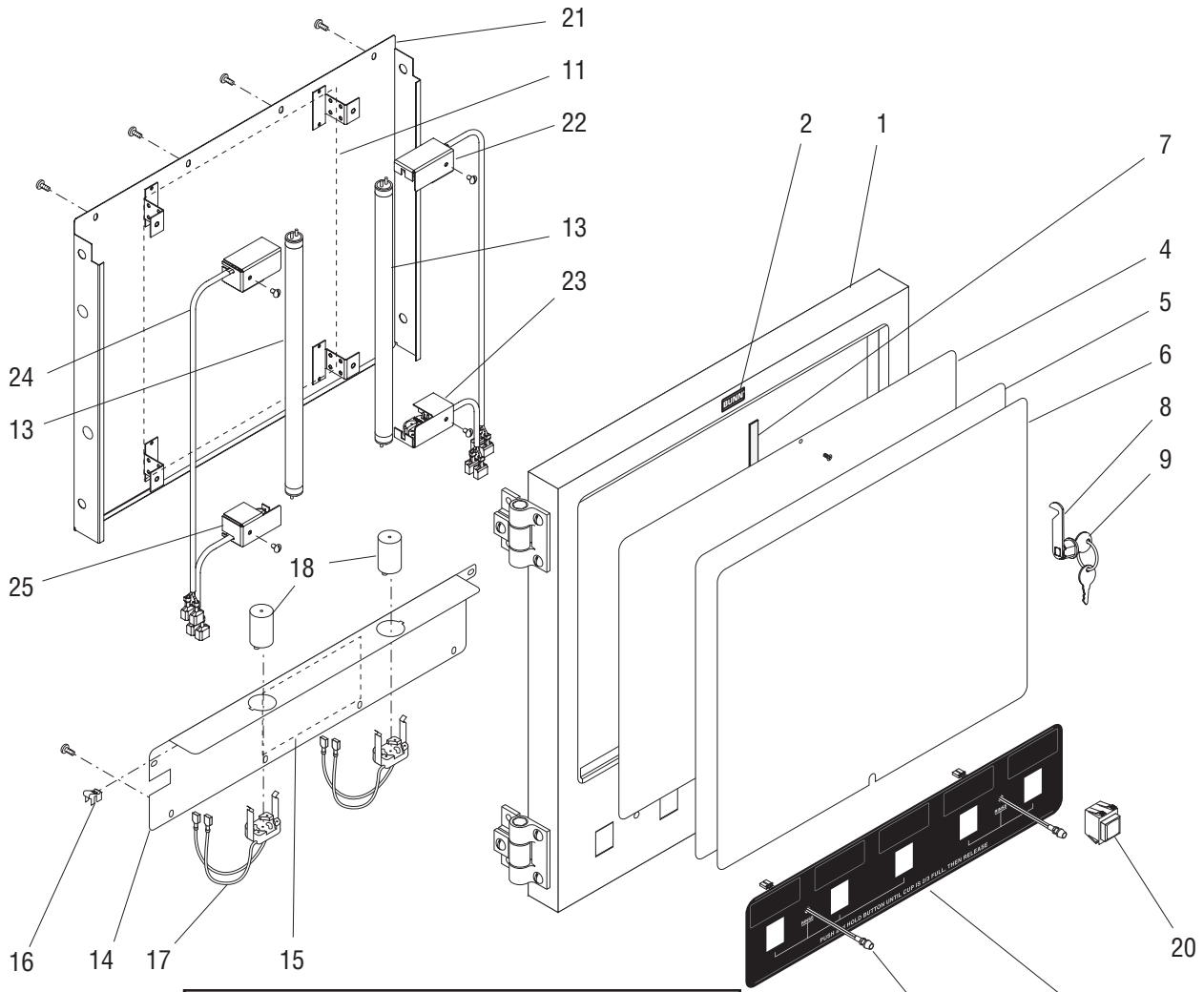

DOOR ASSEMBLY

ITEM	PART NO.	QTY.	DESCRIPTION
25	27543.1006	1	Lampholder Assy, Lower Left (Late Models)
	01308.0000	1	Screw, Truss Head #6-32 x .25"
The following items are not illustrated			
26	28336.0000	1	Wiring Harness, Door
27	35099.0000	1	Wiring Harness, Door Interconnect (FMD-4)
	34985.0000	1	Wiring Harness, Door Interconnect (FMD-5)
28	26537.0000	1	Decal, Flavors (Almond Amaretto, Cappuccino, French Vanilla, Hazelnut, Hot Chocolate and Raspberry Mocha)
	26537.0001	1	Decal, Flavors (Swiss Mocha, Mocha, Raspberry Vanilla, Irish Creme, Coffee and Original)
	26537.0003	1	Decal, Flavors (White Chocolate, Cinnamon Vanilla Nut, Decaf, Regular, French Vanilla and Hot Chocolate)

* Indicates the part number listed is for reference only. See DESCRIPTION for possible service replacement.

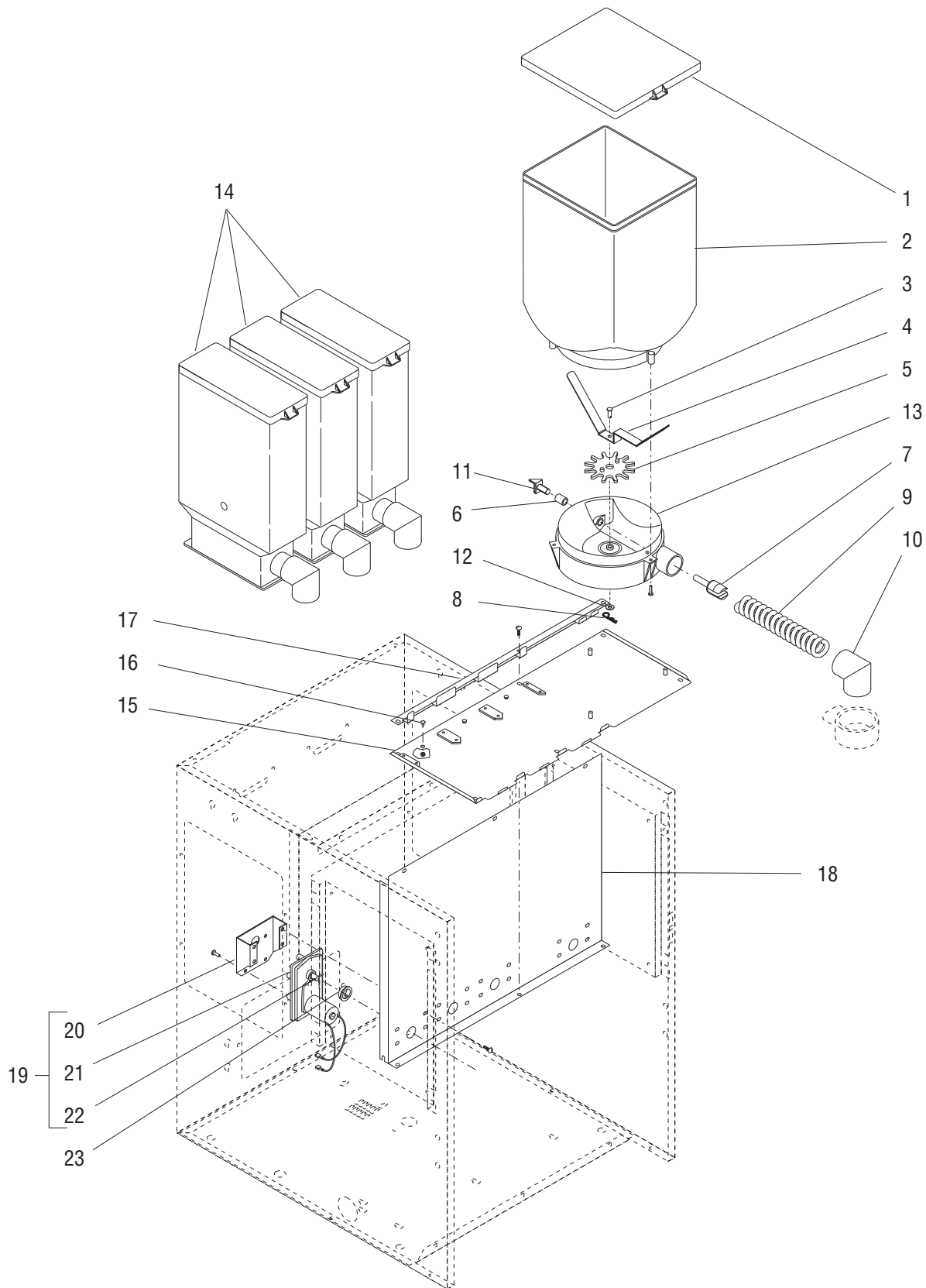

AUGER DRIVE & HOPPERS - FMD-4

ITEM	PART NO.	QTY.	DESCRIPTION
-	29014.1000	1	Hopper & Auger Drive Assy (Includes items 1 thru 13)
1	28679.0000	1	Lid, Hopper
2	28698.0000	1	Hopper
	20377.0001	3	Screw, Pan Head #4-20 x .50"
3	21357.0000	1	Shaft, Wiper
4	21747.0001	1	Blade, Wiper
5	21746.0000	1	Gear, Wiper Drive
6	25892.0000	1	Spacer, .312" I.D. x .437" O.D. x .56" LG
7	26940.0003	1	Shaft, Auger Drive
8	21358.0000	1	Clip, Retainer
9	21355.0000	1	Auger, Wire
10	25903.0000	1	Elbow, Ejector
11	32383.0000	1	Bracket, Auger Drive
12	01522.0000	1	Washer, .203" I.D. x .50" O.D.
13	21465.0001	1	Base, Hopper
14	28424.1000	3	Hopper & Auger Drive Assy (See page 13 for components)
15	34672.0000	1	Panel, Hopper Support
	01311.0000	6	Screw #8-32 x .25"
16	20960.0000	3	Shoulder Screw
	00991.0002	3	Nut, Elastic Lock #6-32
17	29713.0001	1	Bracket, Hopper Locator
18	34669.0000	1	Panel, Hopper Motor
	01311.0001	5	Screw, Locking #8-32 x .25"
19	29642.1001	4	Gearmotor Assembly (Includes items 20 thru 22)
	01311.0001	16	Screw, Locking #8-32 x .25"
20	25794.0001	4	Bracket, Motor Mounting
21	-----	4	Gearmotor w/Pin, Auger (Not available. Order item 19)
	01311.0000	16	Screw #8-32 x .25"
	01511.0000	4	Lockwasher, External Tooth #8
22	26247.0000	4	Pin, Spring .094" Dia. x 1.0"
	26247.1000	-	Kit, Spring Pin (Includes 6 Pins)
23	26401.0000	4	Dust Seal

* Indicates the part number listed is for reference only. See DESCRIPTION for possible service replacement.

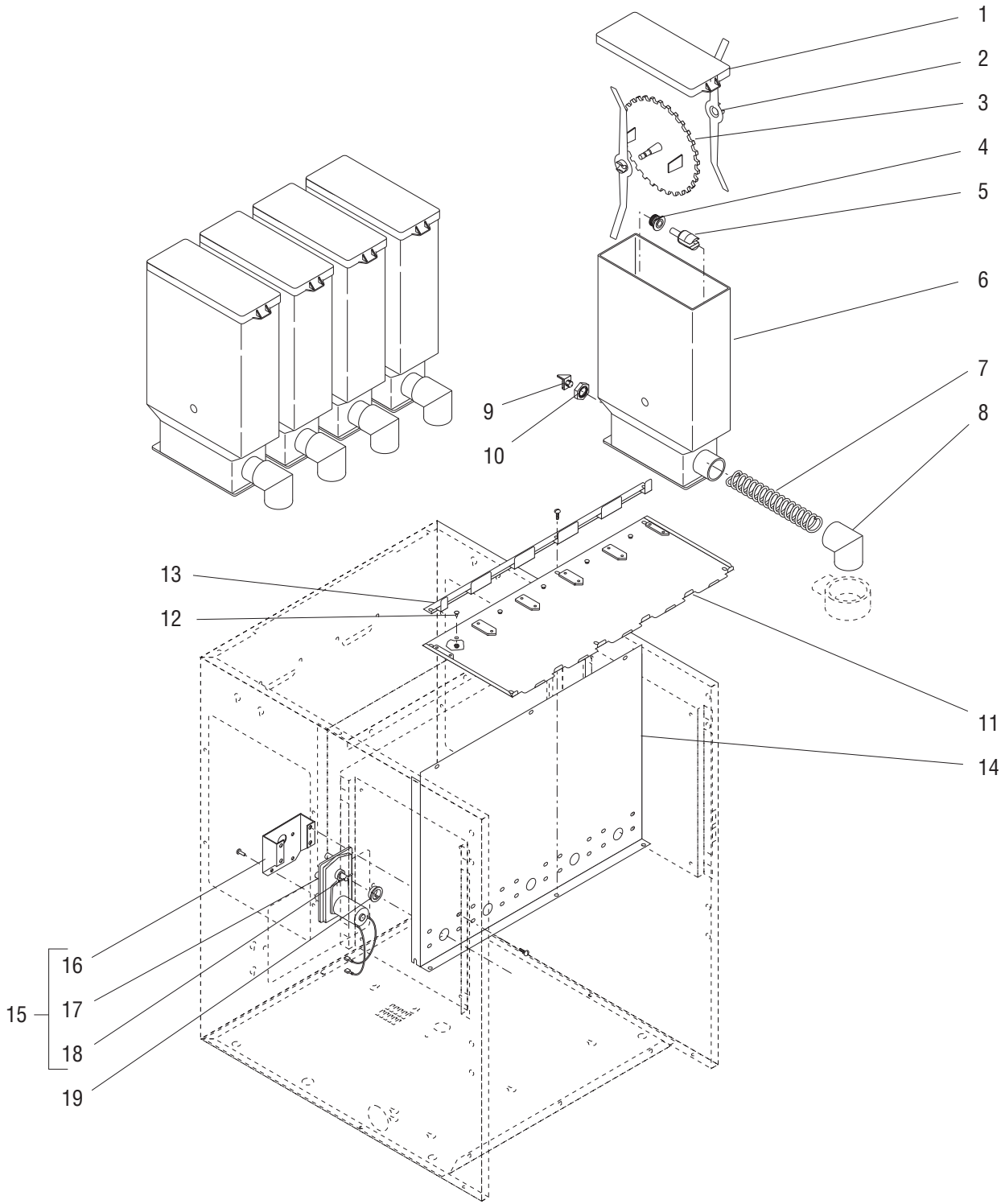

AUGER DRIVE & HOPPERS - FMD-5

ITEM	PART NO.	QTY.	DESCRIPTION
-	28424.1000	5	Hopper Assy (Each includes items 1 thru 10)
1	28061.0000	1	Lid, Hopper
2	32337.0000	2	Mixing Blade
3	32386.0000	1	Disk, Agitator (22 Tooth)
4	28067.0000	1	Bushing, Auger Drive Shaft
5	26940.0002	1	Shaft, Auger Drive
6	28425.0000	1	Hopper
7	26112.0001	1	Auger, Wire
8	25903.0000	1	Elbow, Ejector
9	32383.0000	1	Bracket, Auger Drive
10	25743.0000	1	Locknut
11	34607.0000	1	Panel, Hopper Support
	01311.0000	6	Screw #8-32 x .25"
12	20960.0000	5	Shoulder Screw
	00991.0002	5	Nut, Elastic Lock #6-32
13	34615.0000	1	Bracket, Hopper Locator
14	34614.0000	1	Panel, Hopper Motor
	01311.0001	5	Screw, Locking #8-32 x .25"
15	29642.1001	5	Gearmotor Assembly (Includes items 16 thru 18)
	01311.0001	20	Screw, Locking #8-32 x .25"
16	25794.0001	5	Bracket, Motor Mounting
17	-----	5	Gearmotor w/Pin, Auger (Not available. Order item 15)
	01311.0000	20	Screw #8-32 x .25"
	01511.0000	5	Lockwasher, External Tooth #8
18	26247.0000	5	Pin, Spring .094" Dia. x 1.0"
	26247.1000	-	Kit, Spring Pin (Includes 6 Pins)
19	26401.0000	5	Dust Seal

* Indicates the part number listed is for reference only. See DESCRIPTION for possible service replacement.

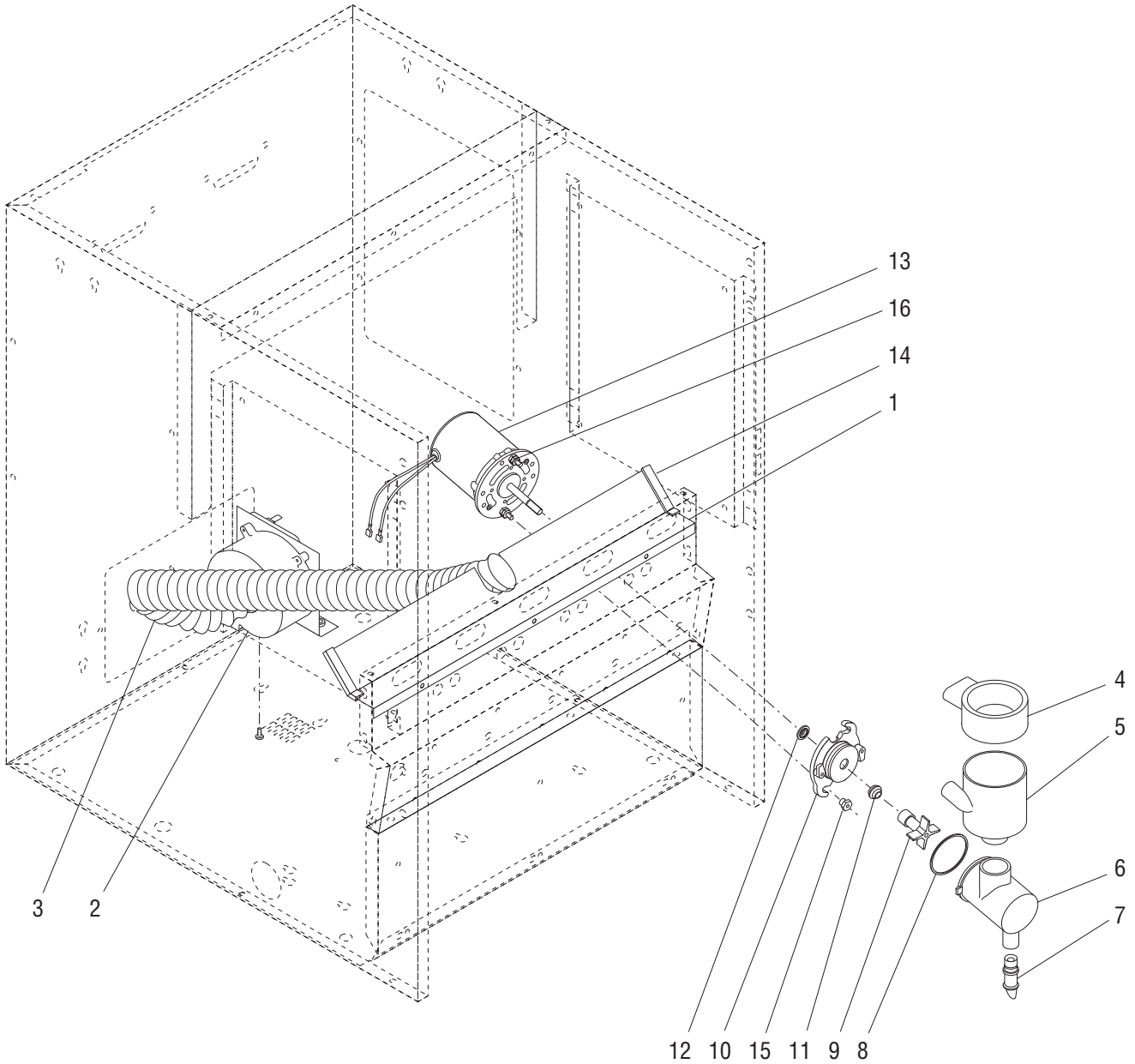

MIXING/WHIPPER CHAMBER & DRIVE MOTOR

ITEM	PART NO.	QTY.	DESCRIPTION
			*FMD-4
			**FMD-5
		* **	
1	35079.1000	1 1	Baffle Assembly, Fan (Includes item 14)
	02336.0000	3 3	Screw, Truss Head #4-40 x .25"
2	28295.0000	1 1	Fan & Bracket Assembly (120V)
	28295.0001	1 1	Fan & Bracket Assembly (230V)
	01311.0001	2 2	Screw, Truss Head #8-32 x .25" Locking
3	28297.0000	1 1	Hose, Vacuum
4	25732.0000	4 5	Steam Collector
5	25733.0000	4 5	Mixing Chamber
6	25734.1000	4 5	Whipper Chamber
7	25736.0000	4 5	Dispense Tip - Drink .34" ID
	28864.0004	4 5	Dispense Tip - Soup .40" ID
8	24733.0010	4 5	O-Ring
9	25902.0000	4 5	Frother
10	28866.0000	4 5	Receptacle, Whipper Chamber
11	26356.0000	4 5	Seal, Shaft
	26356.1000	- -	Kit, Shaft Seal (Includes 6 Seals)
12	28867.0000	4 5	Slinger
13	28428.1000	4 5	Motor, Whipper 120V (Includes item 16)
	28428.1002	4 5	Motor, Whipper 230V (Includes item 16)
14	02434.0009*	2 2	Gasket, Silicone 2.25" LG (Order item 17)
15	28865.0000	8 10	Nut
16	32306.0000	8 10	Spacer
17	02434.1000	- -	Gasket, Silicone 18" LG
18	32906.0000	- -	Kit, Preventive Maintenance (Includes one of items 4 - 11 and 25903.0000 Elbow)

* Indicates the part number listed is for reference only. See DESCRIPTION for possible service replacement.

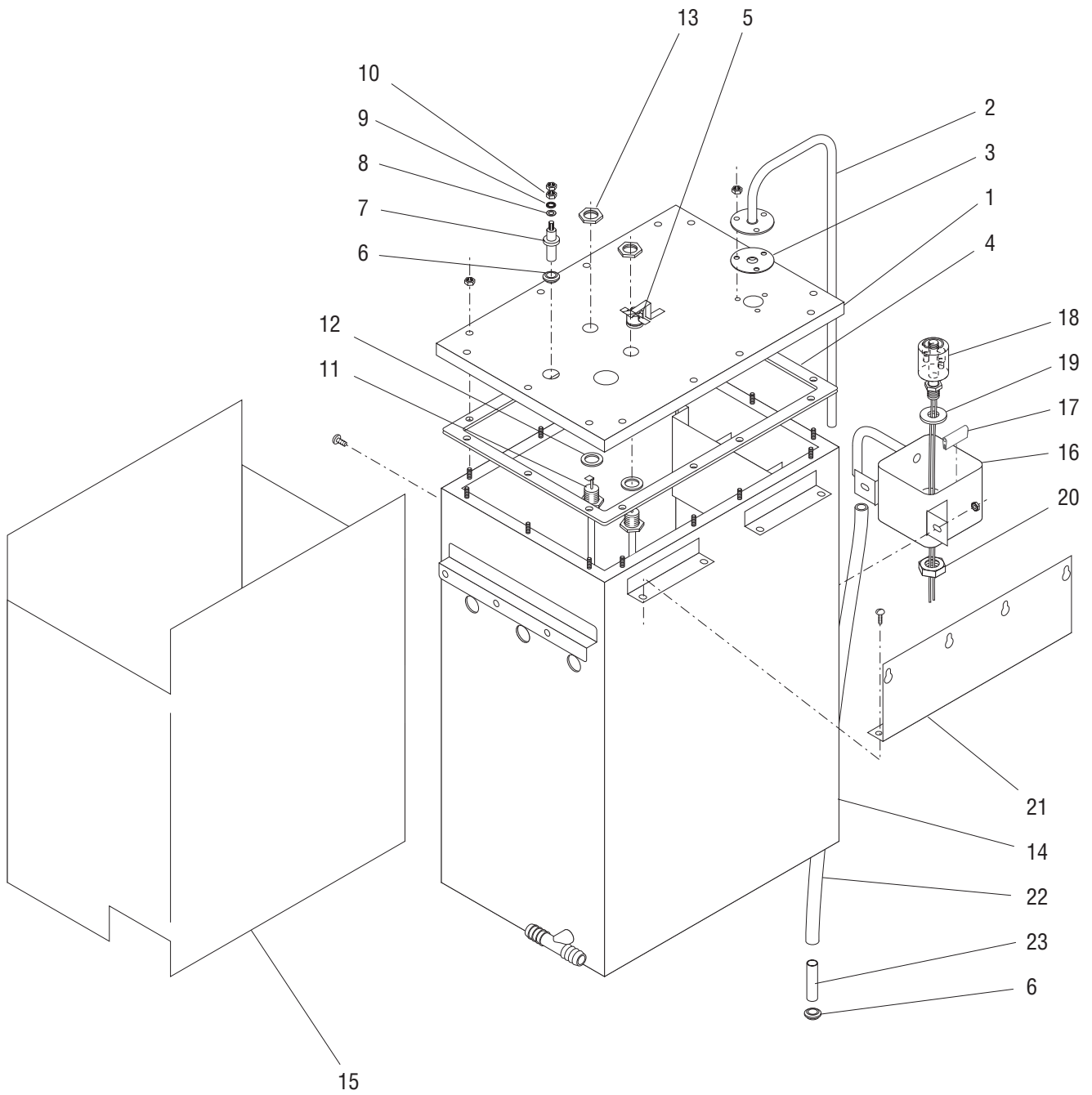

TANK, HEATER & OVERFLOW PROTECTION

ITEM	PART NO.	QTY.	DESCRIPTION
1	34584.0000	1	Lid, Tank
	00908.0000	14	Nut, Hex #8-32
2	35011.0000*	1	Tube, Overflow
	00908.0000	3	Nut, Hex #8-32
3	05515.0000	1	Gasket
4	34866.0000	1	Gasket, Tank Lid
5	29329.1000	1	Limit Thermostat
6	02536.0000	2	Grommet
7	07412.1002	1	Level Probe Kit (Includes items 8, 9 and 10)
8	20203.0100	1	Lockwasher, Internal Tooth #8
9	01501.0000	1	Washer, Flat
10	00908.0000	2	Nut, Hex #8-32
11	20201.4151	1	Tank Heater, 1700W, 120V (Includes item 12)
	20201.0750	1	Tank Heater, 3500W, 240V (Includes item 12)
12	00943.0000	2	Gasket, Tank Heater
13	00942.0000	2	Nut, Hex .50"-20
14	37983.1000	1	Tank (Includes Grommets)(With copper overflow cup)
	37983.1001	1	Tank (Includes Grommets)(With aluminum overflow cup)
	02308.0000	8	Screw, Pan Head #8-32 x .38"
15	35012.0000*	1	Insulation, Tank
16	22728.0000	1	Cup, Overflow (Copper)
	00970.0000	2	Nut, Keps #8-32
	41259.0001	1	Overflow Cup (Aluminum)
	41266.0000	1	Film
	41280.0000	1	Elbow
	04797.0000	1	Washer
17	02434.0010*	1	Gasket, U-channel 2.0" (Order item 24)
18	03803.0000	1	Switch, Liquid Level
19	03633.0000	1	Gasket, Silicone
20	00946.0000	1	Nut, Hex Brass .50"-20
21	35020.0000	1	Bracket, Tank Support
	02308.0000	4	Screw, Pan Head #8-32 x .38"
22	28526.0008*	1	Tube, Silicone .312" I.D. x .438" O.D. x 12.0" (Order item 25)
23	21801.0015	1	Tube .375" O.D. x 1.50"
24	02434.1000	-	Gasket, U-channel 18.0" (Cut to Required Length)
25	28526.1001	-	Tube, Silicone .312" I.D. x .438"O.D. x 36"
	28526.1002	-	Tube, Silicone .312" I.D. x .438"O.D. x 60"
	28526.1003	-	Tube, Silicone .312" I.D. x .438"O.D. x 120"

} Not Illustrated

* Indicates the part number listed is for reference only. See DESCRIPTION for possible service replacement.

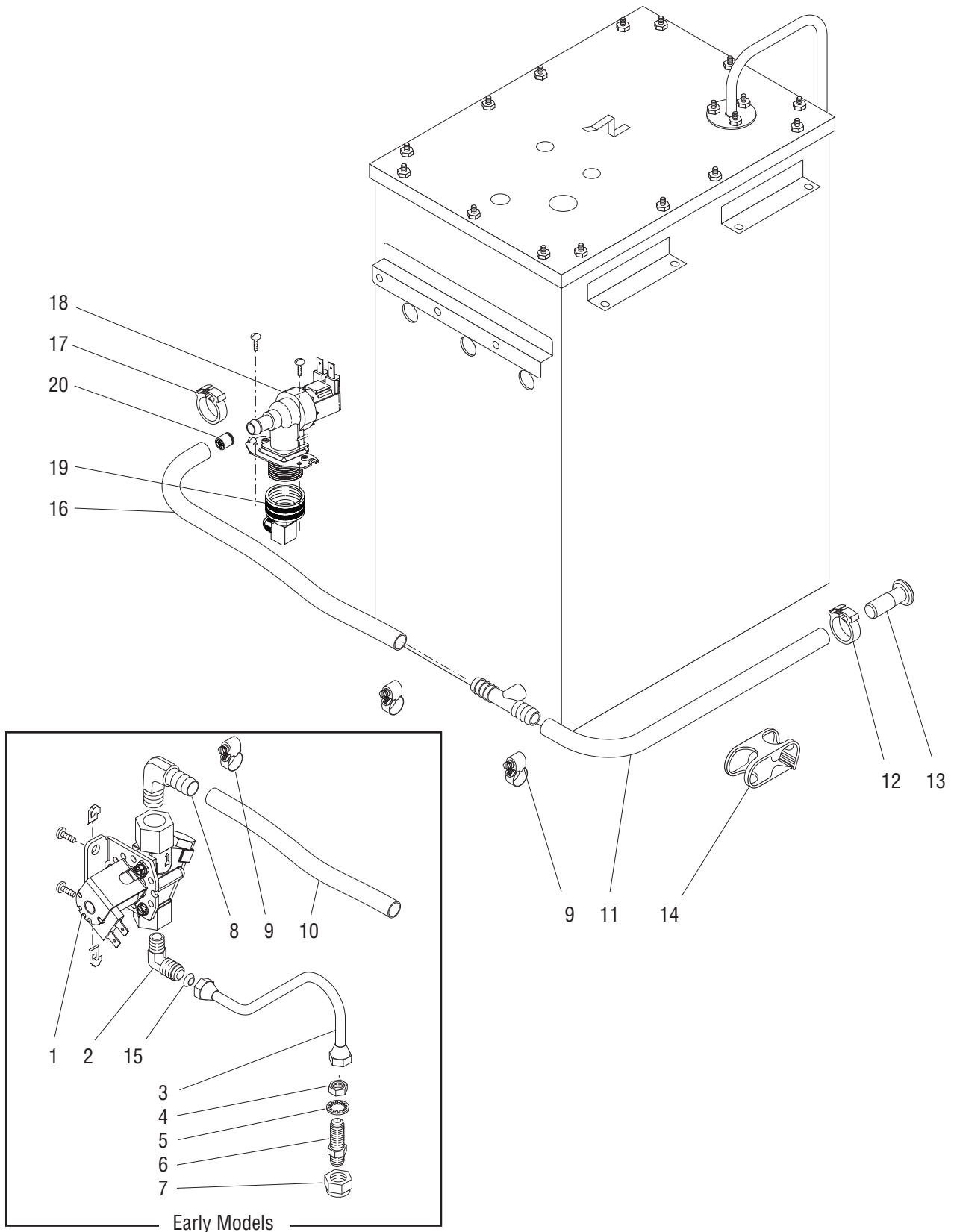

FILL VALVE & DRAIN LINE

ITEM	PART NO.	QTY.	DESCRIPTION
1	35094.1000	1	Valve Assy, Inlet 120V
	00938.0000	2	Fastener, U-Type #8
	02322.0002	2	Screw, Truss Head #8-32 x .375" Blk
2	34768.0000	1	Fitting, 90° Elbow .375" MPT x .375" flare
3	34993.0000	1	Tube
4	12757.0000	1	Nut, Hex .625"-18 Brass
5	01514.0000	1	Lockwasher, Internal Tooth .625"
6	12756.0000	1	Fitting, Bulkhead Male .38" flare
7	00976.0000	1	Cap Nut .375" flare, Brass
8	33606.0001	1	Elbow .375" NPT x .50" Barb
9	35134.0000	3	Clamp, Hose, Wormdrive .312" to .50"
10	20976.0005*	1	Tube, Silicone .38" I.D. x 7.5" (Order item 21)
11	20976.0069*	1	Tube, Silicone .38" I.D. x 24.0" (Order item 21)
12	12422.0001	1	Clamp, Hose .59/.66" I.D.
13	34392.0000	1	Plug
14	11630.0001	1	Clamp, Tubing Shut Off
15	32359.0000	1	Gasket, Copper
16	20976.0043*	1	Tube, Silicone .38" I.D. x 10.75" (Order item 21)
17	12422.0001	1	Clamp, Hose .59/.66" I.D.
18	36233.1000	1	Valve, Water Inlet 120V
	36233.0001	1	Valve, Water Inlet 230V
	32283.0000	2	Screw, Pan Head M4 x 6MM
19	37297.0006	1	Elbow .25" Flare x .75" FTHRD
20	36378.0001	1	Check Valve 2.5psi (Late Models)
21	20976.1000	-	Tube, Silicone .38" I.D. x 12.0" (Cut to Required Length)
	20976.1001	-	Tube, Silicone .38" I.D. x 30.0" (Cut to Required Length)
22	43644.0000	-	Kit, Valve Rebuild (Not Illustrated)

* Indicates the part number listed is for reference only. See DESCRIPTION for possible service replacement.

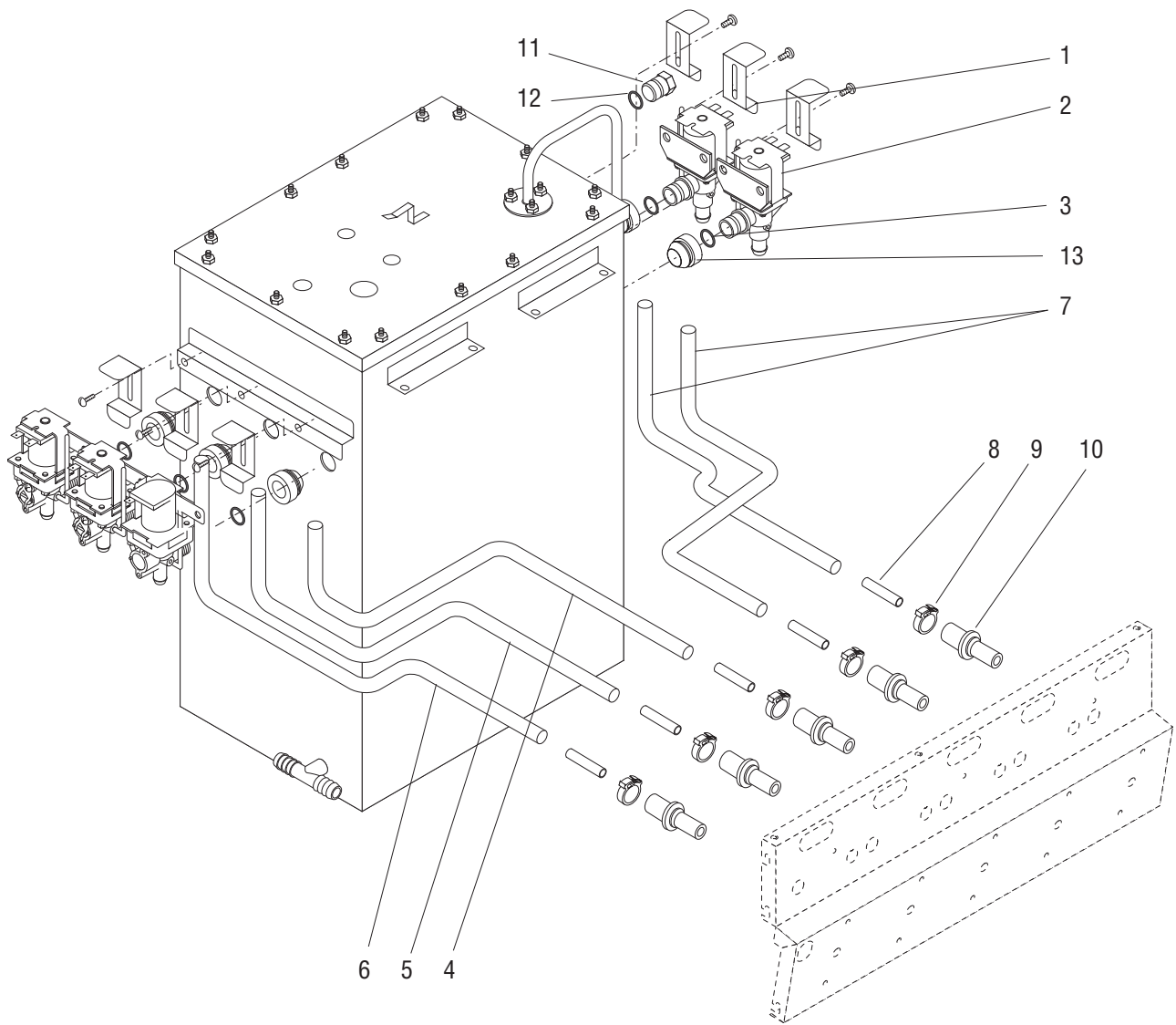

DISPENSE VALVES & LINES

ITEM	PART NO.	QTY.	DESCRIPTION
			*FMD-4
			**FMD-5
		* **	
1	29576.0000	5 5	Bracket, Valve Mounting
	00970.0000	5 5	Nut, Keps #8-32 (Early Models)
	01326.0000	5 5	Screw, Truss Head #10-32 x .25" (Late Models)
2	39285.1001	4 5	Valve, Dispense 120V (Includes item 1)
	39285.1002	4 5	Valve, Dispense 230V (Includes item 1)
3	24733.0011	4 5	O-ring
4	28526.0012*	1 1	Tube, Silicone .312" I.D. x .438" O.D. x 14.6" (Order item 14)
5	28526.0002*	1 1	Tube, Silicone .312" I.D. x .438" O.D. x 16.0" (Order item 14)
6	28526.0016*	1 1	Tube, Silicone .312" I.D. x .438" O.D. x 18.0" (Order item 14)
7	28526.0023*	1 2	Tube, Silicone .312" I.D. x .438" O.D. x 17.0" (Order item 14)
8	21801.0015	4 5	Tube .375" O.D. x 1.50"
9	12422.0001	4 5	Clamp, Hose .59/.66" I.D.
10	25803.0000	4 5	Water Inlet Mixing Chamber
11	26369.0000	1 -	Plug
12	24733.0011	1 -	O-ring
13	37970.0000	4 5	Grommet (Late Models)
14	28526.1001	- -	Tube, Silicone .312" I.D. x .438" O.D. x 36"
	28526.1002	- -	Tube, Silicone .312" I.D. x .438" O.D. x 60"
	28526.1003	- -	Tube, Silicone .312" I.D. x .438" O.D. x 120"
			} Not Illustrated
15	45964.1000	4 5	Repair Kit, Dispense Valve

* Indicates the part number listed is for reference only. See DESCRIPTION for possible service replacement.

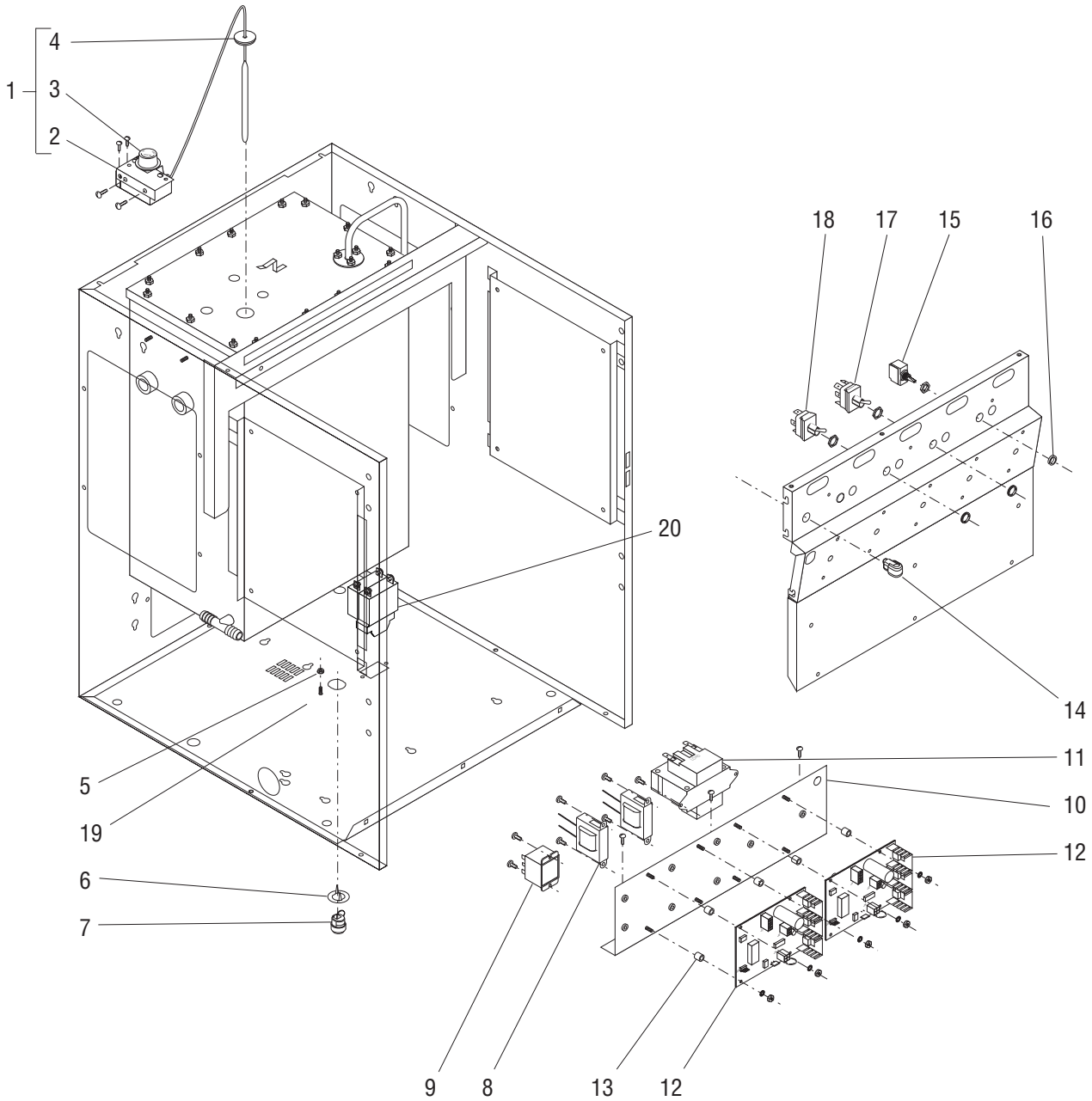

ELECTRICAL CONTROLS

ITEM	PART NO.	QTY.	DESCRIPTION
1	40791.1006	1	Thermostat Assembly
	01311.0003	2	Screw, Truss Head #8-32 x .25" Blk (Mounting)
	20762.0000	2	Screw, Binding Head #8-32 x .25" (Terminal)
2	28224.0000	1	Bracket
	02301.0001	2	Screw, Pan Head #6-32 x .312"
3	00720.0000	1	Knob
4	07073.1000	1	Grommet
5	00970.0000	1	Nut, Keps #8-32 - Power Cord Ground
6	00715.0000	1	Adapter Washer, Strain Relief
7	00713.0000	1	Bushing, Strain Relief
8	28327.0000	2	Ballast 120V
	39642.0000	2	Ballast 230V
	01311.0001	4	Screw, Locking #8-32 x .25"
9	35207.0000	1	Relay 120V
	35207.0002	1	Relay 230V
	02308.0000	2	Screw #8-32 x .25" (Early Models)
	00973.0000	2	Nut, Keps #6-32 (Late Models)
10	34625.0000	1	Bracket 120V
	34625.0002*	1	Bracket 230V
	01311.0000	3	Screw #8-32 x .25"
11	32824.0001	1	Transformer 120V
	39417.0001	1	Transformer 230V
	01311.0001	2	Screw, Locking #8-32 x .25"
12	42996.1000	2	Control Board
	01510.0000	8	Lockwasher, External Tooth #6
	00973.0000	8	Nut, Keps #6-32
13	00450.0000	8	Spacer
14	01666.0001	1	Bushing, Strain Relief
15	23522.1000	1	Switch, Tank Heater
16	23697.0000	1	Nut, Plastic Face .469"-32
17	28857.1000	1	Switch, Rinse/Run (Includes nuts)
18	28856.1000	1	Switch, Increase/Decrease (Includes nuts)
19	00824.0002	1	Decal, Grounding 230V
20	38894.0001	1	Switch, Master ON/OFF
	01308.0002	2	Screw, Truss Hd., Locking #6-32 x .25" (mounting)
	01327.0000	4	Screw, Pan Hd. #10-32 x .38"  terminals
	01512.0000	4	Lockwasher #10

(Continued)

* Indicates the part number listed is for reference only. See DESCRIPTION for possible service replacement.

(Continued)

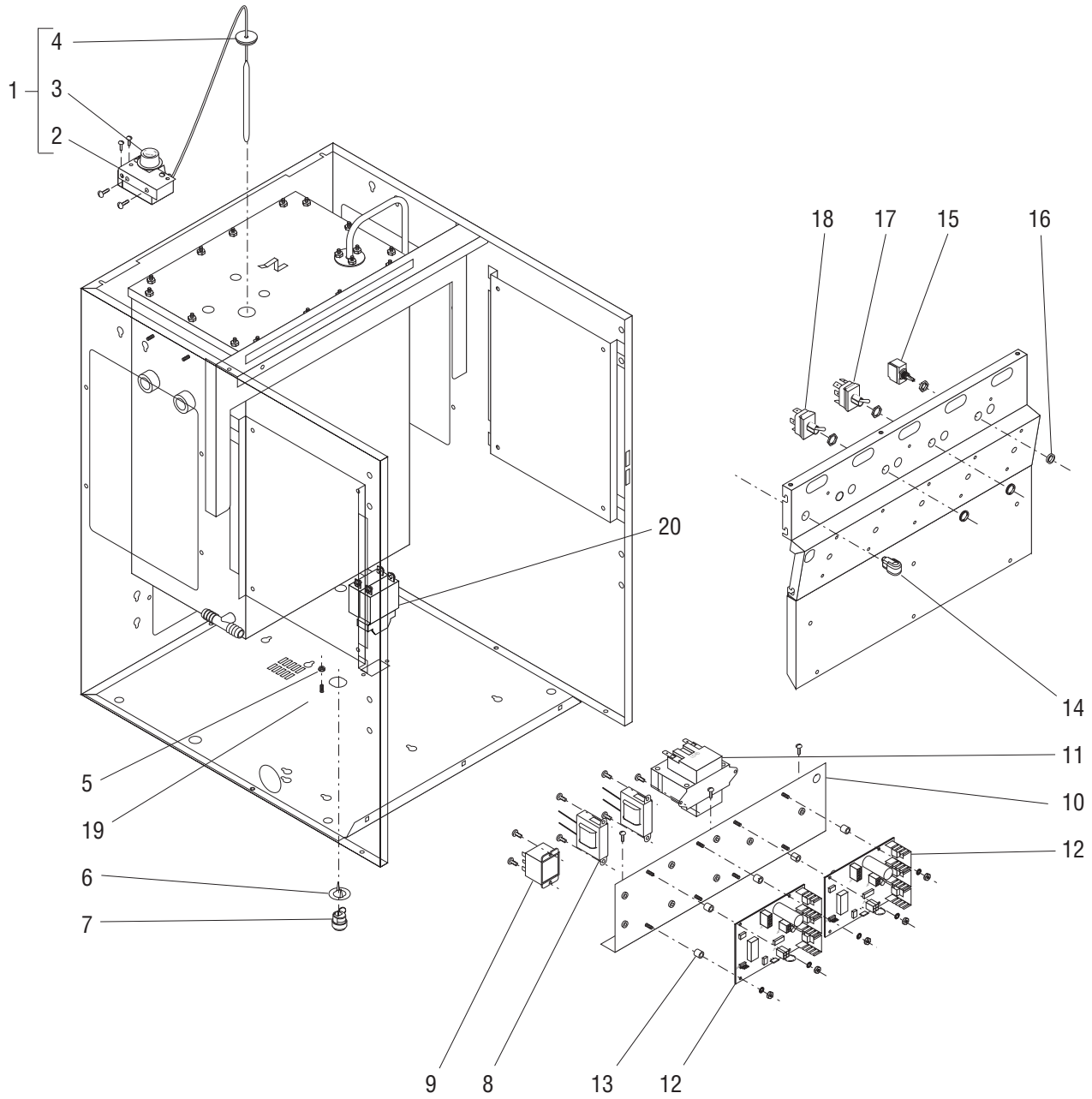

ELECTRICAL CONTROLS

ITEM	PART NO.	QTY.	DESCRIPTION
The following items are not illustrated			
21	20630.0008	1	Power Cord 120V
	28680.0001	1	Power Cord (FMD-5)(120/240V)(Models w/o Master ON/OFF Switch)
	28680.0004	1	Power Cord (FMD-5)(120/240V)(Models w/ Master ON/OFF Switch)
	27728.0002	1	Power Cord (FMD-5)(230V)
22	35101.0000	1	Wiring Harness, Switches (FMD-4)
	34984.0000	1	Wiring Harness, Switches (FMD-5)
23	35097.0000	1	Wiring Harness, High Voltage (FMD-4)(120V or 120/240V)
	35098.0000	1	Wiring Harness, High Voltage (FMD-4)(120/208)
	34983.0000	1	Wiring Harness, High Voltage (FMD-5)(120V)
	34983.0001	1	Wiring Harness, High Voltage (FMD-5)(120/240V)
	34983.0002	1	Wiring Harness (FMD-5)(230V)
24	35102.0000	1	Wiring Harness, Low Voltage (FMD-4)
	34982.0000	1	Wiring Harness, Low Voltage (FMD-5)
25	38920.0008	1	Wiring Harness, Master ON/OFF Switch
26	03851.0000	2	Wire Nut, TAN 2-22 AWG
27	28862.0000	1	Lead, jumper (Models w/o Cold Water Valve)

* Indicates the part number listed is for reference only. See DESCRIPTION for possible service replacement.

NUMERICAL INDEX

PART NO.	PAGE NO.	PART NO.	PAGE NO.	PART NO.	PAGE NO.	PART NO.	PAGE NO.
00450.0000.....	25	13255.0003.....	7	27543.1003.....	9	29642.1001.....	13,15
00619.0010.....	5	20201.0750.....	19	27543.1004.....	9	29713.0001.....	13
00656.0001.....	5	20201.4151.....	19	27543.1005.....	9	32283.0000.....	21
00713.0000.....	25	20203.0100.....	19	27543.1006.....	11	32306.0000.....	17
00715.0000.....	25	20377.0001.....	13	27619.0000.....	9	32337.0000.....	15
00720.0000.....	25	20630.0008.....	29	27728.0002.....	27	32359.0000.....	21
00824.0002.....	25	20762.0000.....	25	28061.0000.....	15	32383.0000.....	13,15
00831.0000.....	5	20960.0000.....	13,15	28067.0000.....	15	32386.0000.....	15
00908.0000.....	19	20976.0005.....	21	28095.0000.....	9	32812.0000.....	5
00938.0000.....	21	20976.0043.....	21	28206.0000.....	5	32824.0001.....	25
00942.0000.....	19	20976.0069.....	21	28224.0000.....	25	32906.0000.....	17
00943.0000.....	19	20976.1000.....	21	28295.0000.....	17	33045.0000.....	5
00946.0000.....	19	20976.1001.....	21	28295.0001.....	17	33606.0001.....	21
00970.0000.....	19,23,25	21355.0000.....	13	28296.1000.....	9	34392.0000.....	21
00973.0000.....	25	21357.0000.....	13	28297.0000.....	17	34489.1000.....	9
00976.0000.....	21	21358.0000.....	13	28322.0000.....	9	34489.1001.....	9
00991.0000.....	5	21436.0000.....	5	28325.0000.....	9	34492.0000.....	9
00991.0002.....	13,15	21465.0001.....	13	28327.0000.....	25	34584.0000.....	19
01308.0000.....	9,11	21746.0000.....	13	28328.0008.....	7	34607.0000.....	15
01308.0002.....	25	21747.0001.....	13	28328.0009.....	7	34608.1000.....	5
01311.0000.....	7,9,13,15,25	21801.0015.....	19,23	28335.0000.....	9	34608.1001.....	5
01311.0001... 5,7,13,15,17,25		22728.0000.....	19	28336.0000.....	11	34608.1002.....	5
01311.0003.....	5,25	23164.0002.....	5	28366.1001.....	7	34608.1003.....	5
01315.0000.....	5	23279.0000.....	9	28368.0000.....	5	34610.0000.....	7
01326.0000.....	23	23522.1000.....	25	28368.0004.....	5	34611.0000.....	5
01327.0000.....	25	23697.0000.....	25	28424.1000.....	13,15	34614.0000.....	15
01501.0000.....	19	24733.0010.....	17	28425.0000.....	15	34615.0000.....	15
01510.0000.....	25	24733.0011.....	23	28428.1000.....	17	34621.1000.....	7
01511.0000.....	13,15	25732.0000.....	17	28428.1002.....	17	34621.1001.....	7
01512.0000.....	25	25733.0000.....	17	28526.0002.....	23	34625.0000.....	25
01514.0000.....	21	25734.1000.....	17	28526.0008.....	19	34625.0002.....	25
01522.0000.....	13	25736.0000.....	17	28526.0012.....	23	34627.1000.....	5
01666.0001.....	26	25743.0000.....	15	28526.0016.....	23	34669.0000.....	13
02301.0001.....	26	25794.0001.....	13,15	28526.0023.....	23	34671.0000.....	5
02308.0000.....	7,19,25	25803.0000.....	23	28526.1001.....	19,23	34672.0000.....	13
02322.0002.....	21	25892.0000.....	13	28526.1002.....	19,23	34716.0000.....	7
02328.0002.....	9	25902.0000.....	17	28526.1003.....	19,23	34717.0000.....	7
02336.0000.....	17	25903.0000.....	13,15	28679.0000.....	13	34718.0000.....	9
02434.0009.....	17	26112.0001.....	15	28680.0001.....	27	34719.0001.....	9
02434.0010.....	19	26239.0000.....	9	28680.0004.....	27	34720.0001.....	9
02434.1000.....	17,19	26247.0000.....	13,15	28698.0000.....	13	34721.0000.....	9
02536.0000.....	19	26247.1000.....	13,15	28856.1000.....	25	34722.0000.....	9
03633.0000.....	19	26356.0000.....	17	28857.1000.....	25	34725.0001.....	5
03803.0000.....	19	26356.1000.....	17	28862.0000.....	25	34725.0000.....	5
03851.0000.....	27	26369.0000.....	23	28864.0004.....	17	34768.0000.....	21
03996.0000.....	5	26401.0000.....	13,15	28865.0000.....	17	34820.0000.....	5
04797.0000.....	19	26523.0000.....	5	28866.0000.....	17	34820.0001.....	5
05515.0000.....	19	26524.0000.....	5	28867.0000.....	17	34827.0000.....	9
07073.1000.....	25	26528.0000.....	5	28872.0000.....	5	34866.0000.....	19
07412.1002.....	19	26537.0000.....	11	28964.0003.....	9	34971.0000.....	5
11630.0001.....	21	26537.0001.....	11	28964.0004.....	9	34972.0000.....	5
12422.0001.....	21,23	26537.0003.....	11	29014.1000.....	13	34982.0000.....	27
12517.0001.....	9	26940.0002.....	15	29308.0000.....	9	34983.0000.....	27
12756.0000.....	21	26940.0003.....	13	29329.1000.....	19	34983.0001.....	27
12757.0000.....	21	27298.0500.....	9	29576.0000.....	23	34983.0002.....	27

NUMERICAL INDEX

PART NO.	PAGE NO.	PART NO.	PAGE NO.	PART NO.	PAGE NO.	PART NO.	PAGE NO.
34984.0000.....	27						
34985.0000.....	11						
34993.0000.....	21						
35011.0000.....	19						
35012.0000.....	19						
35020.0000.....	19						
35076.0000.....	9						
35076.0001.....	9						
35079.1000.....	17						
35094.1000.....	21						
35097.0000.....	27						
35098.0000.....	27						
35099.0000.....	11						
35101.0000.....	27						
35102.0000.....	27						
35103.0000.....	9						
35134.0000.....	21						
35207.0000.....	25						
35207.0002.....	25						
36194.0000.....	7						
36233.1000.....	21						
36233.0001.....	21						
36378.0001.....	21						
37297.0006.....	21						
37881.0000.....	7						
37970.0000.....	23						
37983.1000.....	19						
37983.1001.....	19						
38019.0000.....	7						
38026.0000.....	7						
38894.0001.....	25						
38920.0008.....	27						
39285.1001.....	23						
39285.1002.....	23						
39417.0001.....	25						
39642.0000.....	25						
39803.0000.....	7						
40781.0000.....	9						
40782.0000.....	9						
40791.1006.....	25						
41259.0001.....	19						
41266.0000.....	19						
41280.0000.....	19						
42996.1000.....	25						
43644.0000.....	21						
45964.1000.....	23						