

BUNN®

FMD-1

FMD-2

S/N FMD0013000 - UP

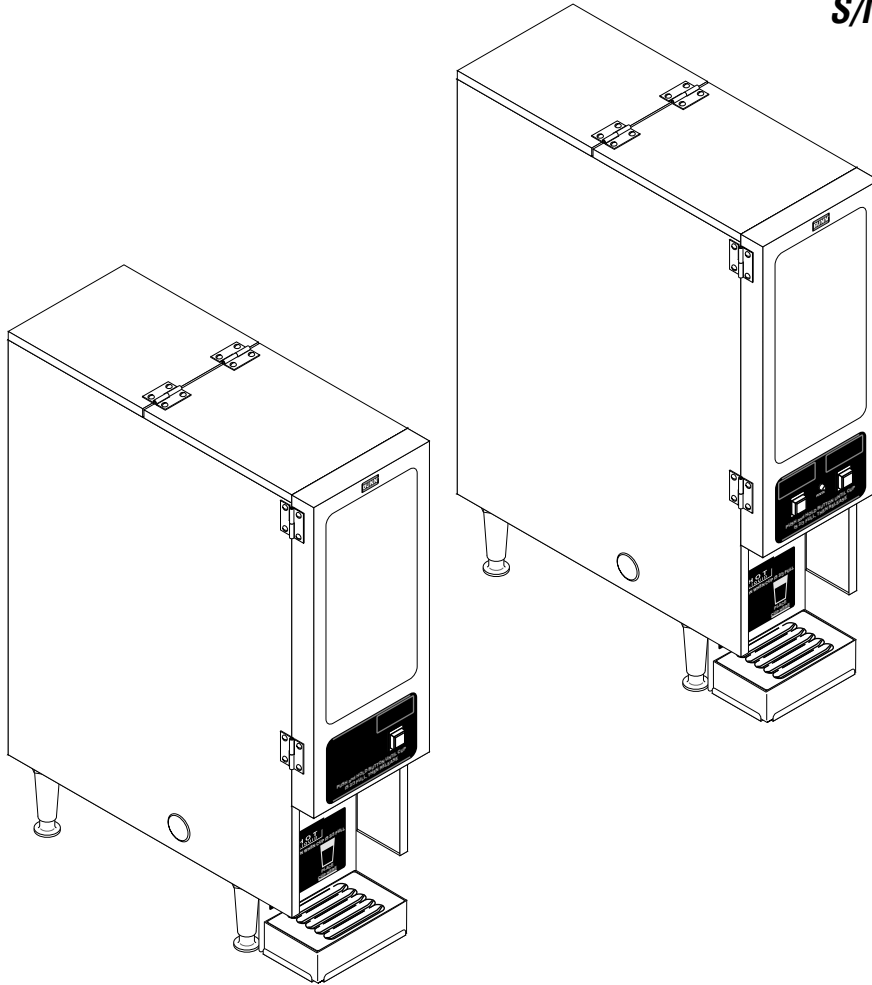

ILLUSTRATED PARTS CATALOG

Designs, materials, weights, specifications, and dimensions for equipment or replacement parts are subject to change without notice.

BUNN-O-MATIC CORPORATION

POST OFFICE BOX 3227

SPRINGFIELD, ILLINOIS 62708-3227

PHONE: (217) 529-6601 FAX: (217) 529-6644

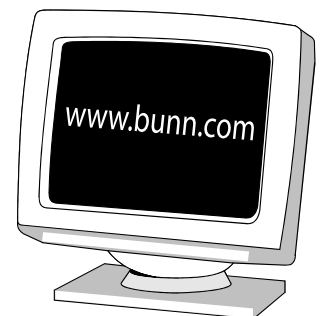

BUNN-O-MATIC COMMERCIAL PRODUCT WARRANTY

Bunn-O-Matic Corp. ("BUNN") warrants equipment manufactured by it as follows:

- 1) Airpots, thermal carafes, decanters, GPR servers, iced tea/coffee dispensers, MCR/MCP/MCA single cup brewers, thermal servers and ThermoFresh® servers (mechanical and digital) 1 year parts and 1 year labor.
- 2) All other equipment - 2 years parts and 1 year labor plus added warranties as specified below:
 - a) Electronic circuit and/or control boards - parts and labor for 3 years.
 - b) Compressors on refrigeration equipment - 5 years parts and 1 year labor.
 - c) Grinding burrs on coffee grinding equipment to grind coffee to meet original factory screen sieve analysis - parts and labor for 4 years or 40,000 pounds of coffee, whichever comes first.

These warranty periods run from the date of installation BUNN warrants that the equipment manufactured by it will be commercially free of defects in material and workmanship existing at the time of manufacture and appearing within the applicable warranty period. This warranty does not apply to any equipment, component or part that was not manufactured by BUNN or that, in BUNN's judgment, has been affected by misuse, neglect, alteration, improper installation or operation, improper maintenance or repair, non periodic cleaning and descaling, equipment failures related to poor water quality, damage or casualty. In addition, the warranty does not apply to replacement of items subject to normal use including but not limited to user replaceable parts such as seals and gaskets. This warranty is conditioned on the Buyer 1) giving BUNN prompt notice of

any claim to be made under this warranty by telephone at (217) 529-6601 or by writing to Post Office Box 3227, Springfield, Illinois 62708-3227; 2) if requested by BUNN, shipping the defective equipment prepaid to an authorized BUNN service location; and 3) receiving prior authorization from BUNN that the defective equipment is under warranty.

THE FOREGOING WARRANTY IS EXCLUSIVE AND IS IN LIEU OF ANY OTHER WARRANTY, WRITTEN OR ORAL, EXPRESS OR IMPLIED, INCLUDING, BUT NOT LIMITED TO, ANY IMPLIED WARRANTY OF EITHER MERCHANTABILITY OR FITNESS FOR A PARTICULAR PURPOSE. The agents, dealers or employees of BUNN are not authorized to make modifications to this warranty or to make additional warranties that are binding on BUNN. Accordingly, statements by such individuals, whether oral or written, do not constitute warranties and should not be relied upon.

If BUNN determines in its sole discretion that the equipment does not conform to the warranty, BUNN, at its exclusive option while the equipment is under warranty, shall either 1) provide at no charge replacement parts and/or labor (during the applicable parts and labor warranty periods specified above) to repair the defective components, provided that this repair is done by a BUNN Authorized Service Representative; or 2) shall replace the equipment or refund the purchase price for the equipment.

THE BUYER'S REMEDY AGAINST BUNN FOR THE BREACH OF ANY OBLIGATION ARISING OUT OF THE SALE OF THIS EQUIPMENT, WHETHER DERIVED FROM WARRANTY OR OTHERWISE, SHALL BE LIMITED, AT BUNN'S SOLE OPTION AS SPECIFIED HEREIN, TO REPAIR, REPLACEMENT OR REFUND.

In no event shall BUNN be liable for any other damage or loss, including, but not limited to, lost profits, lost sales, loss of use of equipment, claims of Buyer's customers, cost of capital, cost of down time, cost of substitute equipment, facilities or services, or any other special, incidental or consequential damages.

392, A Partner You Can Count On, Air Infusion, AutoPOD, AXIOM, BrewLOGIC, BrewMETER, Brew Better Not Bitter, BrewWISE, BrewWIZARD, BUNN Espresso, BUNN Family Gourmet, BUNN Gourmet, BUNN Pour-O-Matic, BUNN, BUNN with the stylized red line, BUNNlink, Bunn-OMatic, Bunn-O-Matic, BUNNserve, BUNNSERVE with the stylized wrench design, Cool Froth, DBC, Dr. Brew stylized Dr. design, Dual, Easy Pour, EasyClear, EasyGard, FlavorGard, Gourmet Ice, Gourmet Juice, High Intensity, iMIX, Infusion Series, Intellisteam, My Café, Phase Brew, PowerLogic, Quality Beverage Equipment Worldwide, Respect Earth, Respect Earth with the stylized leaf and coffee cherry design, Safety-Fresh, savemycoffee.com, Scale-Pro, Silver Series, Single, Smart Funnel, Smart Hopper, SmartWAVE, Soft Heat, SplashGard, The Mark of Quality in Beverage Equipment Worldwide, ThermoFresh, Titan, trifacta, TRIFECTA (stylized logo), Velocity Brew, Air Brew, Beverage Bar Creator, Beverage Profit Calculator, Brew better, not bitter., Build-A-Drink, BUNNSource, Coffee At Its Best, Cyclonic Heating System, Daypart, Digital Brewer Control, Element, Milk Texturing Fusion, Nothing Brews Like a BUNN, Picture Prompted Cleaning, Pouring Profits, Signature Series, Sure Tamp, Tea At Its Best, The Horizontal Red Line, Ultra are either trademarks or registered trademarks of Bunn-O-Matic Corporation. The commercial trifacta® brewer housing configuration is a trademark of Bunn-O-Matic Corporation.

TABLE OF CONTENTS

TITLE	PAGE NO.
Auger Drive and Hopper Assembly - FMD-1	12
Auger Drive and Hopper Assembly - FMD-2	14
Covers, Panels and Drip Tray	4
Dispense Valve and Lines.....	22
Door, Lamp, Dispense Switch and Panels.....	8
Electrical Controls - FMD-1	24
Electrical Controls - FMD-2	26
Fill Valve and Lines.....	20
Mixing/Whipper Chambers and Drive Motor	16
Numerical Index.....	28
Tank, Heater and Overflow Protection	18

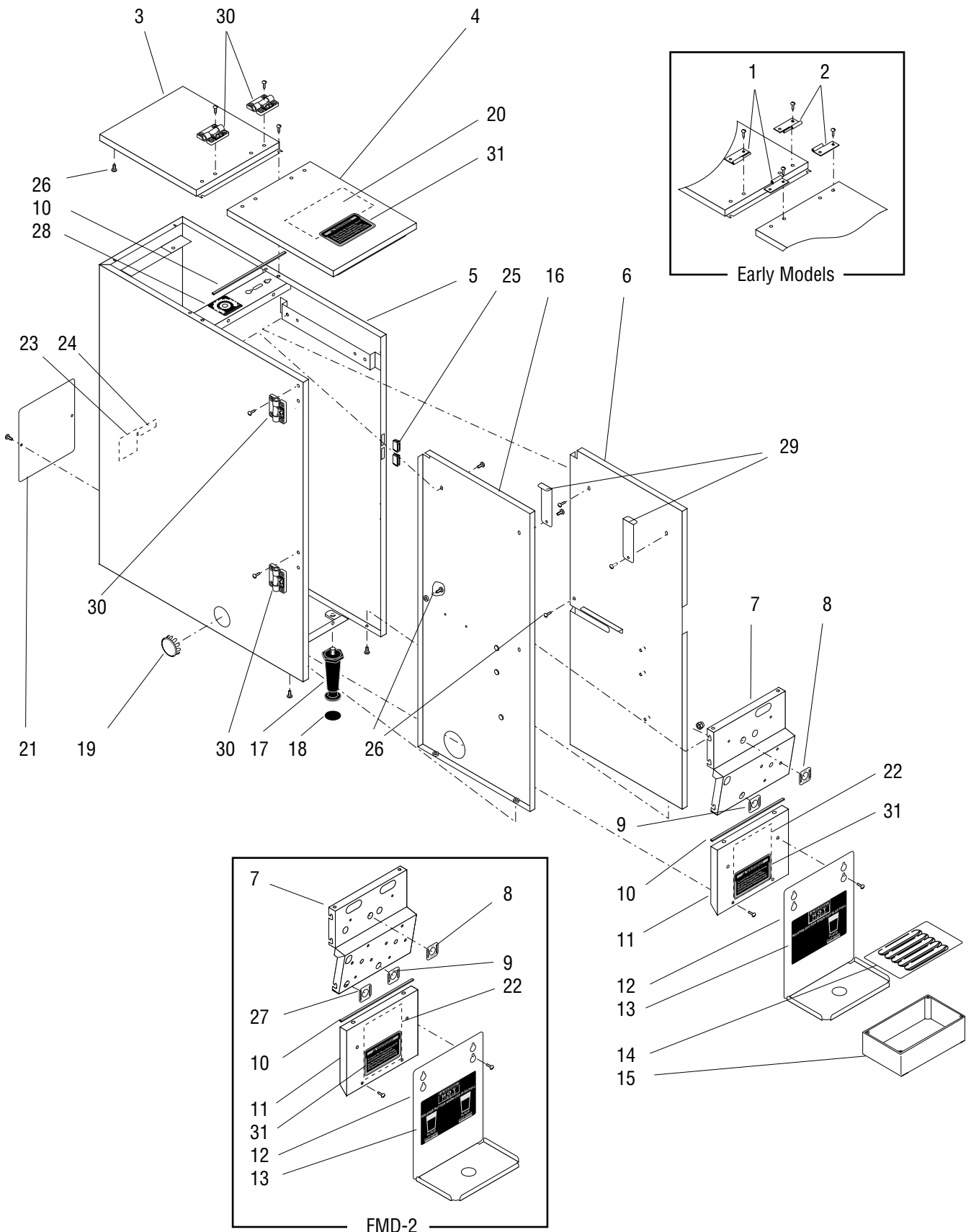

COVERS, PANELS AND DRIP TRAY

ITEM	PART NO.	QTY.	DESCRIPTION
1	29027.0001	2	Hinge, Left (Early Models)
	02322.0002	8	Screw, Pan Head - BLK #8-32 x .375"
2	29027.0000	2	Hinge, Right (Early Models)
	02322.0002	8	Screw, Pan Head - BLK #8-32 x .375"
3	28952.0001	1	Cover, Top Rear - BLK
	02308.0000	2	Screw, Pan Head #8-32 x .375"
4	28954.0001	1	Cover, Top Front (Also order item 20)
5	29172.0000	1	Housing W/Decals (Includes items 23 & 24, also order item 28)
6	29939.0001	1	Panel, Right
	01311.0001	2	Screw, Truss Head - Locking #8-32 x .25"
	02322.0002	2	Screw, Pan Head - BLK #8-32 x .375"
7	28937.0000	1	Panel, Whipper Motor Mounting (Also order items 8 & 9) (FMD-1)
	28937.0001	1	Panel, Whipper Motor Mounting (Also order items 8, 9 & 27) (FMD-2)
	00991.0000	6	Nut, Elastic Lock #8-32
8	26524.0000	1	Decal, Tank Heater Switch
9	26523.0000	1	Decal, Rinse/Run Switch
10	-----	2	Gasket, Foam W/Adhesive (Order item 32)
11	29174.0000	1	Cover, Lower Front Access (Includes item 22) (FMD-1)
	29174.0001	1	Cover, Lower Front Access (Includes item 22) (FMD-2)
	01311.0003	2	Screw, Truss Head - BLK #8-32 x .25"
12	29173.0000	1	Panel W/Decal, Splash (Includes item 13) (FMD-1)
	29173.0001	1	Panel W/Decal, Splash (Includes item 13) (FMD-2)
	01311.0000	2	Screw, Truss Head #8 - 32 x .25"
13	28328.0004	1	Decal, Caution-Hot Liquid & Cup Placement (FMD-1)
	28328.0005	1	Decal, Caution-Hot Liquid & Cup Placement (FMD-2)
14	28966.0000	1	Cover, Drip Tray
15	02571.0000	1	Drip Tray
16	34972.0000*	1	Panel, Left
	01311.0001	2	Screw, Truss Head - Locking #8-32 x .25"
	02322.0002	2	Screw, Pan Head - BLK #8-32 x .375"
17	26528.0000	4	Leg, 4.0" Adjustable (Also see item 33)
18	03996.0000	4	Pad, Rubber 1.25" Dia. (Also see item 33)
19	23164.0002	1	Plug, Hole 1.50" Dia. - BLK
20	28368.0001	1	Decal, Thermostat Adjustment (Invensys Thermostat)
	28368.0003	1	Decal, Thermostat Adjustment (Cootherm Thermostat)
21	28941.0001	1	Panel, Rear Access
	01311.0000	2	Screw, Truss Head #8 - 32 x .25"

(Continued)

* Indicates the part number listed is for reference only. See DESCRIPTION for possible service replacement.

(Continued)

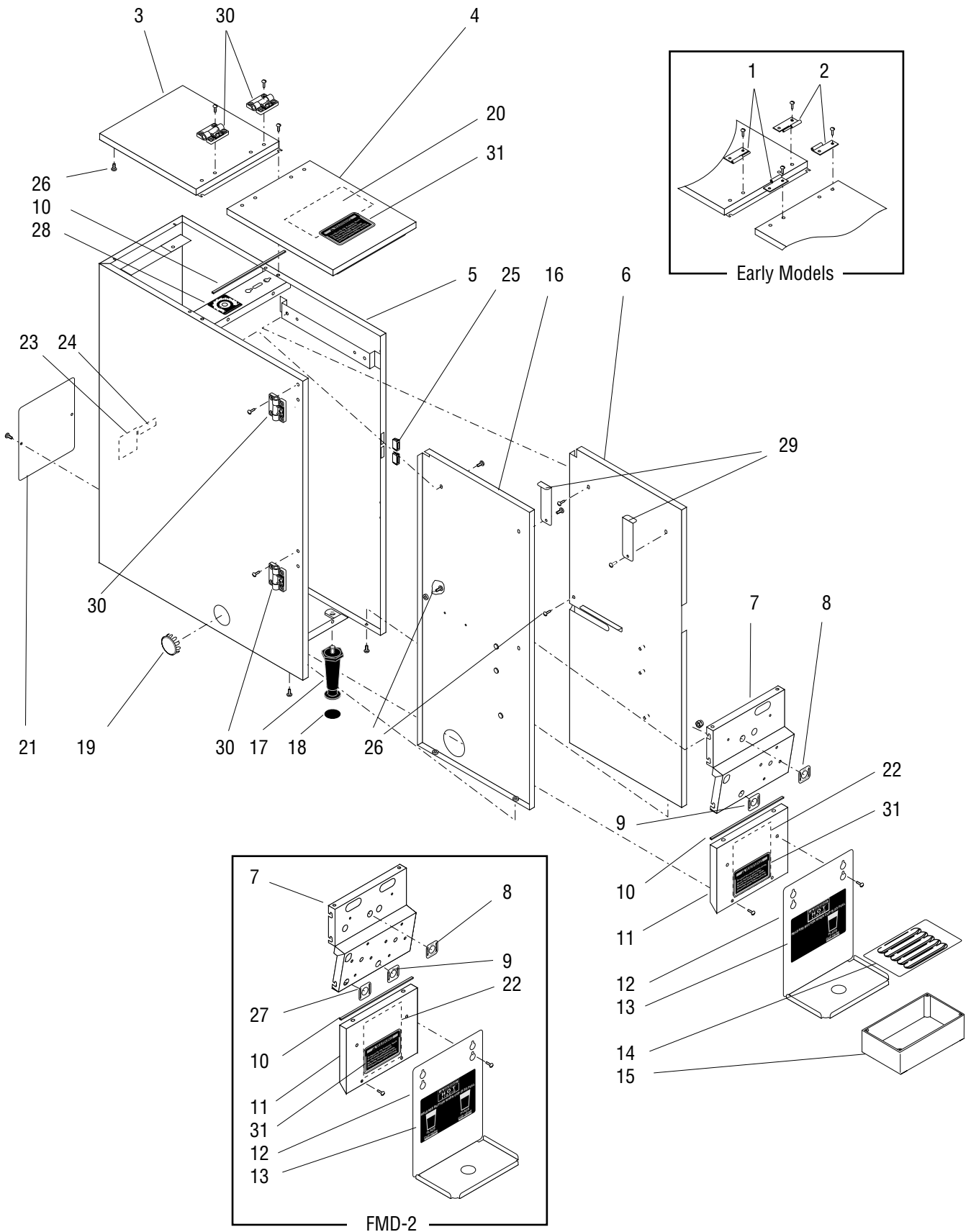

COVERS, PANELS AND DRIP TRAY

ITEM	PART NO.	QTY.	DESCRIPTION
22	29096.0000	1	Schematic, 120V, 120/208V & 120/240V (FMD-1)
	29096.0001	1	Schematic, 120V, 120/208V & 120/240V (FMD-2)
23	00831.0000	1	Decal, Warning-Electrical
24	00656.0001	1	Decal, Comply to Plumbing Code
25	21436.0000	2	Catch, Magnetic
26	01311.0001	4	Screw, Truss Head - Locking #8-32 x .375"
27	28872.0000	1	Decal, Increase/Decrease (FMD-2)
28	27096.0000	1	Decal, Potentiometer Adjustment (FMD-1)
29	28910.0000	1	Bracket Kit, Cover Retainer (Includes two brackets) (Optional)
30	26504.0000	4	Hinge, Adjustable (Late Models)
	02322.0002	16	Screw, Pan Head - BLK #8-32 x .375"
31	37881.0000	2	Decal, No Serviceable Parts
32	28366.1000	-	Gasket, Foam W/Adhesive - 12" LG
	28366.1001	-	Gasket, Foam W/Adhesive - 36" LG
	28366.1002	-	Gasket, Foam W/Adhesive - 120" LG
33	13255.0003	-	Kit, Leg 4.0" Adjustable (Includes 4 each of items 17 & 18) (Not Illustrated)

* Indicates the part number listed is for reference only. See DESCRIPTION for possible service replacement.

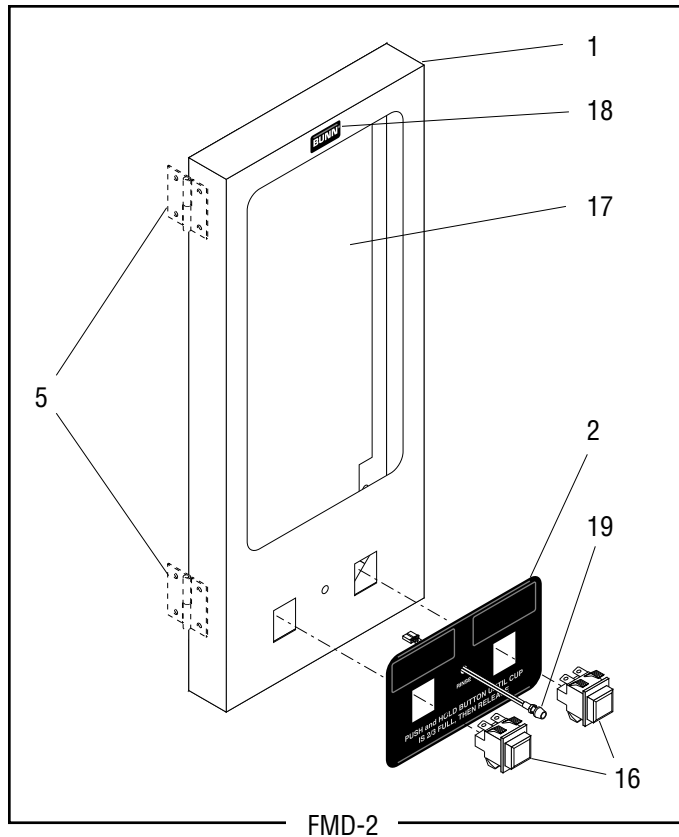
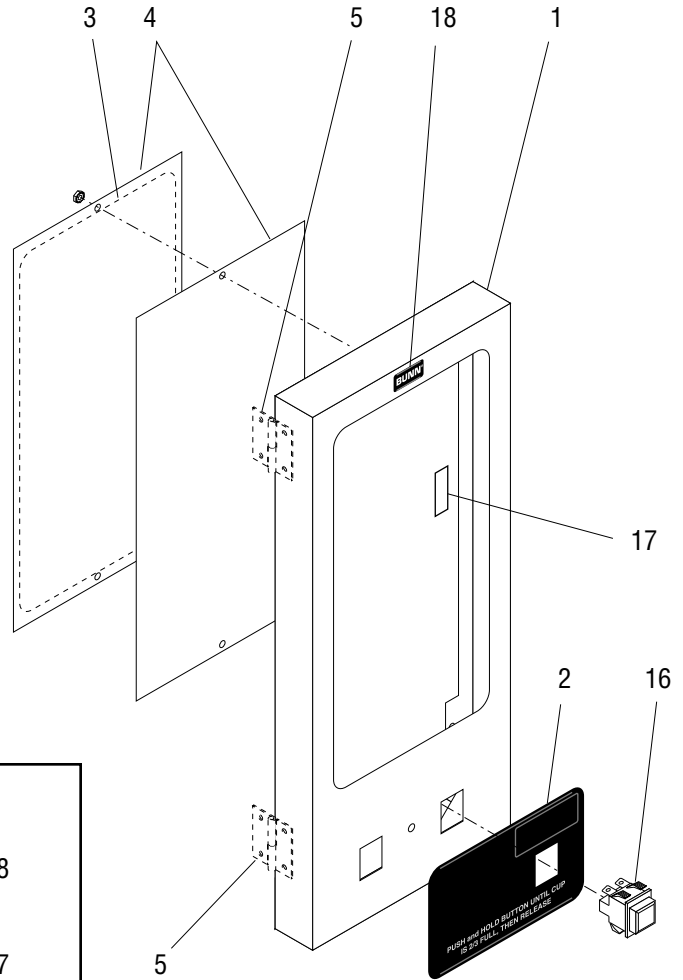
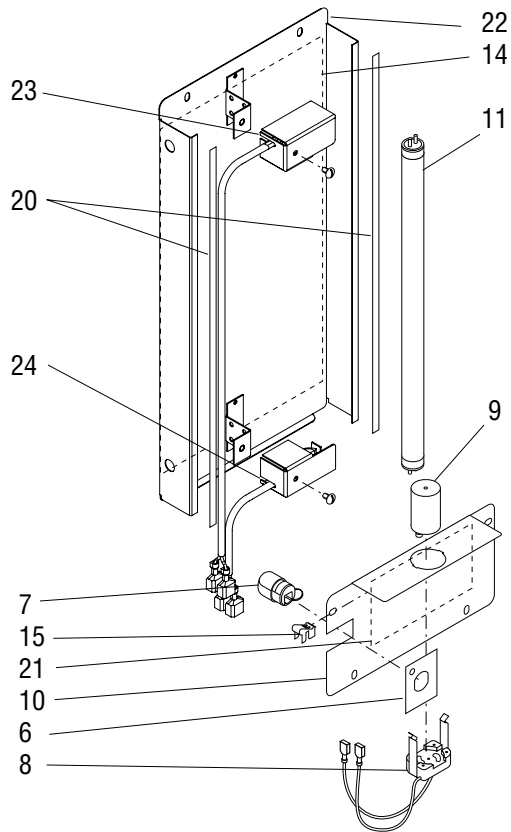

FMD-2

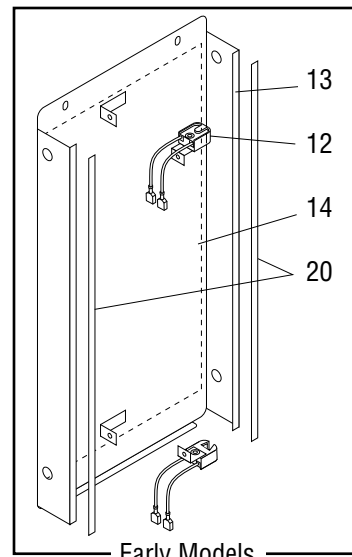

Early Models

P1616.60

DOOR, LAMP, DISPENSE SWITCH AND PANELS

ITEM	PART NO.	QTY.	DESCRIPTION
1	29175.0000	1	Door W/Decals (Includes items 2, 17 and 18) (FMD-1)
	29175.0001	1	Door W/Decals (Includes items 2, 17 and 18) (FMD-2)
2	28964.0000	1	Decal, Door Front (FMD-1)
	28964.0001	1	Decal, Door Front (FMD-2)
3	29106.0000	1	Display, Graphic - Drink
	29106.0001	1	Display, Graphic - Soup
4	28963.0000	2	Window, Door
	00970.0000	2	Nut, Keps #8-32
5	-----	-	Hinge, Door (See Covers, Panels and Drip Tray)
6	26892.0000	1	Plate, Strain Relief
7	26444.0000	2	Bushing, Strain Relief
8	28325.0000	1	Socket W/Terminals, Starter 120V
	40782.0000	1	Socket W/Terminals, Starter 230V
9	27619.0000	1	Starter, Lamp
10	28962.0000	1	Panel, Door - Lower 120V
	40780.0000	1	Panel, Door - Lower 230V
	01311.0000	4	Screw, Pan Head #8-32 x .250"
11	26239.0000	1	Lamp, Fluorescent - 8 Watts
12	28322.0000	2	Lamp Holder, Fluorescent (Early Models)
	02328.0002	2	Screw, Pan Head #6 - 32 x .188"
13	29176.0000	1	Panel W/Decal, Door - Upper (Includes item 14 & 20) (FMD-1)(Early Models)
	29176.0001	1	Panel W/Decal, Door - Upper (Includes item 14 & 20) (FMD-2) (Early Models)
	01311.0000	2	Screw, Truss Head #8 - 32 x .25"
14	29161.0000	1	Decal, Cleaning (FMD-1)
	29161.0001	1	Decal, Cleaning (FMD-2)
15	28335.0000	1	Clip, Ground
16	28296.1000	1	Switch Assembly, Dispense (One additional used on FMD-2 dispensers)
17	27298.0500	1	Striker Assy.
18	23279.0000	1	Decal, BUNN
19	12517.0001	1	L.E.D. W/Terminals (Not used on FMD-1)
	25292.0000	1	Lockwasher M6
	34130.0000		Nut M6
20	-----	2	Gasket, Foam W/Adhesive - 13.088" LG (Order item 28)
21	29308.0000	1	Decal, Hopper Installation
22	28960.0001	1	Panel, Upper (Late Models)
	01311.0000	2	Screw, Truss Head #8 - 32 x .25"
23	27543.1005	1	Lampholder Assy, Upper (Late Models)
	01308.0000	1	Screw, Truss Head #6-32 x .25"
24	27543.1006	1	Lampholder Assy, Lower (Late Models)
	01308.0000	1	Screw, Truss Head #6-32 x .25"

The following items are not illustrated

25	28990.0000	1	Wiring Harness, Door Interconnect 120V (Includes item 6 & one of item 7) (FMD-1)
	29119.0000	1	Wiring Harness, Door Interconnect 120V (Includes item 6 & one of item 7) (FMD-2)

(Continued)

* Indicates the part number listed is for reference only. See DESCRIPTION for possible service replacement.

(Continued)

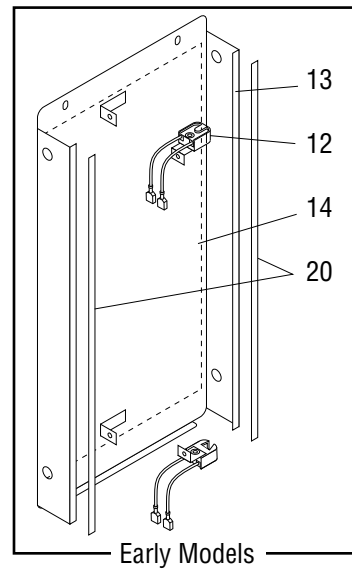
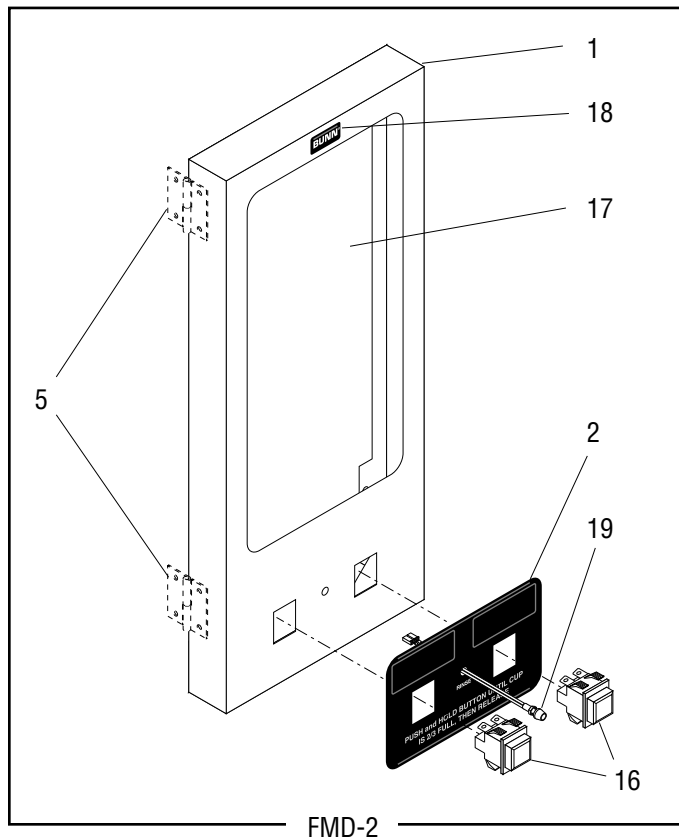
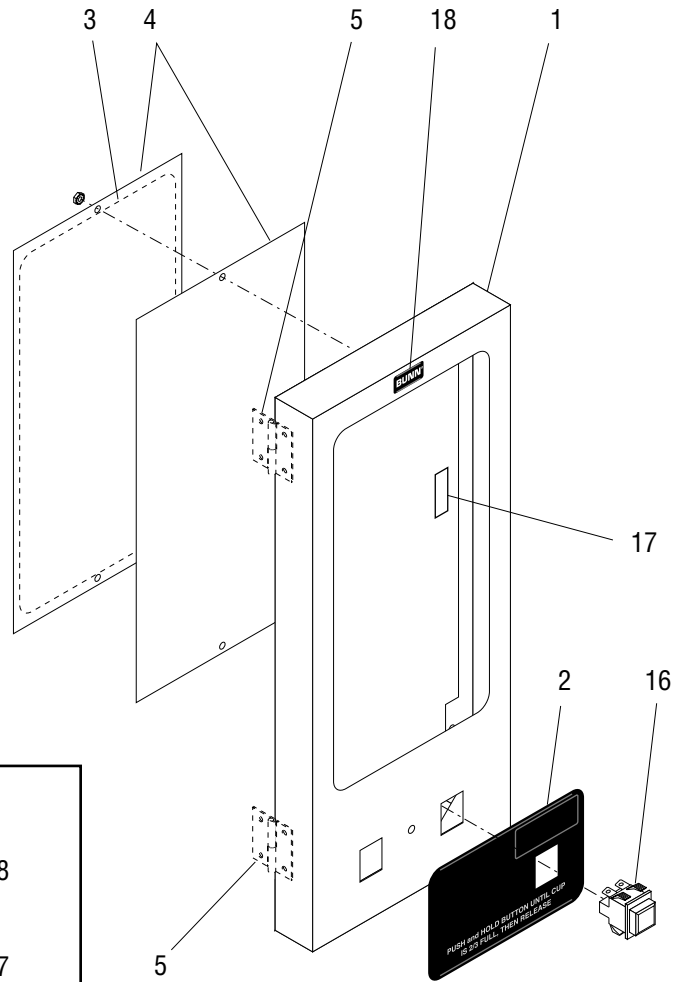
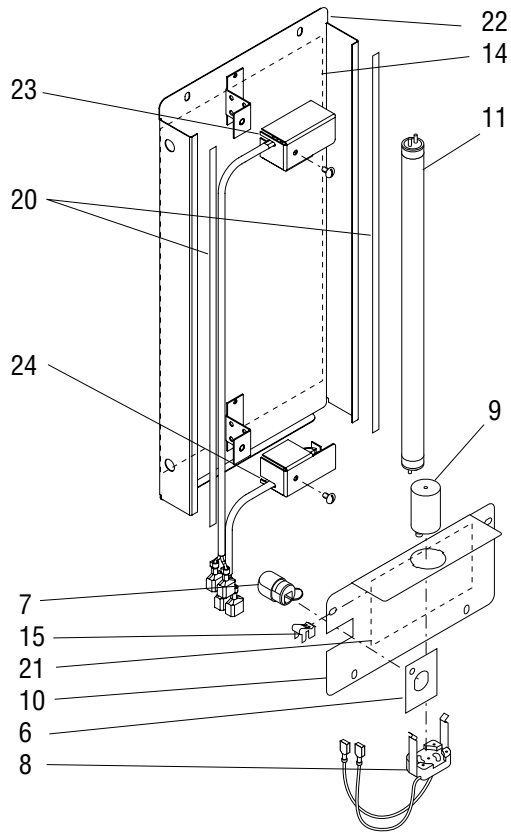

P1616.60

DOOR, LAMP, DISPENSE SWITCH AND PANELS

ITEM	PART NO.	QTY.	DESCRIPTION
26	28336.0000	1	Wiring Harness, Door 120V
27	26537.0000	1	Decal, Flavors (Almond Amaretto, Cappuccino, French Vanilla, Hazelnut, Chocolate Raspberry, Cappuccino Supreme, Hot Chocolate and Raspberry Mocha)
	26537.0001	1	Decal, Flavors (Swiss Mocha, Mocha, Raspberry Vanilla, Irish Creme, Coffee, Original, Chocolate French Vanilla and Butter Pecan)
	26537.0003	1	Decal, Flavors (White Chocolate, Cinnamon Vanilla Nut, Decaf, Regular, Apple Cider, Fat Free French Vanilla and Cinnamon Vanilla)
	28833.0000	1	Decal, Soup Flavors (Cream of Chicken, Mushroom, Tomato, Broccoli, Potato and Cheddar Cheese)
	28833.0001	1	Decal, Soup Flavors (Chicken Consomme, French Onion,Chicken Noddle, Beef Noddle, Seafood Bisque and Clam Chowder)
28	28366.1001	-	Gasket, Foam W/Adhesive - 36" LG
	28366.1002	-	Gasket, Foam W/Adhesive - 120" LG
29	21004.0338*	1	Lead 18AWG, GRN 6.0" (Door Grounding)

* Indicates the part number listed is for reference only. See DESCRIPTION for possible service replacement.

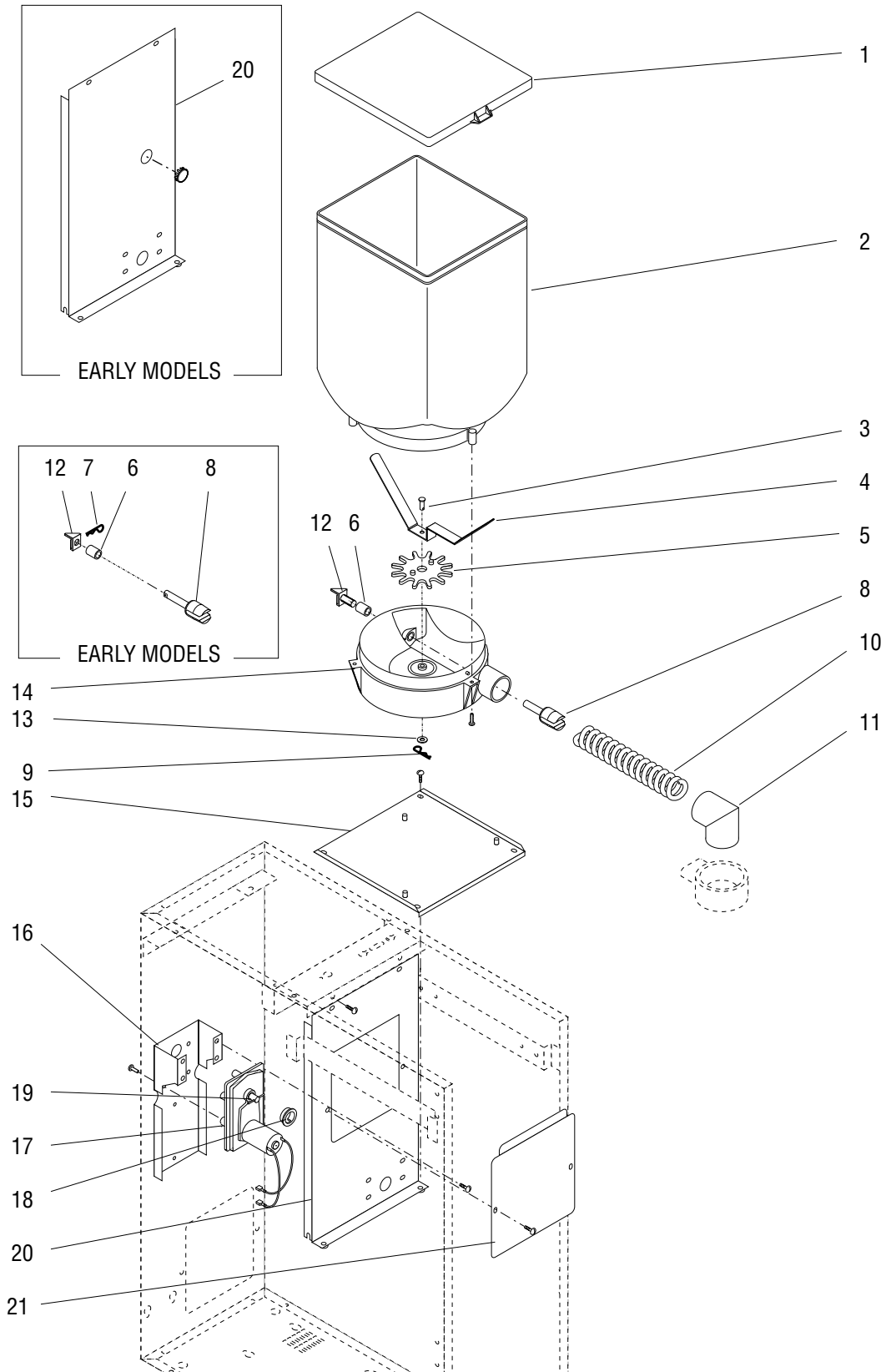

AUGER DRIVE AND HOPPER ASSEMBLY - FMD-1

ITEM	PART NO.	QTY.	DESCRIPTION
-	29014.1000	1	Hopper & Auger Drive Assy (Includes items 1 thru 14)
1	28679.0000	1	Lid, Hopper
2	28698.0000	1	Hopper
	20377.0001	3	Screw, Pan Head #4-20 x .50"
3	21357.0000	1	Shaft, Wiper
4	21747.0001	1	Blade, Wiper
5	21746.0000	1	Gear, Wiper Drive
6	25892.0000	1	Spacer, .312" I.D. x .437 O.D. x .56 LG
7	21358.0000	1	Clip, Retainer
8	-----	1	Shaft, Auger Drive (Early models order item 22)
	26940.0003	1	Shaft, Auger Drive (Late models)
9	21358.0000	1	Clip, Retainer
10	21355.0000	1	Auger, Wire
11	25903.0000	1	Elbow, Ejector
12	-----	1	Bracket, Auger Drive (Early models order item 22)
	32383.0000	1	Bracket, Auger Drive (Late models)
13	01522.0000	1	Washer, .203" I.D. x .50" O.D.
14	21465.0001	1	Base, Hopper
15	28942.0000	1	Panel, Hopper Support
	01311.0000	4	Screw, Truss Head # 8 - 32 x .25"
16	25794.0002	1	Bracket, Motor Mounting
	01311.0001	4	Screw, Truss Head 8 - 32 x .25" Locking
17	29642.1000	1	Gearmotor W/Pin, Auger (Includes item 19)
	01311.0000	4	Screw, Truss Head 8 - 32 x .25"
18	26401.0000	1	Dust Seal, Hopper Motor
19	26247.0000	1	Pin, Spring .094" Dia. x 1.0"
	26247.1000	-	Kit, Spring Pin (Includes 6 Pins)
20	-----	1	Panel, Motor Mounting (Early Models. Not available, order late model bracket)
	28946.0000	1	Panel, Motor Mounting (Late Models)
	01311.0001	2	Screw, Truss Head - Locking #8-32 x .25"
	00619.0009	1	Plug, Hole .688" Dia. (Early Models only)
21	29575.0000	1	Panel, Dispense Valve Access (Late Models only)
	01311.0000	2	Screw, Truss Head #8-32 x .25"
22	32394.0001	-	Kit, Auger Drive Shaft (Converts early model Drive Shaft to late model Drive Shaft)

* Indicates the part number listed is for reference only. See DESCRIPTION for possible service replacement.

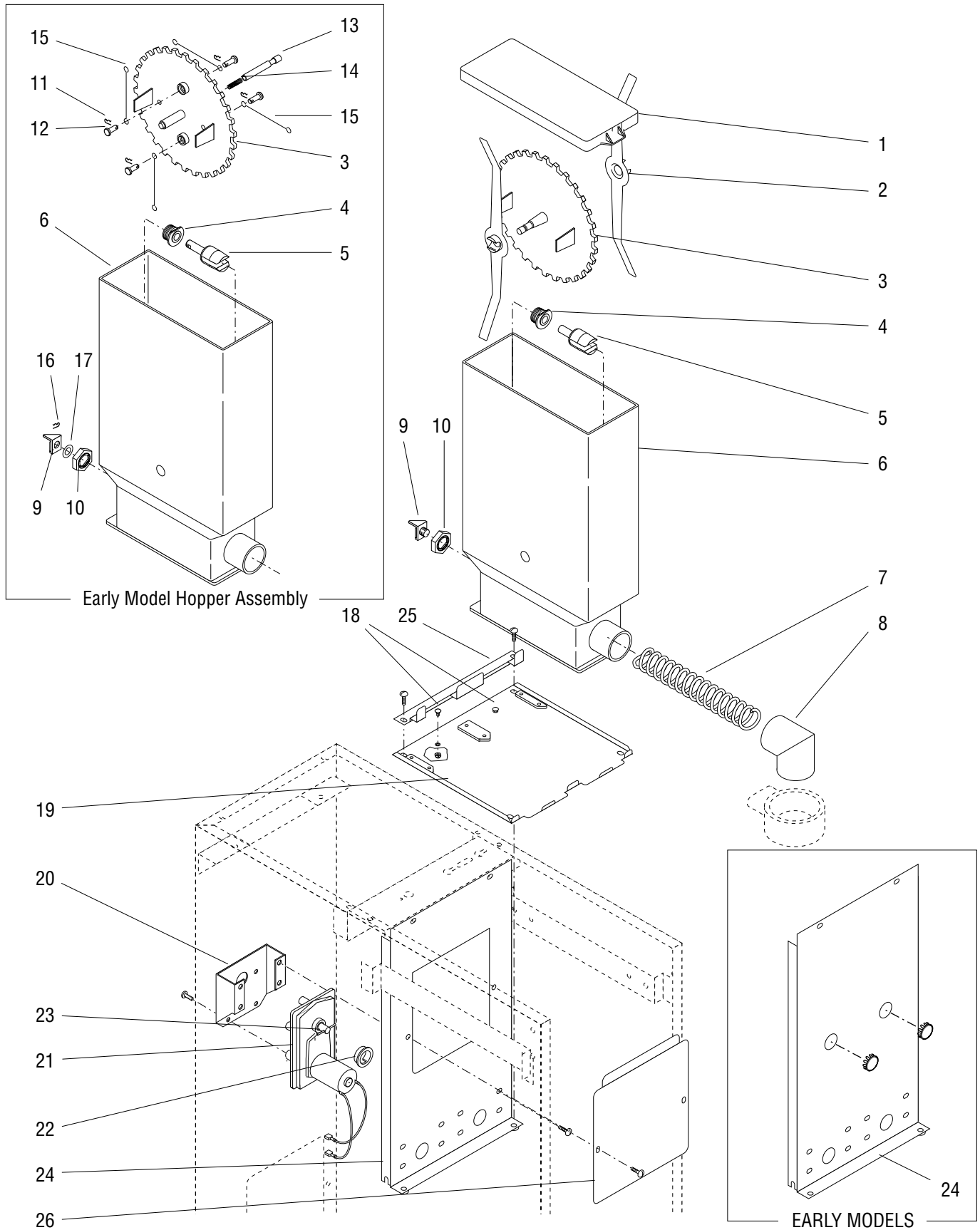

AUGER DRIVE AND HOPPER ASSEMBLY - FMD-2

ITEM	PART NO.	QTY.	DESCRIPTION
-	28424.1000	2	Hopper Assy (22 Tooth Agitator Disk)(Includes items 1 thru 10)
	28424.1002	2	Hopper Assy (30 Tooth Agitator Disk)(Includes items 1 thru 10)
1	28061.0000	1	Lid, Hopper
2	32337.0000	2	Mixing Blade (Late models)
3	26435.0000	1	Disk, Agitator (22 Tooth)
	26435.0001	1	Disk, Agitator (30 Tooth)
	32386.0000	1	Disk, Agitator (22 Tooth)
	32386.0001	1	Disk, Agitator (30 Tooth)
			} Early models
			} Late models
4	28067.0000	1	Bushing, Auger Drive Shaft
5	-----	1	Shaft, Auger Drive (Early models order item 28)
	26940.0002	1	Shaft, Auger Drive (Late models)
6	28425.0000	1	Hopper
7	26112.0001	1	Auger, Wire (Use w/22 Tooth Agitator Disk)
	21355.0001	1	Auger, Wire (Use w/30 Tooth Agitator Disk)
8	25903.0000	1	Elbow, Ejector
9	-----	1	Bracket, Auger Drive (Early models order item 28)
	32383.0000	1	Bracket, Auger Drive (Late models)
10	25743.0000	1	Locknut
11	21358.0000	4	Clip, Retainer
12	21357.0000	4	Shaft, Wiper
13	26436.0000	1	Rod, Agitator Support
14	26449.0000	1	Spring
15	26441.0000	4	Wire, Agitator
16	21358.0000	1	Clip, Retainer
17	21365.0000	1	Washer, .31" I.D. x .56" O.D.
18	20960.0000	2	Shoulder Screw
	00991.0002	2	Nut, Elastic Lock #6-32
19	28945.0000	1	Panel, Hopper Support
	29934.1000	1	Panel, Hopper Support (Models with Hopper Guides)
	01311.0000	4	Screw, Truss Head #8-32 x .25"
20	25794.0001	2	Bracket, Motor Mounting
	01311.0001	8	Screw, Truss Head #8-32 x .25" Locking
21	29642.1001	2	Gearmotor W/Pin, Auger 120V (Includes item 20 & 23)
	01311.0000	8	Screw, Truss Head #8-32 x .25"
	01511.0000	2	Lockwasher, External Tooth #8
22	26401.0000	2	Dust Seal, Hopper Motor
23	26247.0000	2	Pin, Spring .094" Dia. x 1.0"
	26247.1000	-	Kit, Spring Pin (Includes 6 Pins)
24	-----	1	Panel, Motor Mounting (Early Models. Not available, order late model bracket)
	28946.0001	1	Panel, Motor Mounting (Late Models)
	01311.0001	2	Screw, Truss Head - Locking #8-32 x .25"
	00619.0009	2	Plug, Hole .688" Dia. (Early Models only)
25	29712.0000	1	Bracket, Hopper Locator
26	29575.0000	1	Panel, Dispense Valve Access (Late Models only)
	01311.0000	2	Screw, Truss Head #8-32 x .25"
27	11685.0000	1	Brush, Hopper Cleaning (Not Illustrated)
28	32394.0000	-	Kit, Auger Drive Shaft (Converts early models Drive Shaft to late model Drive Shaft)

* Indicates the part number listed is for reference only. See DESCRIPTION for possible service replacement.

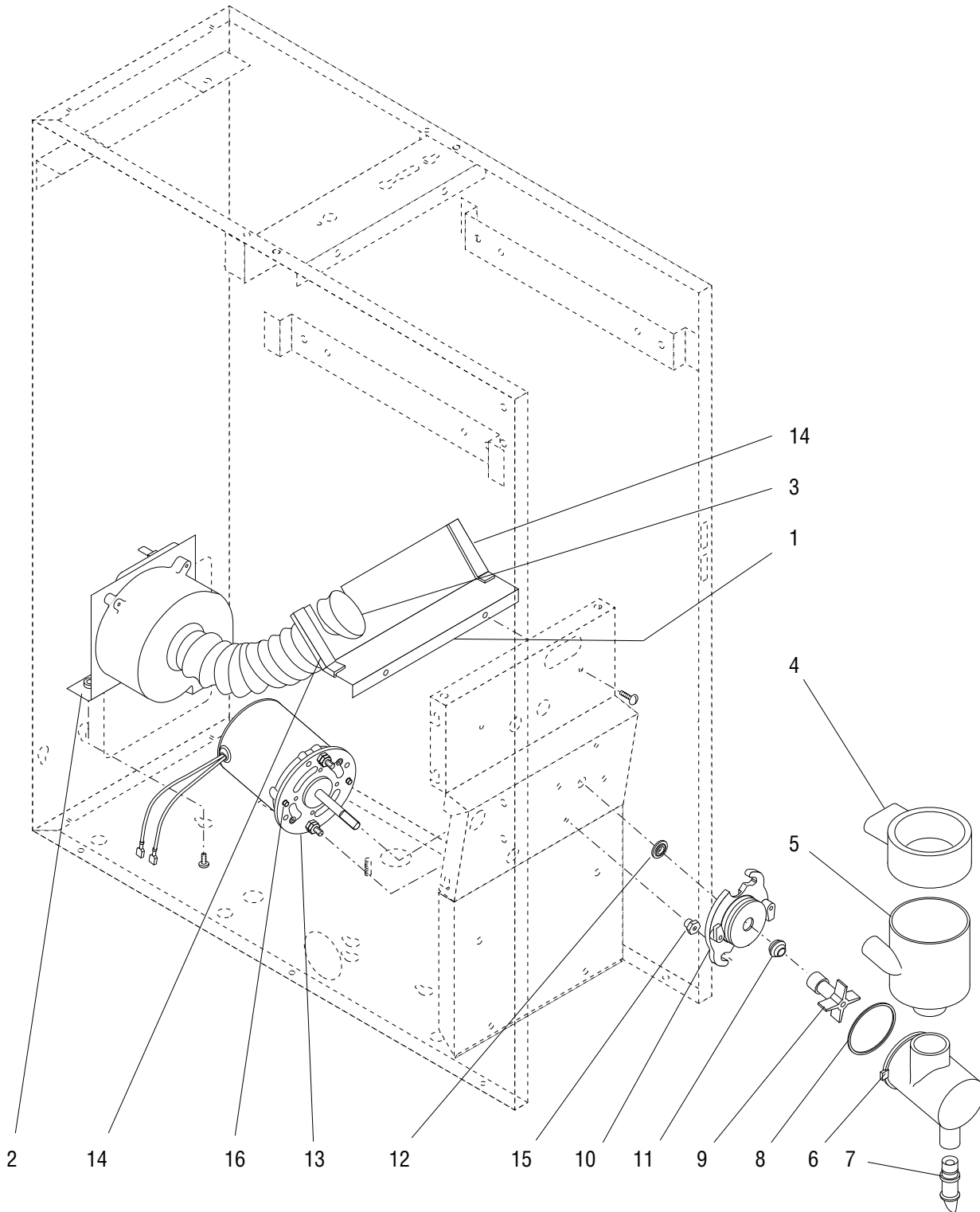

MIXING/WHIPPER CHAMBERS AND DRIVE MOTOR

ITEM	PART NO.	QTY.	DESCRIPTION
			*FMD-1
			**FMD-2
		* **	
1	29178.0000	1 -	Baffle Assembly, Fan (Includes item 14) (FMD-1) (Shown)
	29178.0001	- 1	Baffle Assembly, Fan (Includes item 14) (FMD-2)
	02336.0000	2 2	Screw, Truss Head #4-40 x .25"
2	28295.0000	1 1	Fan & Bracket Assembly (120V)
	28295.0001	1 1	Fan & Bracket Assembly (230V)
	01311.0001	2 2	Screw, Truss Head - Locking #8-32 x .25"
3	28297.0001	1 1	Hose, Vacuum
4	25732.0000	1 2	Steam Collector
5	25733.0000	1 2	Mixing Chamber
6	25734.1000	1 2	Whipper Chamber
7	25736.0000	1 2	Dispense Tip - Drink
	28864.0000	1 2	Dispense Tip - Soup
8	24733.0010	1 2	O-Ring
9	25902.0000	1 2	Frother
10	28866.0000	1 2	Receptacle, Whipper Chamber
11	26356.0000	1 2	Seal, Shaft
	26356.1000	- -	Kit, Shaft Seal (Includes 6 Seals)
12	28867.0000	1 2	Slinger
13	28428.1000	1 2	Motor, Whipper 120V (Includes item 16)
	28428.1002	1 2	Motor, Whipper 230V (Includes item 16)
14	-----	2 2	Gasket, Silicone 2.25" LG (Order item 17)
15	28865.0000	2 4	Nut
16	32306.0000	2 4	Spacer
17	02434.1000	- -	Gasket, Silicone 18" LG
18	32906.0000	- -	Kit, Preventive Maintenance (Includes items 4 thru 11 and 25903.0000 Elbow)

* Indicates the part number listed is for reference only. See DESCRIPTION for possible service replacement.

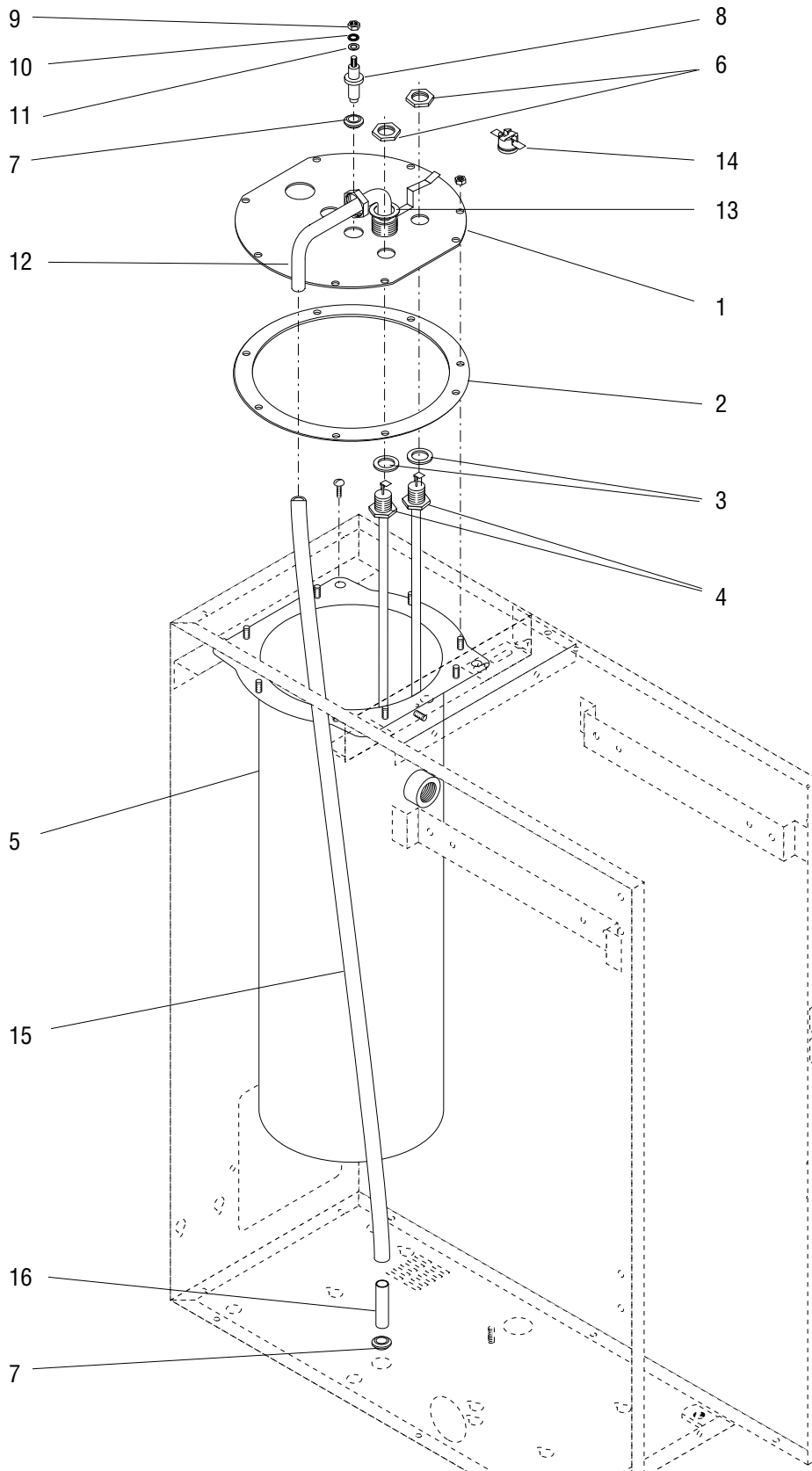

TANK, HEATER AND OVERFLOW PROTECTION

ITEM	PART NO.	QTY.	DESCRIPTION
1	28971.0000	1	Lid, Tank
	00908.0000	8	Nut, Hex #8 - 32
2	04221.0000	1	Gasket, Tank Lid
3	00943.0000	2	Gasket, Tank Heater
4	02534.1000	1	Tank Heater Kit, 1700W 120V (Includes item 3)
	02494.1000	1	Tank Heater Kit, 1700W 230V (Includes item 3)
5	02515.0001	1	Tank (FMD-1)
	02515.0002	1	Tank (FMD-2)
	01311.0000	4	Screw, Truss Head #8 - 32 x .375"
6	00942.0000	2	Nut, Hex .50" - 20
7	02536.0000	2	Grommet, .375" I.D.
8	07412.1002	1	Probe Kit (Includes items 9, 10 & 11)
9	00908.0000	1	Nut, Hex #8 - 32
10	20203.0100	1	Lockwasher, Internal Tooth #8
11	01501.0000	1	Washer, Flat .16" I.D. x .375" O.D.
12	28973.0000	1	Tube Assy, Overflow
	00957.0000	1	Nut, Hex .750"-16
13	01201.0000	1	Gasket
14	29329.1000	1	Thermostat, Limit
15	28526.0009*	1	Tube, Silicone .312" I.D. x .438" O.D. x 24.0" LG (Order item 17)
16	21801.0015	1	Tube, .375" O.D. x 1.50"
17	28526.1001	-	Tube, Silicone .312" I.D. x .438" O.D. x 36"
	28526.1002	-	Tube, Silicone .312" I.D. x .438" O.D. x 60"
	28526.1003	-	Tube, Silicone .312" I.D. x .438" O.D. x 120"

} Not Illustrated

* Indicates the part number listed is for reference only. See DESCRIPTION for possible service replacement.

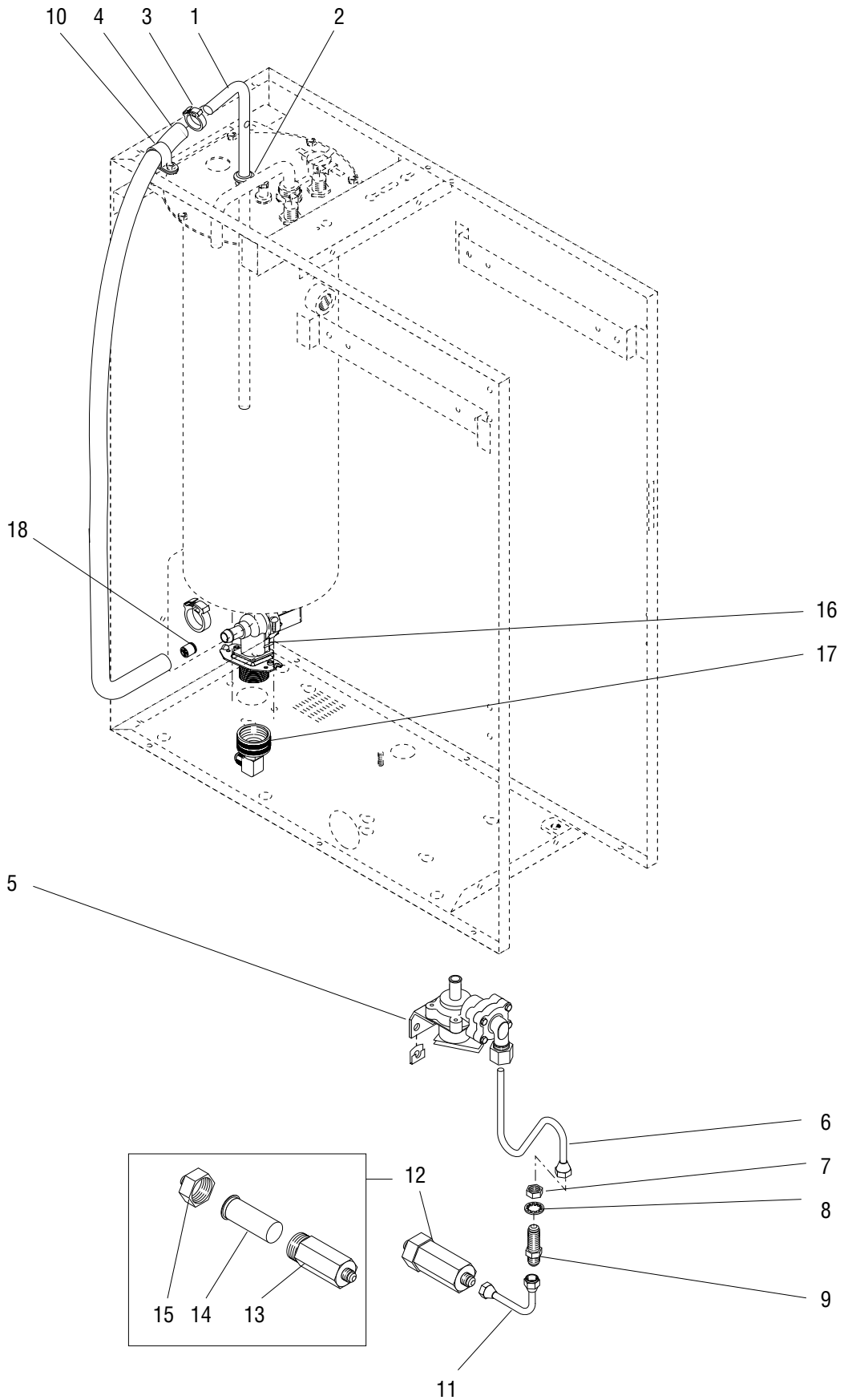

FILL VALVE AND LINES

ITEM	PART NO.	QTY.	DESCRIPTION
1	28298.0000	1	Tube, Tank Fill
2	02536.0000	1	Grommet, .375" I.D.
3	12422.0001	2	Clamp, Hose .59"/.66" I.D. (One less used on Late Models)
	12422.0005	1	Clamp, Hose .62"/.71" I.D. (Late Models)
4	28526.0009*	1	Tube, Silicone .312" I.D. x .438" O.D. x 24.0" (Order item 19)(Early Models)
	20976.0069*	1	Tube, Silicone .312" I.D. x .438" O.D. x 24.0" (Order item 21)(Late Models)
5	26135.1001	1	Valve Assy, Solenoid 120V (Serviced only as an assembly)(See Item 20)
	26135.0002	1	Valve Assy, Solenoid 230V (Serviced only as an assembly)(See Item 20)
	02322.0002	2	Screw, Truss Head #8-32 x .375" BLK
	00938.0000	2	Fastener, U-Type #8-32
6	26661.0000	1	Tube Assy, Water Inlet
7	00463.0000	1	Nut, Hex .438" - 20
8	01532.0000	1	Lockwasher, Internal Tooth .438"
9	00459.0000	1	Fitting, Bulkhead
10	00620.0000	1	Clamp, Hose
11	21814.0016	1	Tube Assy, Strainer To Bulkhead Fitting
12	23820.1000	1	Water Strainer Assy (Includes items 13 thru 15)
13	-----	1	Body (Not available. Order item 12)
14	23721.0000	1	Screen
15	22249.0000	1	End Cap
16	40506.0002	1	Valve, Inlet Solenoid 120V (Late Models)
	32283.0000	2	Screw, Pan Head M4 x 6mm
17	37297.0006	1	Elbow (Late Models)
18	36378.0001	1	Check Valve 2.5psi (Late Models)
19	28526.1001	-	Tube, Silicone .312" I.D. x .438" O.D. x 36"
	28526.1002	-	Tube, Silicone .312" I.D. x .438" O.D. x 60"
	28526.1003	-	Tube, Silicone .312" I.D. x .438" O.D. x 120"
20	26131.0000	-	Kit, Nut/O-Ring (Includes nut, spacer, grab ring, washer & 2 O-Rings)
21	20976.1000	-	Tube, Silicone .38" ID x 12.0" (Use as required)
	20976.1001	-	Tube, Silicone .38" ID x 36.0" (Use as required)
	20976.1002	-	Tube, Silicone .38" ID x 120.0" (Use as required)

* Indicates the part number listed is for reference only. See DESCRIPTION for possible service replacement.

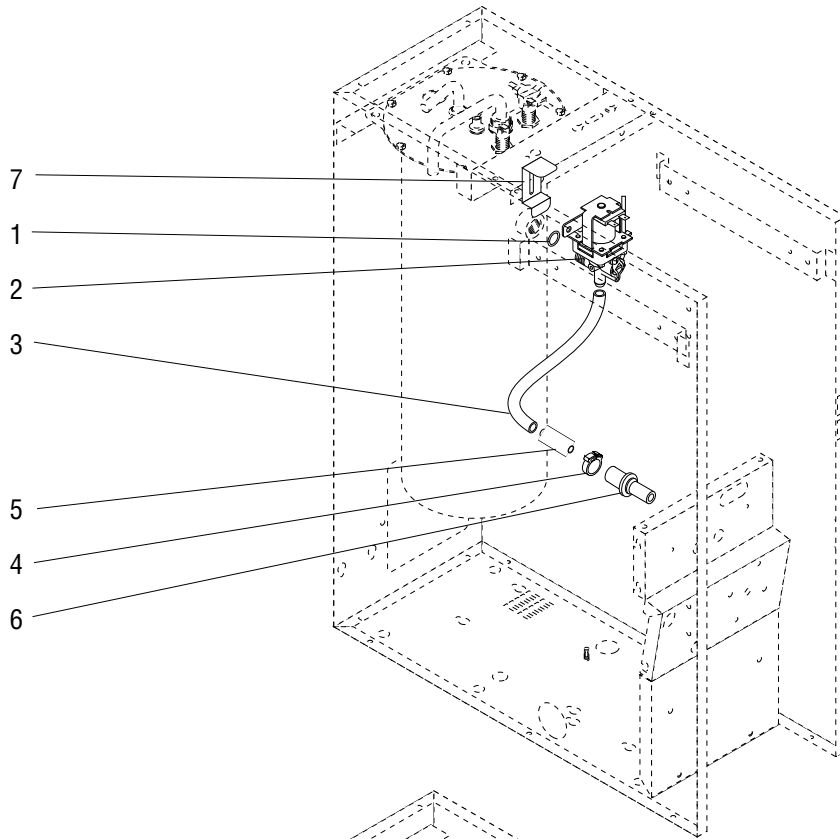

FMD-1

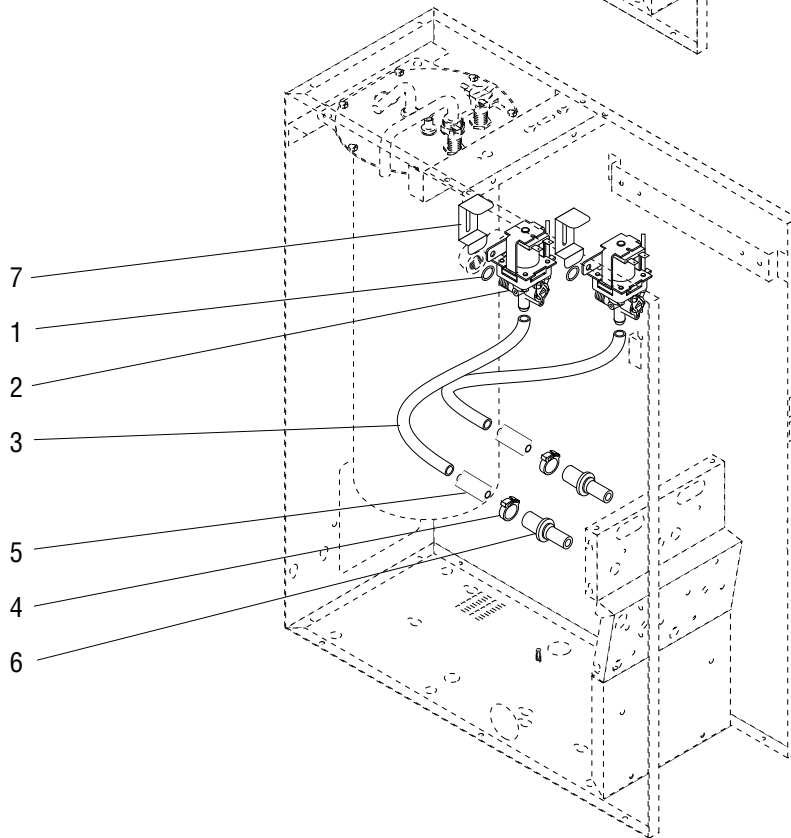

FMD-2

DISPENSE VALVE AND LINES

ITEM	PART NO.	QTY.	DESCRIPTION
			*FMD-1 **FMD-2
		* **	
1	24733.0011	1 2	O-Ring
2	39285.1001	1 2	Valve, Liquid Dispense 120V (Includes item 1)
	39285.1002	1 2	Valve, Liquid Dispense 230V (Includes item 1)
	01326.0000	1 2	Screw, Truss Head #10 - 32 x .250" (Early Models)
3	28526.0006*	1 2	Tube, Silicone .312" I.D. x .438" O.D. x 13.5" (Order item 8)
4	12422.0001	1 2	Clamp, Hose .59"/.66" I.D.
5	21801.0015	1 2	Tube, .375" O.D. x 1.50"
6	25803.0000	1 2	Water Inlet, Mixing Chamber
7	29576.0000	1 2	Bracket
	00970.0000	1 2	Nut, Keps #8-32
8	28526.1001	- -	Tube, Silicone .312" I.D. x .438" O.D. x 36"
	28526.1002	- -	Tube, Silicone .312" I.D. x .438" O.D. x 60"
	28526.1003	- -	Tube, Silicone .312" I.D. x .438" O.D. x 120"
9	45964.1000	1 2	Repair Kit, Dispense Valve

] Not
Illustrated

* Indicates the part number listed is for reference only. See DESCRIPTION for possible service replacement.

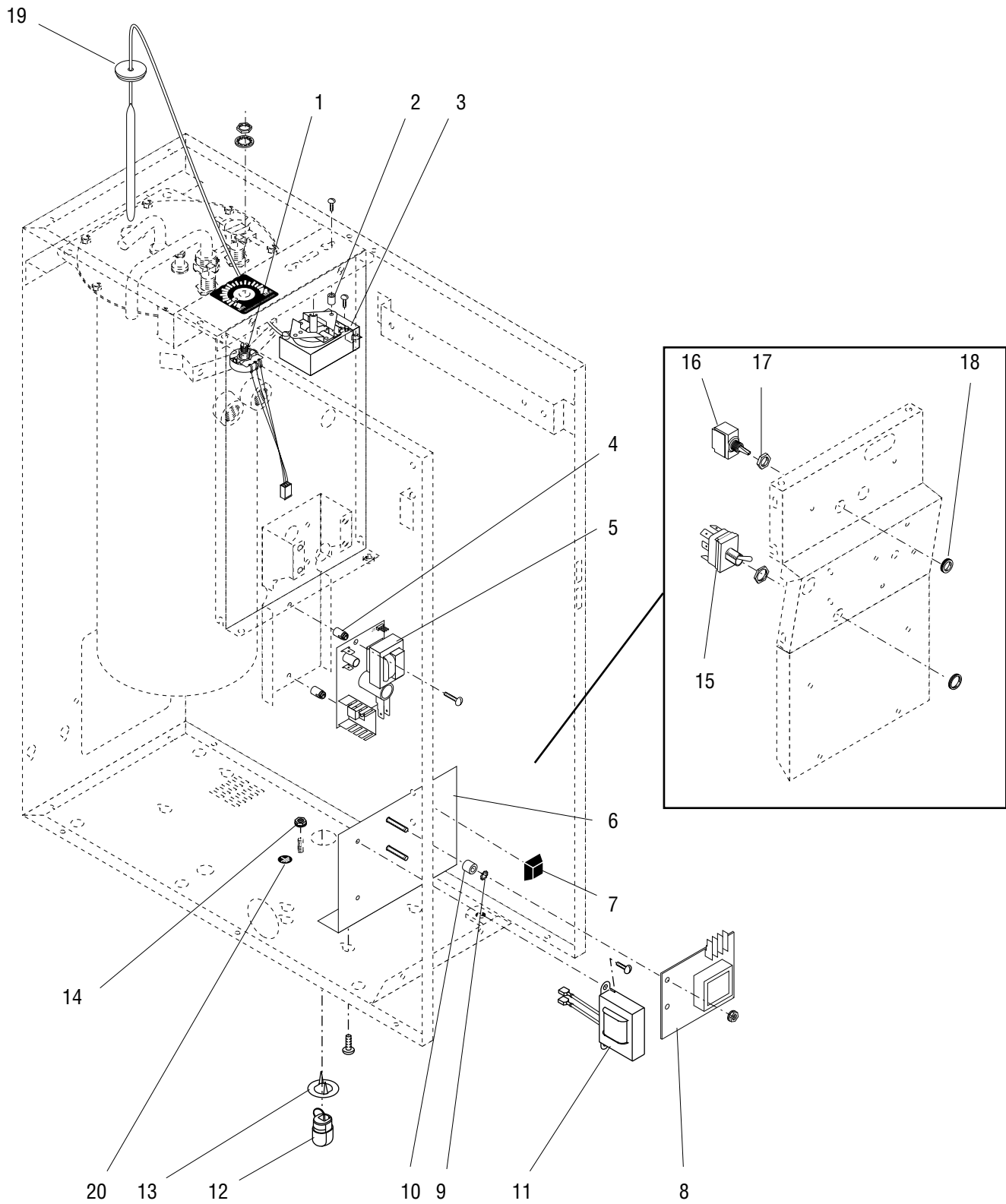

ELECTRICAL CONTROLS - FMD-1

ITEM	PART NO.	QTY.	DESCRIPTION
1	29110.0000	1	Potentiometer Assembly (Includes nut & lockwasher)
2	01533.0003	2	Spacer, .140" I.D. x .250" O.D. x .312" LG
3	40791.1007	1	Thermostat Assembly 120V
	02367.0002	2	Screw, Pan Head #6-32 x .625" (Mounting)
	20762.0000	2	Screw, Binding Head #8-32 x .25" (Terminal)
4	29081.0000	2	Spacer
5	29061.1000	1	PCB Assembly, Speed Control 120V
	29061.1001	1	PCB Assembly, Speed Control 230V
	38960.1000	1	PCB Assembly, Speed Control 230V (RoHS Compliant)
	02302.0000	2	Screw, Truss Head #6-32 x .88"
6	28986.0000	1	Bracket, Component Mounting
	01311.0001	2	Screw, Truss Head - Locking #8-32 x .25"
7	02547.0000	1	Foot, Rubber
8	07074.1030	1	Control Board, Level - 120V 5 SEC
	07074.1029	1	Control Board, Level - 230V 5 SEC
	00970.0000	2	Nut, Keps #8 - 32
9	01511.0000	2	Lockwasher, External Tooth #8
10	00450.0000	2	Spacer, .219" I.D. x .34" LG - Brass
11	28327.0000	1	Ballast, 120V-60Hz w/Terminals
	39642.0000	1	Ballast, 230V-50Hz w/Terminals
	02308.0000	2	Screw, Pan Head - Serrated #8-32 x .375"
12	00713.0000	1	Bushing, Strain Relief
13	00715.0000	1	Adapter Washer, Strain Relief
14	00970.0000	1	Nut, Keps #8-32 - Power Cord Ground
15	02686.0000	1	Switch, Toggle ON/OFF (Includes mounting nuts)
16	23522.1000	1	Switch, Toggle ON/OFF-Tank Heater (Includes item 17, also order item 18)
17	23696.0000	1	Nut, Hex .469" - 32
18	23697.0000	1	Nut, Plastic Face .469" - 32
19	07073.1000	1	Grommet
20	00824.0002	1	Decal, Grounding 230V

The following items are not illustrated

21	20630.0008	1	Cord Assembly, Power 120V
	27728.0002	1	Cord Assembly, Power 230V
22	28989.0000	1	Wiring Harness, Control - 120V
	28989.0001	1	Wiring Harness, Control - 230V
23	-----	1	Wiring Harness, Door (See Door, Lamps and Panels)

* Indicates the part number listed is for reference only. See DESCRIPTION for possible service replacement.

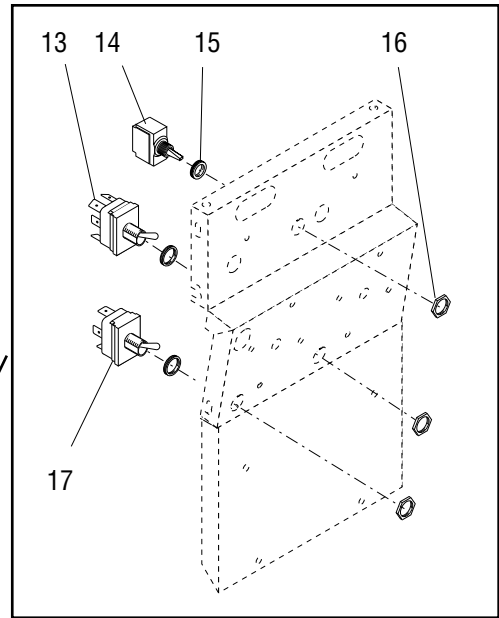
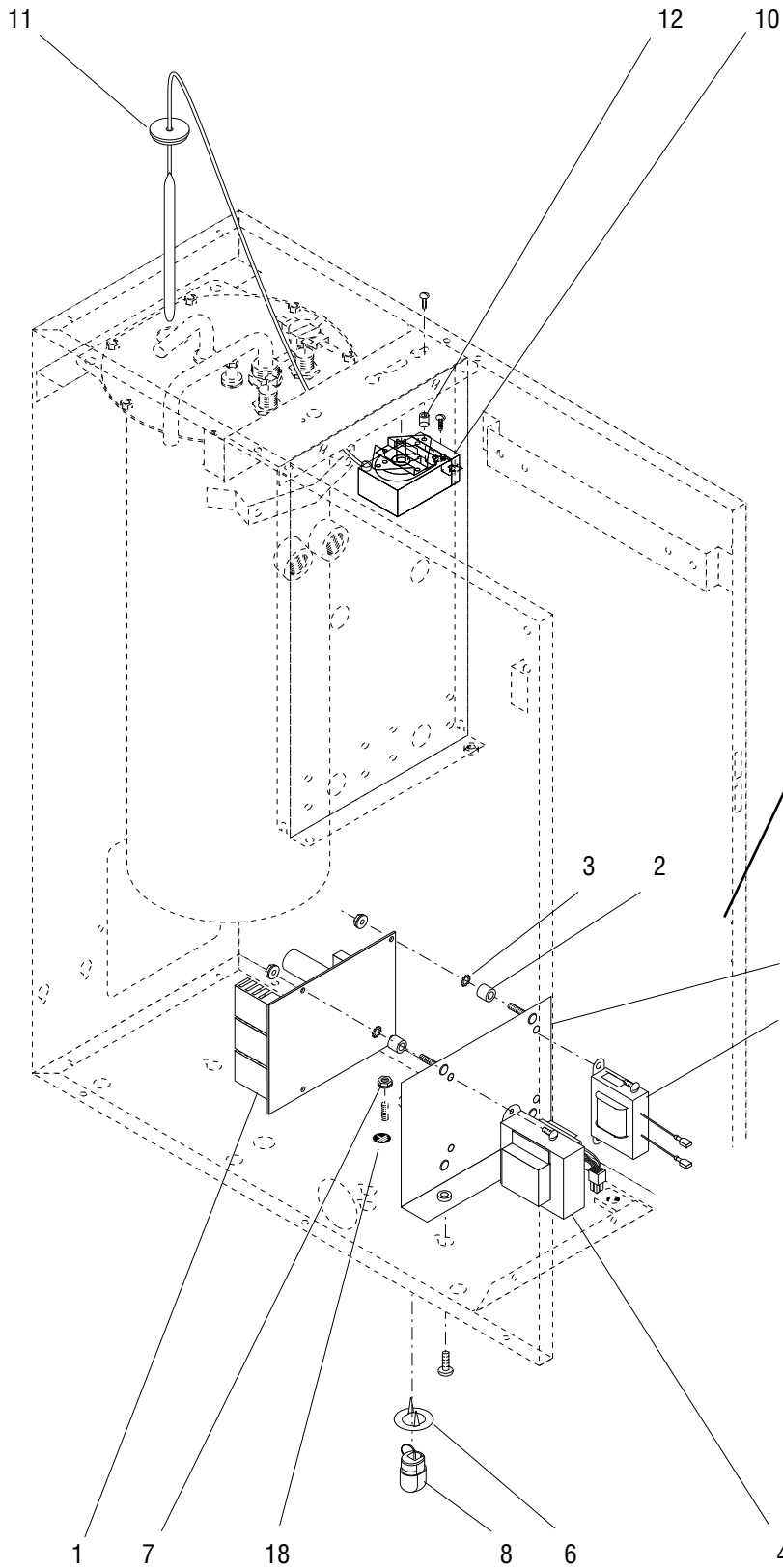

ELECTRICAL CONTROLS - FMD-2

ITEM	PART NO.	QTY.	DESCRIPTION
1	42996.0000	1	Control Board, 120V
	00973.0000	4	Nut, Keps #6-32
2	00450.0000	4	Spacer, .219" I.D. x .34" LG - Brass
3	01510.0000	4	Lockwasher, External Tooth #6
4	29124.0000	1	Transformer Assy, 120/24V, 25VA
	29124.0001	1	Transformer Assy, 230/24V, 25VA
	00973.0000	2	Nut, Keps #6-32 (Early models)
	01311.0001	2	Screw, Truss Head - Locking #8-32 x .25" (Late models)
5	29018.0004	1	Bracket, Component Mounting
	01311.0001	2	Screw, Truss Head - Locking #8-32 x .25"
6	00715.0000	1	Adapter Washer, Strain Relief
7	00970.0000	1	Nut, Keps #8-32 - Power Cord Ground
8	00713.0000	1	Bushing, Strain Relief
9	28327.0000	1	Ballast, 120V-60Hz w/Terminals
	39642.0000	1	Ballast, 230V-50Hz w/Terminals
	02308.0000	2	Screw, Pan Head - Serrated #8-32 x .375"
10	40791.1007	1	Thermostat Assembly 120V
	02367.0002	2	Screw, Truss Head #6-32 x .625" (Mounting)
	20762.0000	2	Screw, Binding Head #8-32 x .25" (Terminal)
11	07073.1000	1	Grommet
12	01533.0003	2	Spacer, .140" I.D. x .250" O.D. x .312" LG
13	28857.1000	1	Switch, Toggle RUN/RINSE/PROGRAM (Includes mounting nut, also order item 16)
14	23522.1000	1	Switch, Toggle ON/OFF-Tank Heater (Includes item 15, also order item 16)
15	23696.0000	1	Nut, Hex .469" - 32
16	23697.0000	1	Nut, Plastic Face .469" - 32
17	29122.0000	1	Switch, Toggle - INCREASE/DECREASE
18	00824.0002	1	Decal, Grounding 230V
The following items are not illustrated			
19	20630.0008	1	Cord Assembly, Power 120V
	27728.0002	1	Cord Assembly, Power 230V
20	29118.0000	1	Wiring Harness, Control - 120V
	29118.0001	1	Wiring Harness, Control - 230V
21	-----	1	Wiring Harness, Door (See Door, Lamps and Panels)
22	28862.0000	1	Lead Assembly, Jumper (Dispensers W/Out Cold Water Valve)

* Indicates the part number listed is for reference only. See DESCRIPTION for possible service replacement.

NUMERICAL INDEX

PART NO.	PAGE NO.	PART NO.	PAGE NO.	PART NO.	PAGE NO.	PART NO.	PAGE NO.
00450.0000	25,27	12422.0005	21	26401.0000	13,15	28833.0000	11
00459.0000	21	12517.0001	9	26435.0000	15	28833.0001	11
00463.0000	21	13255.0003	7	26435.0001	15	28857.1000	27
00619.0009	13,15	20203.0100	19	26436.0000	15	28862.0000	27
00620.0000	21	20377.0001	13	26441.0000	15	28864.0000	17
00656.0001	7	20630.0008	25,27	26444.0000	9	28865.0000	17
00713.0000	25,27	20762.0000	25,27	26449.0000	15	28866.0000	17
00715.0000	25,27	20960.0000	15	26504.0000	7	28867.0000	17
00824.0002	25,27	20976.0069	21	26523.0000	5	28872.0000	7
00831.0000	7	20976.1000	21	26524.0000	5	28910.0000	7
00908.0000	19	20976.1001	21	26528.0000	5	28937.0000	5
00938.0000	21	20976.1002	21	26537.0000	11	28937.0001	5
00942.0000	19	21004.0338	11	26537.0001	11	28941.0001	5
00943.0000	19	21355.0000	13	26537.0003	11	28942.0000	13
00957.0000	19	21355.0001	15	27543.1005	9	28945.0000	15
00970.0000	9,23,25,27	21357.0000	13,15	27543.1006	9	28946.0000	13
00973.0000	27	21358.0000	13,15	26661.0000	21	28946.0001	15
00991.0000	5	21365.0000	15	26892.0000	9	28952.0001	5
00991.0002	15	21436.0000	7	26940.0002	15	28954.0001	5
01201.0000	19	21465.0001	13	26940.0003	13	28960.0001	9
01308.0000	9	21746.0000	13	27096.0000	7	28962.0000	9
01311.0000	5,9,13,15,19	21747.0001	13	27298.0500	9	28963.0000	9
01311.0001	5,7,13	21801.0015	19,23	27619.0000	9	28964.0000	9
01311.0001	15,17,25,27	21814.0016	21	27728.0002	25,27	28964.0001	9
01311.0003	5	22249.0000	21	28061.0000	15	28966.0000	5
01326.0000	23	23164.0002	5	28067.0000	15	28971.0000	19
01501.0000	19	23279.0000	9	28295.0000	17	28973.0000	19
01510.0000	27	23522.1000	25,27	28295.0001	17	28986.0000	25
01511.0000	15,25	23696.0000	25,27	28296.1000	9	28989.0000	25
01522.0000	13	23697.0000	25,27	28297.0001	17	28989.0001	25
01532.0000	21	23721.0000	21	28298.0000	21	28990.0000	9
01533.0003	25,27	23820.1000	21	28322.0000	9	29014.1000	13
02302.0000	25	24733.0010	17	28325.0000	9	29018.0004	27
02308.0000	5,25,27	24733.0011	23	28327.0000	25,27	29027.0000	5
02322.0002	5,7,21	25292.0000	9	28328.0004	5	29027.0001	5
02328.0002	9	25732.0000	17	28328.0005	5	29061.1000	25
02336.0000	17	25733.0000	17	28335.0000	9	29061.1001	25
02367.0002	25,27	25734.1000	17	28336.0000	11	29081.0000	25
02434.1000	17	25736.0000	17	28366.1000	7	29096.0000	7
02494.1000	19	25743.0000	15	28366.1001	7,11	29096.0001	7
02515.0001	19	25794.0001	15	28366.1002	7,11	29106.0000	9
02515.0002	19	25794.0002	13	28368.0001	5	29106.0001	9
02534.1000	19	25803.0000	23	28368.0003	5	29110.0000	25
02536.0000	19,21	25892.0000	13	28424.1000	15	29118.0000	27
02547.0000	25	25902.0000	17	28424.1002	15	29118.0001	27
02571.0000	5	25903.0000	13,15	28425.0000	15	29119.0000	9
02686.0000	25	26112.0001	15	28428.1000	17	29122.0000	27
03996.0000	5	26131.0000	21	28428.1002	17	29124.0000	27
04221.0000	19	26135.1001	21	28526.0006	23	29124.0001	27
07073.1000	25,27	26135.0002	21	28526.0009	19,21	29161.0000	9
07074.1029	25	26239.0000	9	28526.1001	19,21,23	29161.0001	9
07074.1030	25	26247.0000	13,15	28526.1002	19,21,23	29172.0000	5
07412.1002	19	26247.1000	13,15	28526.1003	19,21,23	29173.0000	5
11685.0000	15	26356.0000	17	28679.0000	13	29173.0001	5
12422.0001	21,23	26356.1000	17	28698.0000	13	29174.0000	5

NUMERICAL INDEX

PART NO.	PAGE NO.	PART NO.	PAGE NO.	PART NO.	PAGE NO.	PART NO.	PAGE NO.
29174.0001.....	5						
29175.0000.....	9						
29175.0001.....	9						
29176.0000.....	9						
29176.0001.....	9						
29178.0000.....	17						
29178.0001.....	17						
29308.0000.....	9						
29329.1000.....	19						
29575.0000.....	13,15						
29576.0000.....	23						
29642.1000.....	13						
29642.1001.....	15						
29712.0000.....	15						
29934.1000.....	15						
29939.0001.....	5						
32283.0000.....	21						
32306.0000.....	17						
32337.0000.....	15						
32383.0000.....	13,15						
32386.0000.....	15						
32386.0001.....	15						
32394.0000.....	15						
32394.0001.....	13						
32906.0000.....	17						
34130.0000.....	9						
34972.0000.....	5						
36378.0001.....	21						
37297.0006.....	21						
37881.0000.....	7						
38960.1000.....	25						
39285.1001.....	23						
39285.1002.....	23						
39642.0000.....	25,27						
40506.0002.....	21						
40780.0000.....	9						
40782.0000.....	9						
40791.1007.....	25,27						
42996.0000.....	27						
45964.1000.....	23						