

# BUNN®

# IC3

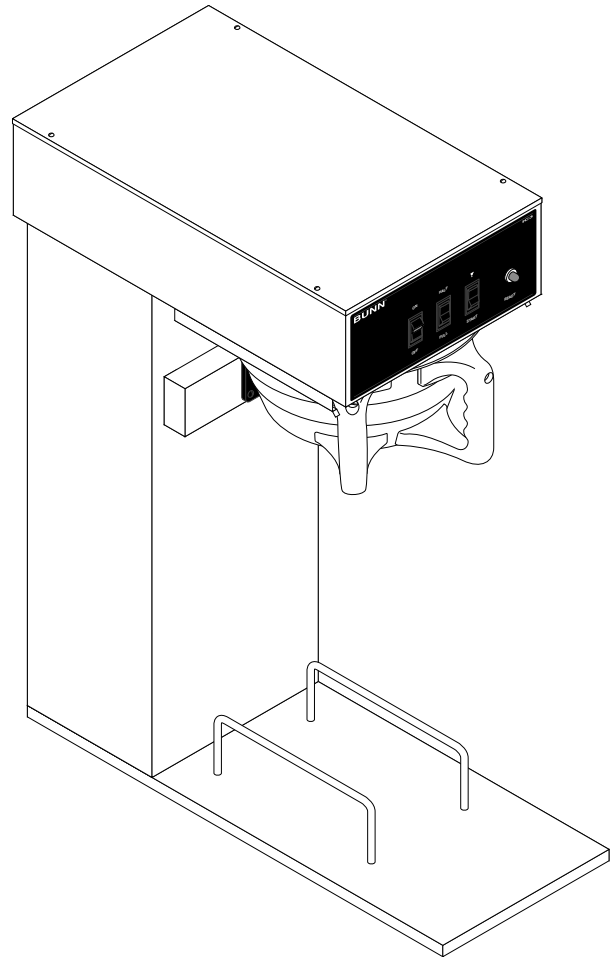
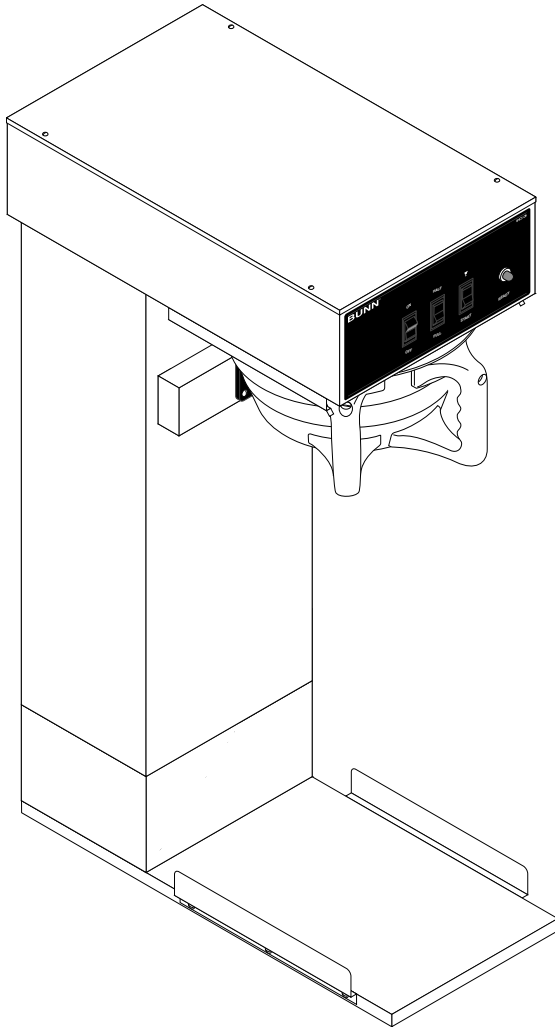

## ILLUSTRATED PARTS CATALOG

Designs, materials, weights, specifications, and dimensions for equipment or replacement parts are subject to change without notice.

**BUNN-O-MATIC CORPORATION**

POST OFFICE BOX 3227

SPRINGFIELD, ILLINOIS 62708-3227

PHONE: (217) 529-6601 FAX: (217) 529-6644

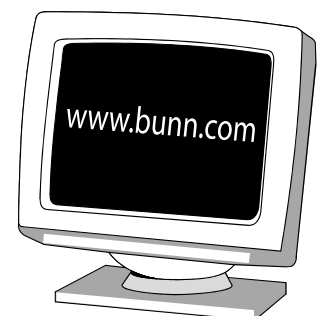

## **BUNN-O-MATIC COMMERCIAL PRODUCT WARRANTY**

Bunn-O-Matic Corp. ("BUNN") warrants equipment manufactured by it as follows:

- 1) Airpots, thermal carafes, decanters, GPR servers, iced tea/coffee dispensers, MCP/MCA pod brewers thermal servers and ThermoFresh servers (mechanical and digital)- 1 year parts and 1 year labor.
- 2) All other equipment - 2 years parts and 1 year labor plus added warranties as specified below:
  - a) Electronic circuit and/or control boards - parts and labor for 3 years.
  - b) Compressors on refrigeration equipment - 5 years parts and 1 year labor.
  - c) Grinding burrs on coffee grinding equipment to grind coffee to meet original factory screen sieve analysis - parts and labor for 4 years or 40,000 pounds of coffee, whichever comes first.

These warranty periods run from the date of installation BUNN warrants that the equipment manufactured by it will be commercially free of defects in material and workmanship existing at the time of manufacture and appearing within the applicable warranty period. This warranty does not apply to any equipment, component or part that was not manufactured by BUNN or that, in BUNN's judgment, has been affected by misuse, neglect, alteration, improper installation or operation, improper maintenance or repair, non periodic cleaning and descaling, equipment failures related to poor water quality, damage or casualty. In addition, the warranty does not apply to replacement of items subject to normal use including but not limited to user replaceable parts such as seals and gaskets. This warranty is conditioned on the Buyer 1) giving BUNN prompt notice of any claim to be made under this warranty by telephone at (217) 529-6601 or by writing to Post Office Box 3227, Springfield, Illinois 62708-3227; 2) if requested by BUNN, shipping the defective equipment prepaid to an authorized BUNN service location; and 3) receiving prior authorization from BUNN that the defective equipment is under warranty.

**THE FOREGOING WARRANTY IS EXCLUSIVE AND IS IN LIEU OF ANY OTHER WARRANTY, WRITTEN OR ORAL, EXPRESS OR IMPLIED, INCLUDING, BUT NOT LIMITED TO, ANY IMPLIED WARRANTY OF EITHER MERCHANTABILITY OR FITNESS FOR A PARTICULAR PURPOSE.** The agents, dealers or employees of BUNN are not authorized to make modifications to this warranty or to make additional warranties that are binding on BUNN. Accordingly, statements by such individuals, whether oral or written, do not constitute warranties and should not be relied upon.

If BUNN determines in its sole discretion that the equipment does not conform to the warranty, BUNN, at its exclusive option while the equipment is under warranty, shall either 1) provide at no charge replacement parts and/or labor (during the applicable parts and labor warranty periods specified above) to repair the defective components, provided that this repair is done by a BUNN Authorized Service Representative; or 2) shall replace the equipment or refund the purchase price for the equipment.

**THE BUYER'S REMEDY AGAINST BUNN FOR THE BREACH OF ANY OBLIGATION ARISING OUT OF THE SALE OF THIS EQUIPMENT, WHETHER DERIVED FROM WARRANTY OR OTHERWISE, SHALL BE LIMITED, AT BUNN'S SOLE OPTION AS SPECIFIED HEREIN, TO REPAIR, REPLACEMENT OR REFUND.**

In no event shall BUNN be liable for any other damage or loss, including, but not limited to, lost profits, lost sales, loss of use of equipment, claims of Buyer's customers, cost of capital, cost of down time, cost of substitute equipment, facilities or services, or any other special, incidental or consequential damages.

392, AutoPOD, AXIOM, BrewLOGIC, BrewMETER, Brew Better Not Bitter, BrewWISE, BrewWIZARD, BUNN Espresso, BUNN Family Gourmet, BUNN Gourmet, BUNN Pour-O-Matic, BUNN, BUNN with the stylized red line, BUNNlink, Bunn-OMatic, Bunn-O-Matic, BUNNserve, BUNNSERVE with the stylized wrench design, Cool Froth, DBC, Dr. Brew stylized Dr. design, Dual, Easy Pour, EasyClear, EasyGard, FlavorGard, Gourmet Ice, Gourmet Juice, High Intensity, iMIX, Infusion Series, Intellisteam, My Café, Phase Brew, PowerLogic, Quality Beverage Equipment Worldwide, Respect Earth, Respect Earth with the stylized leaf and coffee cherry design, Safety-Fresh, savemycoffee.com, Scale-Pro, Silver Series, Single, Smart Funnel, Smart Hopper, SmartWAVE, Soft Heat, SplashGard, The Mark of Quality in Beverage Equipment Worldwide, ThermoFresh, Titan, trifecta, Velocity Brew, A Partner You Can Count On, Air Brew, Air Infusion, Beverage Bar Creator, Beverage Profit Calculator, Brew better, not bitter., BUNNSource, Coffee At Its Best, Cyclonic Heating System, Daypart, Digital Brewer Control, Nothing Brews Like a BUNN, Pouring Profits, Signature Series, Tea At Its Best, The Horizontal Red Line, Ultra are either trademarks or registered trademarks of Bunn-O-Matic Corporation.

## TABLE OF CONTENTS

Electrical and Operating Controls.....	12
Funnels .....	14
Numerical Index.....	16
Strainer, Flow Control, Solenoid & Lines.....	8
Tank Assembly .....	6
Top Cover, Hood, Trunk, Base & Panels .....	4

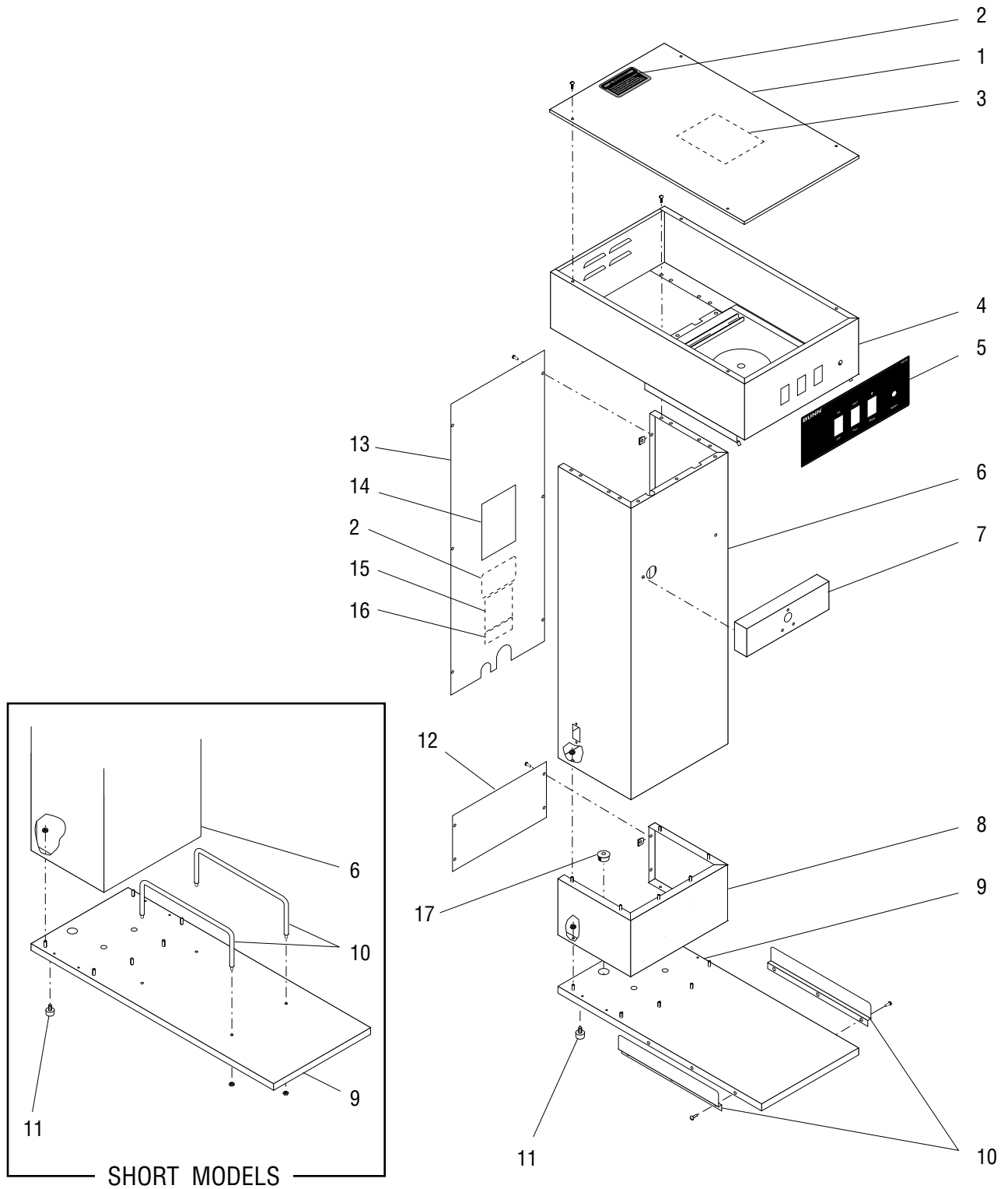

## TOP COVER, HOOD, TRUNK, BASE AND PANELS

ITEM	PART NO.	QTY.	DESCRIPTION
1	24435.1000	1	Cover W/Decals, Top (Includes items 2 & 3)
	01382.0000	4	Screw, Truss Head #6-32 x .375"
2	37881.0000	2	Decal, No Serviceable Parts
3	32540.0000	1	Decal, Batch Setting
4	24699.0000	1	Hood (Includes Item 5)
	02308.0000	7	Screw, Pan Head #8-32 x .375"
5	24447.0000	1	Decal, Hood - Control Panel
6	24441.0001	1	Trunk Assy
	00970.0000	6	Nut, Hex Keps #8-32
7	03773.0000	1	Housing, Nozzle Mounting
	00970.0000	2	Nut, Hex Keps #8-32
8	24444.0000	1	Housing Assy, Trunk Extension 5.0" (Tall Models only)
	00970.0000	6	Nut, Hex Keps #8-32
9	24431.0000	1	Base (Tall Models)
	24431.0001	1	Base (Short Models)
10	03772.0001	2	Guide, Server(Tall Models)
	01317.0003	6	Screw, Pan Head - Locking #8-32 x .375"
	12249.0008	2	Guide, Server (Short Models)
	00970.0000	4	Nut, Hex Keps #8-32
11	25137.0001	4	Foot, .75" O.D. x .44" (See item 18)
12	24427.0000	1	Cover, Trunk Extension (Tall Models only)
	01315.0000	4	Screw, Truss Head #8-32 x .375"
	00917.0000	4	Fastener, J-Type #8-32
13	24698.0000	1	Panel W/Decals, Access (Includes items 2, 14, 15 & 16)
	01315.0000	6	Screw, Truss Head #8-32 x .375"
	00917.0000	6	Fastener, J-Type #8-32
14	10793.0000	1	Schematic, Electrical
15	00831.0000	1	Decal, WARNING Electrical
16	00656.0001	1	Decal, Comply to Plubing Code
17	00668.0000	1	Plug, Hole, BLK .75" dia.
18	24600.0000	1	Kit, Foot (Includes 4 of item 11)

\* Indicates the part number listed is for reference only. See DESCRIPTION for possible service replacement.

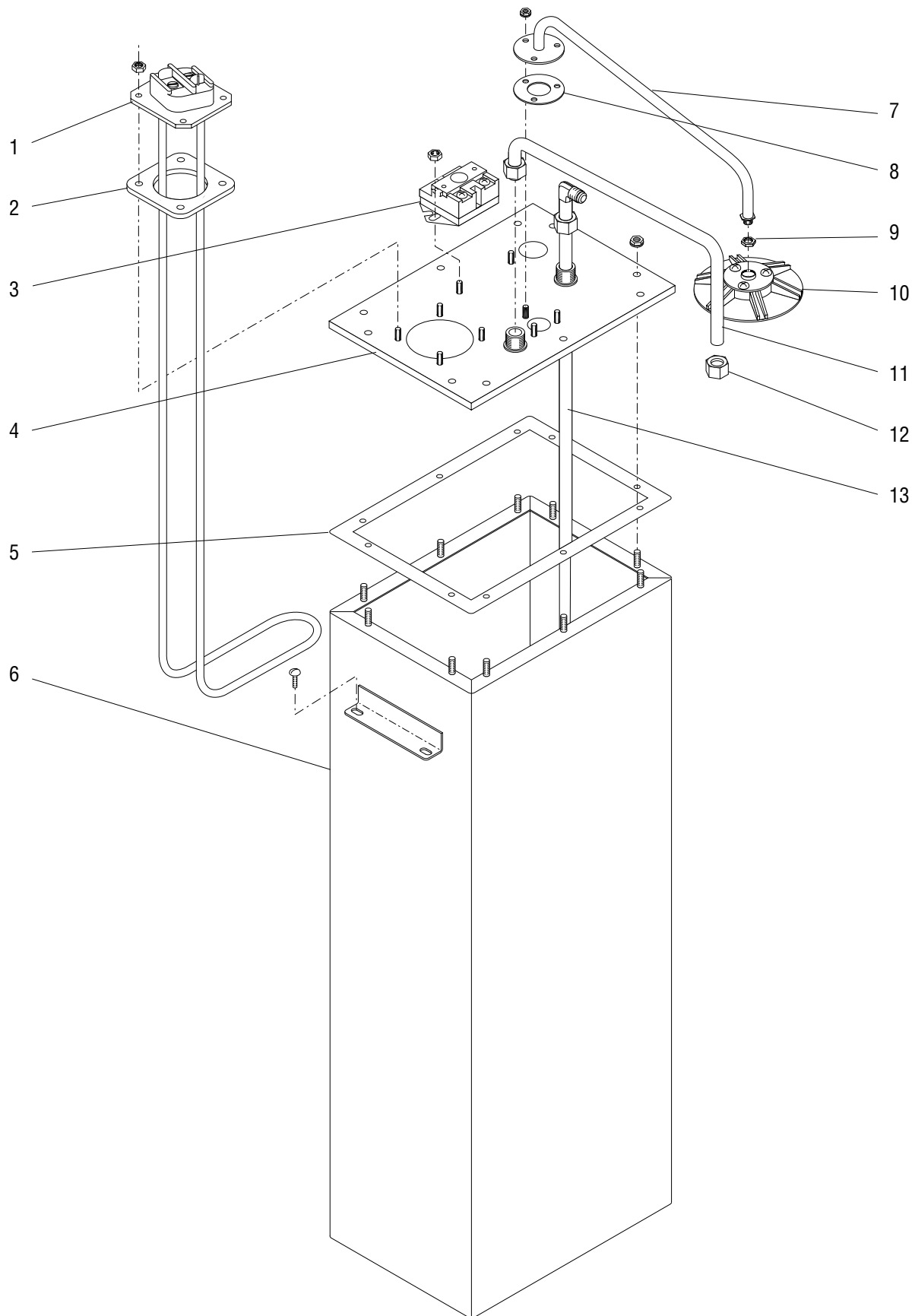

## TANK ASSEMBLY

ITEM	PART NO.	QTY.	DESCRIPTION
1	12305.1000	1	Tank Heater Kit, 120/208V (Includes item 2)
	12322.1000	1	Tank Heater Kit, 120/240V (Includes item 2)
	00908.0000	4	Nut, Hex #8-32
2	12398.0000	1	Gasket, Tank Heater
3	23717.0003	1	Limit Thermostat
	00971.0000	2	Nut, Keps #10-32
4	25926.0000	1	Tank Lid
	00906.0000	10	Nut, Hex #6-32
5	12377.0000	1	Gasket, Tank Lid
6	25920.0003	1	Tank
	02308.0000	4	Screw, Pan Head #8-32 x .375"
7	24637.0000	1	Tube, Sprayhead
	00908.0000	3	Nut, Hex #8-32
8	05515.0000	1	Gasket, Sprayhead Tube
9	01075.0000	1	Nut, Hex .438"-20
10	24527.0000	1	Sprayhead
11	24532.0000	1	Tube Assy, Vent (Includes item 12)
12	00929.0001	2	Nut/Sleeve Compression .375"
13	24531.0000	1	Tube, Fill

\* Indicates the part number listed is for reference only. See DESCRIPTION for possible service replacement.

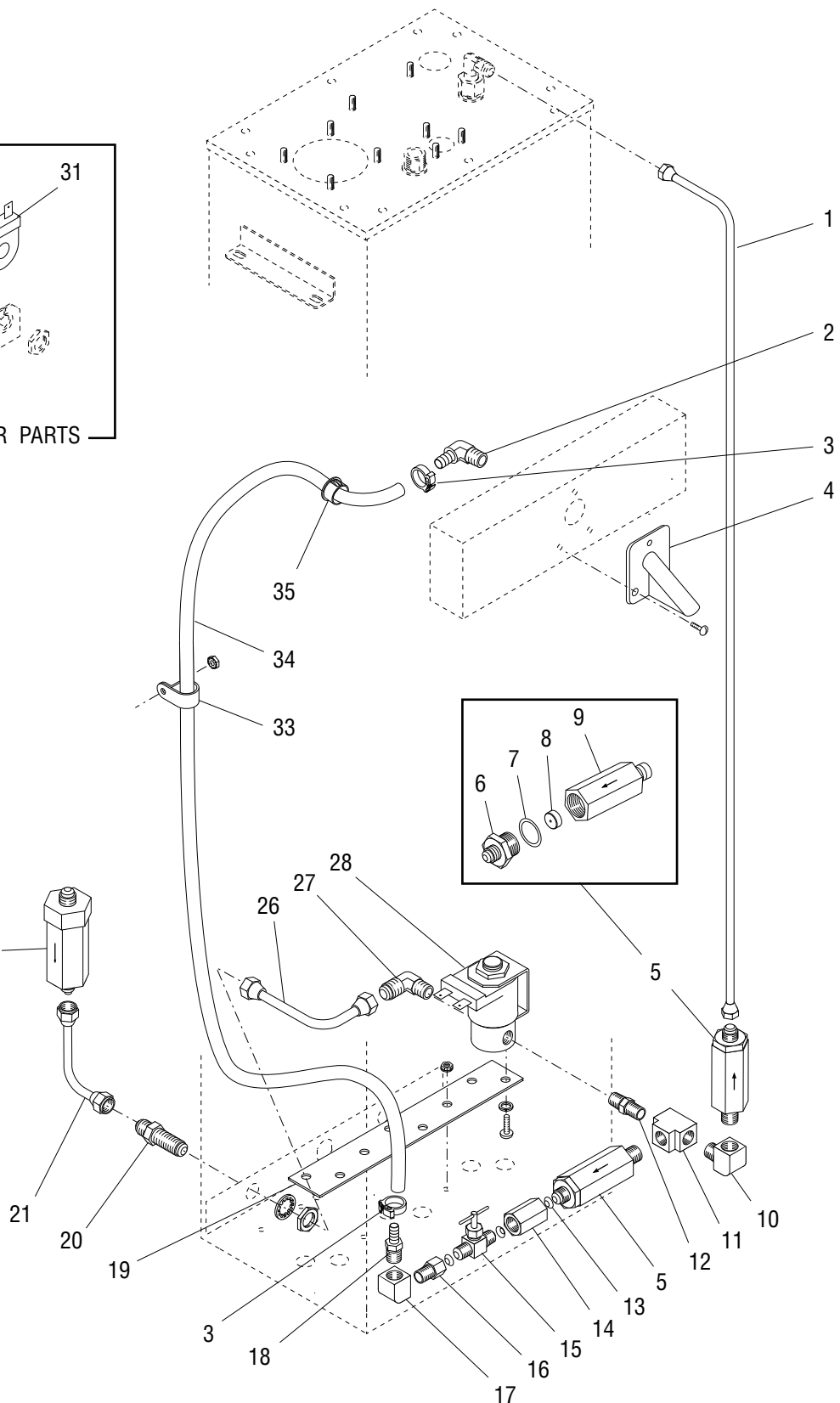
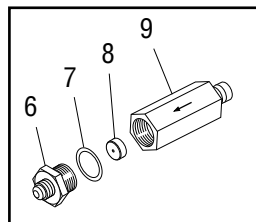
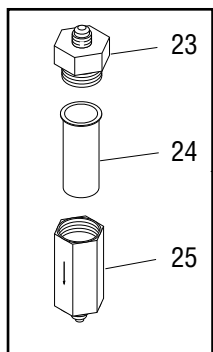
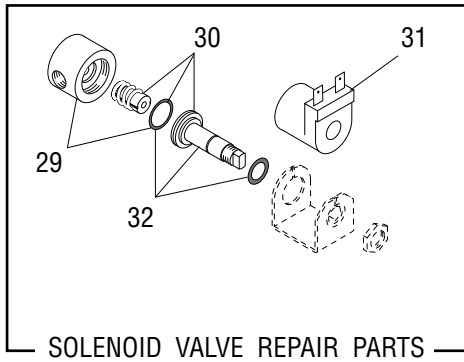



## STRAINER, FLOW CONTROL, SOLENOID & LINES

ITEM	PART NO.	QTY.	DESCRIPTION
1	24569.0000	1	Tube Assy, Flow Control to Tank
2	00464.0001	1	Elbow, .25" Barb x .125" MPT
3	12422.0000	2	Clamp, Hose .47"/.54" ID
4	03717.0000 01382.0002	1 3	Nozzle, Dilution Screw, Truss Head, BLK #6-32 x .375"
5	20528.1330	1	Flow Control Assy (Includes items 6 thru 9)
6	01154.0001	1	Fitting, Outlet
7	01155.0000	1	Gasket
8	20526.1330	1	Flow/Washer Gasket Kit (.330 GPM)(Includes item 7)
9	-----	1	Body (Not available. Order item 5)
10	00432.0001	1	Elbow, .125" NPT Male/Female
11	24599.0001	1	Tee, Union .125" FPT
12	00412.0001	1	Nipple, .125" NPT
13	24684.0000	3	Gasket, .25" Flare Copper
14	24614.1001	1	Union, .25" Flare
15	00484.0001	1	Valve, Needle .25" flare
16	24613.0001	1	Adapter, .25" x .125" MPT
17	00435.0001	1	Elbow, .125" NPT Female
18	22397.0001	1	Fitting, .25" Barb x .125" MPT
19	03170.0000 00970.0000	1 2	Plate, Mouting Nut, Keps #8-32
20	00459.0000 01532.0000 00463.0000	1 1 1	Fitting, Bulkhead Lockwasher, Internal Tooth .375" Nut, Hex .375"-20
21	00310.0000	1	Tube Assy
22	23820.1000	1	Strainer Assy (Includes items 23 thru 25)
23	22249.0000	1	Fitting Inlet
24	23721.0000	1	Screen
25	-----	1	Body (Not available. Order item 22)
26	00310.0005	1	Tube Assy
27	00400.0001	1	Elbow, Male .25" Flare x .125" MPT
28	01085.0002 01327.0000 01502.0000	1 2 2	Valve Assy, Solenoid 120V Screw, Pan Head #10-32 x .375" Lockwasher, Split #10

(continued)

\* Indicates the part number listed is for reference only. See DESCRIPTION for possible service replacement.

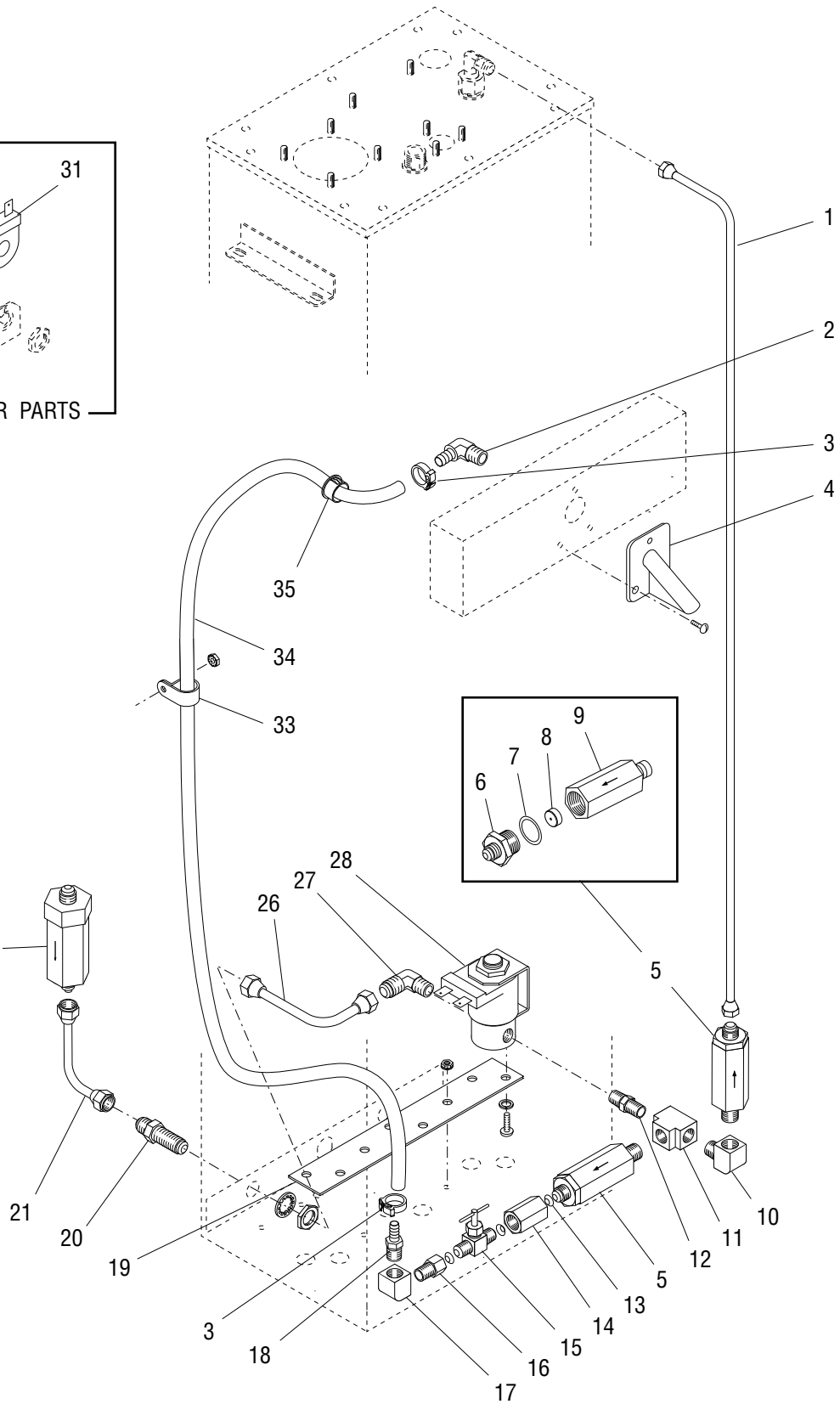
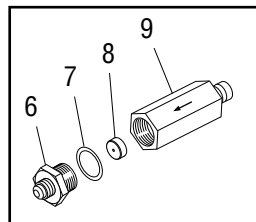
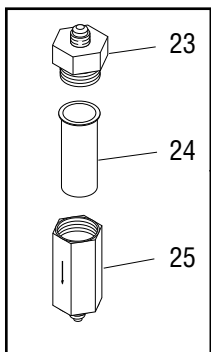
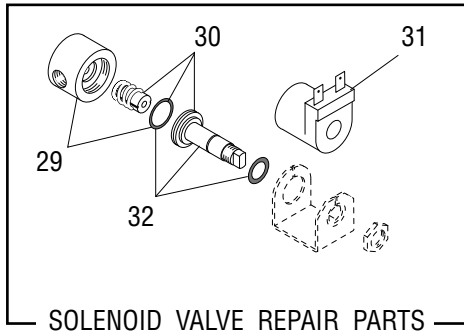

## STRAINER, FLOW CONTROL, SOLENOID & LINES

ITEM	PART NO.	QTY.	DESCRIPTION
29	28479.0000	1	Solenoid Valve Base Kit (Includes O-ring)
30	01111.0000	1	Solenoid Valve Repair Kit (Includes Plunger, Spring and O-ring)
31	28480.0000	1	Solenoid Valve Coil, 120V
32	28481.0000	1	Guide Kit (Includes Washer and O-ring)
33	00603.0000	1	Clamp, Hose.438" ID
	00970.0000	1	Nut, Keps #8-32
34	11707.0013*	1	Tube, Silicone .25" ID x 28.0" (Order item 36)(Tall Models)
	11707.0012*	1	Tube, Silicone .25" ID x 23.0" (Order item 36)(Short Models)
35	01592.0000	1	Bushing, 1.0" Dia. Hole
36	11707.1000	-	Tube .25" ID x 12.0" (Use as required)
	11707.1001	-	Tube .25" ID x 36.0" (Use as required)
	11707.1002	-	Tube .25" ID x 120.0" (Use as required)

\* Indicates the part number listed is for reference only. See DESCRIPTION for possible service replacement.

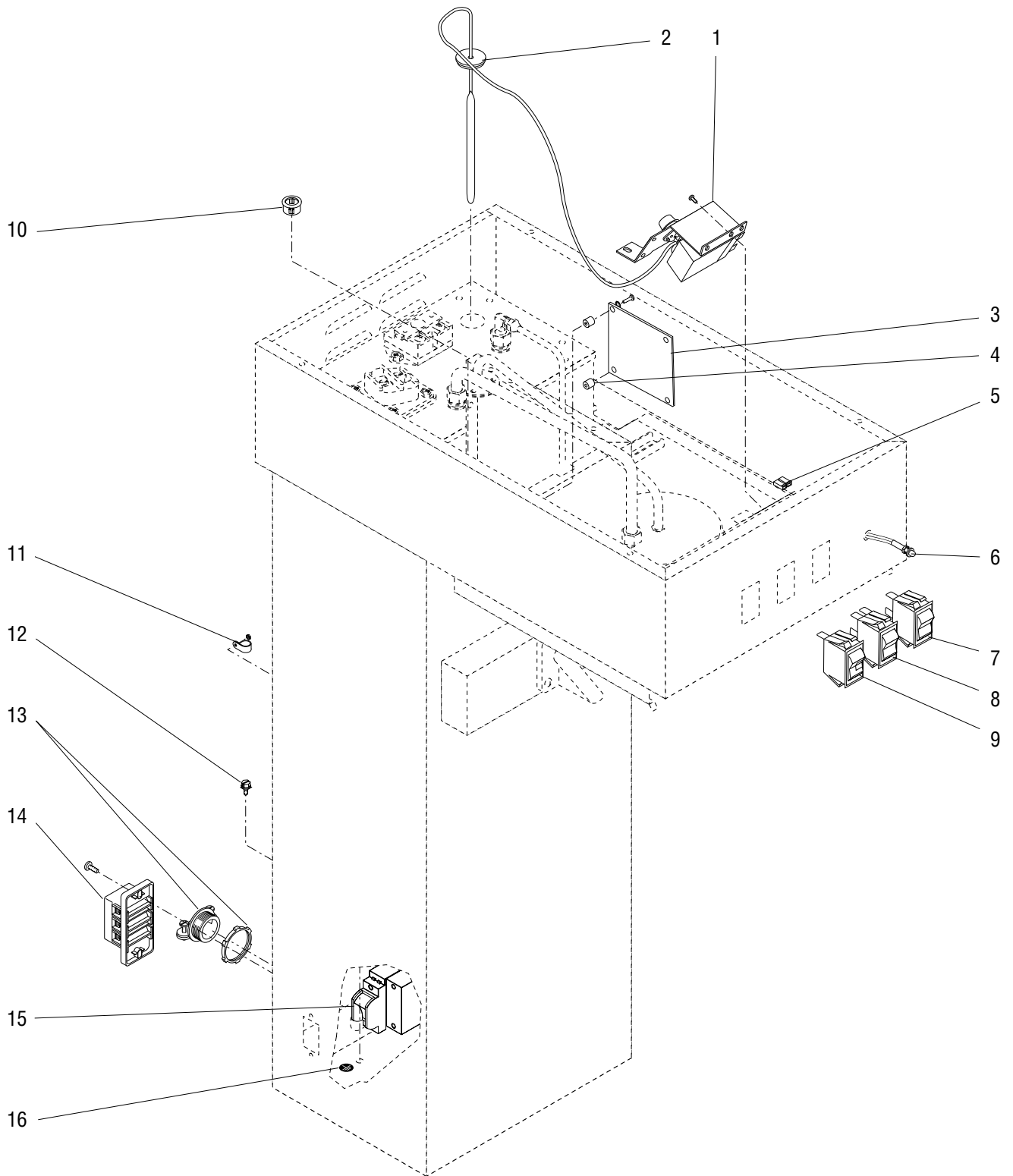

## ELECTRICAL & OPERATING CONTROLS

ITEM	PART NO.	QTY.	DESCRIPTION
1	03024.0005	1	Thermostat Assy, 206 F° (Includes Crommet)
	01310.0000	1	Screw, Pan Head #6-32 x .25"
	01510.0000	1	Lockwasher, External Tooth #6
	20762.0000	2	Screw, Binding Head #8-32 x .25" (Terminal)
2	07073.0001	1	Grommet, Thermostat
3	32400.0002	1	Timer, Digital 120V
	01347.0000	2	Screw, Truss Head #6-32 x .375"
	01388.0000	2	Screw, Pan Head #6-32 x .75"
	01510.0000	2	Lockwasher, External Tooth #6
4	01533.0000	2	Spacer, .171" I.D. x .375" O.D. x .375" LG
5	07014.0000	2	Terminal Housing
6	12984.0004	1	Lamp Assy, Green
	25292.0000	1	Lockwasher M6
	34130.0000	1	Nut M6
7	02628.0000	1	Switch, START
8	39178.0000	1	Switch, BATCH SELECT
9	02753.0000	1	Switch, ON/OFF, Lighted
10	00614.0000	1	Bushing, .469" I.D.
11	00603.0000	1	Clamp, Hose.438" ID
	00970.0000	1	Nut, Keps #8-32
12	01309.0000	1	Screw, Pan Head w/Terminal Washer #10-32 x .50"
13	01590.0000	1	Connector, Cable .75" NPS
14	07038.0000	1	Terminal Block, 3 Pole Red/Whi/Blk
	01317.0000	2	Screw, Truss Head #8-32 x .50"
15	38894.0001	1	Switch, Master ON/OFF
	01308.0002	2	Screw, Truss Head, Locking #6-32 x .25" (Mounting)
	01327.0000	4	Screw, Pan Head #10-32 x .38" (Terminals)
	01512.0000	4	Lockwasher, Ext.-tooth #10
16	00824.0000	1	Decal, Ground

The following items are not illustrated

17	24533.0002	1	Wiring Harness, Main
18	38920.0000	1	Wiring Harness, Master ON/OFF Switch
19	21016.0030*	1	Lead, 16 Ga. BLK (Thermostat to Ready Lamp)
20	21016.0031*	1	Lead, 16 Ga. BLU/BLK (Thermostat to Ready Lamp)
21	04243.0000	2	Terminal Housing
22	21012.0004	1	Lead, 12 Ga. BLK (Limit to Tank Heater)
23	02240.0002	1	Lead Assy, Timer to Batch Selector Switch
24	00636.0000	1	Shield, Polyester - Timer Board
25	00637.0003*	1	Shield, Polyester - Switch Terminals
26	26858.0000	1	Cord, Power

\* Indicates the part number listed is for reference only. See DESCRIPTION for possible service replacement.

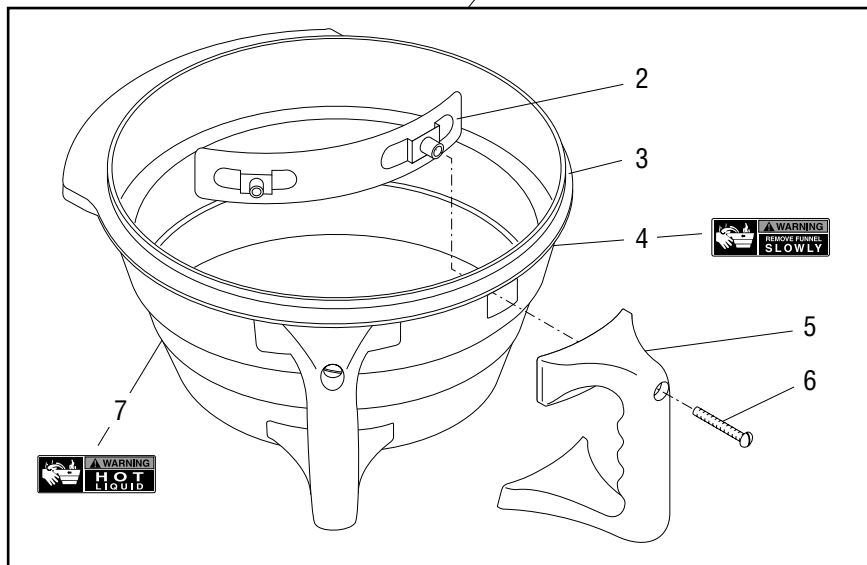
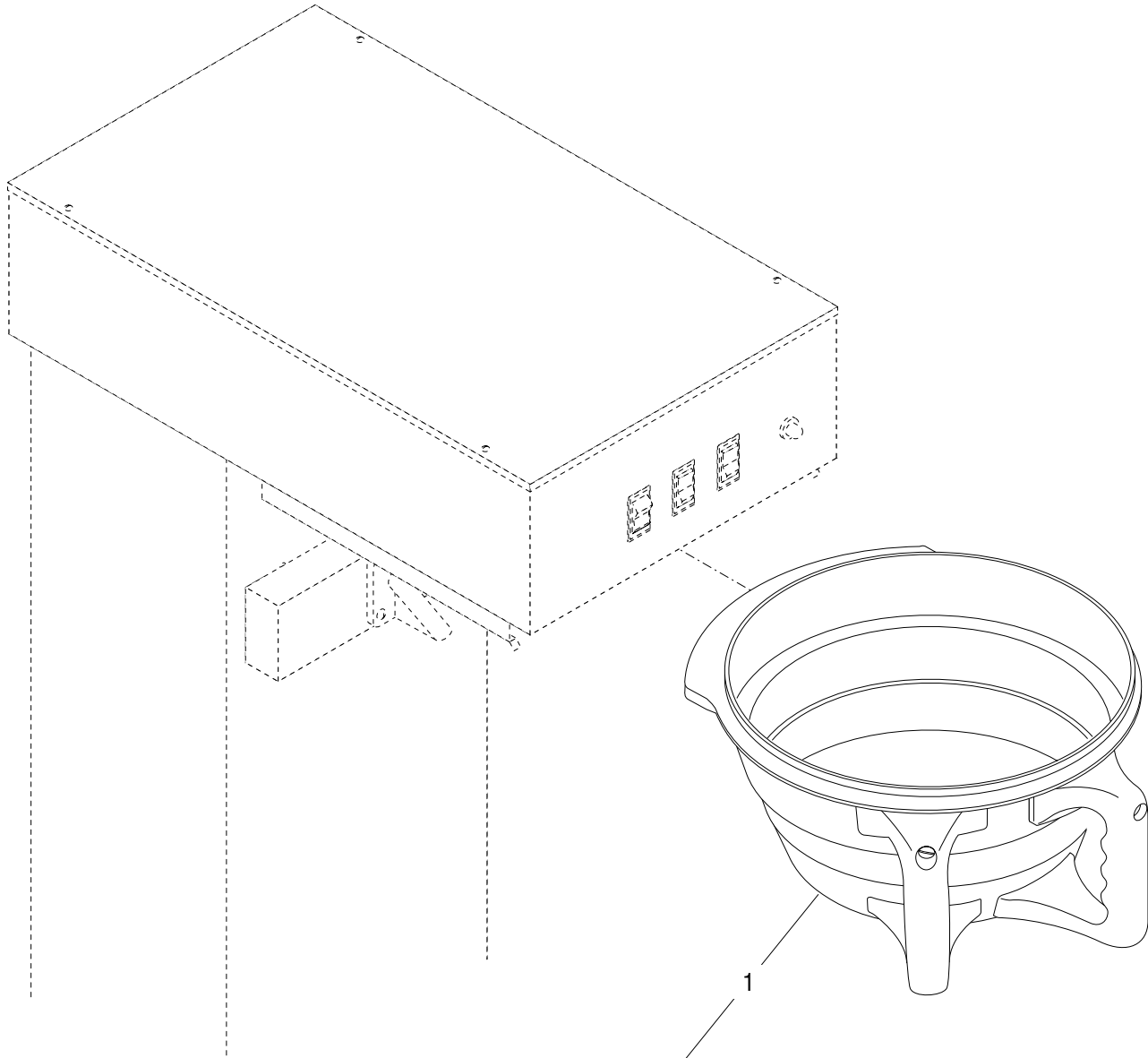

P3494.70

## FUNNEL

ITEM	PART NO.	QTY.	DESCRIPTION
1	24657.0000	1	Funnel Assembly (Includes items 2 thru 7)
2	24659.0000	1	Bracket, Funnel
3	24658.0000*	1	Funnel (Order item 1)
4	03408.0000	1	Decal, WARNING Remove Funnel Slowly
5	43029.1000	2	Handle, Funnel (Includes Item 6)
6	12499.0002	2	Screw, Round Head .25"-20 x 1.50"
7	03409.0000	1	Decal, WARNING Hot Liquid

\* Indicates the part number listed is for reference only. See DESCRIPTION for possible service replacement.

## NUMERICAL INDEX

PART NO.	PAGE NO.	PART NO.	PAGE NO.	PART NO.	PAGE NO.	PART NO.	PAGE NO.
00310.0000.....	9	03772.0001.....	5	25292.0000.....	13		
00310.0005.....	9	03773.0000.....	5	25920.0003.....	7		
00400.0001.....	9	04243.0000.....	13	25926.0000.....	7		
00412.0001.....	9	05515.0000.....	7	26858.0000.....	13		
00432.0001.....	9	07014.0000.....	13	28479.0000.....	9		
00435.0001.....	9	07038.0000.....	13	28480.0000.....	11		
00459.0000.....	9	07073.0001.....	13	28481.0000.....	11		
00463.0000.....	9	10793.0000.....	5	32400.0002.....	13		
00464.0001.....	9	11707.0012.....	11	32540.0000.....	5		
00484.0001.....	9	11707.0013.....	11	34130.0000.....	13		
00603.0000.....	11,13	11707.1000.....	11	37881.0000.....	5		
00614.0000.....	13	11707.1001.....	11	38894.0001.....	11		
00636.0000.....	13	11707.1002.....	11	38920.0000.....	13		
00637.0003.....	13	12249.0008.....	5	39178.0000.....	11		
00656.0001.....	5	12305.1000.....	7	43029.1000.....	15		
00668.0000.....	5	12322.1000.....	7				
00824.0000.....	13	12377.0000.....	7				
00831.0000.....	5	12398.0000.....	7				
00906.0000.....	7	12422.0000.....	9				
00908.0000.....	7	12499.0002.....	15				
00917.0000.....	5	12984.0004.....	13				
00929.0001.....	7	20526.1330.....	9				
00970.0000.....	5,9,11,13	20528.1330.....	9				
00971.0000.....	7	20762.0000.....	13				
01075.0000.....	7	21012.0004.....	13				
01085.0002.....	9	21016.0030.....	13				
01111.0000.....	11	21016.0031.....	13				
01154.0001.....	9	22249.0000.....	9				
01155.0000.....	9	22397.0001.....	9				
01315.0000.....	5	23717.0003.....	7				
01308.0002.....	13	23721.0000.....	9				
01309.0000.....	13	23820.1000.....	9				
01310.0000.....	13	24427.0000.....	5				
01317.0000.....	13	24431.0000.....	5				
01317.0003.....	5	24431.0001.....	5				
01327.0000.....	9,13	24435.1000.....	5				
01347.0000.....	13	24441.0001.....	5				
01382.0000.....	5	24444.0000.....	5				
01382.0002.....	9	24447.0000.....	5				
01388.0000.....	13	24527.0000.....	7				
01502.0000.....	9	24531.0000.....	7				
01510.0000.....	13	24532.0000.....	7				
01512.0000.....	13	24533.0002.....	13				
01532.0000.....	9	24569.0000.....	9				
01533.0000.....	13	24599.0001.....	9				
01590.0000.....	13	24600.0000.....	5				
01592.0000.....	11	24613.0001.....	9				
02240.0002.....	13	24614.1001.....	9				
02308.0000.....	5,7	24637.0000.....	7				
02628.0000.....	13	24657.0000.....	15				
02753.0000.....	13	24658.0000.....	15				
03024.0005.....	13	24659.0000.....	15				
03170.0000.....	9	24684.0000.....	9				
03408.0000.....	15	24698.0000.....	5				
03409.0000.....	15	24699.0000.....	5				
03717.0000.....	9	25137.0001.....	5				