



BUNN® IMIX®-3S

Quality Since 1840

IMIX®-5S



INSTALLATION & OPERATING GUIDE

BUNN-O-MATIC CORPORATION

POST OFFICE BOX 3227

SPRINGFIELD, ILLINOIS 62708-3227

PHONE: (217) 529-6601 FAX: (217) 529-6644

To ensure you have the latest revision of the Operating Manual, or to view the Illustrated Parts Catalog, Programming Manual, or Service Manual, please visit the Bunn-O-Matic website, at www.bunn.com. This is absolutely FREE, and the quickest way to obtain the latest catalog and manual updates. For Technical Service, contact Bunn-O-Matic Corporation at 1-800-286-6070.



BUNN-O-MATIC COMMERCIAL PRODUCT WARRANTY

Bunn-O-Matic Corp. ("BUNN") warrants equipment manufactured by it as follows:

- 1) Airpots, thermal carafes, decanters, GPR servers, iced tea/coffee dispensers, MCR/MCP/MCA single cup brewers, thermal servers and ThermoFresh® servers (mechanical and digital) 1 year parts and 1 year labor.
- 2) All other equipment - 2 years parts and 1 year labor plus added warranties as specified below:
 - a) Electronic circuit and/or control boards - parts and labor for 3 years.
 - b) Compressors on refrigeration equipment - 5 years parts and 1 year labor.
 - c) Grinding burrs on coffee grinding equipment to grind coffee to meet original factory screen sieve analysis - parts and labor for 4 years or 40,000 pounds of coffee, whichever comes first.

These warranty periods run from the date of installation BUNN warrants that the equipment manufactured by it will be commercially free of defects in material and workmanship existing at the time of manufacture and appearing within the applicable warranty period. This warranty does not apply to any equipment, component or part that was not manufactured by BUNN or that, in BUNN's judgment, has been affected by misuse, neglect, alteration, improper installation or operation, improper maintenance or repair, non periodic cleaning and descaling, equipment failures related to poor water quality, damage or casualty. In addition, the warranty does not apply to replacement of items subject to normal use including but not limited to user replaceable parts such as seals and gaskets. This warranty is conditioned on the Buyer 1) giving BUNN prompt notice of any claim to be made under this warranty by telephone at (217) 529-6601 or by writing to Post Office Box 3227, Springfield, Illinois 62708-3227; 2) if requested by BUNN, shipping the defective equipment prepaid to an authorized BUNN service location; and 3) receiving prior authorization from BUNN that the defective equipment is under warranty.

THE FOREGOING WARRANTY IS EXCLUSIVE AND IS IN LIEU OF ANY OTHER WARRANTY, WRITTEN OR ORAL, EXPRESS OR IMPLIED, INCLUDING, BUT NOT LIMITED TO, ANY IMPLIED WARRANTY OF EITHER MERCHANTABILITY OR FITNESS FOR A PARTICULAR PURPOSE. The agents, dealers or employees of BUNN are not authorized to make modifications to this warranty or to make additional warranties that are binding on BUNN. Accordingly, statements by such individuals, whether oral or written, do not constitute warranties and should not be relied upon.

If BUNN determines in its sole discretion that the equipment does not conform to the warranty, BUNN, at its exclusive option while the equipment is under warranty, shall either 1) provide at no charge replacement parts and/or labor (during the applicable parts and labor warranty periods specified above) to repair the defective components, provided that this repair is done by a BUNN Authorized Service Representative; or 2) shall replace the equipment or refund the purchase price for the equipment.

THE BUYER'S REMEDY AGAINST BUNN FOR THE BREACH OF ANY OBLIGATION ARISING OUT OF THE SALE OF THIS EQUIPMENT, WHETHER DERIVED FROM WARRANTY OR OTHERWISE, SHALL BE LIMITED, AT BUNN'S SOLE OPTION AS SPECIFIED HEREIN, TO REPAIR, REPLACEMENT OR REFUND.

In no event shall BUNN be liable for any other damage or loss, including, but not limited to, lost profits, lost sales, loss of use of equipment, claims of Buyer's customers, cost of capital, cost of down time, cost of substitute equipment, facilities or services, or any other special, incidental or consequential damages.

392, A Partner You Can Count On, Air Infusion, AutoPOD, AXIOM, BrewLOGIC, BrewMETER, Brew Better Not Bitter, BrewWISE, BrewWIZARD, BUNN Espresso, BUNN Family Gourmet, BUNN Gourmet, BUNN Pour-O-Matic, BUNN, BUNN with the stylized red line, BUNNlink, Bunn-O-Matic, Bunn-O-Matic, BUNNserve, BUNNSERVE with the stylized wrench design, Cool Froth, DBC, Dr. Brew stylized Dr. design, Dual, Easy Pour, EasyClear, EasyGard, FlavorGard, Gourmet Ice, Gourmet Juice, High Intensity, iMIX, Infusion Series, Intellisteam, My Café, Phase Brew, PowerLogic, Quality Beverage Equipment Worldwide, Respect Earth, Respect Earth with the stylized leaf and coffee cherry design, Safety-Fresh, savemycoffee.com, Scale-Pro, Silver Series, Single, Smart Funnel, Smart Hopper, SmartWAVE, Soft Heat, SplashGard, The Mark of Quality in Beverage Equipment Worldwide, ThermoFresh, Titan, trifacta, TRIFECTA (stylized logo), Velocity Brew, Air Brew, Beverage Bar Creator, Beverage Profit Calculator, Brew better, not bitter., Build-A-Drink, BUNNSource, Coffee At Its Best, Cyclonic Heating System, Daypart, Digital Brewer Control, Element, Milk Texturing Fusion, Nothing Brews Like a BUNN, Picture Prompted Cleaning, Pouring Profits, Signature Series, Sure Tamp, Tea At Its Best, The Horizontal Red Line, Ultra are either trademarks or registered trademarks of Bunn-O-Matic Corporation. The commercial trifacta® brewer housing configuration is a trademark of Bunn-O-Matic Corporation.

INTRODUCTION

This equipment dispenses hot beverages or soups on demand from powdered product. It is indoor use only on a sturdy counter or shelf.

USER NOTICES

The notices on this dispenser should be kept in good condition. Replace unreadable or damaged labels.

⚠ WARNING

- ◆ Fill water tank before turning - on - thermostat or connecting appliance to power source.
- ◆ Use only on a properly protected circuit capable of the rated load.
- ◆ Electrically ground the chassis.
- ◆ Follow national/local electrical codes.
- ◆ Do not use near combustibles.
- ◆ Do not deform plug or cord.

FAILURE TO COMPLY RISKS EQUIPMENT DAMAGE, FIRE, OR SHOCK HAZARD

READ THE ENTIRE OPERATING MANUAL BEFORE BUYING OR USING THIS PRODUCT

THIS APPLIANCE IS HEATED WHENEVER CONNECTED TO A POWER SOURCE

00831.0000M 11/14 ©1998 BUNN-O-MATIC CORPORATION

00831.0000



00824.0002

⚠ WARNING

To reduce the risk of electric shock, do not remove or open cover. No user-serviceable parts inside. Authorized service personnel only. Disconnect power before servicing.

37881.0000

As directed in the International Plumbing Code of the International Code Council and the Food Code Manual of the Food and Drug Administration (FDA), this equipment must be installed with adequate backflow prevention to comply with federal, state and local codes. For models installed outside the U.S.A., you must comply with the applicable Plumbing /Sanitation Code for your area.

00656.0001

CONTROL THERMOSTAT ADJUSTMENT

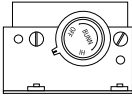

200 F

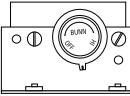

190 F

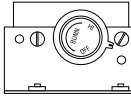

180 F

APPROXIMATE THERMOSTAT TEMPERATURE SETTINGS

28368.0000A 10/97 © 1997 BUNN-O-MATIC CORPORATION

28368.0000

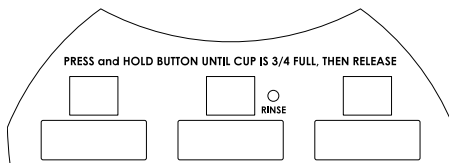

IMIX-3S

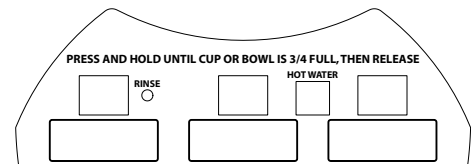

IMIX-3S w/Hot Water

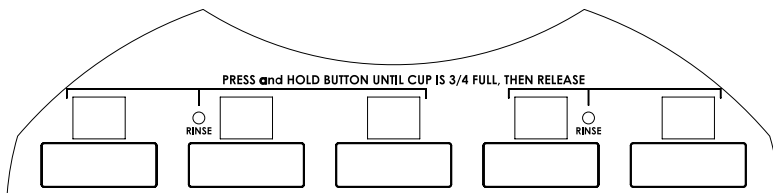

IMIX-5S

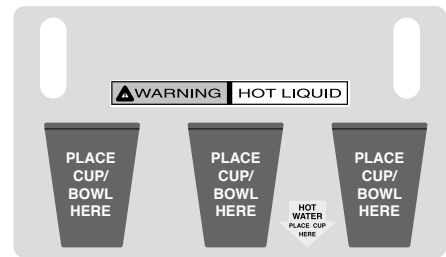

29216.0005



28328.0010



28328.0011

CE REQUIREMENTS

- This appliance must be installed in locations where it can be overseen by trained personnel.
- For proper operation, this appliance must be installed where the temperature is between 5°C to 35°C.
- Appliance shall not be tilted more than 10° for safe operation.
- An electrician must provide electrical service as specified in conformance with all local and national codes.
- This appliance must not be cleaned by water jet.
- This appliance can be used by persons aged from 18 years and above if they have been given supervision or instruction concerning use of the appliance in a safe way and if they understand the hazards involved.
- Keep the appliance and its cord out of reach of children aged less than 18 years.
- Appliances can be used by persons 18 years and above with reduced physical, sensory or mental capabilities or lack of experience and knowledge if they have been given supervision or instruction concerning use of the appliance in a safe way and understand the hazards involved.
- Children under the age of 18 years should be supervised to ensure they do not play with the appliance.
- If the power cord is ever damaged, it must be replaced by the manufacturer or authorized service personnel with a special cord available from the manufacturer or its authorized service personnel in order to avoid a hazard.
- Machine must not be immersed for cleaning.
- Cleaning and user maintenance shall not be made by children unless they are older than 18 years and supervised.
- This appliance is intended to be used in household and similar applications such as:
 - staff kitchen areas in shops, offices and other working environments;
 - by clients in hotels, motels and other residential type environments;
 - bed and breakfast type environments.
- This appliance not intended to be used in applications such as:
 - farm houses;
- Access to the service areas permitted by Authorized Service personnel only.
- The A-Weighted sound pressure level is below 70 dBA.

NORTH AMERICAN REQUIREMENTS

- This appliance must be installed in locations where it can be overseen by trained personnel.
- For proper operation, this appliance must be installed where the temperature is between 41°F to 95°F (5°C to 35°C).
- Appliance shall not be tilted more than 10° for safe operation.
- An electrician must provide electrical service as specified in conformance with all local and national codes.
- This appliance must not be cleaned by pressure washer.
- This appliance can be used by persons aged from 18 years and above if they have been given supervision or instruction concerning use of the appliance in a safe way and if they understand the hazards involved.
- Keep the appliance and its cord out of reach of children aged less than 18 years.
- Appliances can be used by persons 18 years and above with reduced physical, sensory or mental capabilities or lack of experience and knowledge if they have been given supervision or instruction concerning use of the appliance in a safe way and understand the hazards involved.
- Children under the age of 18 years should be supervised to ensure they do not play with the appliance.
- If the power cord is ever damaged, it must be replaced by the manufacturer or authorized service personnel with a special cord available from the manufacturer or its authorized service personnel in order to avoid a hazard.
- Machine must not be immersed for cleaning.
- Cleaning and user maintenance shall not be made by children unless they are older than 18 years and supervised.
- This appliance is intended for commercial use in applications such as:
 - staff kitchen areas in shops, offices and other working environments;
 - by clients in hotel and motel lobbies and other similar types of environments;
- Access to the service areas permitted by Authorized Service personnel only.

INITIAL SET-UP

1. Apply the four non-skid pads from the parts box to the bottom of the legs.
2. Remove the drip tray assembly, drip tray bracket, and splash panel assembly from the parts box.
3. Place a set of key holes in the drip tray bracket over the lower two screws in the panel below the hopper access door; push down gently and tighten screws.
4. Place the set of key holes in the splash panel over the upper two screws and position so the screws are between the holes.

ELECTRICAL REQUIREMENTS

WARNING - If the power cord is ever damaged, it must be replaced by the manufacturer or its service agent with a special cord available from the manufacturer or its service agent in order to avoid a hazard.

CAUTION - The dispenser must be disconnected from the power source until specified in *Electrical Hook-Up*.

The 120 volt version of this dispenser has an attached cordset.

Refer to the dispenser's dataplate for exact voltage requirements.

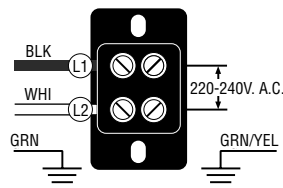

**220-240V AC
single phase models**

Note: This electrical service consists of 2 current carrying conductors (L1 and L2) and a separate conductor for earth ground.

ELECTRICAL HOOK-UP

CAUTION – Improper electrical installation will damage electronic components.

1. An electrician must provide electrical service as specified.
2. Using a voltmeter, check the voltage and color coding of each conductor at the electrical source.
3. Open the front door of the dispenser and place the heater switch in the “OFF” (upper position).
4. Connect the dispenser to the power source.
5. If plumbing is to be hooked-up later be sure the dispenser is disconnected from the power source. If plumbing has been hooked-up, the dispenser is ready for *Initial Fill & Heat*.

PLUMBING REQUIREMENTS

This dispenser must be connected to a COLD WATER system with operating pressure between 20 and 100 psi (0.138 and 0.690 MPa). This water source must be capable of producing a minimum flow rate of 4.5 fl. oz. (133.1 ml) per second. A shut-off valve should be installed in the line before the dispenser. Install a regulator in the line when pressure is greater than 100 psi (0.690 MPa) to reduce it to 50 psi (0.345 MPa). The water inlet fitting is .38" (9.52 mm) flare.

NOTE - At least 18 inches (457 mm) of an FDA approved flexible beverage tubing, such as reinforced braided polyethylene or silicone, before the dispenser will facilitate movement to clean the countertop. It can be purchased direct from Bunn-O-Matic (part number 32759.10--[See Illustrated Parts Catalog for complete part number]). Bunn-O-Matic does not recommend the use of a saddle valve to install the dispenser. The size and shape of the hole made in the supply line by this type of device may restrict water flow.

As directed in the International Plumbing Code of the International Code Council and the Food Code Manual of the Food and Drug Administration (FDA), this equipment must be installed with adequate backflow prevention to comply with federal, state and local codes. For models installed outside the U.S.A., you must comply with the applicable Plumbing /Sanitation Code for your area.

PLUMBING HOOK-UP

1. Flush the water line and securely attach it to the flare fitting on the bottom of the dispenser.
2. Turn-on the water supply.

NOTE - Water pipe connections and fixtures directly connected to a potable water supply shall be sized, installed and maintained in accordance with federal, state and local codes.

INITIAL FILL & HEAT

CAUTION - The dispenser must be disconnected from the power source throughout the initial set-up, except when specified in the instructions.

1. Turn-on the water supply and connect the dispenser to the power source.
2. Water will automatically flow into the tank to the proper level and then shut-off. This will take less than five minutes.
3. When the tank is full of water, open the front door and place the heater switch in the "ON" (lower) position. A tank full of cold water will take approximately eighty minutes (IMIX-5S) or forty-five minutes (IMIX-3S) for the water to heat on 120 volt versions or forty minutes (IMIX-5S) or twenty-five minutes (IMIX-3S) for 120/208 volt versions and 120/240 volt versions.

During this waiting period, complete these dispenser set-up steps:

- a. Place the drip tray in front of the dispenser. Set the drip tray cover in place.
- b. Place a set of keyholes in the cup locator plate over the screws beneath the hopper access door and push down gently.
- c. Fill the hoppers with the dry product to be dispensed.

PRESET TANK TEMPERATURE

Tank temperatures have been preset at the factory to 180°F (82°C). Bunn recommends that to provide the best quality beverage, the installer adjust the tank temperature to the powder product manufacturer's recommended temperature for the hot powder product being used.

LIQUID LEVEL CONTROL

The system automatically maintains the hot water tank's level by energizing the refill solenoid when the water level drops below the liquid level probe. If the system has not successfully refilled in 15 minutes, a refill error occurs. When a refill error occurs, the refill solenoid is de-energized and the left rinse L.E.D. will flash about once every 5 seconds. Once the cause of the refill error has been investigated (see the troubleshooting guide in the Operating and Service Manual) and cured, the system can be reset by placing the Rinse/Run switch in the programming (center) position, momentarily.

RINSE TIMERS

The dispenser is shipped from the factory with the rinse timers disabled. To enable the rinse timers, remove power from the dispenser, remove the lower access panel, and remove the jumper from J1 of the control boards. Replace the lower access panel, and return power to the dispenser. When enabled, the rinse timers automatically keep track of the time since the dispenser was last run through a rinse sequence. If the dispenser detects that a rinse sequence has not been run for 8 hours, the appropriate rinse L.E.D. will flash continually. If, after an additional 4 hours (12 hours total), a rinse sequence has still not been run, the appropriate rinse L.E.D. will light continuously, and the appropriate hopper drives will be disabled until a rinse sequence has been run.

RUNNING A RINSE SEQUENCE

1. Place the rinse/run switch in the rinse position.
2. Sequentially, or simultaneously, at each of the positions dispense for at least 10 seconds.
3. After the rinse L.E.D. has extinguished, the rinse timer is reset.
4. Return the rinse/run switch to the run position.

DISPENSER USE

1. Simply place a cup on the drip tray beneath the dispensing tip.
2. Press the button and dispense the beverage.
3. Release the button when the cup is approximately 3/4 full and allow the whipper chamber to drain (whipper models only).

NOTE - The whipper chamber must drain at the end of each dispense.

HOPPER THROW TEST

The hopper throw rate, grams per second (g/s) or ounces per second (oz./s), can be checked by automatically running the hopper motor for 10 seconds.

1. Remove the steam collector and mixing chamber (whipper models only) from under the hopper to be checked.
2. Position a small cup under the hopper outlet.
3. Place the rinse/run switch in the center (program) position.
4. Press and hold the dispense switch of the appropriate chamber for 5 seconds. The hopper motor will run for 10 seconds at the programmed speed.
5. Remove the cup and weigh the dispensed product. To calculate the throw rate (g/s or oz./s), divide the total weight of the dispensed product by 10.
6. Replace the mixing chamber and steam collector, and return the rinse/run switch to the run position.

PREVENTIVE MAINTENANCE

Bunn-O-Matic® Corporation recommends that preventive maintenance be performed at regular intervals. Maintenance should be performed by a qualified service technician. For Technical Service, contact Bunn-O-Matic® Corporation at 1-800-286-6070.

NOTE: Replacement parts or service caused by failure to perform required maintenance is not covered by warranty.

Cycle (months)	Item	Part Number
6	Mixing Chamber Kit	32906.0001
3 or as needed	Whipper Shaft Seal Kit	26356.1000

CLEANING

The use of a damp cloth rinsed in any mild, non-abrasive, liquid detergent is recommended for cleaning all surfaces on Bunn-O-Matic equipment. Do **NOT** clean this equipment with a water jet device.



1 x 24h

BUNN®

1. Rinse out Whipper Chambers by placing RINSE/RUN switch in the "RINSE" position and activating DISPENSE switches.
2. Turn elbow up, remove Hoppers, refill with product and replace hoppers into dispenser.
3. Empty Drip Tray and wash in a solution of dish detergent.

1. Para limpiar las camaras de mezcla, coloque el interruptor en la posición ENJUAGUE/MARCHA ("RINSE/RUN") y pulse el boton para espumar y distribuir la bebida ("DISPENSE").
2. Gire el codo hacia arriba, remueva las tolvas, llene las tolvas con producto y coloque las tolvas nuevamente en la maquina.
3. Vacie la bandeja de goteo y limpiela con un detergente liquido suave no abrasivo.



1 x 7d

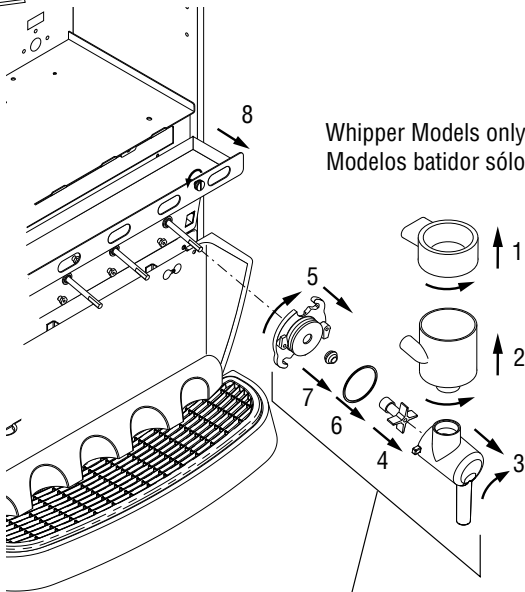

Whipper Models only
Modelos batidor sólo

- | | |
|-------------|---------------|
| a. Wash | a. Lave |
| b. Rinse | b. Enjuague |
| c. Sanitize | c. Desinfecte |
| d. Dry | d. Seque |

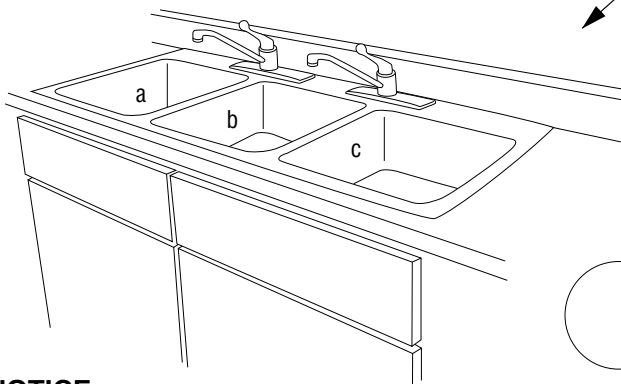
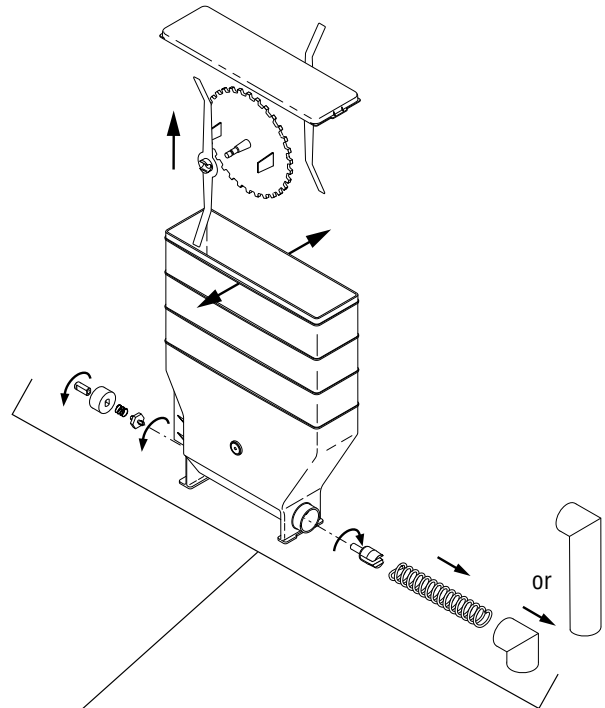

NOTICE

The cleaning instructions noted above are for non-dairy sugar based food products. When dispensing any other food product, the cleaning cycle for the whipping chamber assembly and ejector elbow must be performed daily.

NOTA:

Las instrucciones de limpieza descritas anteriormente excluyen productos lacteos azucarados. La limpieza de las camaras de mezcla y de los codos de salida de cada tolva deberá realizarse diariamente.

ADJUSTMENTS

The beverage solenoid is preset to dispense approximately 9/10 ounce per second (26 mL/sec) or approximately 4/10 ounce per second (12 mL/sec) on non whipper models (oatmeal, etc.). This amount can be adjusted:

1. Disconnect the dispenser from the power source.
2. Remove the hoppers and the access panel behind the hoppers.
3. Rotate the control at the base of the solenoid clockwise to decrease or counterclockwise to increase the amount of water.
4. Replace access panel when finished.

HOPPER MOTOR SPEED PROGRAMING

NOTE: The hopper dispense rates are preset at the factory and can be individually programmed per hopper, as follows:

1. Place the rinse/run switch in the center (program) position.
2. Hold the increase/decrease switch in the desired (increase or decrease) position.
3. While holding the increase/decrease switch, press and release the dispense switch for the chamber you wish to adjust. Each time the dispense switch is pressed, the rinse L.E.D. will flash, and the motor speed for that hopper will be increased/decreased by approximately 2 1/2%.
4. Return the rinse/run switch to the run position after hopper motor speed adjustments are complete.

For IMIX-3S only:

5. Once any of the three hopper motors has been programmed to the desired speed, either or both of the other hopper motors can be set to the same speed as follows:
 - a. Place the rinse/run switch in the center (program) position.
 - b. Press and hold the dispense switch that has been programmed for the correct speed.

NOTE: Care must be taken not to exceed 5 seconds, or a hopper throw test will occur.

- c. Momentarily press the dispense switch for the hopper motor to be programmed. The rinse L.E.D. will light for approximately 1 second, indicating that the speeds have been set equal.
- d. Release both dispense switches.
- e. Repeat step 5. b. through 5. d. for remaining hopper motor if desired.
- f. Return the rinse/run switch to the run position after hopper motor speed adjustments are complete.

DRAINING THE HOT WATER TANK

CAUTION - The dispenser must be disconnected from the power source throughout these steps.

1. Disconnect the dispenser from the power source.
2. Place the tank heater switch in the "OFF" position.
3. Shut-off and disconnect the incoming water supply.
4. Remove the front, lower access panel.
5. Pull out drain tube to empty into a sink or a container with a minimum of 7-1/2 gallon (28.5 L) capacity.
6. Make sure drain clamp is closed. Then, remove drain plug.
7. Direct tube into sink or container and open drain clamp. Continue draining tank until ALL of the water is out.

WARNING: Be very careful with the draining water because it can be very hot.

8. Close drain clamp, insert drain plug, place drain tube back into machine, and replace lower access panel.

NOTE - The dispenser must be refilled using the *INITIAL FILL & HEAT* steps before reconnecting to the power source.