

BUNN®

IMIX®-5S+ HOT & ICED



INSTALLATION & OPERATING GUIDE

BUNN-O-MATIC CORPORATION

POST OFFICE BOX 3227

SPRINGFIELD, ILLINOIS 62708-3227

PHONE: (217) 529-6601 FAX: (217) 529-6644

To ensure you have the latest revision of the Operating Manual, or to view the Illustrated Parts Catalog, Programming Manual, or Service Manual, please visit the Bunn-O-Matic website, at www.bunn.com. This is absolutely FREE, and the quickest way to obtain the latest catalog and manual updates. For Technical Service, contact Bunn-O-Matic Corporation at 1-800-286-6070.

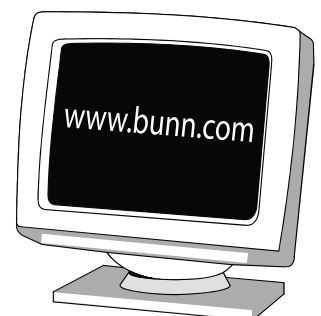

BUNN-O-MATIC COMMERCIAL PRODUCT WARRANTY

Bunn-O-Matic Corp. ("BUNN") warrants equipment manufactured by it as follows:

- 1) Airpots, thermal carafes, decanters, GPR servers, iced tea/coffee dispensers, MCP/MCA pod brewers thermal servers and Thermofresh servers (mechanical and digital)- 1 year parts and 1 year labor.
- 2) All other equipment - 2 years parts and 1 year labor plus added warranties as specified below:
 - a) Electronic circuit and/or control boards - parts and labor for 3 years.
 - b) Compressors on refrigeration equipment - 5 years parts and 1 year labor.
 - c) Grinding burrs on coffee grinding equipment to grind coffee to meet original factory screen sieve analysis - parts and labor for 4 years or 40,000 pounds of coffee, whichever comes first.

These warranty periods run from the date of installation BUNN warrants that the equipment manufactured by it will be commercially free of defects in material and workmanship existing at the time of manufacture and appearing within the applicable warranty period. This warranty does not apply to any equipment, component or part that was not manufactured by BUNN or that, in BUNN's judgment, has been affected by misuse, neglect, alteration, improper installation or operation, improper maintenance or repair, non periodic cleaning and descaling, equipment failures related to poor water quality, damage or casualty. In addition, the warranty does not apply to replacement of items subject to normal use including but not limited to user replaceable parts such as seals and gaskets. This warranty is conditioned on the Buyer 1) giving BUNN prompt notice of any claim to be made under this warranty by telephone at (217) 529-6601 or by writing to Post Office Box 3227, Springfield, Illinois 62708-3227; 2) if requested by BUNN, shipping the defective equipment prepaid to an authorized BUNN service location; and 3) receiving prior authorization from BUNN that the defective equipment is under warranty.

THE FOREGOING WARRANTY IS EXCLUSIVE AND IS IN LIEU OF ANY OTHER WARRANTY, WRITTEN OR ORAL, EXPRESS OR IMPLIED, INCLUDING, BUT NOT LIMITED TO, ANY IMPLIED WARRANTY OF EITHER MERCHANTABILITY OR FITNESS FOR A PARTICULAR PURPOSE. The agents, dealers or employees of BUNN are not authorized to make modifications to this warranty or to make additional warranties that are binding on BUNN. Accordingly, statements by such individuals, whether oral or written, do not constitute warranties and should not be relied upon.

If BUNN determines in its sole discretion that the equipment does not conform to the warranty, BUNN, at its exclusive option while the equipment is under warranty, shall either 1) provide at no charge replacement parts and/or labor (during the applicable parts and labor warranty periods specified above) to repair the defective components, provided that this repair is done by a BUNN Authorized Service Representative; or 2) shall replace the equipment or refund the purchase price for the equipment.

THE BUYER'S REMEDY AGAINST BUNN FOR THE BREACH OF ANY OBLIGATION ARISING OUT OF THE SALE OF THIS EQUIPMENT, WHETHER DERIVED FROM WARRANTY OR OTHERWISE, SHALL BE LIMITED, AT BUNN'S SOLE OPTION AS SPECIFIED HEREIN, TO REPAIR, REPLACEMENT OR REFUND.

In no event shall BUNN be liable for any other damage or loss, including, but not limited to, lost profits, lost sales, loss of use of equipment, claims of Buyer's customers, cost of capital, cost of down time, cost of substitute equipment, facilities or services, or any other special, incidental or consequential damages.

392, A Partner You Can Count On, AutoPOD, AXIOM, BrewLOGIC, BrewMETER, Brew Better Not Bitter, BrewWISE, BrewWIZARD, BUNN Espresso, BUNN Family Gourmet, BUNN Gourmet, BUNN Pour-O-Matic, BUNN, BUNN with the stylized red line, BUNNlink, Bunn-O-Matic, Bunn-O-Matic, BUNNserve, BUNNSERVE with the stylized wrench design, Cool Froth, DBC, Dr. Brew stylized Dr. design, Dual, Easy Pour, EasyClear, EasyGard, FlavorGard, Gourmet Ice, Gourmet Juice, High Intensity, iMIX, Infusion Series, Intellisteam, My Café, Phase Brew, PowerLogic, Quality Beverage Equipment Worldwide, Respect Earth, Respect Earth with the stylized leaf and coffee cherry design, Safety-Fresh, savemycoffee.com, Scale-Pro, Silver Series, Single, Smart Funnel, Smart Hopper, SmartWAVE, Soft Heat, SplashGard, The Mark of Quality in Beverage Equipment Worldwide, ThermoFresh, Titan, trifacta, Velocity Brew, Air Brew, Air Infusion, Beverage Bar Creator, Beverage Profit Calculator, Brew better, not bitter., BUNNsource, Coffee At Its Best, Cyclonic Heating System, Daypart, Digital Brewer Control, Element, Nothing Brews Like a BUNN, Pouring Profits, Signature Series, Tea At Its Best, The Horizontal Red Line, Ultra are either trademarks or registered trademarks of Bunn-O-Matic Corporation. The commercial trifacta® brewer housing configuration is a trademark of Bunn-O-Matic Corporation.

USER NOTICES

The notices on this dispenser should be kept in good condition. Replace unreadable or damaged labels.

⚠ WARNING
<ul style="list-style-type: none">◆ Fill water tank before turning - on - thermostat or connecting appliance to power source.◆ Use only on a properly protected circuit capable of the rated load.◆ Electrically ground the chassis.◆ Follow national/local electrical codes.◆ Do not use near combustibles.
FAILURE TO COMPLY RISKS EQUIPMENT DAMAGE, FIRE, OR SHOCK HAZARD
READ THE ENTIRE OPERATING MANUAL BEFORE BUYING OR USING THIS PRODUCT
THIS APPLIANCE IS HEATED WHENEVER CONNECTED TO A POWER SOURCE <small>00831.0000F 3/98 ©1998 BUNN-O-MATIC CORPORATION</small>

00831.0000

As directed in the International Plumbing Code of the International Code Council and the Food Code Manual of the Food and Drug Administration (FDA), this equipment must be installed with adequate backflow prevention to comply with federal, state and local codes. For models installed outside the U.S.A., you must comply with the applicable Plumbing /Sanitation Code for your area.

00656.0001

⚠ WARNING
To reduce the risk of electric shock, do not remove or open cover. No user-serviceable parts inside. Authorized service personnel only. Disconnect power before servicing.

37881.0000



28328.0010



00824.0002

INITIAL SET-UP

1. Apply the four non-skid pads from the parts box to the bottom of the legs.
2. Remove the drip tray assembly, drip tray bracket, and splash panel assembly from the parts box.
3. Place a set of key holes in the drip tray bracket over the lower two screws in the panel below the hopper access door; push down gently and tighten screws.
4. Place the set of key holes in the splash panel over the upper two screws and position so the screws are between the holes.

CE REQUIREMENTS

- This appliance must be installed in locations where it can be overseen by trained personnel.
- For proper operation, this appliance must be installed where the temperature is between 5°C to 35°C.
- Appliance shall not be tilted more than 10° for safe operation.
- An electrician must provide electrical service as specified in conformance with all local and national codes.
- This appliance must not be cleaned by water jet.
- This appliance is not intended for use by persons (including children) with reduced physical, sensory or mental capabilities, or lack of experience and knowledge, unless they have been given instructions concerning use of this appliance by a person responsible for its safety.
- Children should be supervised to ensure they do not play with the appliance.
- If the power cord is ever damaged, it must be replaced by the manufacturer or authorized service personnel with a special cord available from the manufacturer or its authorized service personnel in order to avoid a hazard.
- Machine must not be immersed for cleaning.

ELECTRICAL REQUIREMENTS

CAUTION - The dispenser must be disconnected from the power source until specified in Electrical Hook-Up. The 120 volt version of this dispenser has an attached cordset. The mating connector must be a NEMA 5-15R. To access terminal block for high voltage models without a cordset, remove left side panel.

Requirements for brewers without an attached cord set are as follows:

Refer to Data Plate on the Dispenser, and local/national electrical codes to determine circuit requirements.

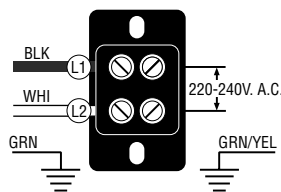

**220-240V AC
single phase models**

Note: This electrical service consists of 2 current carrying conductors (L1 and L2) and a separate conductor for earth ground.

Electrical Hook-Up

CAUTION - Improper electrical installation will damage electronic components.

1. An electrician must provide electrical service as specified.
2. Using a voltmeter, check the voltage and color coding of each conductor at the electrical source.
3. Connect the dispenser to the power source.
4. If plumbing is to be hooked up later be sure the dispenser is disconnected from the power source. If plumbing has been hooked up, the dispenser is ready for Initial Fill & Heat.

PLUMBING REQUIREMENTS

This dispenser must be connected to a **cold water** system with operating pressure between 20 and 90 psi (138-620 kPa) from a 1/2" or larger supply line. A shut-off valve should be installed in the line before the dispenser. Install a regulator in the line when pressure is greater than 90 psi (620 kPa) to reduce it to 50 psi (345 kPa). The water inlet fitting is 1/4" flare.

NOTE - Bunn-O-Matic recommends 1/4" copper tubing for installations of less than 25 feet and 3/8" for more than 25 feet from the 1/2" water supply line. At least 18 inches of an FDA approved flexible beverage tubing, such as reinforced braided polyethylene or silicone, before the dispenser will facilitate movement to clean the countertop. Bunn-O-Matic does not recommend the use of a saddle valve to install the dispenser. The size and shape of the hole made in the supply line by this type of device may restrict water flow.

As directed in the International Plumbing Code of the International Code Council and the Food Code Manual of the Food and Drug Administration (FDA), this equipment must be installed with adequate backflow prevention to comply with federal, state and local codes. For models installed outside the U.S.A., you must comply with the applicable Plumbing /Sanitation Code for your area.

NOTE - If a backflow preventer is required by code, a shock arrestor should be installed between backflow preventer and dispenser. Installing the shock arrestor as close to the dispenser as possible will provide the best results.

NOTE - Water pipe connections and fixtures directly connected to a potable water supply shall be sized, installed and maintained in accordance with federal, state and local codes.

PLUMBING HOOK-UP

1. Flush the water line and securely attach it to the elbow fitting on the bottom of the dispenser.
2. Turn on the water supply.

INITIAL FILL & HEAT

1. Turn on the water supply and connect the dispenser to the power source.
2. Water will automatically flow into the tank to the proper level and then shut-off. This will take less than ten minutes. Tanks full of cold water will take approximately fifty minutes for the water to heat on 120 volt versions, and twenty minutes on 120/240 and 220-240 volt versions.
3. Fill the hopper(s) with the dry product to be dispensed.

PRESET TANK TEMPERATURE

Tank temperatures have been preset at the factory to 180°F (82°C). Bunn recommends that to provide the best quality beverage, the installer adjust the tank temperature to the powder product manufacturer's recommended temperature for the hot powder product being used.

LIQUID LEVEL CONTROL

The system automatically maintains the hot and warm water tank's level by energizing the refill solenoid when the water level drops below the liquid level probe. If the Hot Tank has not successfully refilled in 10 minutes, a refill error occurs. When a refill error occurs, the refill solenoid is de-energized. Once the cause of the refill error has been investigated and cured, the system can be reset by either disconnecting (for at least 5 seconds) and then reconnecting the power to the machine, or by entering one of the program modes (see Programming Modes.)

RINSE TIMER

The dispenser is shipped from the factory with the rinse timer disabled. To enable the rinse timer, refer to Programming the Dispenser and select yes in the “Rinse Alarm ?” screen; set timer to the desired time and exit the programming mode.

When enabled, the rinse timer automatically keeps track of the time since the dispenser was last run through a rinse sequence. If the dispenser detects that a rinse sequence has not been run for the desired time, a message will appear on the LCD display. If the Lockout is set, after an additional 4 hours, a rinse cycle has still not been run, the LCD display will display a message, and the hopper drives will be disabled until a rinse sequence has been run.

RUNNING A RINSE SEQUENCE

1. Place the Normal/Program/Rinse switch (page 9) in the “rinse” position.
2. Sequentially at each position, press all of the dispense switches. The dispenser will run for 10 seconds with the hopper(s) disabled.
3. As each position is rinsed, the LCD display will show which position is being rinsed and count down from 10 seconds.
4. After all positions have been rinsed, return the Normal/Program/Rinse switch to the “Normal” position.

DISPENSER USE - Self Serve

1. Simply place a cup on the drip tray beneath the desired dispensing tip.
2. Press the button to froth and dispense the beverage.
3. Release the button when the cup is approximately $\frac{3}{4}$ full and allow the mixing chamber to drain.

Note - The mixing chamber must drain at the end of each dispense.

DISPENSER USE - Portion Control

1. Simply place a cup on the drip tray beneath the desired dispensing tip.
2. Press the dispense button momentarily, then release.
3. Let the mixing chamber completely drain before removing cup.

HOPPER DISPENSE RATE OF PRODUCT

The hopper dispense rates are preset at the factory. With 22 tooth gear and auger wire, the preset dispense rate is approximately 3 to 5 grams per second. With 30 tooth gear and auger wire, the preset dispense rate is approximately 5 to 7 grams per second. The hopper dispense rates can be individually programmed to a range of dispense rates from approximately 1.5 to 12 grams per second, by following the procedures described in Programming Modes.

DOOR GRAPHIC AND LENS INSTALLATION

Remove the clear lens from the door of the machine. Place the door graphic into position and reinstall the clear lens over the door graphic.

PREVENTIVE MAINTENANCE

Bunn-O-Matic® Corporation recommends that preventive maintenance be performed at regular intervals. Maintenance should be performed by a qualified service technician. For Technical Service, contact Bunn-O-Matic® Corporation at 1-800-286-6070.

NOTE: Replacement parts or service caused by failure to perform required maintenance is not covered by warranty.

Cycle (months)	Item	Part Number
6	Mixing Chamber Kit	32906.0001
3 or as needed	Whipper Shaft Seal Kit	26356.1000

CLEANING

The use of a damp cloth rinsed in any mild, non-abrasive, liquid detergent is recommended for cleaning all surfaces on Bunn-O-Matic equipment. Do **NOT** clean this equipment with a water jet device.



1 x 24h

BUNN®

1. Rinse out Whipper Chambers by placing RINSE/RUN switch in the "RINSE" position and activating DISPENSE switches.
2. Turn elbow up, remove Hoppers, refill with product and replace hoppers into dispenser.
3. Empty Drip Tray and wash in a solution of dish detergent.

1. Para limpiar las camaras de mezcla, coloque el interruptor en la posición ENJUAGUE/MARCHA ("RINSE/RUN") y pulse el boton para espumar y distribuir la bebida ("DISPENSE").
2. Gire el codo hacia arriba, remueva las tolvas, llene las tolvas con producto y coloque las tolvas nuevamente en la maquina.
3. Vacie la bandeja de goteo y limpiela con un detergente liquido suave no abrasivo.



1 x 7d

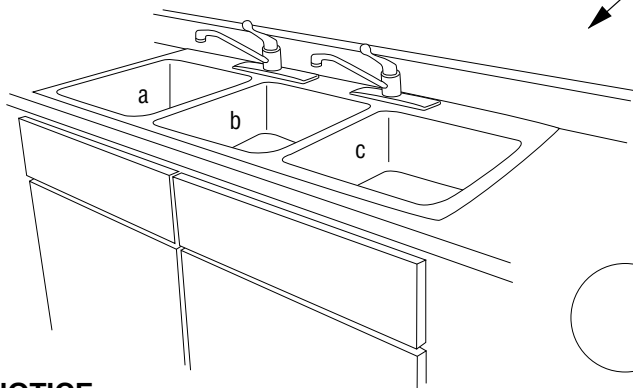
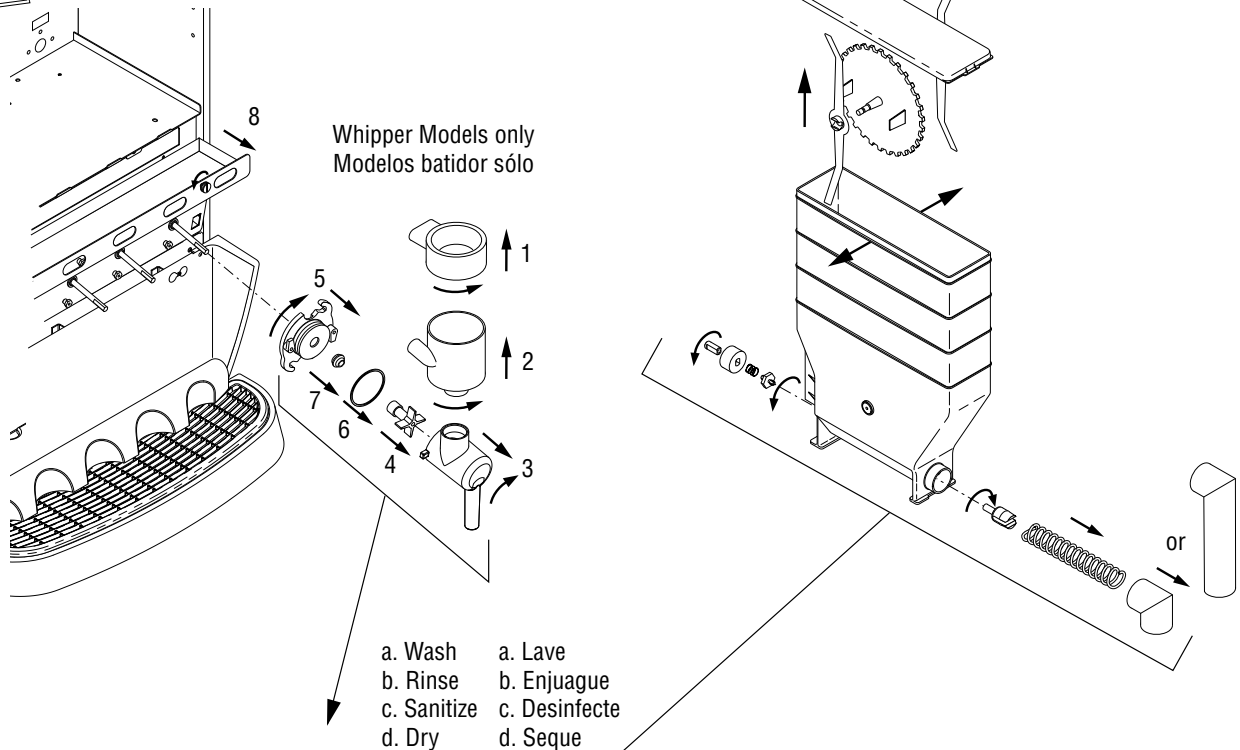

NOTICE

The cleaning instructions noted above are for non-dairy sugar based food products. When dispensing any other food product, the cleaning cycle for the whipping chamber assembly and ejection elbow must be performed daily.

NOTA:

Las instrucciones de limpieza descritas anteriormente excluyen productos lacteos azucarados. La limpieza de las camaras de mezcla y de los codos de salida de cada tolva deberá realizarse diariamente.

37254.0003A 02/13 © 2013 BUNN-O-MATIC CORPORATION

DRAINING THE WATER TANKS

CAUTION - The dispenser must be disconnected from the power source throughout these steps

1. Disconnect the dispenser from the power source.
2. Shut off and disconnect the incoming water supply.
3. Remove the drip tray and access panels below the door.
4. Pull the clamped end of the silicone tube out of the dispenser and direct it into a drain or a container large enough to hold the volume of water in the tank.
5. Make certain the shut off clamp is locked tightly on the tube, then remove the snap type clamp and plug from end of tube.
6. Carefully release the shut off clamp to let the water drain from the tank.
7. Repeat steps 4 - 6 for other tank.

NOTE - The dispenser must be refilled using the *INITIAL FILL & HEAT* steps before reconnecting to the power source.

COOLING FAN SWITCH

For low temperature tank settings of approximately 90°F or over, leave the cooling fan switch, located inside the front door, in the “OFF” position. For low temperature tank settings under 90°F, place the cooling fan switch in the “ON” position. A low end temperature of about 7°F over ambient may be attained when the cooling fan is engaged.



GLOSSARY

<p>HOT TANK XXX° (-) EXIT (+)</p>	<p>Adjust Hot Tank temperature (190° F maximum)</p>	<p>SET PASSWORD ? (-) XXXX (+)</p>	<p>Allows password to be set to prevent altering setup functions</p>
<p>READY TEMP XXX° (-) EXIT (+)</p>	<p>Adjust minimum Hot Tank ready temperature for lockout (185° F maximum)</p>	<p>ENABLE ADS ? NO EXIT YES</p>	<p>Enables “ADS” to be displayed on LCD door display</p>
<p>WARM TANK XXX° (-) EXIT (+)</p>	<p>Adjust Warm Tank temperature (190° F maximum)</p>	<p>ENTER ASSET # ? EXIT YES</p>	<p>Enter asset number of machine</p>
<p>PORTION CONTROL ? NO EXIT YES</p>	<p>Select Portion Control Dispensing</p>	<p>ENABLE SERVICE # NO EXIT YES</p>	<p>Enables service agent telephone number to be displayed</p>
<p>SET CUP SIZE EXMPL TIME</p>	<p>Select setting cup size by Time (seconds) or by Example (Portion Control models only)</p>	<p>TEST SWITCHES ? Use Switch To Test</p>	<p>Allows testing of dispense switches</p>
<p>DISPENSE TO ADD REPEAT SAVE</p>	<p>Press same dispense button to top off cup, or press save to lock in dispense time, or, press repeat to erase dispense time and repeat process.</p>	<p>TEST HEATER ? EXIT YES</p>	<p>Allows manually activating Hot Tank heater</p>
<p>HEAD# TIME (-) ### (+)</p>	<p>Set Dispense Time In Seconds</p>	<p>TEST REFILL ? EXIT YES</p>	<p>Allows manually activating Hot Tank refill valve</p>
<p>DRINK STRENGTH (-) XX (+)</p>	<p>Adjust hopper motor speed for station selected</p>	<p>TEST WARM HTR ? EXIT YES</p>	<p>Allows manually activating Warm Tank heater</p>
<p>XX° CAL → XX° (-) Hot Tank (+)</p>	<p>Calibrate temperature probe</p>	<p>TEST AUGERS ? DISPENSE TO TEST</p>	<p>Allows manually activating hopper motors</p>
<p>XX° CAL → XX° (-) Warm Tank (+)</p>	<p>Calibrate temperature probe</p>	<p>TEST DISP HEADS DISPENSE TO TEST</p>	<p>Allows manually activating dispense valves & whipper motors</p>
<p>235 REFILL 155 (-) EXIT (+)</p>	<p>Set refill probe threshold</p>	<p>FACTORY DEFAULTS NO YES</p>	<p>Resets all functions to factory defaults, and password to 0</p>
<p>Auger Delay (-) .XX sec (+)</p>	<p>Set delay start of hopper after dilution valve opens in station selected</p>		
<p>DISPENSE LOCKOUT NO EXIT YES</p>	<p>Enables lockout of dispensing if below minimum water temperature</p>		
<p>RINSE ALARM ? NO EXIT YES</p>	<p>Enables rinse alarm</p>		
<p>HEAD 1 DISABLE ? NO EXIT YES</p>	<p>Disables all functions and dispensing for station selected</p>		

PROGRAMMING THE DISPENSER

The following function screens are in order of appearance. Each screen will have instructions on how to access, and the procedures to program the various functions of the dispenser. To enable programming, place the “NORMAL/PROGRAM/RINSE” switch in the “PROGRAM” position.

IMPORTANT PROGRAMMING NOTES - READ CAREFULLY

To exit the programming mode at any time, press and release the exit (center) pad located on the front switch panel. The display will return to the **PROGRAM HOME SCREEN**.

If none of the five programming switches are pressed within 90 seconds during the setup of the dispenser, the programming of the function screen that is being set will be exited and the display will return to the **PROGRAM HOME SCREEN**.

PROGRAM HOME SCREEN



WARM TANK XXX°
HOT TANK XXX°

The screen above will be shown when the dispenser is ready for use. While the tank is heating, the water temperature will be displayed until the ready temperature is reached.

PROGRAMMING SWITCHES

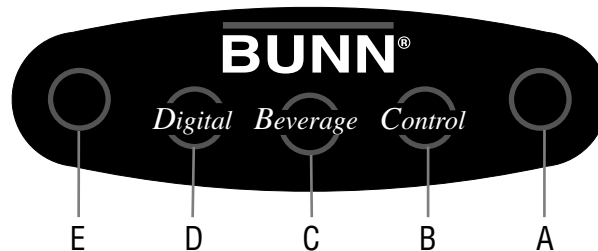

- A. Enter program mode and advance to next menu
- B. Increment display value positive
- C. Exit program mode
- D. Increment display value negative
- E. Return to previous menu

Using the menu-driven display (MAIN SCREEN) on the front of dispenser, the operator has the ability to alter or modify various functions of the dispenser. This allows for precise dispensing of various flavors of powdered products.

Programming of dispenser is achieved by entering a certain function, then, by use of programming switches, the operator can customize the dispensing process to their specifications.

To access the programming mode, and to scroll through different function screens, the programming switches shown are used. There are five of switches that will be used for setup of the dispenser.

PROGRAMMING THE DISPENSER (cont.)

NORMAL/PROGRAM/RINSE switch:

NORMAL: Allows all dispenser functions. Must be in this position for dispensing.

PROGRAM: Allows access to program menus using touch pad and LCD screen.

RINSE: Disables hopper motors. Pressing dispense button on front door will dispense dilution water and power whipper motor for ten seconds.

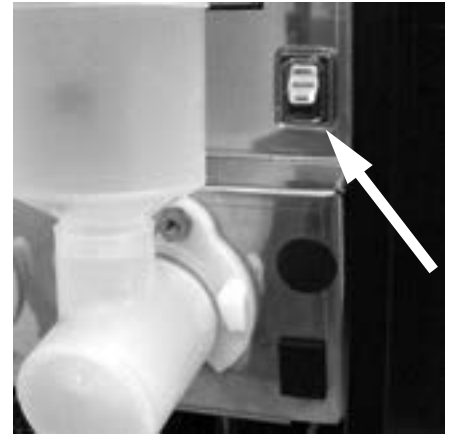

P3060

PROGRAMMING LOCKOUT SWITCH

This switch can be set to prevent access to the programming mode of the dispenser. Once all the correct settings are programmed, the operator can set the switch to the “ON” position to prohibit anyone from changing the settings.

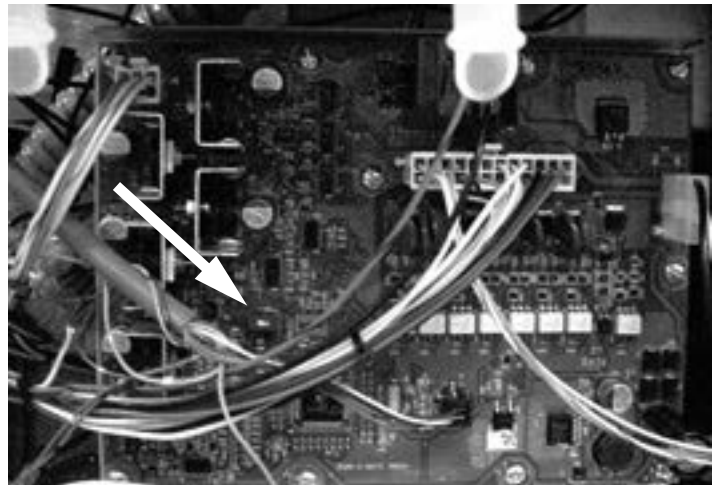

P3060

PROGRAMMING CUP SIZES - Portion Control Models

The cup size can be programmed in portion control models by “EXAMPLE” or “TIME”. Programming by EXAMPLE is manually pressing desired dispense button, then releasing when the desired cup size is attained. The time required to fill the cup will be stored in the controller memory when moving to the next menu. Programming by TIME is setting the actual dispense time in seconds for each cup size desired.

Place the “NORMAL/PROGRAM/RINSE” switch in the “PROGRAM” position. Press button A (page 8) below the BUNN logo on front of the door until the “SET CUP SIZE” menu is reached. (Refer to menu J, page 12) Press button D (page 8) to select programming by “EXAMPLE”. Place proper cup under dispense tip for station you desire to set. Press desired dispense button, then release when the cup is 3/4 full. If cup is not full enough, the dispense button can be pressed again to add additional beverage to the cup. If cup has reached desired level, press button B under “SAVE” to record the dispense time. If cup is overfilled, press button D under “REPEAT”. Empty cup and repeat the process.

If setting cup sizes by “TIME” is desired, press button B under “TIME” in the “SET CUP SIZE” menu. “HEAD 1 SM TIME” will be displayed, along with current time setting. Pressing either button D below (-) or button B below (+) will subtract or add time in .1 second increments. Each one second of time equals approximately 1.25 ounces of beverage at factory settings. When desired time is set, press button A to continue to next cup size.

When the desired cup sizes have been programmed, press button C to exit program menus, or press button A to move to the next menu. If button C was selected to exit the program mode, return the “NORMAL/PROGRAM/RINSE” switch to the “NORMAL” position to return to normal operation.

PROGRAMMING THE DISPENSER (cont.)

Press and release right switch (advance to next menu), "TANK TEMP XXX°" appears on screen.

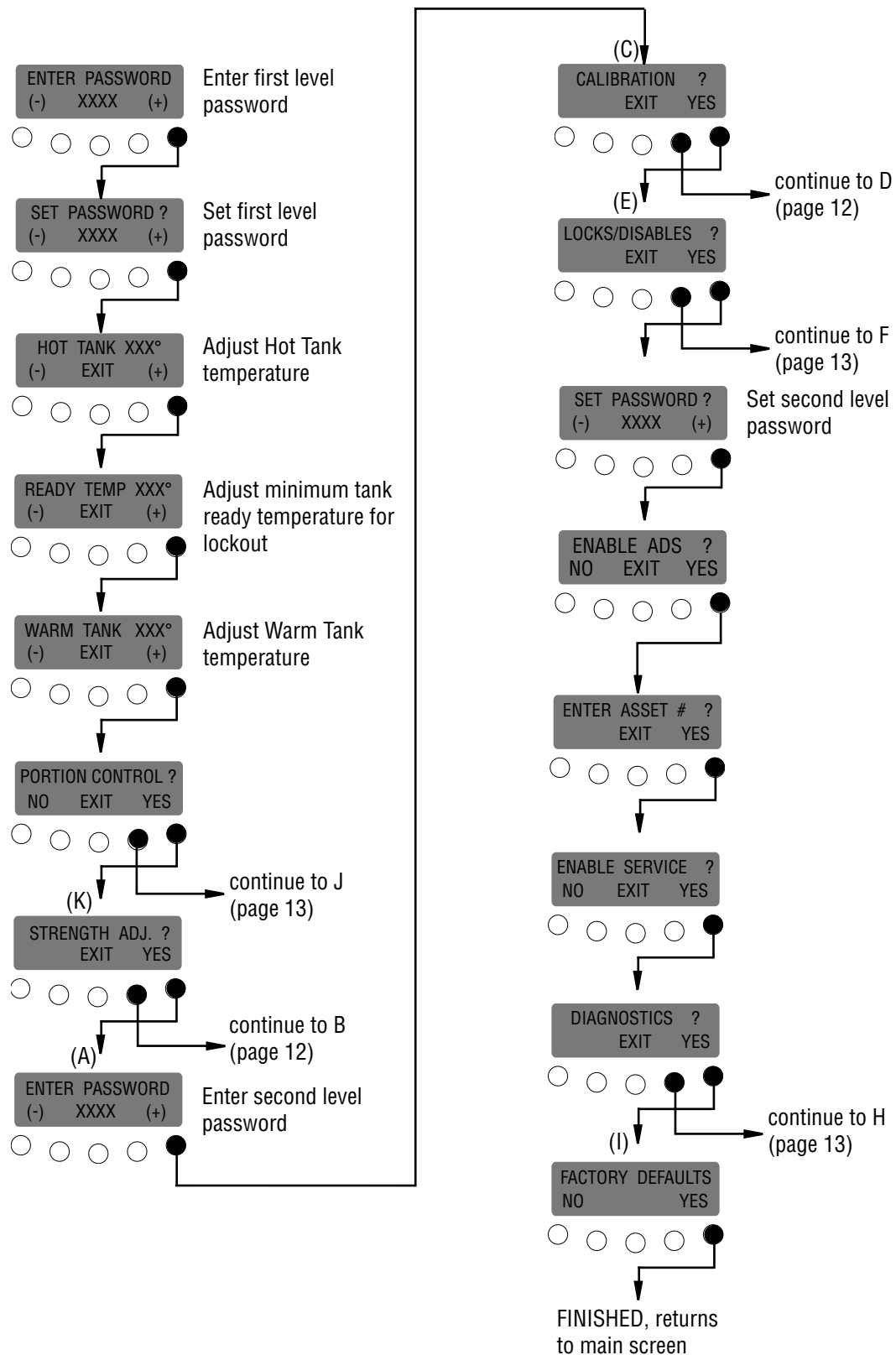

PROGRAMMING THE DISPENSER (cont.)

Adjust hopper
motor speed for
station selected

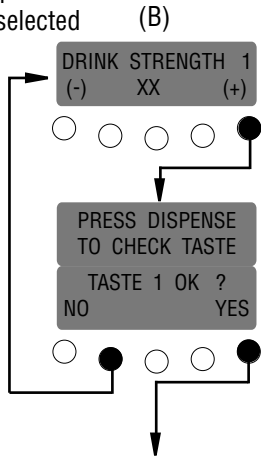

Goes to next station.
Returns to (A) (page
11) after last station.

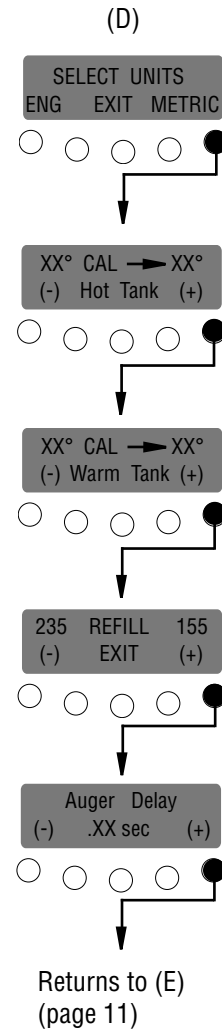

PROGRAMMING THE DISPENSER (cont.)

