

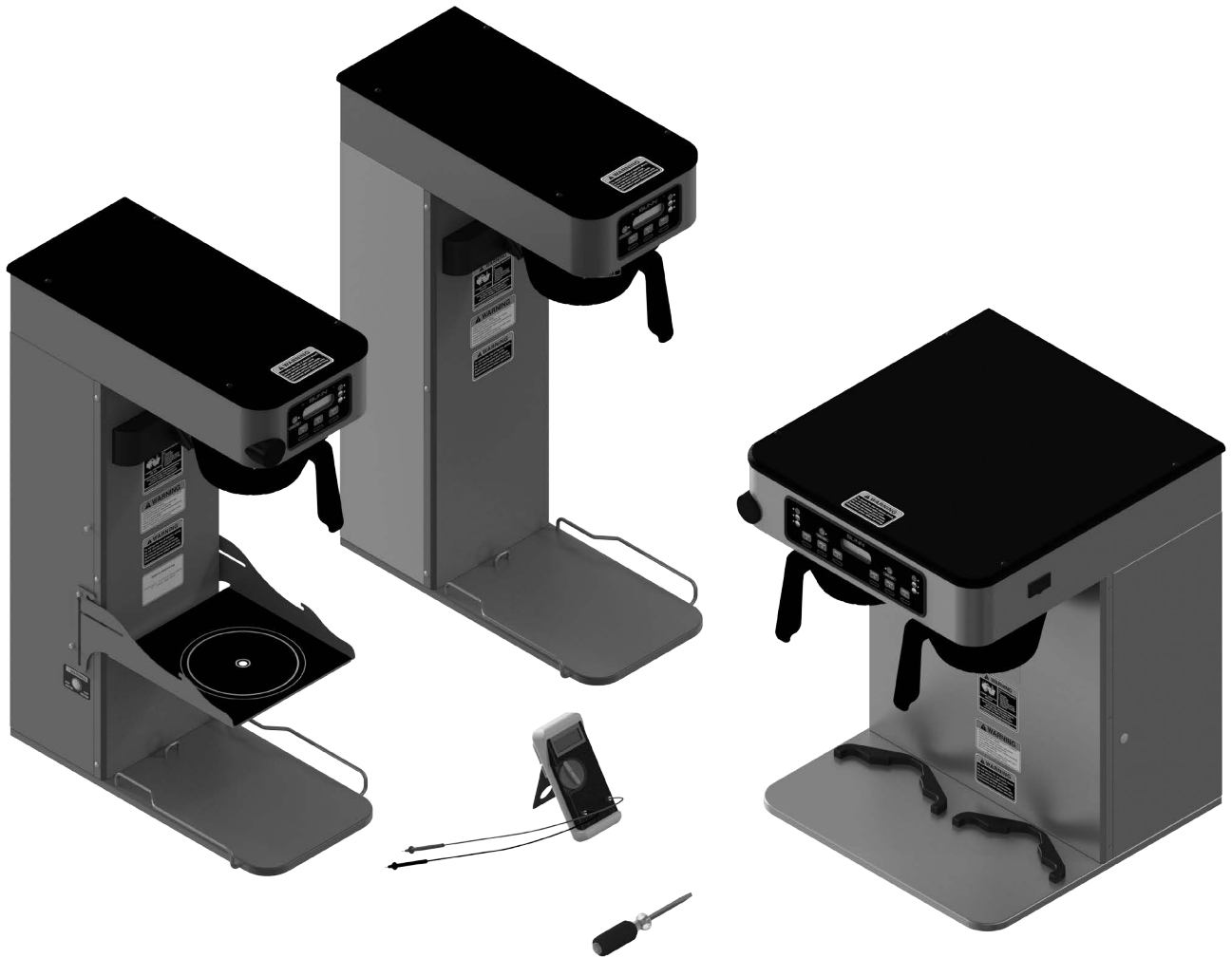

***ITB/ITCB/HV
ICB/TWIN
New Infusion Series®***



SERVICE & REPAIR MANUAL

BUNN-O-MATIC CORPORATION

POST OFFICE BOX 3227

SPRINGFIELD, ILLINOIS 62708-3227

PHONE: (217) 529-6601 FAX: (217) 529-6644



BUNN-O-MATIC COMMERCIAL PRODUCT WARRANTY

Bunn-O-Matic Corp. ("BUNN") warrants equipment manufactured by it as follows:

- 1) Airpots, thermal carafes, decanters, GPR servers, iced tea/coffee dispensers, MCR/MCP/MCA single cup brewers, thermal servers and ThermoFresh® servers (mechanical and digital) 1 year parts and 1 year labor.
- 2) All other equipment - 2 years parts and 1 year labor plus added warranties as specified below:
 - a) Electronic circuit and/or control boards - parts and labor for 3 years.
 - b) Compressors on refrigeration equipment - 5 years parts and 1 year labor.
 - c) Grinding burrs on coffee grinding equipment to grind coffee to meet original factory screen sieve analysis - parts and labor for 4 years or 40,000 pounds of coffee, whichever comes first.

These warranty periods run from the date of installation BUNN warrants that the equipment manufactured by it will be commercially free of defects in material and workmanship existing at the time of manufacture and appearing within the applicable warranty period. This warranty does not apply to any equipment, component or part that was not manufactured by BUNN or that, in BUNN's judgment, has been affected by misuse, neglect, alteration, improper installation or operation, improper maintenance or repair, non periodic cleaning and descaling, equipment failures related to poor water quality, damage or casualty. In addition, the warranty does not apply to replacement of items subject to normal use including but not limited to user replaceable parts such as seals and gaskets. This warranty is conditioned on the Buyer 1) giving BUNN prompt notice of any claim to be made under this warranty by telephone at (217) 529-6601 or by writing to Post Office Box 3227, Springfield, Illinois 62708-3227; 2) if requested by BUNN, shipping the defective equipment prepaid to an authorized BUNN service location; and 3) receiving prior authorization from BUNN that the defective equipment is under warranty.

THE FOREGOING WARRANTY IS EXCLUSIVE AND IS IN LIEU OF ANY OTHER WARRANTY, WRITTEN OR ORAL, EXPRESS OR IMPLIED, INCLUDING, BUT NOT LIMITED TO, ANY IMPLIED WARRANTY OF EITHER MERCHANTABILITY OR FITNESS FOR A PARTICULAR PURPOSE. The agents, dealers or employees of BUNN are not authorized to make modifications to this warranty or to make additional warranties that are binding on BUNN. Accordingly, statements by such individuals, whether oral or written, do not constitute warranties and should not be relied upon.

If BUNN determines in its sole discretion that the equipment does not conform to the warranty, BUNN, at its exclusive option while the equipment is under warranty, shall either 1) provide at no charge replacement parts and/or labor (during the applicable parts and labor warranty periods specified above) to repair the defective components, provided that this repair is done by a BUNN Authorized Service Representative; or 2) shall replace the equipment or refund the purchase price for the equipment.

THE BUYER'S REMEDY AGAINST BUNN FOR THE BREACH OF ANY OBLIGATION ARISING OUT OF THE SALE OF THIS EQUIPMENT, WHETHER DERIVED FROM WARRANTY OR OTHERWISE, SHALL BE LIMITED, AT BUNN'S SOLE OPTION AS SPECIFIED HEREIN, TO REPAIR, REPLACEMENT OR REFUND.

In no event shall BUNN be liable for any other damage or loss, including, but not limited to, lost profits, lost sales, loss of use of equipment, claims of Buyer's customers, cost of capital, cost of down time, cost of substitute equipment, facilities or services, or any other special, incidental or consequential damages.

392, A Partner You Can Count On, Air Infusion, AutoPOD, AXIOM, BrewLOGIC, BrewMETER, Brew Better Not Bitter, BrewWISE, BrewWIZARD, BUNN Espresso, BUNN Family Gourmet, BUNN Gourmet, BUNN Pour-O-Matic, BUNN, BUNN with the stylized red line, BUNNlink, Bunn-O-Matic, Bunn-O-Matic, BUNNserve, BUNNSERVE with the stylized wrench design, Cool Froth, DBC, Dr. Brew stylized Dr. design, Dual, Easy Pour, EasyClear, EasyGard, FlavorGard, Gourmet Ice, Gourmet Juice, High Intensity, iMIX, Infusion Series, Intellisteam, My Café, Phase Brew, PowerLogic, Quality Beverage Equipment Worldwide, Respect Earth, Respect Earth with the stylized leaf and coffee cherry design, Safety-Fresh, savemycoffee.com, Scale-Pro, Silver Series, Single, Smart Funnel, Smart Hopper, SmartWAVE, Soft Heat, SplashGard, The Mark of Quality in Beverage Equipment Worldwide, ThermoFresh, Titan, trifacta, TRIFECTA (stylized logo), Velocity Brew, Air Brew, Beverage Bar Creator, Beverage Profit Calculator, Brew better, not bitter., Build-A-Drink, BUNNSource, Coffee At Its Best, Cyclonic Heating System, Daypart, Digital Brewer Control, Element, Milk Texturing Fusion, Nothing Brews Like a BUNN, Picture Prompted Cleaning, Pouring Profits, Signature Series, Sure Tamp, Tea At Its Best, The Horizontal Red Line, Ultra are either trademarks or registered trademarks of Bunn-O-Matic Corporation. The commercial trifacta® brewer housing configuration is a trademark of Bunn-O-Matic Corporation.

CONTENTS

Warranty	2
Contents.....	3
Troubleshooting	4
Diagnostic Displays.....	9
Access	10
Control Board.....	11
Membrane Switch	13
Bypass Valves	14
Brew Valves	15
Refill Valves	16
Tank Heaters	17
Limit Thermostat.....	18
Temperature Probe.....	19
DV Selector Switch	21
On/Off Switch.....	22
Schematic Wiring Diagrams.....	23

TROUBLESHOOTING

A troubleshooting guide is provided to suggest probable causes and remedies for the most likely problems encountered. If the problem remains after exhausting the troubleshooting steps, contact the Bunn-O-Matic Technical Service Department.

- Inspection, testing, and repair of electrical equipment should be performed only by qualified service personnel.
- All electronic components have ac line voltage and some have low voltage dc potential on their terminals. Shorting of terminals or the application of external voltages may result in board failure.
- Intermittent operation of electronic circuit boards is unlikely. Board failure will normally be permanent. If an intermittent condition is encountered, the cause will likely be a switch contact or a loose connection at a terminal or crimp.
- Solenoid removal requires interrupting the water supply to the valve. Damage may result if solenoids are energized for more than ten minutes without a supply of water.
- The use of two wrenches is recommended whenever plumbing fittings are tightened or loosened. This will help to avoid twists and kinks in the tubing.
- Make certain that all plumbing connections are sealed and electrical connections tight and isolated.
- This brewer is heated at all times. Keep away from combustibles.

WARNING

- **Exercise extreme caution when servicing electrical equipment.**
- **Unplug the brewer when servicing, except when electrical tests are specified.**
- **Follow recommended service procedures.**
- **Replace all protective shields or safety notices.**

Before troubleshooting this brewer, check for the following:

Control Boards

1. Make sure ribbon cable is properly attached to the control board (ALL PINS INSERTED INTO PLUG).
2. Make sure before servicing brewer that voltage is present at control board.
3. Press any warmer switch or observe if any indicator lights are glowing on the control panel. If so, proceed with testing. If not, check for voltage across pins 9 & 11 of the 14 pin connector (black and white wires). If voltage is present, replace the control board. If voltage is not present, check wiring and voltage across terminal block (black and white). Correct the problem and retest before proceeding with testing.

NOTE: *In the event of board replacement, technician will need to re-program customer's settings and/or recipes, as well as re-calibrate the temperature probe in program level 2 and re-enter the serial number in level 2.*

TROUBLESHOOTING (cont.)

REFILL CIRCUIT

PROBLEM	PROBABLE CAUSE	REMEDY
Will not refill	1. Power off to brewer	Press ENABLE BREW switch on control panel to determine if power is ON.
	2. Water shut off	Make sure water is ON.
	3. Error Message	Brewer has shut down due to malfunction (See Diagnostic Section in this manual).
	4.ON/OFF Switch (If equipped)	Make sure ON/OFF Switch is "ON" and indicator is lit.
	5. Lime build up on Probe(s)	Remove the Level Probe(s) and check for lime deposit on tip. Clean and reinstall.
	6. Refill Valve or Control Board	Check valve.
Refill does not shut off Power "ON"	1. Lime build up on probe	Remove Level Probe and check for lime deposits on tip. Clean and reinstall.
	2. Water Level Sensing System	Replace control board
	3. Refill valve or control board	Check valve.
Refill does not shut off Power "OFF"	1. Refill valve	Clean or replace valve as needed.

TROUBLESHOOTING (cont.)

HEATING CIRCUIT

PROBLEM

PROBABLE CAUSE

REMEDY

Water does not heat to proper temperature

IMPORTANT: Make sure no temperature tests are taken before the display reads ready. Tank temperature must be stabilized before readings are taken.

1. Display's error message

Brewer has shut down due to malfunction. See Diagnostics.

2. Water not touching main (short) level probe

Remove level probe and grommet. Look into hole on tank lid. Water must be within approximately one inch from top of tank.

3. Water Level Probe Sensing System

Check refill circuit. Heaters will not turn on if water is not grounding level probe.

4. Temperature Probe

Check/replace

5. Limit Thermostat or TCO

Check/replace

6. Tank Heater

Check/replace

7. Off Board Triac

Check/replace

Spitting or excessive steaming (cont.)

1. Lime build up on temperature probe, tank or tank heater

Inspect probe and tank assembly for excessive lime deposits. Delime as required.

2. Temperature Probe

Check/replace

3. Control Board

Check/replace

Brewer is making unusual noises

1. Plumbing lines

Plumbing lines should not rest on the counter top.

2. Water supply

The brewer must be connected to a cold water supply.

3. Lime build up

Remove the tank lid and clean inside of tank with a deliming agent, if necessary.

TROUBLESHOOTING (cont.)
BREWING CIRCUIT

PROBLEM	PROBABLE CAUSE	REMEDY
Brew cycle will not start	1. Display's error message	Brewer has shut down due to malfunction. See Diagnostics.
	2. No water	Water lines and valves to the brewer must be open.
	3. No power or incorrect voltage to the brewer	Check for voltage across the terminals at the terminal block.
	4. ON/OFF switch not in the "ON" position	The indicator lamp must be lit
	5. Low water temperature (Brew lockout is enabled)	Allow brewer to heat until ready, or disable the brew lockout feature.
	6. Water not touching refill probe inside tank	Water must be in contact with refill probe before brew cycle will start.
	7. Membrane Switch	Check/replace
	8. Dispense valve	Check/replace
	9. Control board	Check/replace
Consistently low beverage level in the dispenser or beverage overflows dispenser	1. Brew volume NOTE: Volume adjustments must be made with sprayhead installed.	Inspect the dispense valve and sprayhead for excessive lime deposits. Delime as required.
	2. Lime build up	Remove dispense valve and clear any obstructions. Rebuild or replace valve if necessary. (See page 15)
	3. Dispense Valve	Check/replace

TROUBLESHOOTING (cont.)

BREWING CIRCUIT (cont.)

PROBLEM

PROBABLE CAUSE

REMEDY

Dripping from sprayhead

1. Lime build up

Inspect the tank assembly for excessive lime deposits. Delime as required.

2. Dispense valve

Check/replace

Weak beverage

1. Sprayhead

A clean sprayhead must be used for proper extraction.

2. Water temperature

Place an empty brew funnel on an empty decanter beneath the sprayhead. Initiate brew cycle and check the water temperature immediately below the sprayhead with a thermometer. The reading must not be less than 195°F (91°C). Adjust the temperature setting to increase the water temperature. Refer to Initial Set-up instructions.

3. Filter type

BUNN® paper filters must be used for proper extraction.

4. Coffee grind

A fine drip or grind must be used for proper extraction.

5. Funnel loading

The BUNN® paper filter must be centered in the funnel and the bed of grounds leveled by shaking gently.

Dry coffee grounds remain in the funnel

1. Sprayhead

Make sure sprayhead is present and holes are clear and unobstructed.

2. Funnel loading

The BUNN® paper filter must be centered in the funnel and the bed of grounds leveled by shaking gently.

Low beverage serving temperature

1. Thermal server/airpot not preheated before brew cycle

Preheat server

DIAGNOSTICS

MESSAGE	PROBABLE CAUSE	REMEDY
Temperature Too Low	1. Water temperature in the tank does not meet the ready temperature.	A) Wait for the brewer to heat to the proper temperature. B) Disable the BREW LOCKOUT function. Refer to programming section for procedure.
Heating Time Too Long	1. Tank Heater failure. 2. Control Board/Thermistor failure	Replace or repair as needed Replace or repair as needed
Fill Time Too Long	1. Water shut off to brewer 2. Supply line too small or obstructed 3. Inlet Solenoid failure 4. Control Board Failure 5. ON/OFF switch is OFF	Check water supply shut-off Replace or repair as needed Replace or repair as needed Replace or repair as needed Turn switch ON
Temp Sensor Out Of Range, Check For Bad Connections	1. Temperature Sensor Probe open	Replace or repair as needed
Temp Sensor Out Of Range, Check Wire For Shorts	1. Temperature Sensor Probe wire(s) shorted	Replace or repair as needed

COMPONENT ACCESS

This section provides procedures for testing and replacing various major components used in this brewer should service become necessary. Refer to Troubleshooting for assistance in determining the cause of any problem.

WARNING - Inspection, testing, and repair of electrical equipment should be performed only by qualified service personnel. The brewer should be unplugged when servicing, except when electrical tests are required and the test procedure specifically states to plug in the brewer.

WARNING - Disconnect the brewer from the power source before the removal of any panel or the replacement of any component.

All components are accessible by the removal of the top cover or front access panel.

Refer to wiring diagrams at the back of this manual when reconnecting wires.



FIG. 10-2 ITB/ITCB COMPONENT ACCESS



FIG. 10-1 ICB/ITCB HV COMPONENT ACCESS



FIG. 10-3 ICB/ITCB HV TWIN COMPONENT ACCESS

CONTROL BOARD

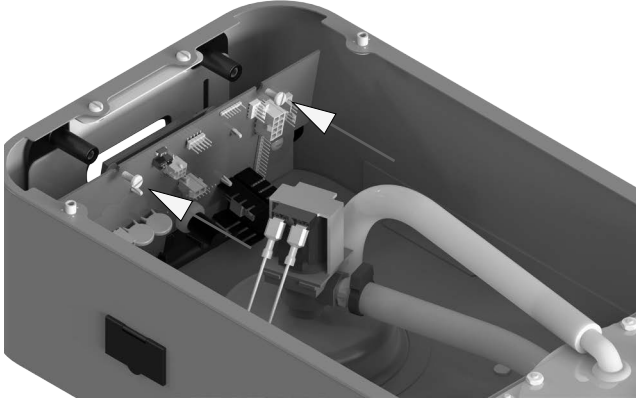

FIG. 11-1 CONTROL BOARD

Location:

The Control Board is located inside the top cover behind the front face plate.

Test Procedures:

The test procedures for the control board will vary depending upon the problems experienced by the brewer. Refer to the Troubleshooting section which is divided into three sections, Refill Circuit, Heating Circuit, and Brewing Circuit.

Check for Power to board:

1. Insert one meter lead in J17-pin 9 and the other lead in J17-pin 11.
2. With the power connected to brewer, the voltage reading to the board should be the line voltage rated for that model.

If no voltage is present, check wiring to the board. If voltage is present, and brewer does not power on, go to step 3

3. Check for line voltage at J15-1 BLK to J15-2 WHI.

If no voltage is present, replace the control board. If voltage is present, go to step 4

4. Check for 12VAC at J15-4 to J15-2 Yellow wires.

If no voltage is present, replace the transformer. If voltage is present, and brewer does not power on, replace the control board.

Removal and Replacement:

1. Disconnect brewer from power source.
2. Disconnect the wires from the relay on the control board.
3. Disconnect all of the connectors from the control board.
4. Remove the two screws securing the control board to the faceplate.
5. Tilt the control board inward to clear the display section.
6. Place the bottom edge of the new control board in the cradle, tilt the board forward, and secure with the two nuts to the hood.
7. Re-install connectors.

Faceplate Removal and Replacement:

1. Disconnect brewer from power source.
2. Disconnect the ribbon cable from the control board.
3. **Models with faucet:** Drain tank to below faucet outlet fitting. Remove hose, nut and washer from faucet. Remove faucet assembly.
4. Remove the two screws and two nuts securing the face plate to the hood.
5. Carefully pull the ribbon cable through the front opening of the hood.
6. Installation is the reverse order.

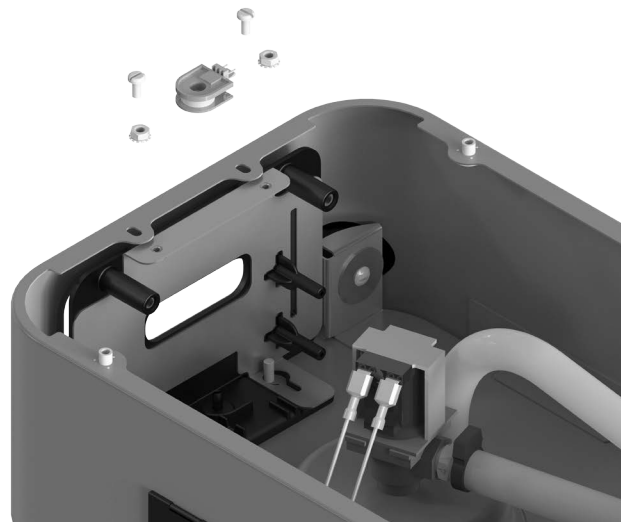

FIG. 11-2 FACEPLATE REMOVAL

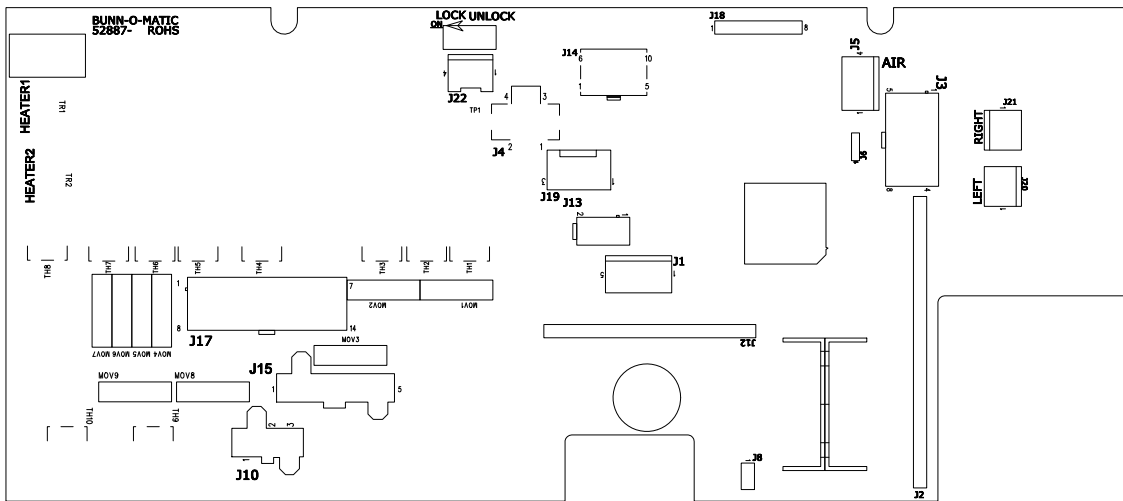

FIG. 12 TRIAC MAP

CONTROL BOARD-ICB TWIN/ITCB DV HV/ITCB TWIN HV TRIAC MAP

Triac:	Load Component:	Connector:
TH1/MOV3/BR2	Left Funnel Lock	J17-13/J17-14
TH2/MOV1	Refill solenoid	J17-5
TH3/MOV2/BR3	Right Funnel Lock	J17-6/J17-7
OFFBOARD	Tank Heaters	TR1/TR2
TH4/MOV6	Left Brew Solenoid	J17-3
TH5/MOV4	Right Brew Solenoid	J17-2
TH6/MOV5	Left Bypass Solenoid	J17-1
TH7/MOV7	Right Bypass Solenoid	J17-10

CONTROL BOARD-ICB/ITCB TRIAC MAP

Triac:	Load Component:	Connector:
TH1/MOV3/BR2	Funnel Lock	J17-13/J17-14
TH2/MOV1	Refill solenoid	J17-5
TH4/MOV6	Brew Solenoid	J17-3
OFFBOARD	Tank Heater(s)	TR1
TH6/MOV5	Dilution or Bypass Solenoid	J17-1

CONTROL BOARD-ITB TRIAC MAP

Triac:	Load Component:	Connector:
TH6/MOV5	Main or Left Dilution	J17-1
TH2/MOV1	Refill solenoid	J17-5
TH4/MOV6	Brew Solenoid	J17-3
TH7/MOV7	Right Dilution	J17-10
TH9/MOV8	Sweetner	J10-3
OFFBOARD	Tank Heater	TR1
TH1/MOV3/BR2	Funnel Lock	J17-13/J17-14

MEMBRANE SWITCH

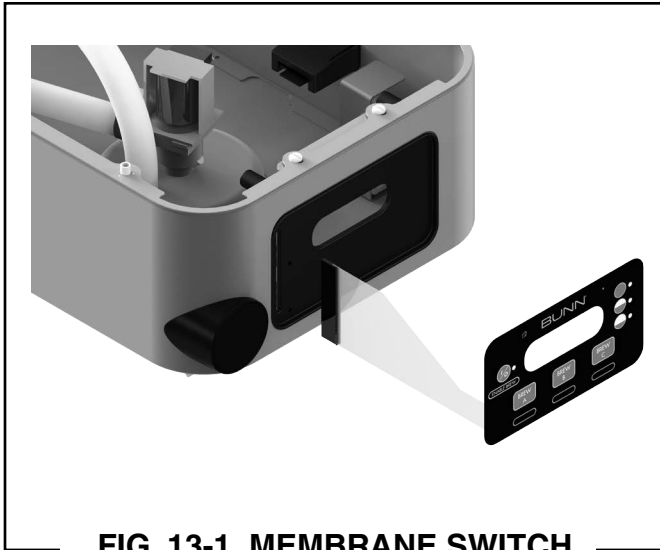

FIG. 13-1 MEMBRANE SWITCH

Location:

The Membrane Switch is located on the front face plate.

Test Procedures:

There are two methods for testing the membrane switch. The easiest method is to use the built in test mode. Refer to the Programming Section for Service Tools/Test Switches. If for some reason you can't get into the program modes, or brewer won't power up, you can test it with an ohmmeter or continuity tester. Refer to the schematic to trace the appropriate pins.

NOTE: Pin 22 is the static shield & will not provide a reading to the other pins. There are two commons in this circuit, pins 9 & 10. Disconnect brewer from power source before disconnecting ribbon cable from control board.

Removal and Replacement:

1. Disconnect the ribbon cable from the 22-pin connector on the control board.
2. Gently peel the membrane switch from the front face plate assembly.
4. Remove any adhesive that remains on the front face plate.
5. Remove the adhesive backing from the new membrane switch. Insert the ribbon cable through the slot in the front face plate and apply the membrane switch to the front face plate.
6. Connect the ribbon cable to the 22-pin connector on the control board making sure every pin on the control board is inserted into the ribbon cable connector.

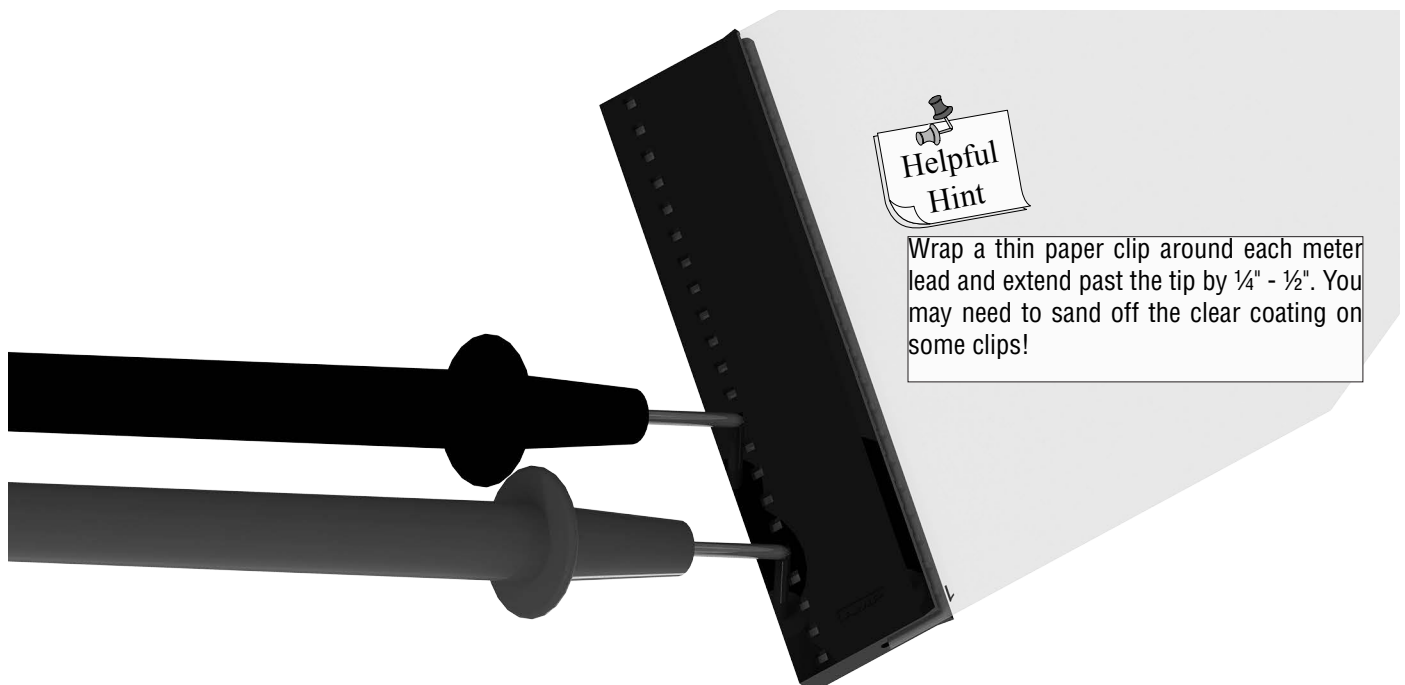

FIG. 13-2 MEMBRANE SWITCH CONTINUITY

BYPASS VALVE ON ALL ICB's

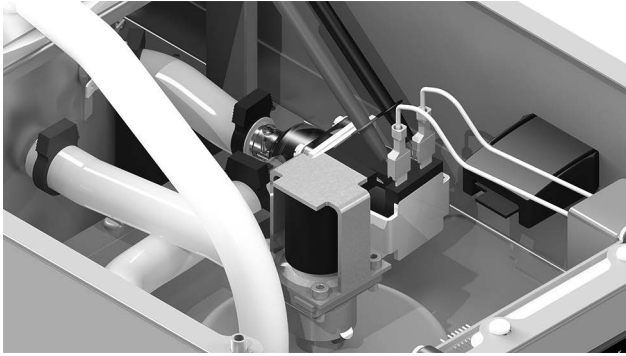

FIG. 14-1 BYPASS VALVE

Location:

The bypass valve is located inside the top cover behind the front face plate.

Test Procedures:

1. Refer to the Programming Section for Service Tools/ Test Outputs/Bypass Valve.
2. Be sure brew funnel & server are in place before activating valve.
3. Check the valve for coil action. Turn on the valve with the test mode. Listen carefully in the vicinity of the brew valve for a click as the coil pulls the plunger in.

If no sound is heard as described, proceed to #4.

If the sound is heard as described, there may be a blockage in the valve, hose, tank, or sprayhead. Disconnect the brewer from the power source. Remove the valve and inspect for blockage, and de-lime all related areas.

4. Connect the voltmeter leads to the coil terminals. Turn on the valve with the test mode.

The indication will be 2-3VAC off, 120VAC on. Set the meter to DC volts. The indication should be 150-160VDC when off, 0V when on. If the polarity of meter leads are reversed, reading will indicate -150-160VDC. *(Double these readings for 240 volt coils)*

If voltage is present as described, but no coil action is observed, brew valve is defective. Replace valve and test again to verify repair.

If voltage is not present as described, refer to Wiring Diagrams and check the brewer wiring harness. Also check the control board and switch for proper operation.

Removal and Replacement:

1. Disconnect the brewer from the power source.
2. Disconnect wires from the valve.
3. Drain enough water from the tank so the water level is below the outlet.
4. Remove hoses from the valve.
5. Remove the two #8-32 nuts securing the valve to the sprayhead panel.
6. Install new valve using the two #8-32 nuts.
7. Reconnect hoses to the valve and secure in place with clamps.

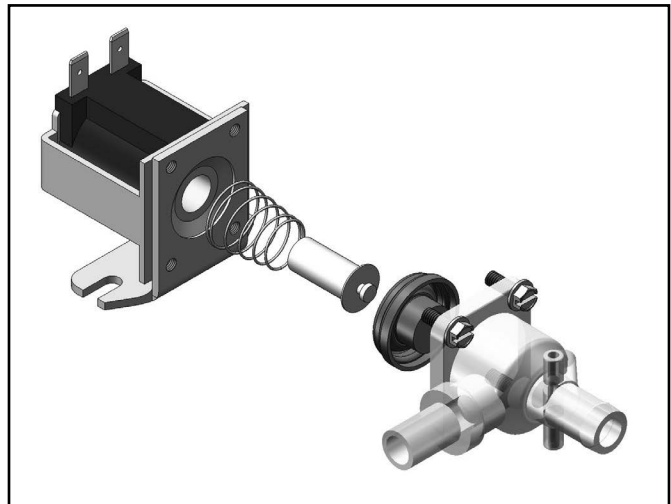

FIG. 14-2 EXPLODED VIEW



Due to the internally rectified coil, do not attempt to test this type of coil with an ohmmeter. The reading will be open or very high resistance, depending on the polarity of your meter leads.

BREW VALVE

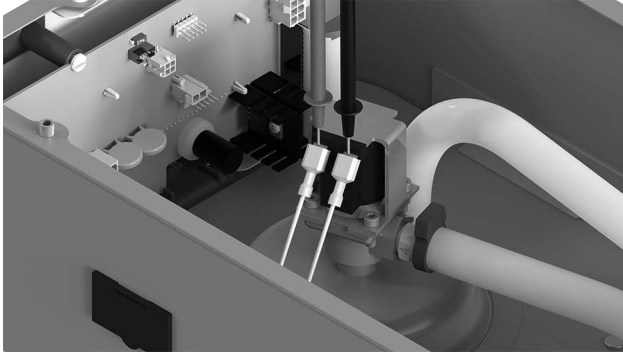

FIG. 15-1 BREW VALVE

Location:

The brew valve is located inside the top cover behind the front face plate.

Test Procedures:

1. Refer to the Programming Section for Service Tools/ Test Outputs/Brew Valve.
2. Be sure brew funnel & server are in place before activating valve.
3. Check the valve for coil action. Turn on the valve with the test mode. Listen carefully in the vicinity of the brew valve for a click as the coil pulls the plunger in.

If no sound is heard as described, proceed to #4.

If the sound is heard as described, there may be a blockage in the valve, hose, tank, or sprayhead. Disconnect the brewer from the power source. Remove the valve and inspect for blockage, and de-lime all related areas.

4. Connect the voltmeter leads to the coil terminals. Turn on the valve with the test mode.

The indication will be 2-3VAC off, 120VAC on. Set the meter to DC volts. The indication should be 150-160VDC when off, 0V when on. If the polarity of meter leads are reversed, reading will indicate -150-160VDC. *(Double these readings for 240 volt coils)*

If voltage is present as described, but no coil action is observed, valve is defective. Replace valve and test again to verify repair.

If voltage is not present as described, refer to Wiring Diagrams and check the brewer wiring harness. Also check the control board and membrane switch for proper operation.

Removal and Replacement:

1. Disconnect the brewer from the power source.
2. Disconnect wires from the valve.
3. Drain enough water from the tank so the water level is below the outlet.
4. Remove sprayhead and hose from the valve.
5. Remove the nut securing the valve to the sprayhead panel.
6. Install new valve using the nut from step 5.
7. Reinstall sprayhead and hose to the valve and secure in place with clamps.

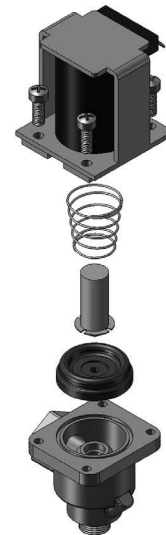

FIG. 15-2 BREW VALVE



Due to the internally rectified coil, do not attempt to test this type of coil with an ohmmeter. The reading will be open or very high resistance, depending on the polarity of your meter leads.

REFILL VALVES

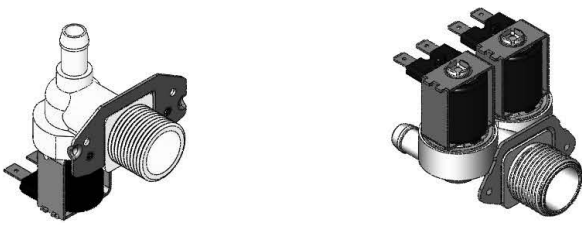

FIG. 16-1 REFILL VALVES

Location:

The refill valve is located inside the front of the brewer.

Test Procedures:

1. Enter programming level 2, scroll to "Service Tools" then scroll to "Refill Valve".
2. *Briefly* activate the refill valve in the test mode. With a voltmeter, check the voltage across the coil wires.
3. The indication must be 120 volts ac for two wire 120 volt models and three wire 120/208 -240 volt models or 230 volts ac for two wire 230 volt models.

If voltage is present, proceed to # 4.

If voltage is not present, refer to Wiring Diagrams and check main wiring harness. If harness checks ok, replace control board.

4. Check the refill valve for coil action. *Briefly* activate the refill valve in the test mode and listen carefully near the refill valve for a "clicking" sound as the magnetic coil pulls the plunger in.

If the sound is heard as described and water will not pass through the refill valve, there may be a blockage in the water line before the refill valve or, the solenoid valve may require inspection for wear, and removal of waterborne particles.

If the sound is not heard as described, proceed to # 5.

5. Disconnect the brewer from the power source. 6. Check for resistance across the coil terminals (200 Ω -2k Ω depending on which coil is being checked).

If resistance is not present as described, replace the refill valve.

If resistance is present as described, check for debris in the valve.

Removal and Replacement:

1. Remove both wires from the refill valve.
2. Verify that the white shutoff clamp between valve and tank is squeezed shut.

3. Disconnect both water lines at the valve.
4. Remove the two screws securing the valve to the component mounting bracket.
5. Using the two screws, install the new valve to the component mounting bracket.
6. Securely fasten the water lines to the valve.
7. Refer to wiring diagrams when reconnecting the wires.
8. Install access panels and covers and refer to Initial Set-up for refill and operation.

ICB & ITB

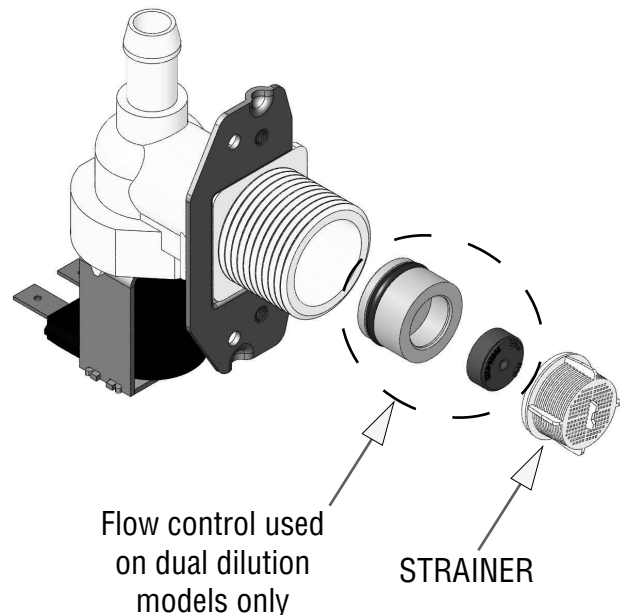

ITCB & ITB-DD

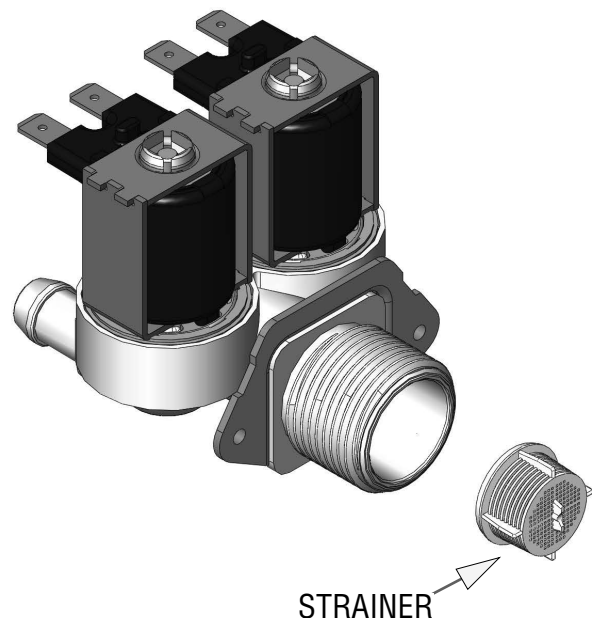

TANK HEATERS

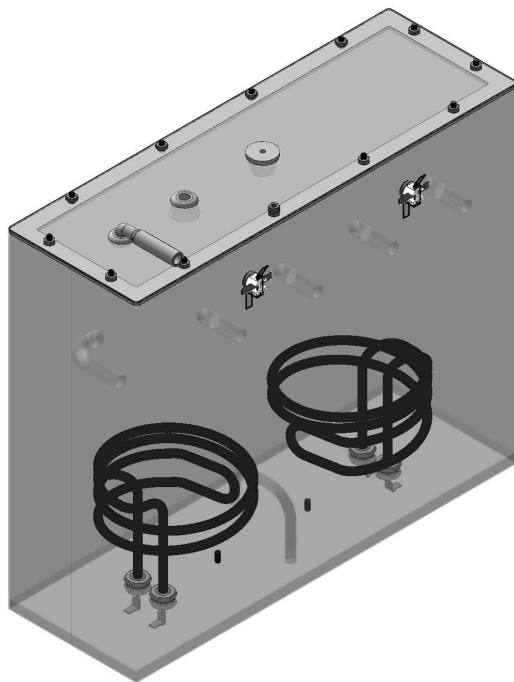

FIG. 17-1 ICB TWIN TANK HEATERS

Location:

The tank heaters are located inside the tank and secured to the tank bottom.

Test Procedures:

1. With a voltmeter, check voltage across the white wire (120V Models) or red wire (120/208-240V Models) from the terminal block and black wire from the control board. Connect brewer to the power source. The indication must be 120 volts ac for two wire 120 volt models or 208-240 volts ac for three wire 120/208-240 volt models (during a heating cycle).
2. Disconnect the brewer from the power source.

If voltage is present as described, proceed to #3.

If voltage is not present as described, refer to the Wiring Diagrams and check wiring harness.

3. Disconnect the wires from the tank heater terminals.
4. Check resistance value across tank heater terminals and compare to chart.

If resistance is present as described, reconnect the wires, the tank heater is ok.

If resistance is not present as described, replace the tank heater.

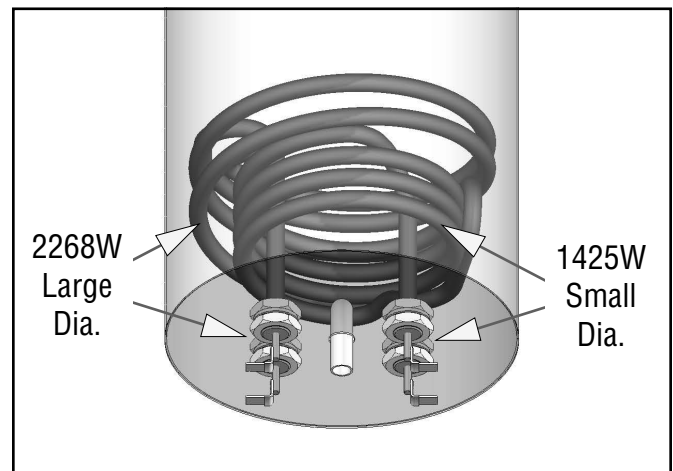

FIG. 17-2 DV TANK HEATERS

HEATER	RESISTANCE
1425W-120V	9.5-11.0 Ω
3500W-240V	15.1-17.6 Ω
1680W-120V	7.9-9.2 Ω
1800W-120V	7.4-8.7 Ω
2268W-120V	5.9-6.9 Ω
3000W-208V	12.9-15.1 Ω
3000W-240V	17.9-20.7 Ω
3500W-200V	10.5-12.2 Ω
TERMINAL TO SHEATH - INFINITE (OPEN)	

NOTE- If any resistance is read between sheath and either terminal, remove and inspect heater for cracks in the sheath.

Removal and Replacement:

1. Remove the top cover and front access panel as previously described.
2. Drain water from the tank.
3. Disconnect all the hoses from the tank.
4. Remove the temperature probe from the grommet in the tank lid.
5. Remove the level probe from it's grommet.
6. Disconnect the green wire from the tank lid.
7. Disconnect the wires from tank heater terminals.
8. Remove the nuts securing the tank lid to the tank.
9. Remove the hex nuts securing the tank heater to the bottom of the tank. Remove tank heater(s) with gaskets and discard.
10. Install new tank heater(s) with gaskets to the bottom of the tank and secure with two hex nuts.
11. Install tank lid and secure with nuts.
12. Reconnect the wires to tank heater terminals.

LIMIT THERMOSTAT

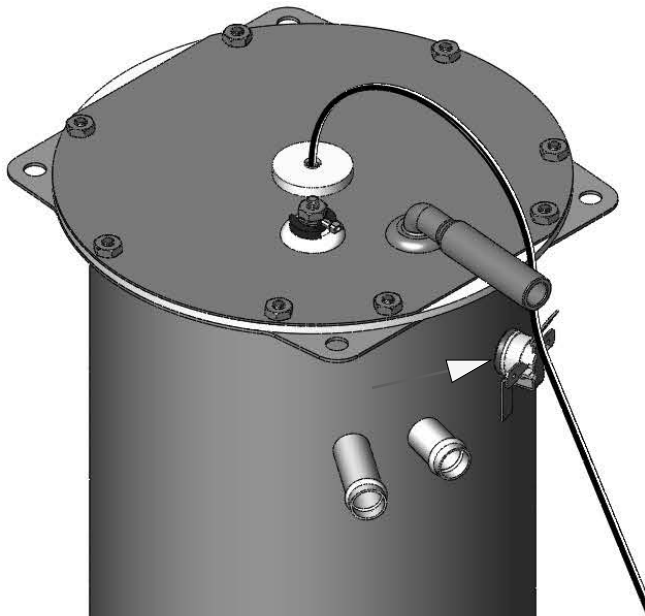

FIG. 18-1 LIMIT THERMOSTAT

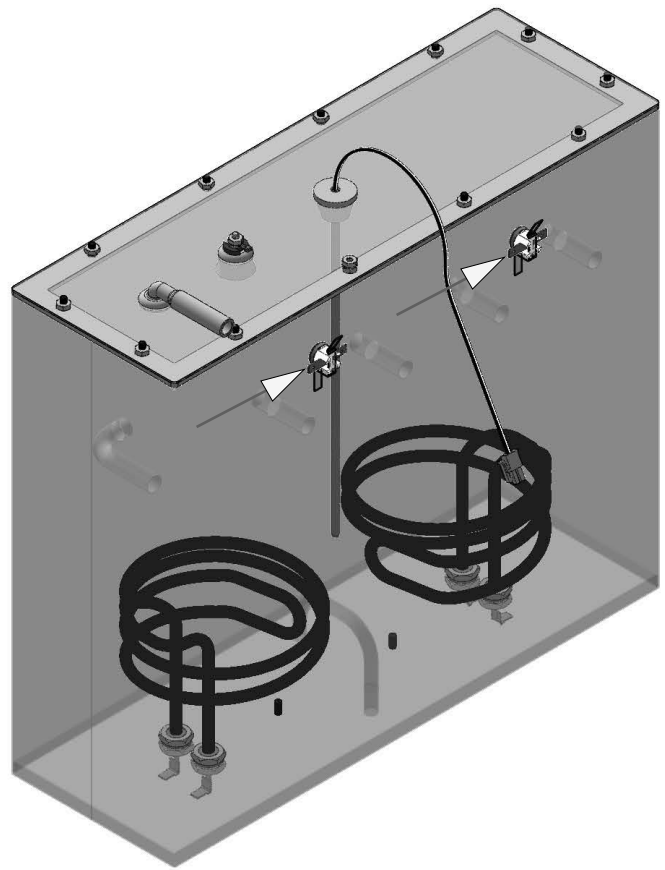

FIG. 18-2 LIMIT THERMOSTATS

Location:

The limit thermostat is located on the tank lid (on the front of the tank on twins).

Test Procedures:

1. Disconnect the brewer from the power source and allow to cool.
2. Disconnect the wires from the limit thermostat.
3. With an ohmmeter, check for continuity across the limit thermostat terminals.

If continuity is present as described, the limit thermostat is operating properly.

If continuity is not present as described, replace the limit thermostat.

Removal and Replacement:

1. Remove the wires from limit thermostat terminals.
2. Carefully slide the limit thermostat out from under the retaining clip and remove limit thermostat.
3. Carefully slide the new limit thermostat into the retaining clip. Ensure the metal face has good contact with tank.

TEMPERATURE PROBE

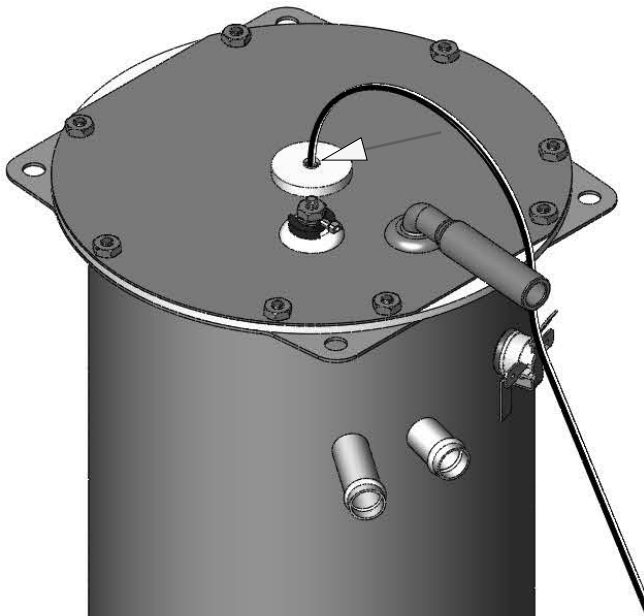

FIG. 19-1 TEMPERATURE PROBE

Location:

The temperature probe is inserted through the tank lid assembly.

Test Procedures:

1. Disconnect the brewer from the power source.
2. With a DC voltmeter, check voltage across the two wires at J13 (J3 on ITB) on control board (black probe to black wire, red probe to white wire refer to FIG 19-2). Connect the brewer to the power source. The indication should be between 4vdc (cool) to 1vdc at ready temperature.
3. Disconnect the brewer from the power source.

If voltage is present as described, circuit is working correctly.

If voltage is not present as described, proceed to #4.

4. Disconnect temperature probe from J9 on control board. Check the resistance across the two terminals of the temperature probe. The indication should be between 10.5K Ω cool to 870 Ω at ready temperature.

If resistance is to specification, replace the control board.

If resistance is not to specification, replace the temperature probe.

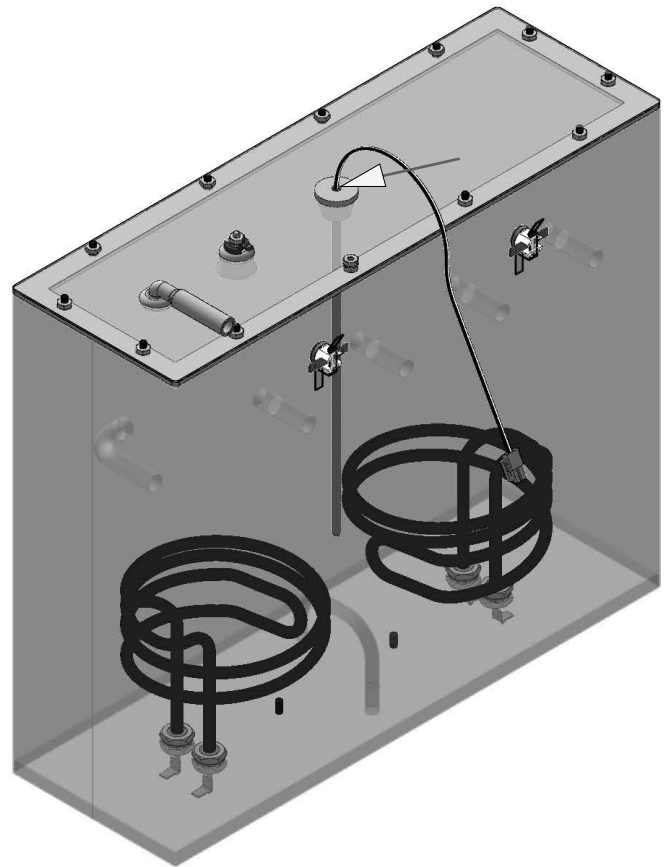

FIG. 19-2 TEMPERATURE PROBE

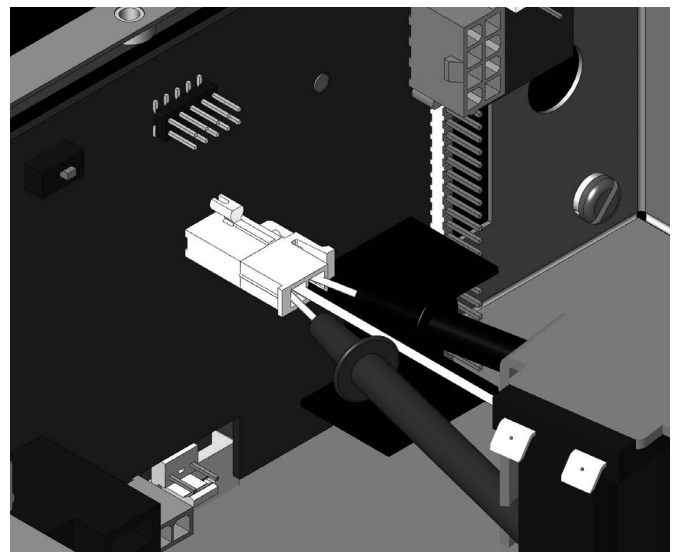

FIG. 19-3 TESTING TEMPERATURE PROBE

Removal and Replacement:

CONTINUED

TEMPERATURE PROBE

Removal and Replacement:

1. Disconnect the brewer from the power source.
2. Disconnect the two pin connector from J9 on control board.
3. Pull temperature probe out of it's grommet.
4. Install in reverse order.

Calibration:

1. Remove silicon vent fitting from tank lid.
2. Insert a digital temp probe through the exposed vent hole in tank lid to the same depth as the factory temp probe. FIG 20-1.

3. Press and hold the "Hidden" button until display reads "CAL TEMPERATURE SENSOR?" "NO/YES"
4. Select "YES". The display should show something similar to the screen below (FIG 20-2).

NOTE: Variables such as tank set temperature could show different numbers than the example shown here. Tank must be at it's ready temp before calibrating.

5. Press the + (Control) button to increase or - (Digital) button to decrease temperature reading until it matches the reading on the thermometer.
6. Exit program mode, remove thermometer, and install vent fitting. Calibration is complete

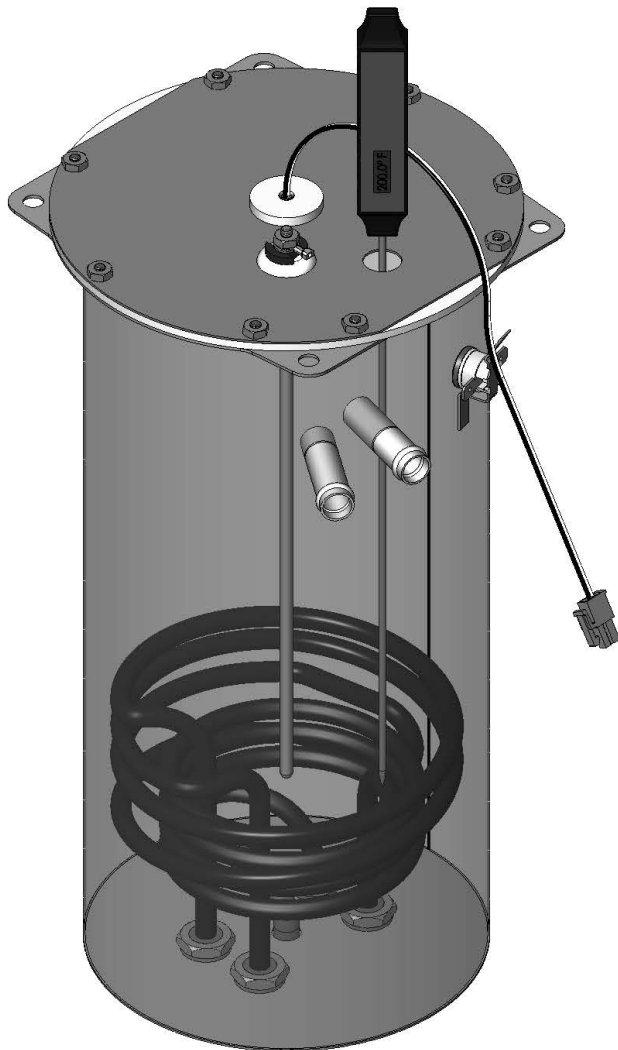

FIG. 20-1 CALIBRATE TEMP PROBE

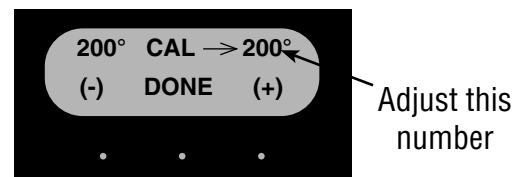

FIG. 20-2 CALIBRATION

VOLTAGE SELECTOR SWITCH

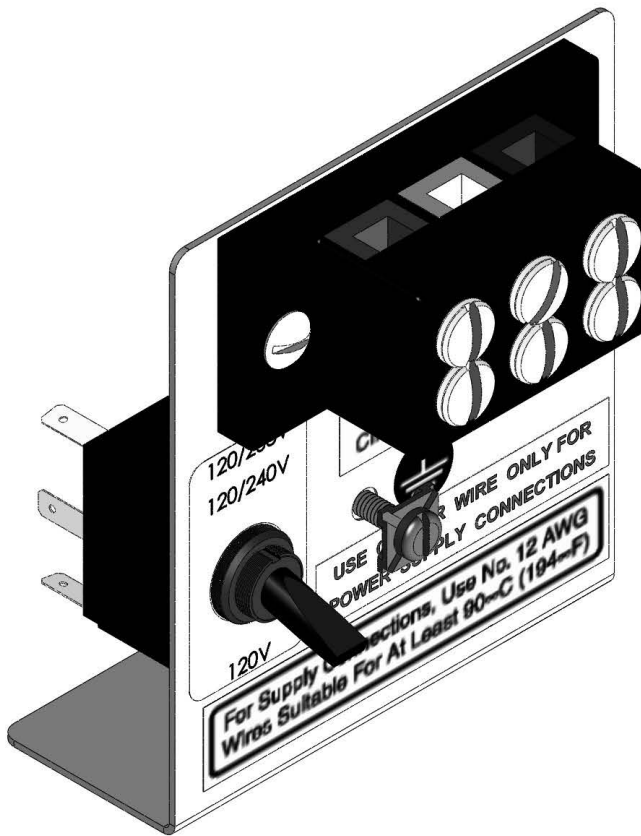

FIG. 21-1 VOLTAGE SELECTOR SWITCH

Location:

The voltage selector switch is located on the component mounting bracket on the base plate.

Test Procedure:

1. Disconnect the brewer from the power source.
2. Disconnect the wires from the selector switch. With the selector switch in the 120V position, check for continuity between the two right terminals of the switch.
3. With the selector switch in the 120/208-240V position, check for continuity between the two left terminals.

If continuity is not present as described, replace the switch.

Removal and Replacement:

1. Disconnect the brewer from the power source.
2. Disconnect the three wires from the selector switch.
3. Remove the switch mounting nut from the under side of component mounting bracket; remove switch from bracket.
4. Install new switch in component mounting bracket and secure with mounting nut.

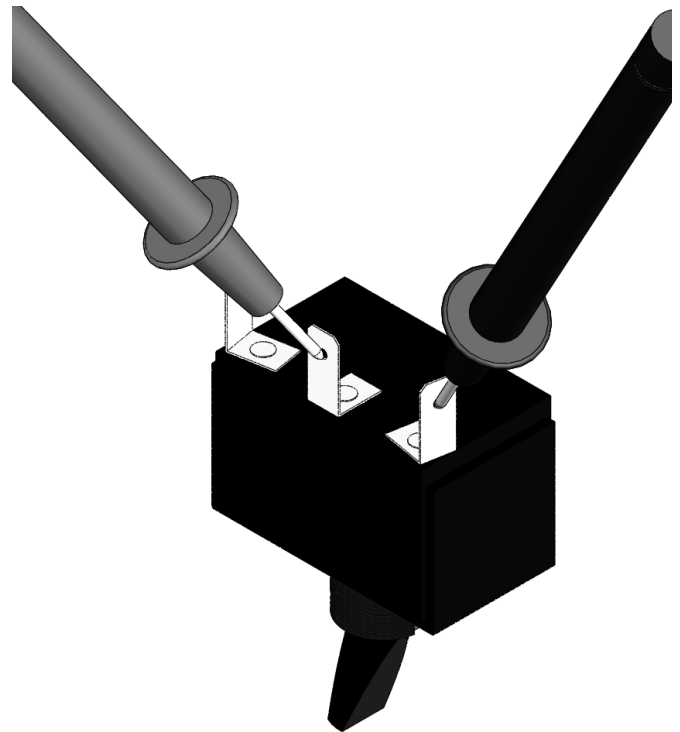

FIG. 21-2 VOLTAGE SELECTOR SWITCH TERMINALS

POWER SWITCH



FIG. 22-1 POWER SWITCH (ICB SHOWN)

Location:

The power switch is located on the lower right side of the trunk (ICB) or lower rear panel (ITCB).

Test Procedure:

1. Disconnect the brewer from the power source.
2. Disconnect the wires from the power switch. With the switch in the ON position, check for continuity between the upper and lower terminals on each side of the switch.

There should be continuity between the two left terminals and between the two right terminals when ON, no continuity when OFF.

If continuity is not present as described, replace the switch.

Removal and Replacement:

1. Disconnect the brewer from the power source.
2. Disconnect the wires from the power switch.
3. Remove the switch mounting screws from the left side of trunk.
4. Install new switch in trunk with the two 6-32 x 1/4" mounting screws.

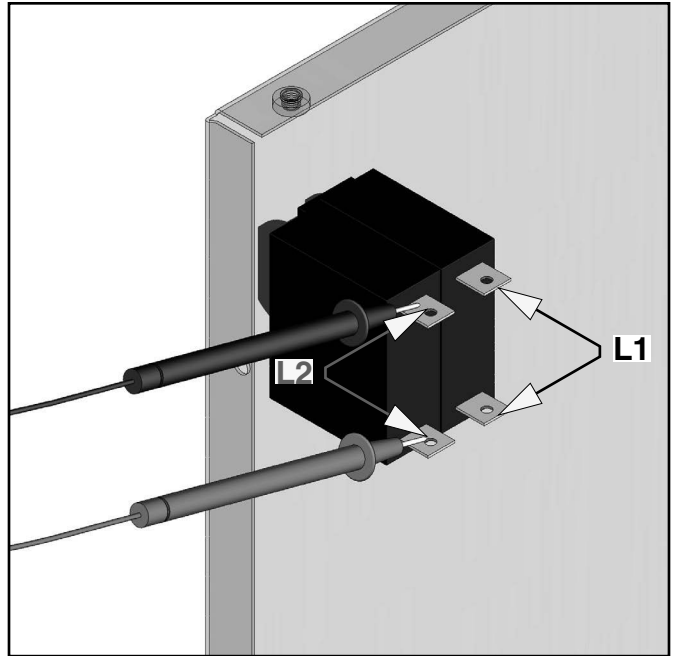

FIG. 22-2 ROCKER SWITCH

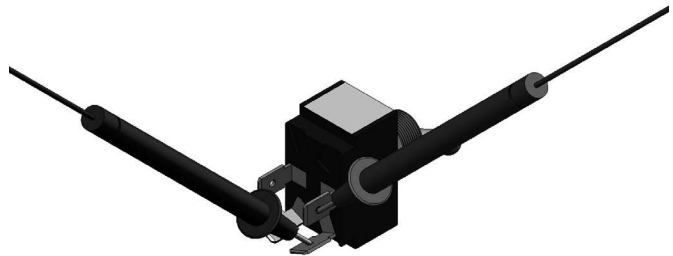
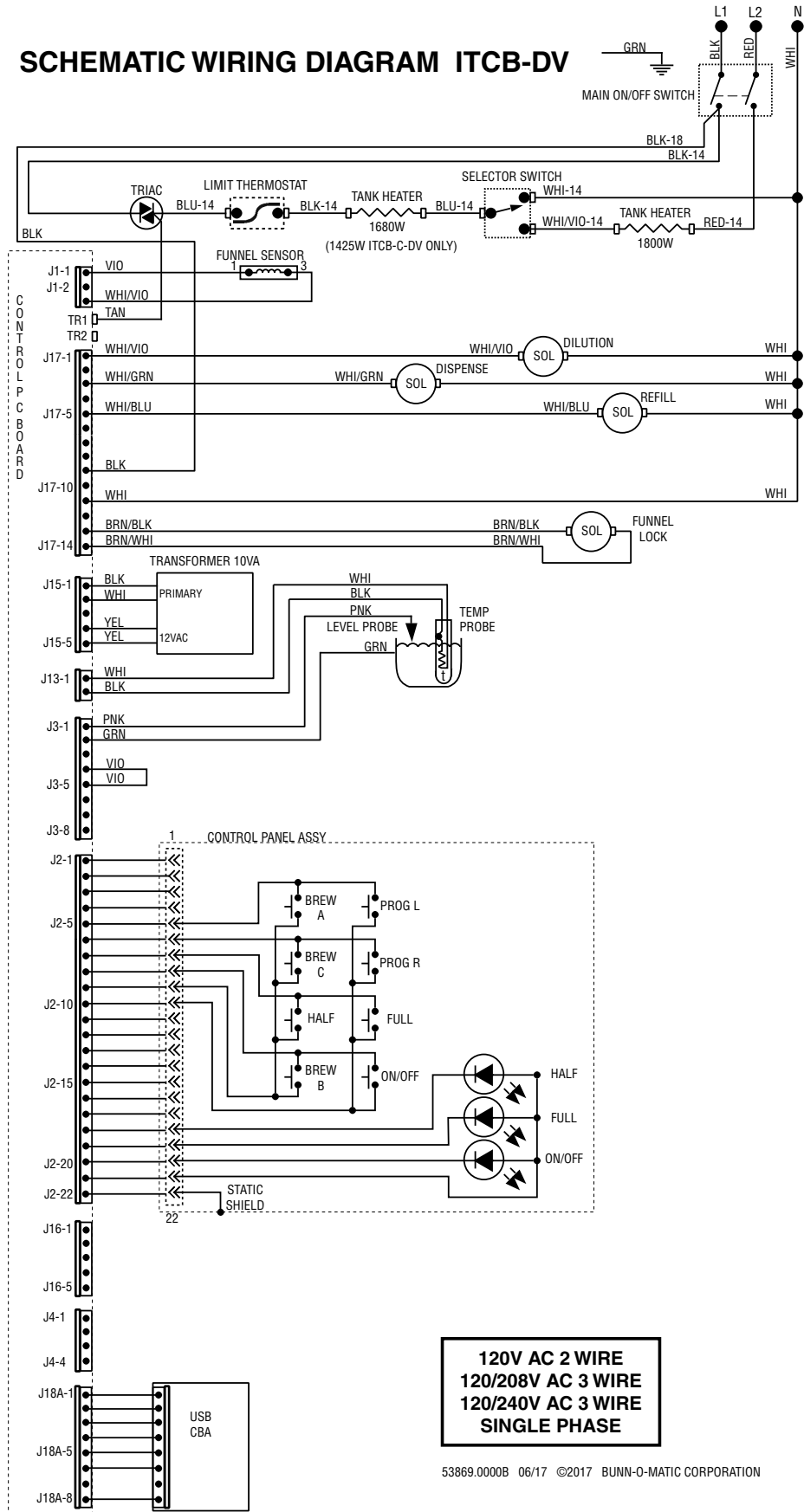
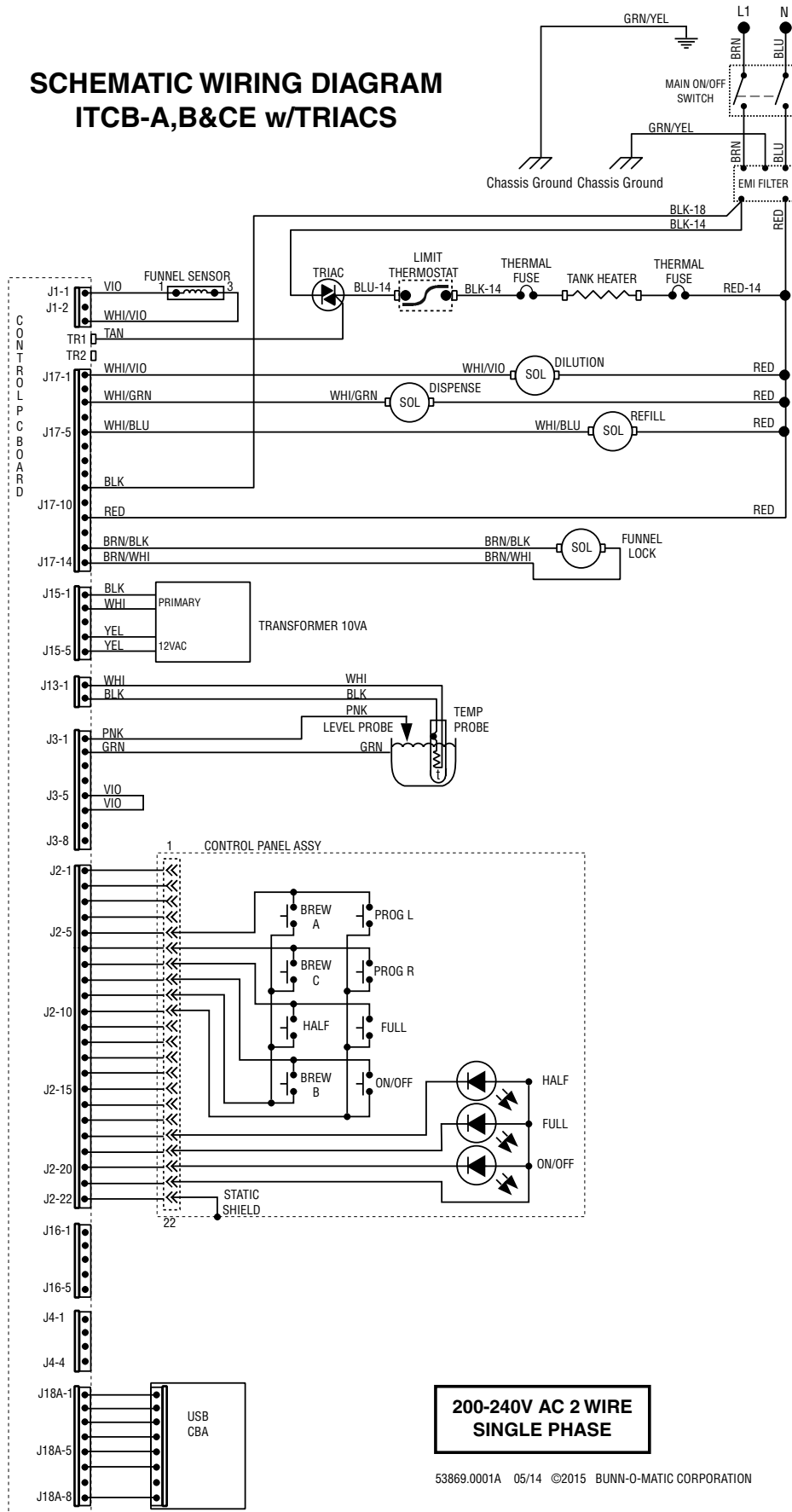

FIG. 22-3 TOGGLE SWITCH

SCHEMATIC WIRING DIAGRAM ITCB-DV



SCHEMATIC WIRING DIAGRAM ITCB-A,B&CE w/TRIACS



**200-240V AC 2 WIRE
SINGLE PHASE**

53869.0001A 05/14 ©2015 BUNN-O-MATIC CORPORATION

SCHEMATIC WIRING DIAGRAM ICB-DV

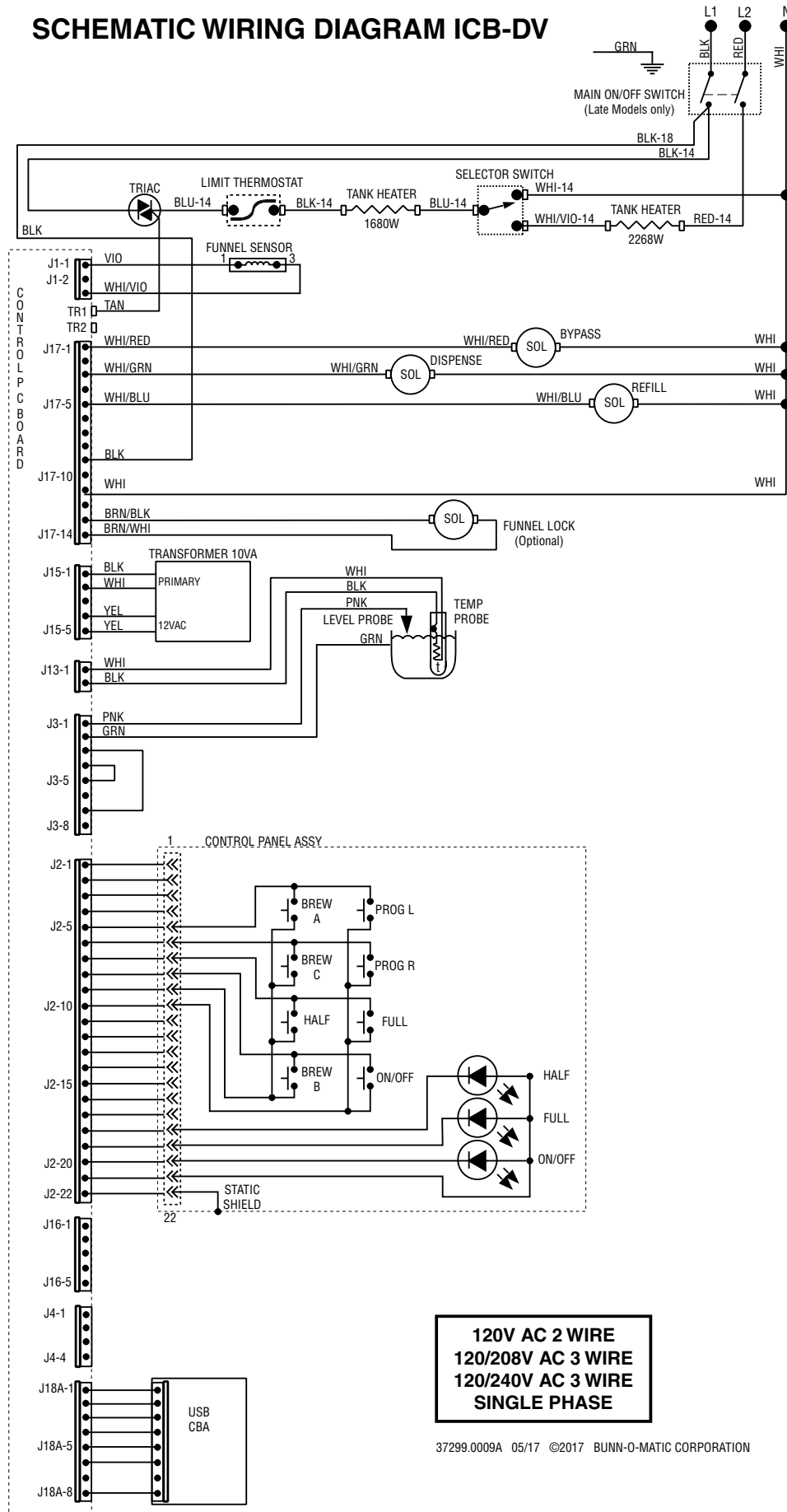

**120V AC 2 WIRE
120/208V AC 3 WIRE
120/240V AC 3 WIRE
SINGLE PHASE**

37299.0009A 05/17 ©2017 BUNN-O-MATIC CORPORATION

SCHEMATIC WIRING DIAGRAM ICB TWIN

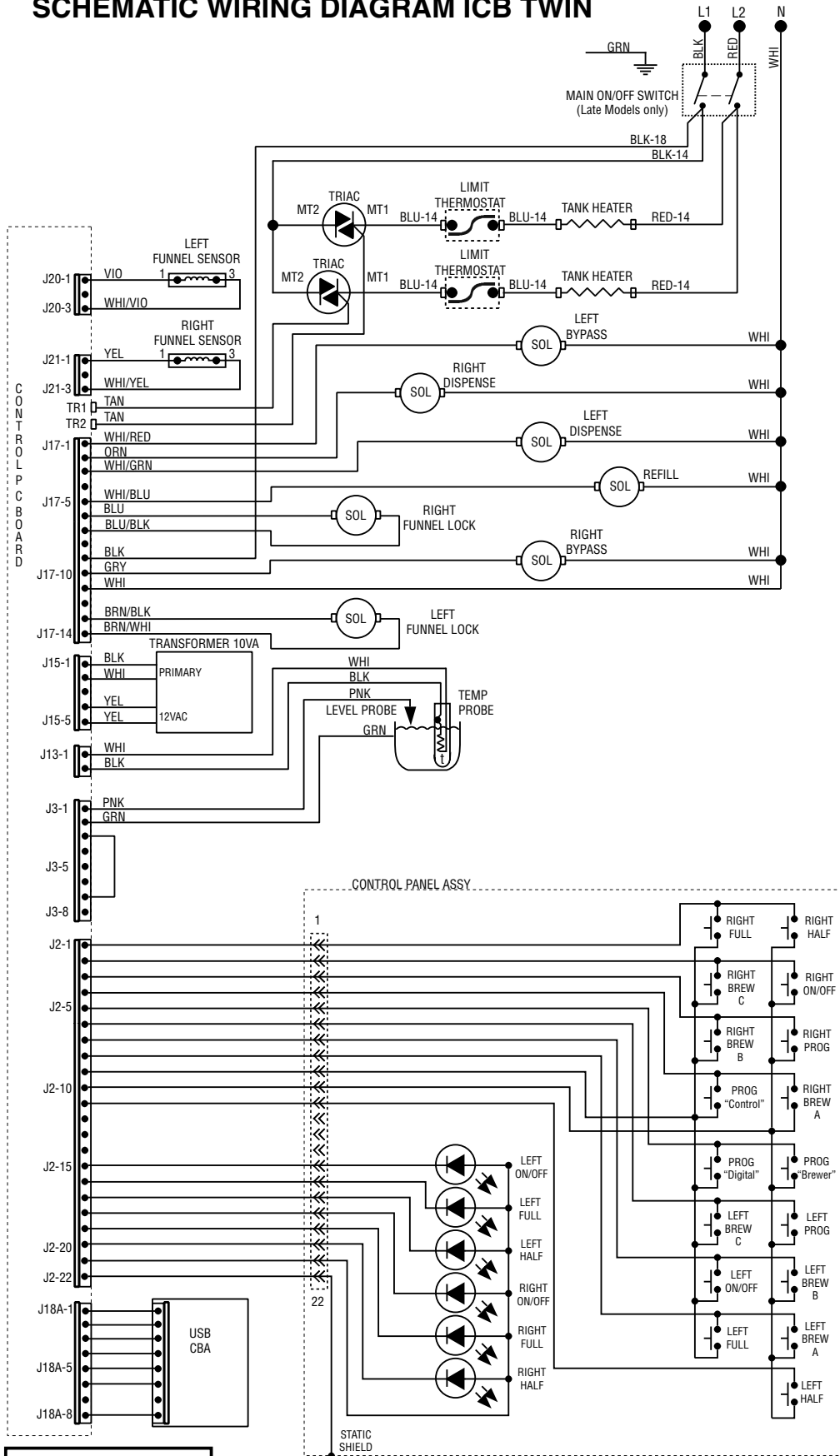

**120/208 OR 120/240
VOLTS AC
3 WIRE + GND
SINGLE PHASE**

SCHEMATIC WIRING DIAGRAM ICBA, ICBB & CE w/TRIACS

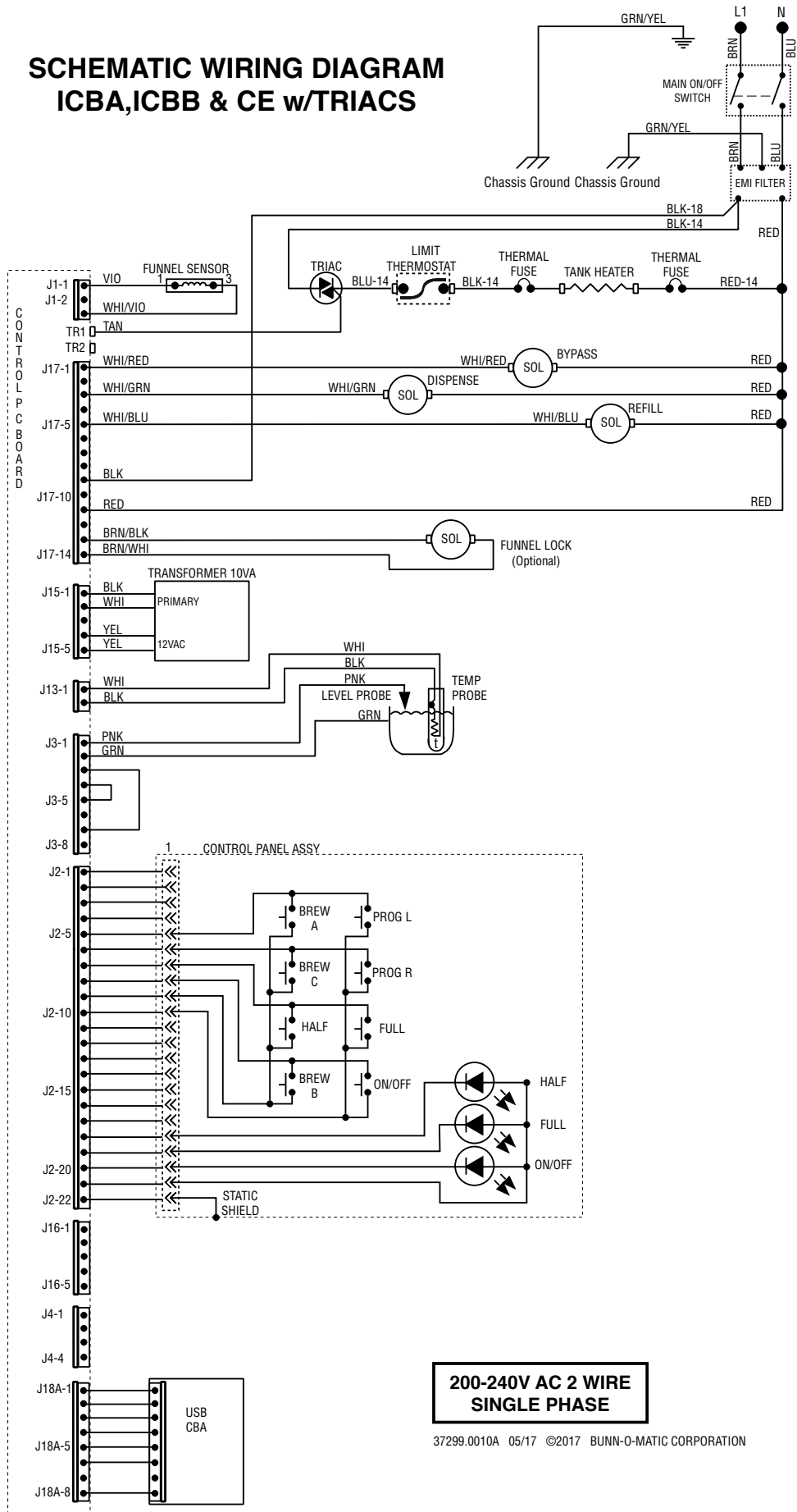

SCHEMATIC WIRING DIAGRAM ITCB HV TWIN

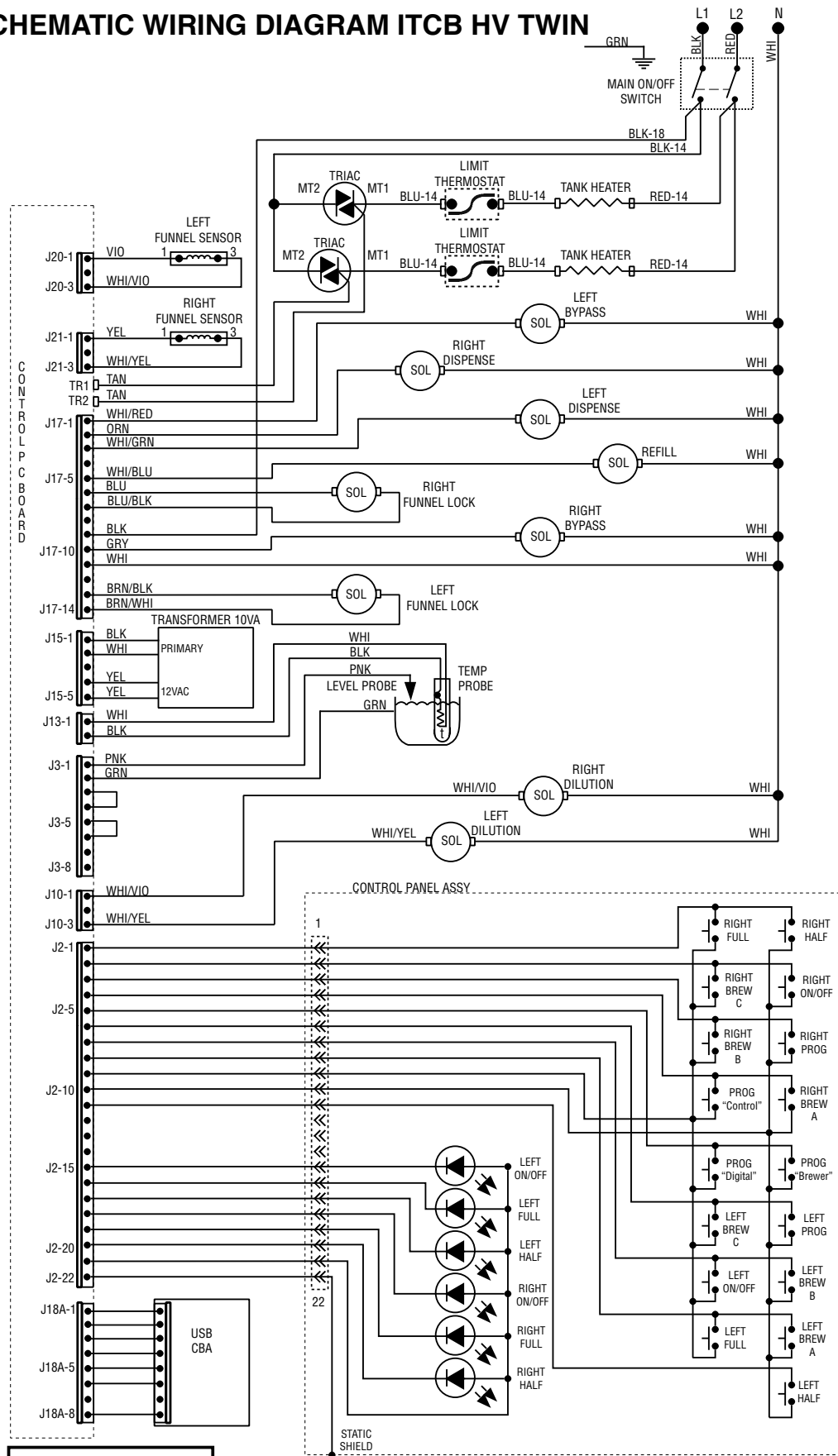

**120/208 OR 120/240
VOLTS AC
3 WIRE + GND
SINGLE PHASE**

SCHEMATIC WIRING DIAGRAM ITB

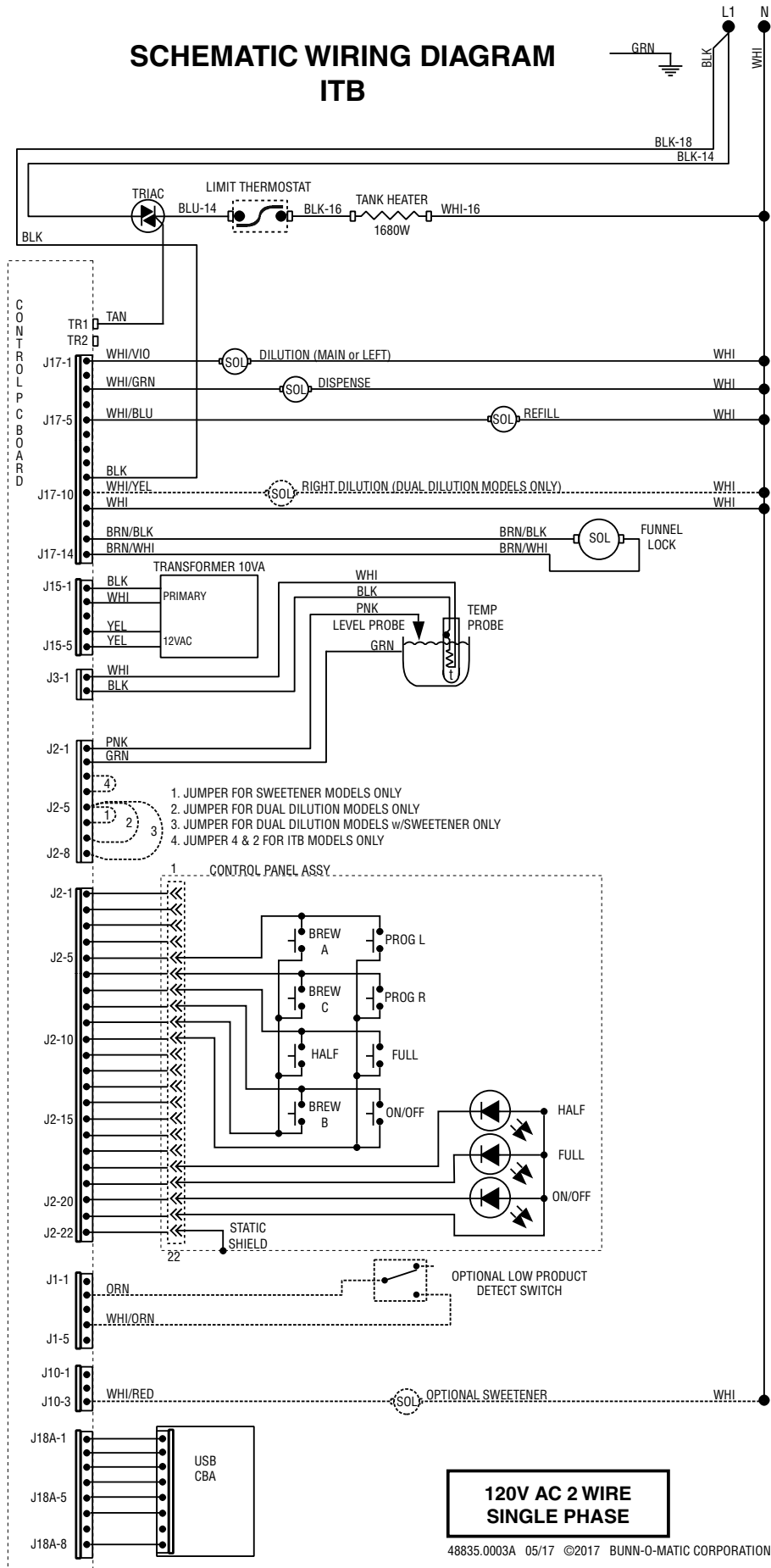

SCHEMATIC WIRING DIAGRAM ITCB-DV HV

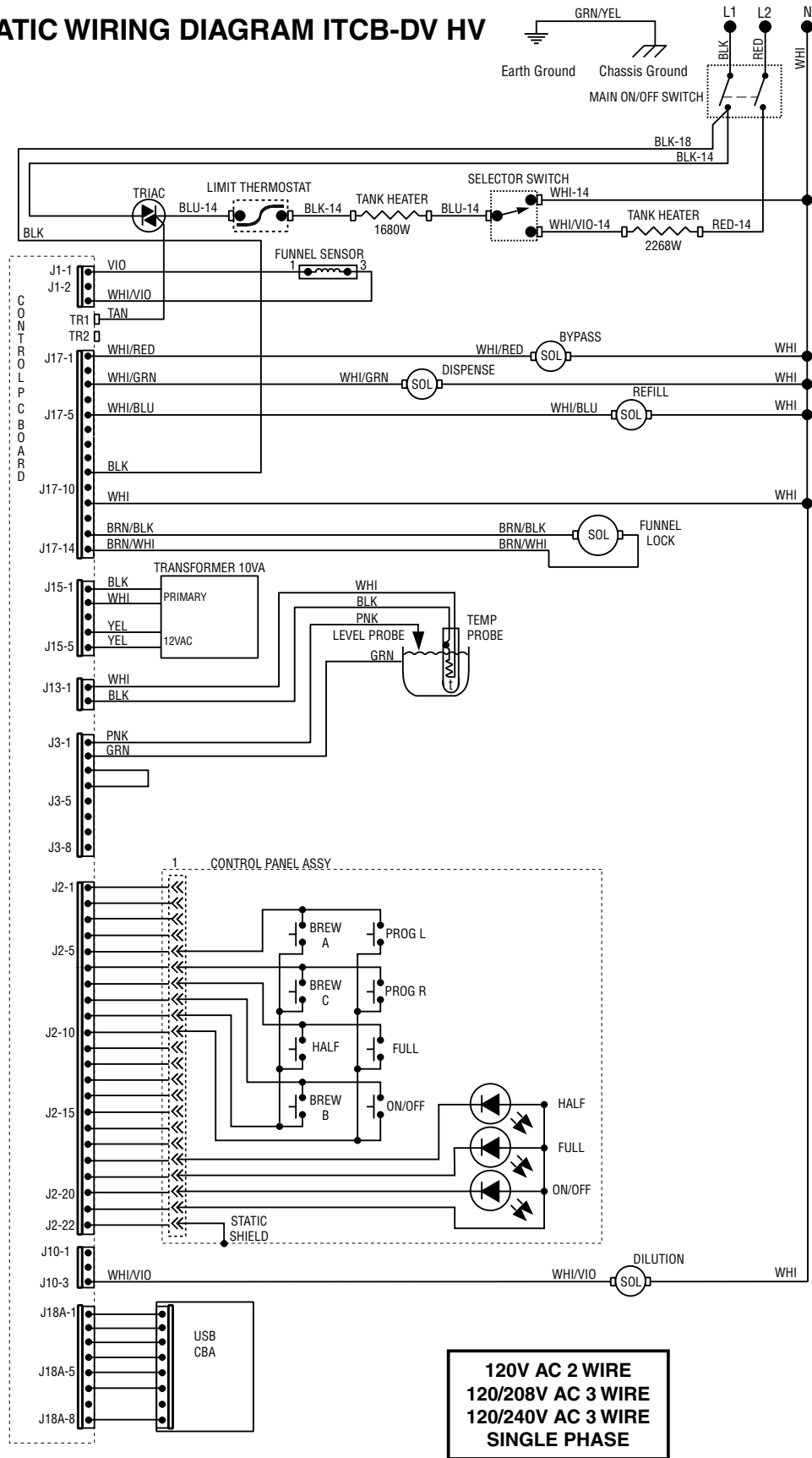

**120V AC 2 WIRE
120/208V AC 3 WIRE
120/240V AC 3 WIRE
SINGLE PHASE**

43828.0004A 06/17 ©2017 BUNN-O-MATIC CORPORATION

SCHEMATIC WIRING DIAGRAM ITBA-DUAL DILUTION/SWEETENER

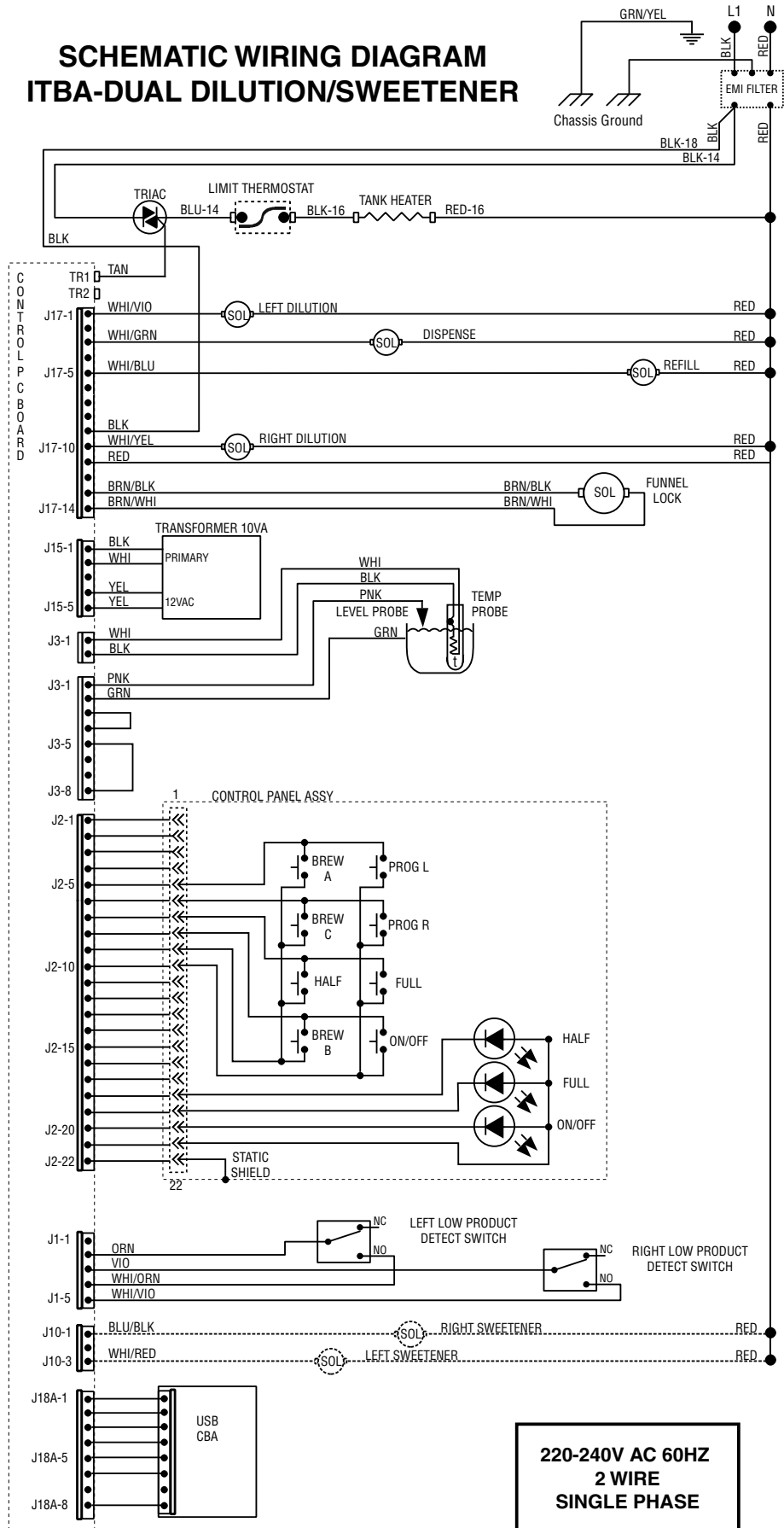

48835.0004A 06/17 ©2017 BUNN-O-MATIC CORPORATION