

BUNN®

LCC-2 LP *BUNN CHILLED*

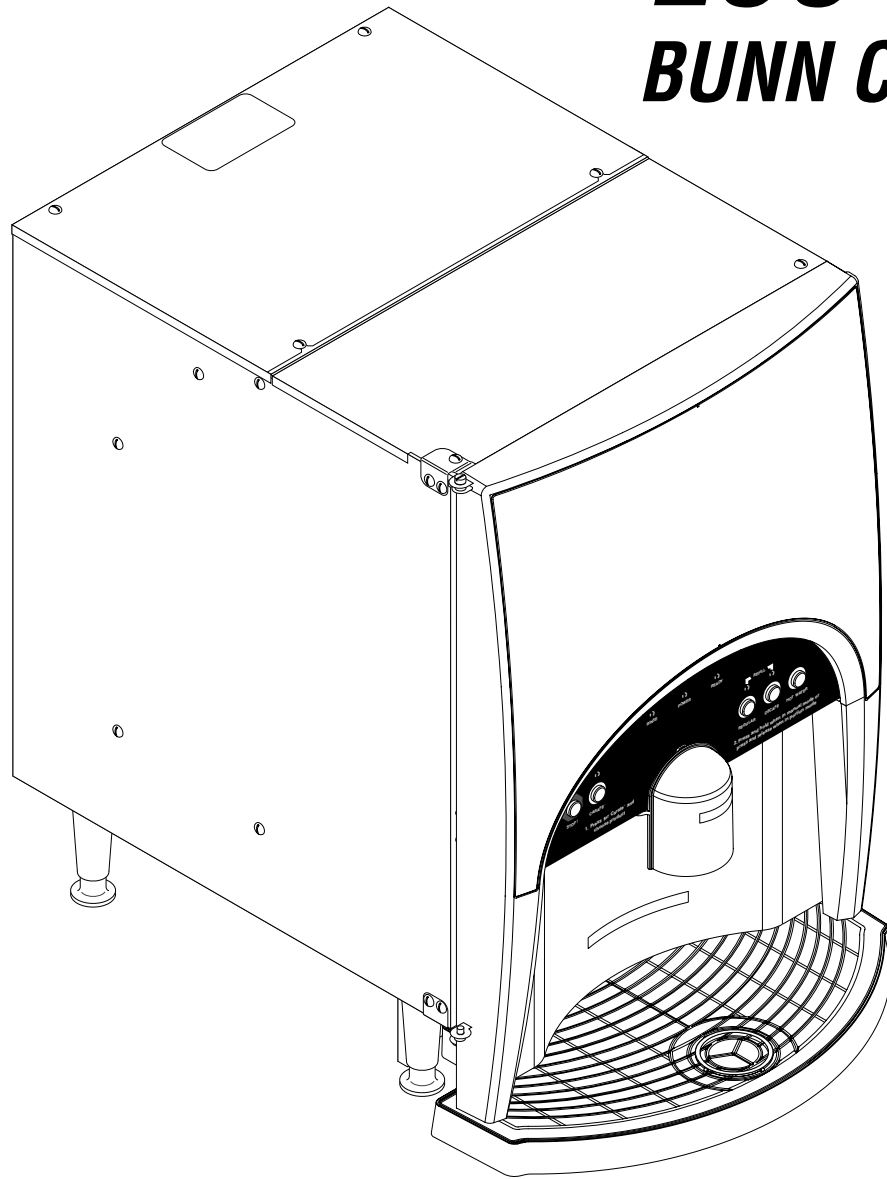

ILLUSTRATED PARTS CATALOG

Designs, materials, weights, specifications, and dimensions for equipment or replacement parts are subject to change without notice.

BUNN-O-MATIC CORPORATION

POST OFFICE BOX 3227

SPRINGFIELD, ILLINOIS 62708-3227

PHONE: (217) 529-6601 FAX: (217) 529-6644



BUNN-O-MATIC COMMERCIAL PRODUCT WARRANTY

Bunn-O-Matic Corp. ("BUNN") warrants equipment manufactured by it as follows:

- 1) Airpots, thermal carafes, decanters, GPR servers, iced tea/coffee dispensers, MCR/MCP/MCA single cup brewers, thermal servers and ThermoFresh® servers (mechanical and digital) 1 year parts and 1 year labor.
- 2) All other equipment - 2 years parts and 1 year labor plus added warranties as specified below:
 - a) Electronic circuit and/or control boards - parts and labor for 3 years.
 - b) Compressors on refrigeration equipment - 5 years parts and 1 year labor.
 - c) Grinding burrs on coffee grinding equipment to grind coffee to meet original factory screen sieve analysis - parts and labor for 4 years or 40,000 pounds of coffee, whichever comes first.

These warranty periods run from the date of installation BUNN warrants that the equipment manufactured by it will be commercially free of defects in material and workmanship existing at the time of manufacture and appearing within the applicable warranty period. This warranty does not apply to any equipment, component or part that was not manufactured by BUNN or that, in BUNN's judgment, has been affected by misuse, neglect, alteration, improper installation or operation, improper maintenance or repair, non periodic cleaning and descaling, equipment failures related to poor water quality, damage or casualty. In addition, the warranty does not apply to replacement of items subject to normal use including but not limited to user replaceable parts such as seals and gaskets. This warranty is conditioned on the Buyer 1) giving BUNN prompt notice of any claim to be made under this warranty by telephone at (217) 529-6601 or by writing to Post Office Box 3227, Springfield, Illinois 62708-3227; 2) if requested by BUNN, shipping the defective equipment prepaid to an authorized BUNN service location; and 3) receiving prior authorization from BUNN that the defective equipment is under warranty.

THE FOREGOING WARRANTY IS EXCLUSIVE AND IS IN LIEU OF ANY OTHER WARRANTY, WRITTEN OR ORAL, EXPRESS OR IMPLIED, INCLUDING, BUT NOT LIMITED TO, ANY IMPLIED WARRANTY OF EITHER MERCHANTABILITY OR FITNESS FOR A PARTICULAR PURPOSE. The agents, dealers or employees of BUNN are not authorized to make modifications to this warranty or to make additional warranties that are binding on BUNN. Accordingly, statements by such individuals, whether oral or written, do not constitute warranties and should not be relied upon.

If BUNN determines in its sole discretion that the equipment does not conform to the warranty, BUNN, at its exclusive option while the equipment is under warranty, shall either 1) provide at no charge replacement parts and/or labor (during the applicable parts and labor warranty periods specified above) to repair the defective components, provided that this repair is done by a BUNN Authorized Service Representative; or 2) shall replace the equipment or refund the purchase price for the equipment.

THE BUYER'S REMEDY AGAINST BUNN FOR THE BREACH OF ANY OBLIGATION ARISING OUT OF THE SALE OF THIS EQUIPMENT, WHETHER DERIVED FROM WARRANTY OR OTHERWISE, SHALL BE LIMITED, AT BUNN'S SOLE OPTION AS SPECIFIED HEREIN, TO REPAIR, REPLACEMENT OR REFUND.

In no event shall BUNN be liable for any other damage or loss, including, but not limited to, lost profits, lost sales, loss of use of equipment, claims of Buyer's customers, cost of capital, cost of down time, cost of substitute equipment, facilities or services, or any other special, incidental or consequential damages.

392, A Partner You Can Count On, Air Infusion, AutoPOD, AXIOM, BrewLOGIC, BrewMETER, Brew Better Not Bitter, BrewWISE, BrewWIZARD, BUNN Espresso, BUNN Family Gourmet, BUNN Gourmet, BUNN Pour-O-Matic, BUNN, BUNN with the stylized red line, BUNNlink, Bunn-O-Matic, Bunn-O-Matic, BUNNserve, BUNNSERVE with the stylized wrench design, Cool Froth, DBC, Dr. Brew stylized Dr. design, Dual, Easy Pour, EasyClear, EasyGard, FlavorGard, Gourmet Ice, Gourmet Juice, High Intensity, iMIX, Infusion Series, Intellisteam, My Café, Phase Brew, PowerLogic, Quality Beverage Equipment Worldwide, Respect Earth, Respect Earth with the stylized leaf and coffee cherry design, Safety-Fresh, savemycoffee.com, Scale-Pro, Silver Series, Single, Smart Funnel, Smart Hopper, SmartWAVE, Soft Heat, SplashGard, The Mark of Quality in Beverage Equipment Worldwide, ThermoFresh, Titan, trifacta, TRIFECTA (stylized logo), Velocity Brew, Air Brew, Beverage Bar Creator, Beverage Profit Calculator, Brew better, not bitter., Build-A-Drink, BUNNSource, Coffee At Its Best, Cyclonic Heating System, Daypart, Digital Brewer Control, Element, Milk Texturing Fusion, Nothing Brews Like a BUNN, Picture Prompted Cleaning, Pouring Profits, Signature Series, Sure Tamp, Tea At Its Best, The Horizontal Red Line, Ultra are either trademarks or registered trademarks of Bunn-O-Matic Corporation. The commercial trifacta® brewer housing configuration is a trademark of Bunn-O-Matic Corporation.

TABLE OF CONTENTS

Cabinet Assembly	10
Dispense Valve and Mixing Chamber	22
Door Assembly	8
Electrical Components	24
Fan, Air Duct & Filter.....	12
Housing, Panels & Drip Tray	4
Numerical Index.....	26
Pump Assembly.....	14
Tank Assembly.....	20
Water Inlet & Tank Drain (Early Models)	16
Water Inlet & Tank Drain (Late Models)	18

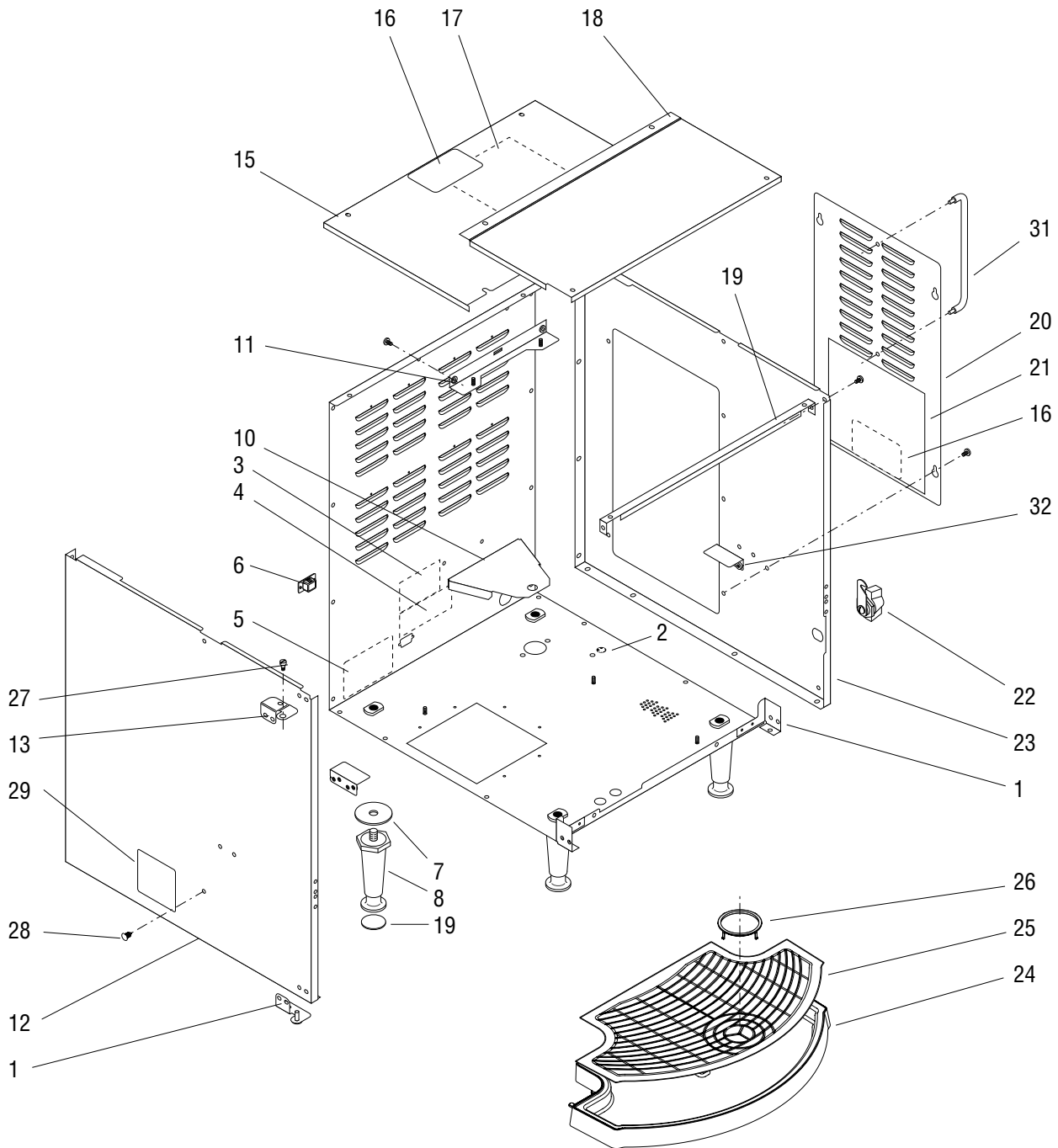

HOUSING, PANELS AND DRIP TRAY

ITEM	PART NO.	QTY.	DESCRIPTION
1	37590.1000	1	Housing (Models w/Horton Inlet Valve)(Includes items 2 - 4)
	41315.1000	1	Housing (Models w/Eltek Inlet Valve)(Includes items 2 - 4)
2	00824.0002	1	Decal, Ground Screw
3	00986.0002	1	Decal, Warning - Electrical
4	00656.0001	1	Decal, Comply to Plumbing Code
5	-----	1	Machine Data Plate (Not serviced)
6	36398.0000	1	Plug, BunnLink Access (Not used in all applications)
7	01526.0001	4	Washer
8	26528.0000	4	Leg
9	03996.0000	4	Pad, Non-skid
10	36941.0000	1	Bracket, Lower Tank Mount
	01315.0005	2	Screw, Truss Head BLK #8-32 x .38"
11	34118.0001	1	Bracket, Upper Tank Mount
	01315.0005	2	Screw, Truss Head BLK #8-32 x .38"
12	37708.0003	1	Panel, Left Side
	01315.0005	7	Screw, Truss Head BLK #8-32 x .38"
13	37578.0001	1	Hinge Bracket, Upper
	01315.0005	3	Screw, Truss Head BLK #8-32 x .38"
14	37716.0001	1	Hinge Bracket, Lower
	01315.0005	3	Screw, Truss Head BLK #8-32 x .38"
15	36945.1000	1	Top Cover w/Decals, Rear (Includes items 16 & 17)
	01315.0005	2	Screw, Truss Head BLK #8-32 x .38"
16	37881.0000	2	Decal, No Serviceable Parts
17	25151.0008	1	Shield, Insulator
18	36938.0001	1	Top Cover, Front
	01315.0005	4	Screw, Truss Head BLK #8-32 x .38"
19	36944.0000	1	Bracket
	01315.0005	1	Screw, Truss Head BLK #8-32 x .38"
20	42442.1000	1	Panel, Access
	01315.0005	4	Screw, Truss Head BLK #8-32 x .38"
21	37921.0003	1	Electrical Schematic 120V
22	34472.0000	1	Lock, Door (Includes Keys)
	28095.0000	1	Key Set
23	37589.0003	1	Panel, Right Side
	01315.0005	10	Screw, Truss Head BLK #8-32 x .38"
24	37846.1000	1	Drip Tray
25	38185.1000	1	Cover Assy, Drip Tray (Includes item 26)

(Continued)

* Indicates the part number listed is for reference only. See DESCRIPTION for possible service replacement.

(Continued)

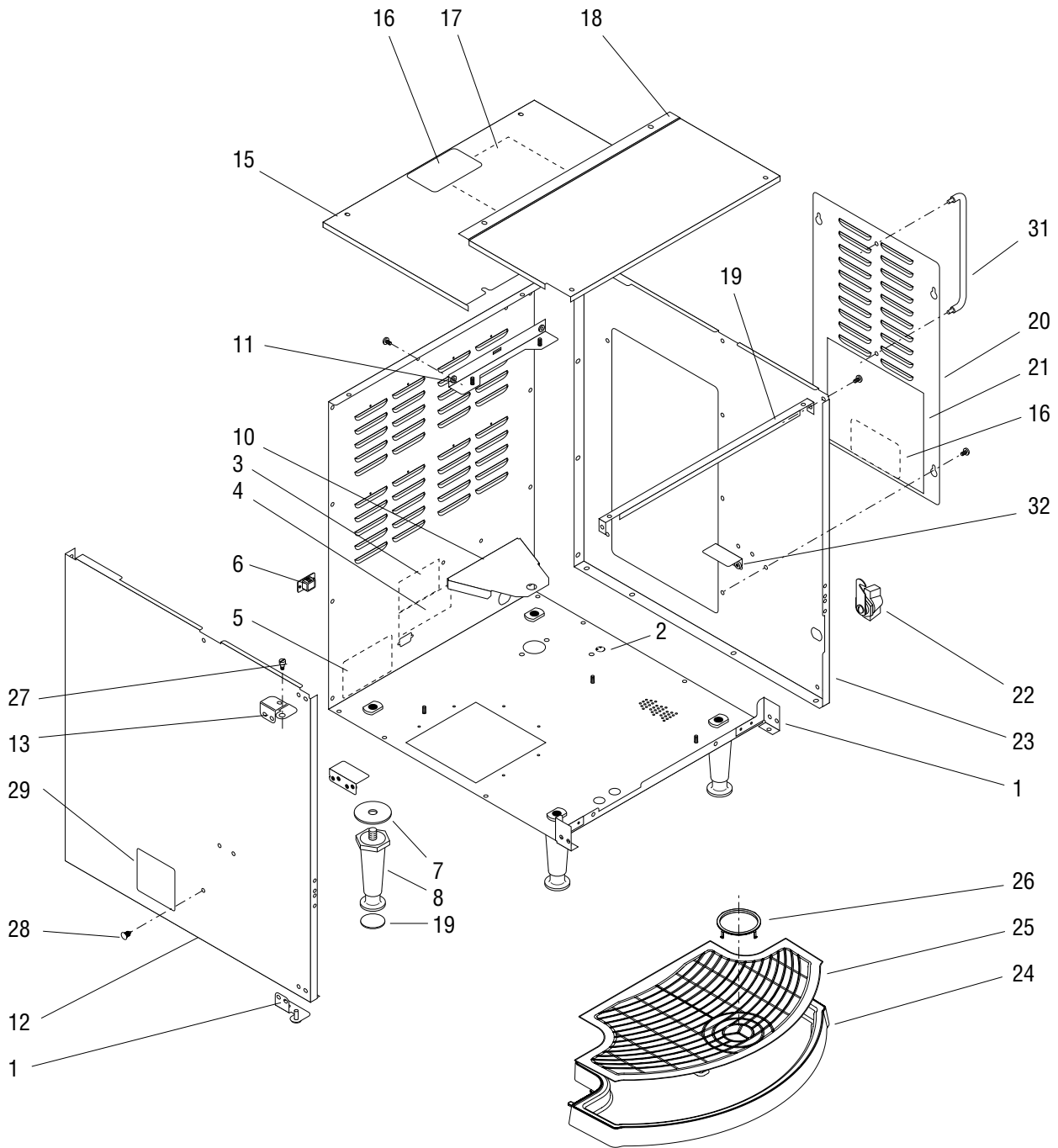

HOUSING, PANELS AND DRIP TRAY

ITEM	PART NO.	QTY.	DESCRIPTION
26	38047.1000	1	Cup Locator Ring
27	29504.0004	1	Screw, Shoulder #8-32 x .38" Lkg
28	36149.0000	1	Fastener
29	40054.0002*	1	Decal, Air Filter (Order item 30)
30	40054.0000	1	Decal Set
31	12249.1002	1	Guide Rail Kit (Includes nuts)(Optional Equipment)
32	42440.0000	2	Bracket, Cabinet Support
	01315.0005	4	Screw, Truss Head BLK #8-32 x .38"

* Indicates the part number listed is for reference only. See DESCRIPTION for possible service replacement.

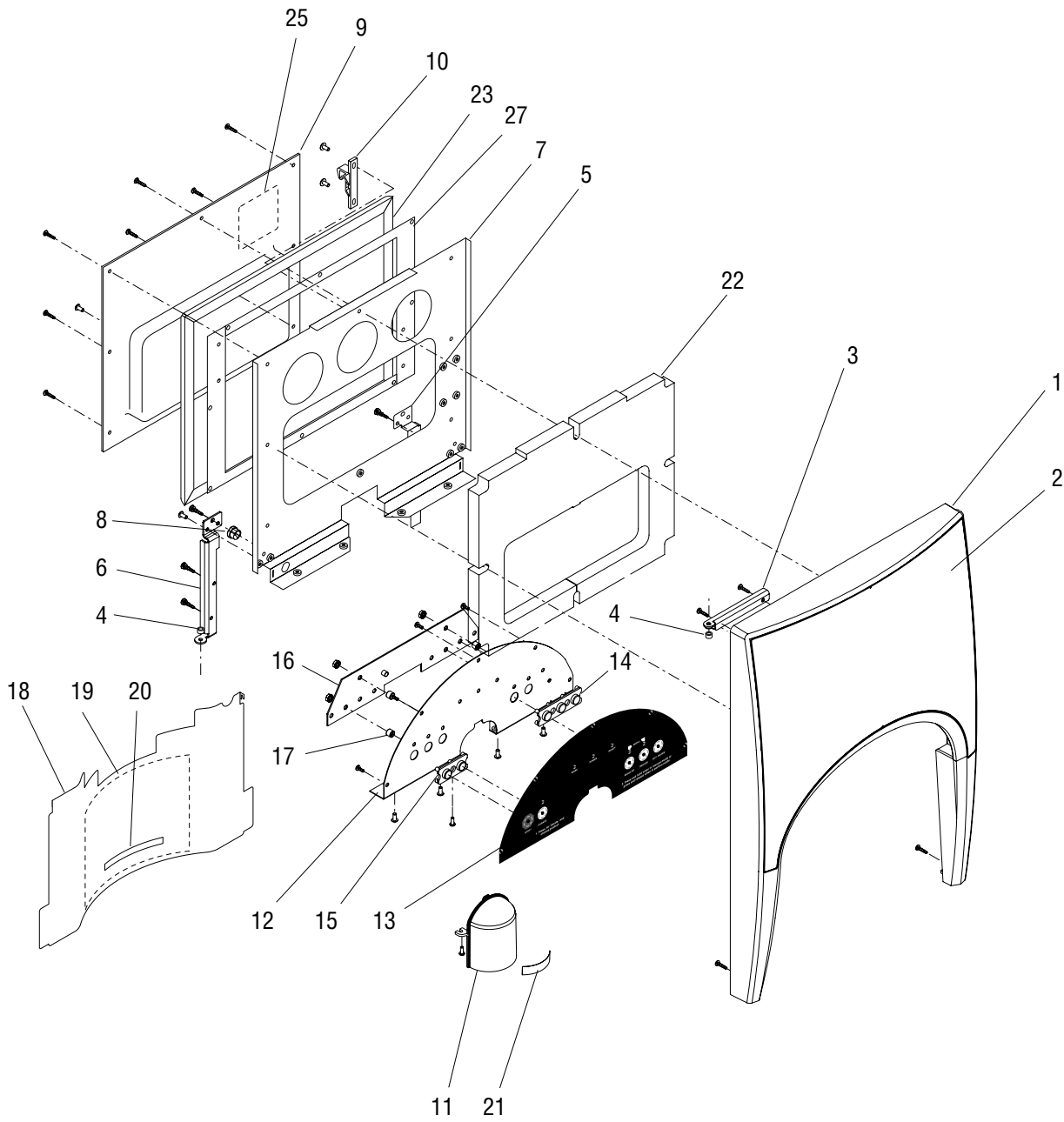

DOOR ASSEMBLY

ITEM	PART NO.	QTY.	DESCRIPTION
-	37826.0005*	1	Door Assembly (Includes items 1-17 & 21-24)
1	37438.1002	1	Door
2	37833.0001	1	Decal, Door Graphic
3	38072.0000	1	Hinge, Top Door
	44224.0000	2	Screw, Pan Head #6-20 x .38"
4	37825.0000	2	Spacer
5	37690.0000	1	Bracket, Door Lock Right
	38838.0000	4	Screw, Pan Head, Phillips #6 x .625"
	01382.0000	1	Screw, Truss Head #8 x .38"
6	37446.0000	1	Hinge, Bottom Door
	38838.0000	4	Screw, Pan Head, Phillips #6 x .625"
	01382.0000	1	Screw, Truss Head #8 x .38"
7	37442.0001	1	Bracket, Door Support
8	04822.0000	1	Bushing, Strain Relief
9	38795.1002	1	Liner, Inner Door (Includes item 25)
	38838.0000	7	Screw, Pan Head, Phillips #6 x .625"
	01382.0000	1	Screw, Truss Head #8 x .38"
10	34667.0000	1	Keeper, Door Latch
	01315.0000	2	Screw, Truss Head #8-32 x .38"
11	38794.1000	1	Cover W/Decal, Dispense Nozzle (Includes item 21)
	21717.0000	2	Screw, Pan Head, Std #6-32 x .375"
12	37440.1000	1	Panel w/Decals (Includes item 13)
	44224.0000	5	Screw, Pan Head #6-20 x .38"
	01382.0000	4	Screw, Truss Head #8 x .38"
13	37585.0000	1	Decal, Control Panel
14	34387.0001	1	Cover, Push Button 3 Switch
15	34387.0000	1	Cover, Push Button 2 Switch
16	39008.1000	1	Circuit Board
17	37828.0000	5	Spacer
	00970.0000	5	Nut, Keps #8-32
18	37444.1001	1	Panel, Splash w/Decals (Includes items 19 & 21)
	38838.0000	2	Screw, Pan Head, Phillips #6 x .625"
19	38792.0000	1	Decal, Cleaning
20	11646.0002	1	Decal, Warning - Hot Liquid (English/French)
21	37280.0000	1	Decal, Warning - Hot Liquid
22	37441.0000	1	Insulation
23	36937.0000	1	Seal
24	37916.0000	1	Wiring Harness, Door Interconnect (Not illustrated)
25	40054.0001*	1	Decal, Air Filter (Order item 26)
26	40054.0000	1	Decal Set
27	41033.0000*	2	Spacer, Door Liner

* Indicates the part number listed is for reference only. See DESCRIPTION for possible service replacement.

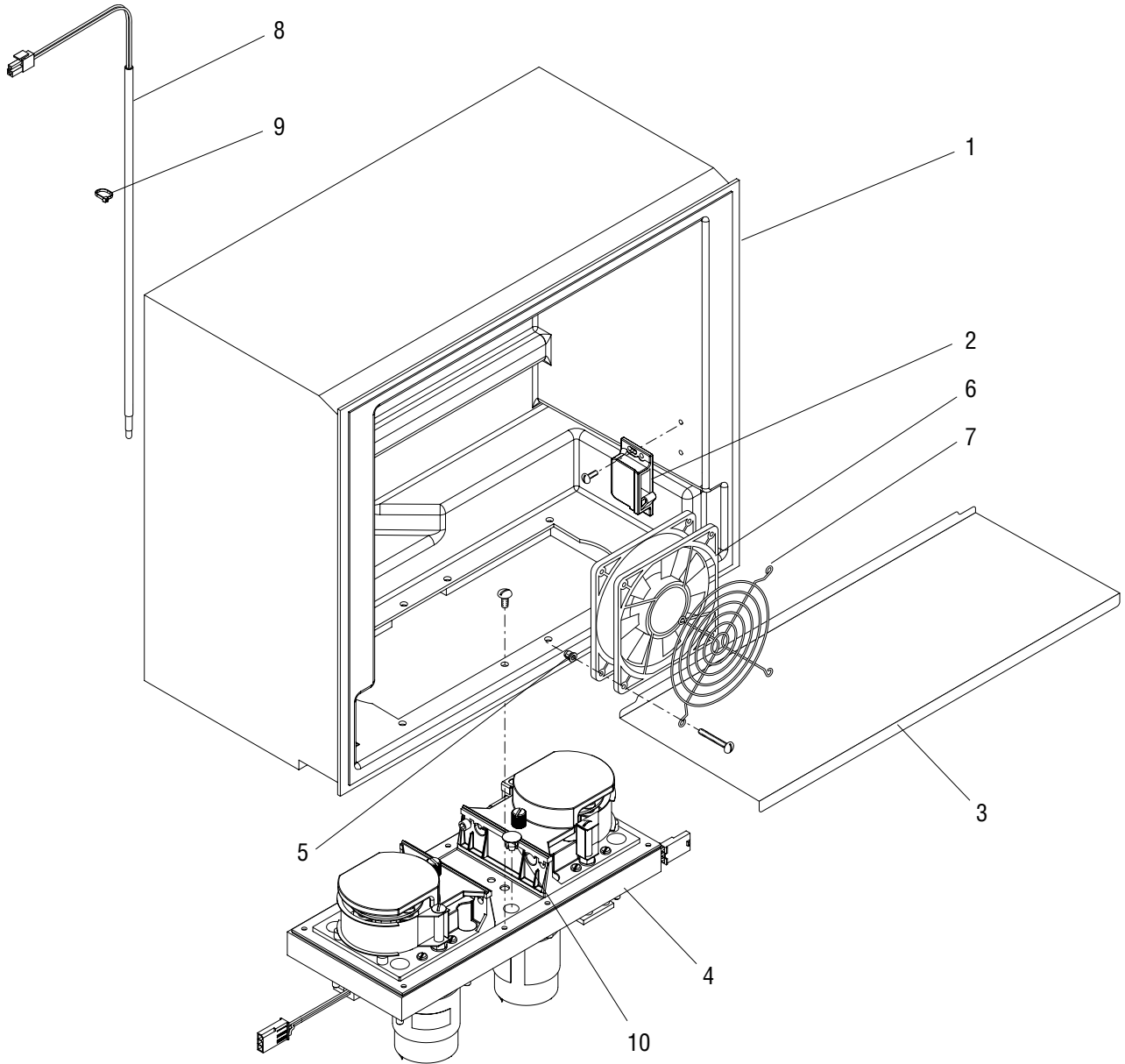

CABINET ASSEMBLY

ITEM	PART NO.	QTY.	DESCRIPTION
1	38797.0002*	1	Cabinet, Foamed
	44224.0000	2	Screw, Pan Head, Phillips #6-20 x .38"
2	34666.0001	1	Catch, Door Latch
	48817.0000	2	Screw, Pan Head #4-40 x .50"
3	38807.1001	1	Platform, Product (Includes edging)
4	-----	1	Pump Assy (See PUMP ASSEMBLY)
	01315.0000	8	Screw, Truss Head #8 x .38"
5	38810.0000	4	Insert
6	33358.0000	1	Fan
7	34010.0000	1	Guard, Fan
	02370.0001	4	Screw, Pan Head #6-32 x 1.25"
8	34803.1000	1	Sensor, Temperature
9	00617.0000	1	Tie, Cable
10	40204.0000	1	Plug

* Indicates the part number listed is for reference only. See DESCRIPTION for possible service replacement.

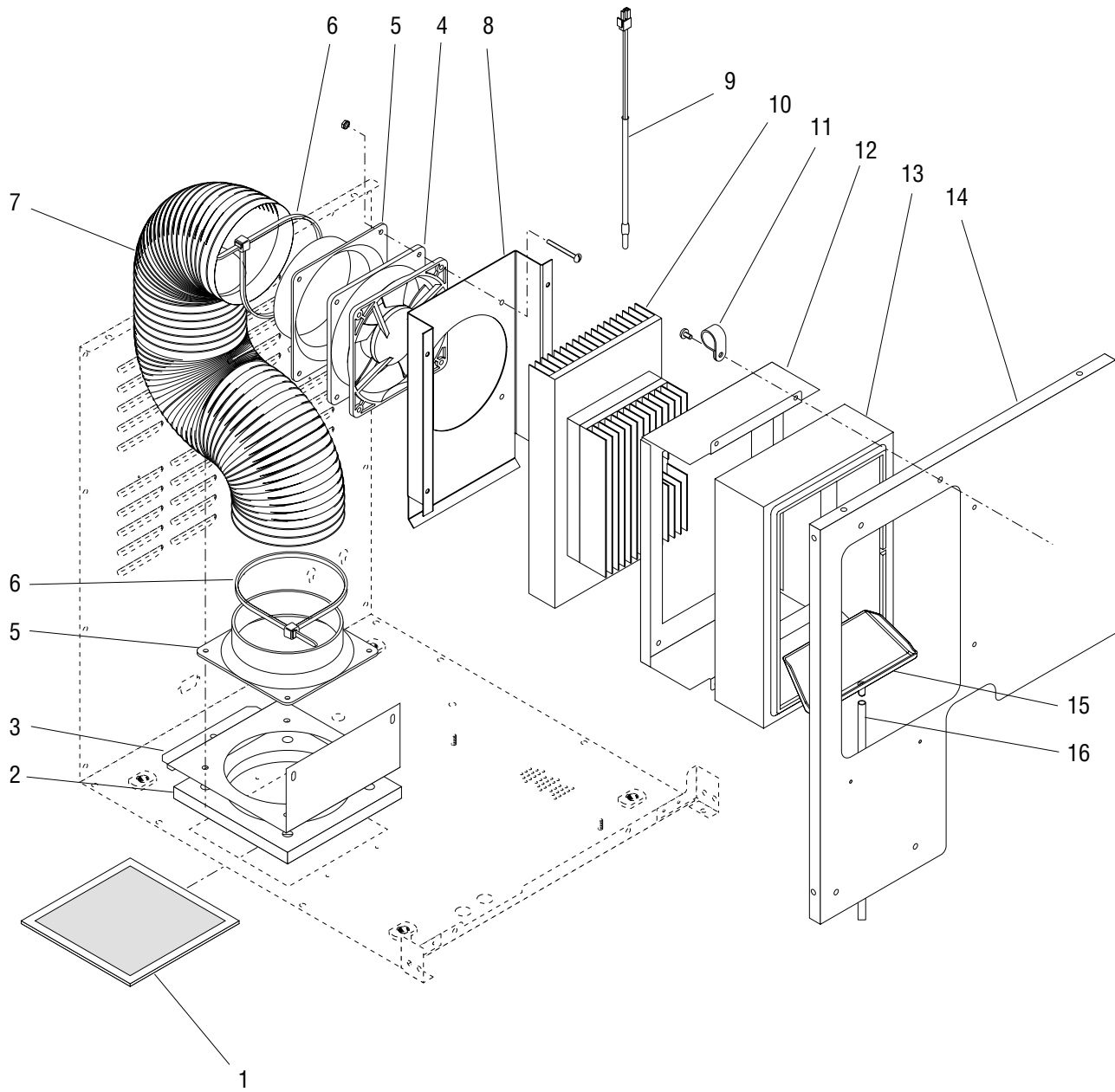

FAN, AIR DUCT & FILTER

ITEM	PART NO.	QTY.	DESCRIPTION
1	35833.0000	1	Filter Screen
2	32280.0000	1	Foam, Air Duct Fan
3	38806.0000	1	Bracket
	01315.0000	4	Screw, Truss Head #8-32 x .38"
	01311.0000	2	Screw, Truss Head #8-32 x .25"
	00970.0000	1	Nut, Keps #8-32
4	33297.0002	1	Fan Assy
	01384.0002	4	Screw, Truss Head #8-32 x 2.0"
	00970.0000	4	Nut, Keps #8-32
5	38808.0000	2	Adapter, 4" Duct
6	32734.0000	2	Tie, Cable
7	38811.0000	1	Air Duct
8	38804.0000	1	Bracket (Early models w/ base mounted fan)
	38803.0000	1	Bracket (Late models)
	01382.0000	4	Screw, Truss Head #6-32 x .38"
9	28891.1000	1	Probe, temperature
10	34265.1002	1	Thermoelectric Assy
	01326.0000	4	Screw, Truss Head #10-32 x .25"
11	00603.0000	1	Clamp
	01315.0000	1	Screw, Truss Head #8-32 x .38"
12	38802.0000	1	Bracket
	01315.0000	2	Screw, Truss Head #8-32 x .38"
13	38809.0001	1	Foam, Chiller
14	38799.0000	1	Panel, Center
	01315.0005	5	Screw, Truss Head BLK #8-32 x .38"
15	38822.0000	1	Condensation Tray
16	34726.0004*	1	Tube, Norprene .125" ID x 12.0"

* Indicates the part number listed is for reference only. See DESCRIPTION for possible service replacement.

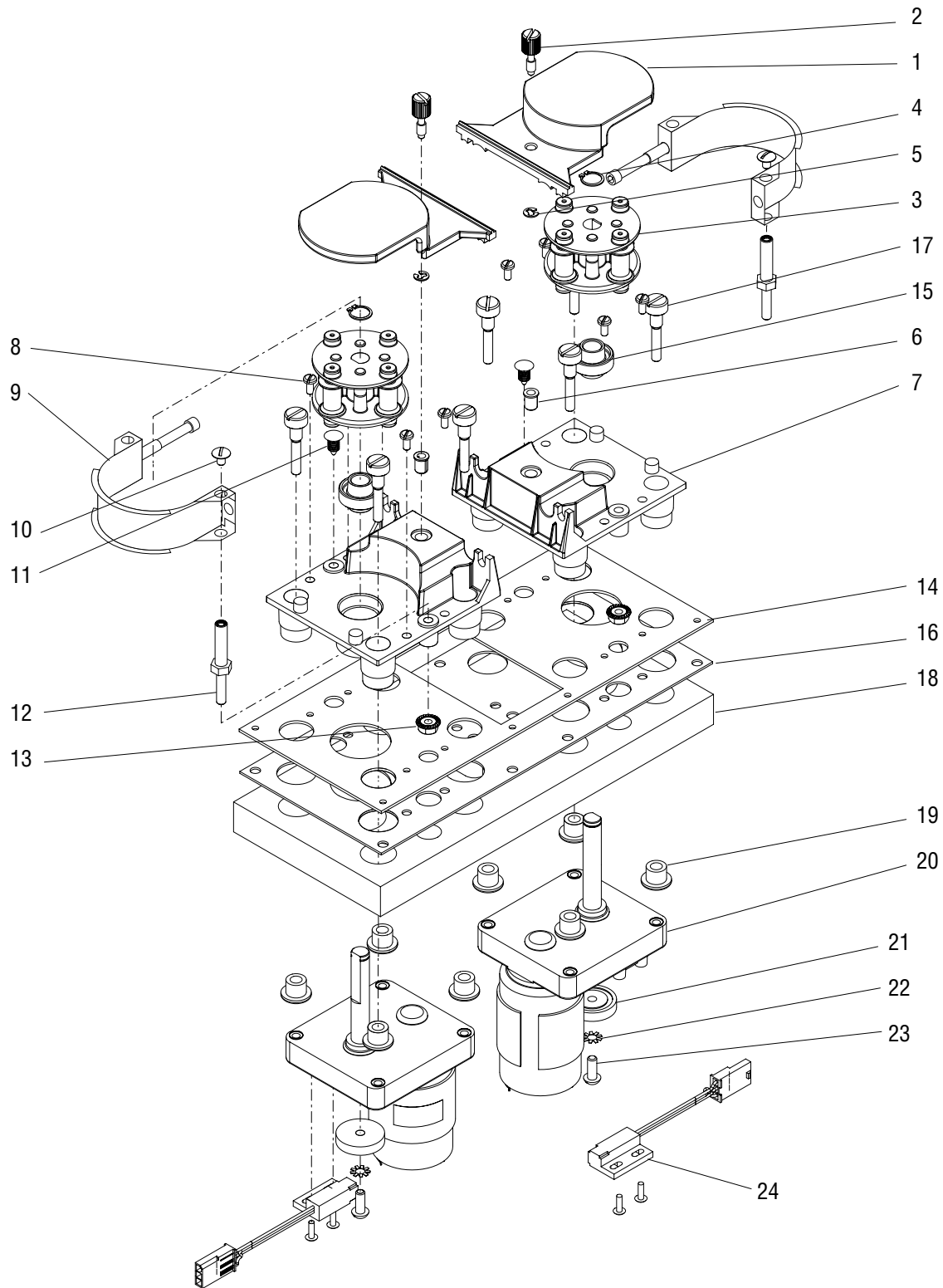

PUMP ASSEMBLY

ITEM	PART NO.	QTY.	DESCRIPTION
-	37829.1000	1	Pump Assy (Includes items 1 thru 24)
1	34167.0000	2	Cover, Pump Block
2	34997.0000	2	Thumb Screw
3	32706.1000	2	Rotor
4	32652.0000	2	Retaining Ring
5	34998.0000	2	Retaining Ring
6	32928.0000	2	Insert, Threaded
7	34166.1002	2	Block Assy, Pump (Includes items 6 & 15)
8	02328.0003	8	Screw, Pan Head #6-32 x .312"
9	40030.1000	2	Compression Band Assy
10	01311.0001	2	Screw, Truss Head #8-32 x .25" Locking
11	36149.0000	2	Fastener
12	32609.0000	2	Standoff
13	34765.0000	2	Nut, Flanged #10-32
14	40050.0001	1	Gasket
15	33825.0000	2	Bearing
16	36928.0000	1	Bracket, Pump Mounting
17	32927.0000	8	Screw, Shoulder #10-32 UNC
18	37580.0000	1	Insulation, Pump
19	32957.0000	8	Bushing
20	34536.0001	2	Motor
21	32654.0000	2	Magnet Hub
22	01512.0000	2	Lockwasher, External-tooth #10
23	01331.0004	2	Screw, Round Head, Locking #10-32
24	33608.1000	2	Sensor, RPM
	02336.0000	4	Screw, Truss Head #4-40 x .38"
25	00617.0000	1	Cable Tie (Not Illustrated)

* Indicates the part number listed is for reference only. See DESCRIPTION for possible service replacement.

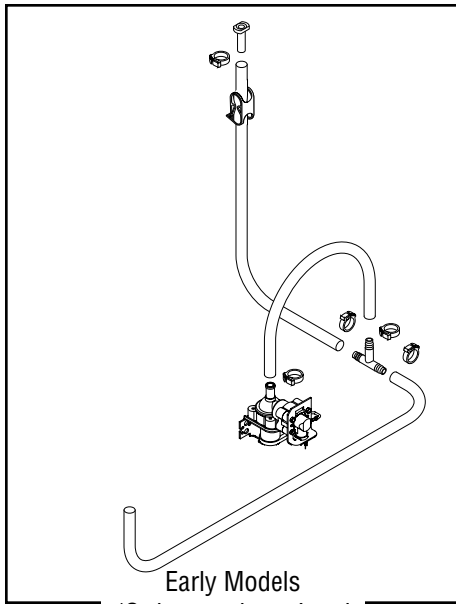

Early Models
(Order new item 4 and
re-configure as shown)

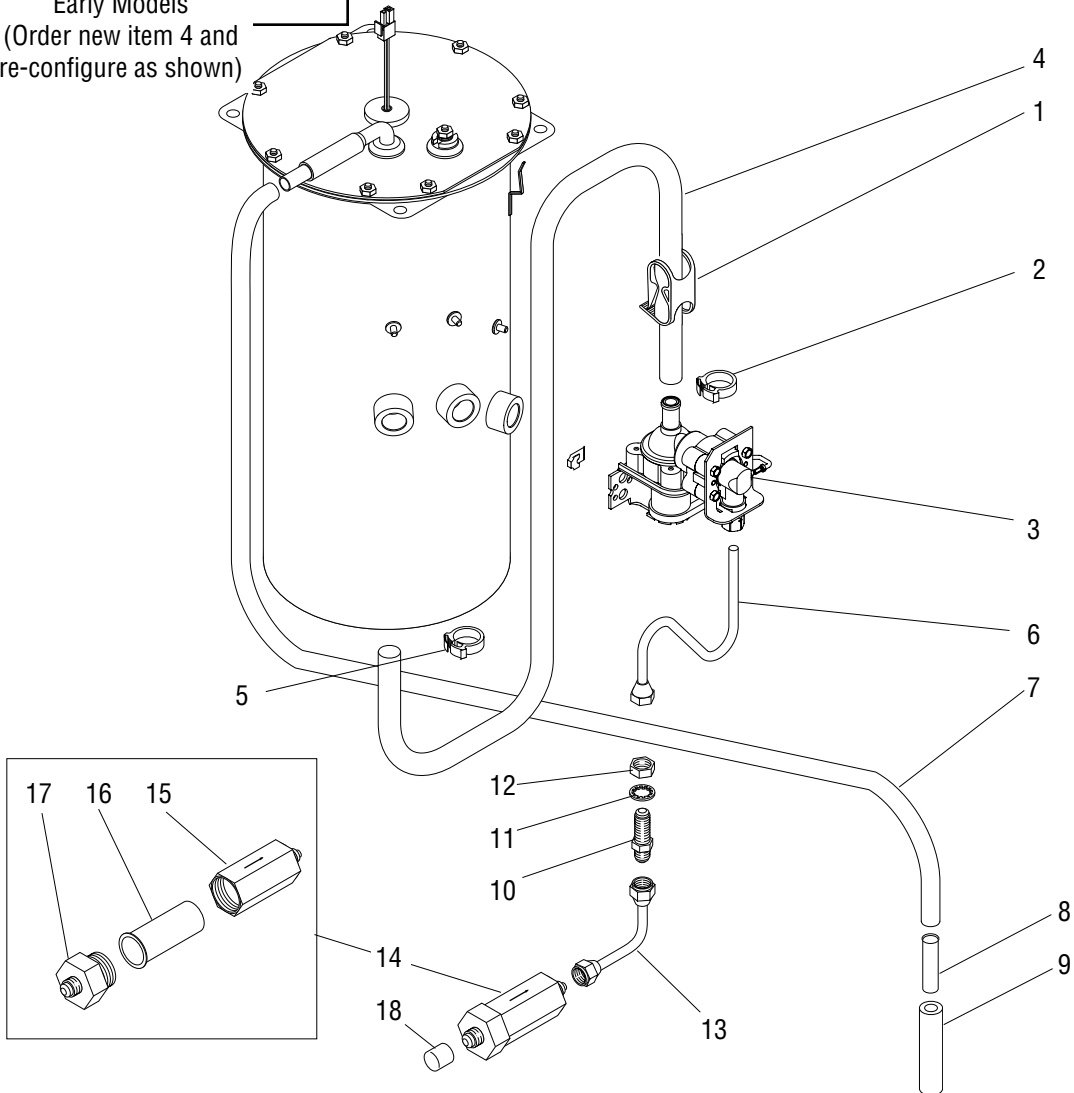

WATER INLET & TANK DRAIN (Early Models)

ITEM	PART NO.	QTY.	DESCRIPTION
1	11630.0001	1	Clamp, Shut off
2	12422.0001	1	Clamp .59/.66" ID
3	26135.0005	1	Valve (Horton), Water Inlet 120V
	01315.0005	2	Screw, Truss Head BLK #8-32 x .38"
	00938.0000	2	Fastener, U-type #8-32
4	28526.0000*	1	Tube, Silicone .313" ID x 11.5" (Order item 19)
5	12422.0006	1	Clamp .53/.59" ID
6	26661.0000	1	Tube, Water Inlet
7	28526.0009*	1	Tube, Silicone .313" ID x 24.0" (Order item 19)
8	21801.0002	1	Tube, SST .375" O.D. x 1.50"
9	28526.0029*	1	Tube, Silicone .313" I.D. x .50" (Order item 19)
10	00459.0000	1	Fitting, Bulkhead
11	01532.0000	1	Lockwasher, Internal tooth .438"
12	00463.0000	1	Nut, Hex .438"-20
13	21814.0016	1	Tube
14	23820.1000	1	Strainer Assy (Includes items 15 - 17)
15	23819.0000*	1	Body (Order item 14)
16	23721.0000	1	Screen
17	22249.0000	1	Cap, End
18	12919.0005	1	Cap (For shipping purposes only)
19	28526.1000	-	Tube, Silicone .313" ID x 12.0" (Use as required)
	28526.1001	-	Tube, Silicone .313" ID x 36.0" (Use as required)
	28526.1002	-	Tube, Silicone .313" ID x 60.0" (Use as required)
	28526.1003	-	Tube, Silicone .313" ID x 120.0" (Use as required)

* Indicates the part number listed is for reference only. See DESCRIPTION for possible service replacement.

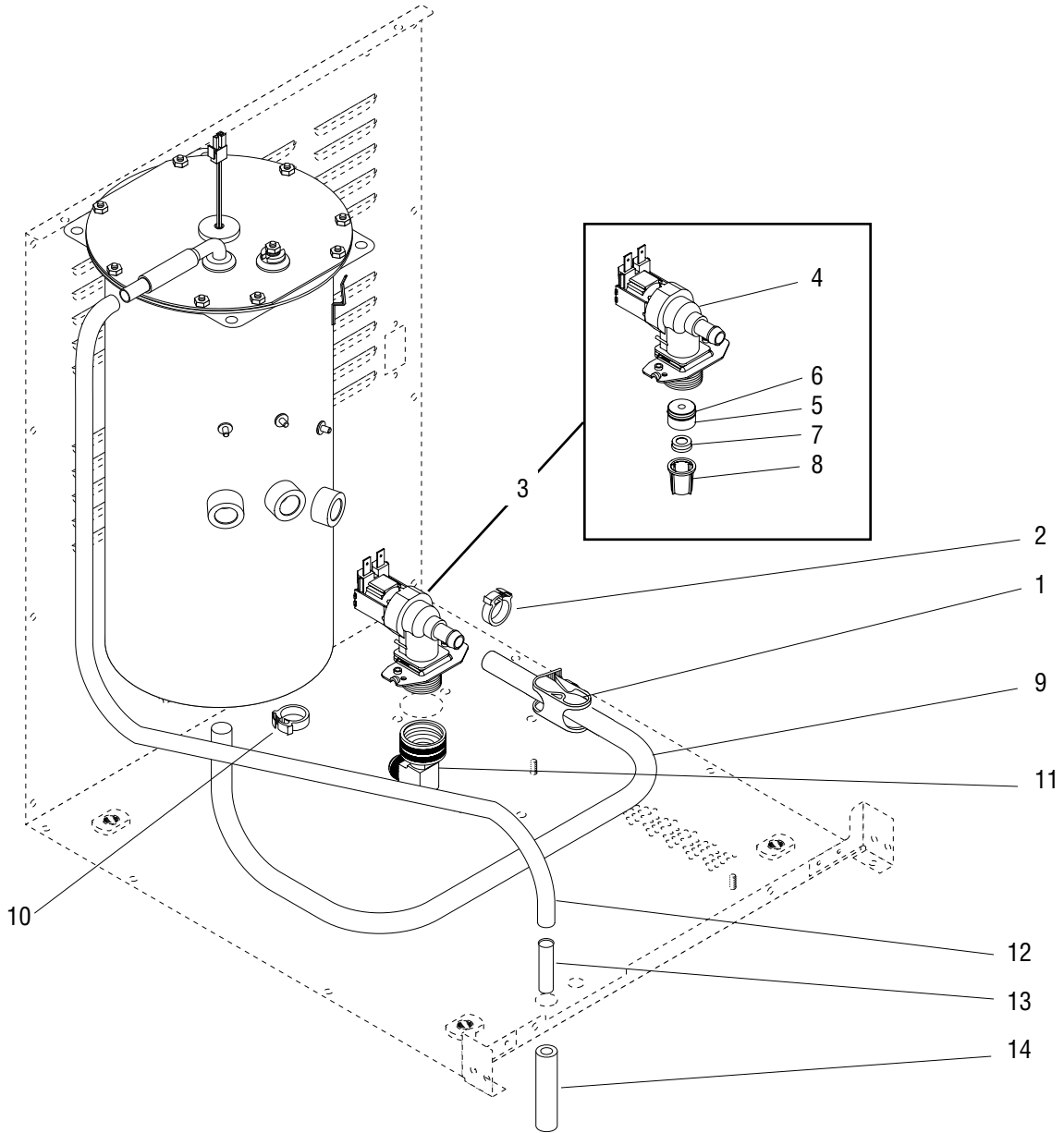

WATER INLET & TANK DRAIN (Late Models)

ITEM	PART NO.	QTY.	DESCRIPTION
1	11630.0001	1	Clamp, Shut off
2	12422.0001	1	Clamp .59/.66" ID
3	40506.0006	1	Valve (Eltek), Water Inlet 120V (Includes items 4 thru 8)
	32283.0000	2	Screw, Pan Head BLK M4 x .6mm
4	36233.0000	1	Valve 120V
	36233.0001	1	Valve 240V
5	40056.0004	1	Housing, Flow Control
6	33725.0000	1	O-ring
7	37857.1750	1	Flow Control
8	-----	1	Screen
9	20976.0056*	1	Tube, Silicone .38" ID x 28.0" (Order item 15)
10	12422.0006	1	Clamp .53/.59" ID
11	37297.0006	1	Fitting, Elbow .375" FI
12	28526.0009*	1	Tube, Silicone .313" ID x 24.0" (Order item 16)
13	21801.0002	1	Tube, SST .375" O.D. x 1.50"
14	28526.0029*	1	Tube, Silicone .313" I.D. x .50" (Order item 16)
15	20976.1000	-	Tube, Silicone .375" ID x 12.0" (Use as required)
	20976.1001	-	Tube, Silicone .375" ID x 36.0" (Use as required)
	20976.1002	-	Tube, Silicone .375" ID x 120.0" (Use as required)
16	28526.1000	-	Tube, Silicone .313" ID x 12.0" (Use as required)
	28526.1001	-	Tube, Silicone .313" ID x 36.0" (Use as required)
	28526.1002	-	Tube, Silicone .313" ID x 60.0" (Use as required)
	28526.1003	-	Tube, Silicone .313" ID x 120.0" (Use as required)

* Indicates the part number listed is for reference only. See DESCRIPTION for possible service replacement.

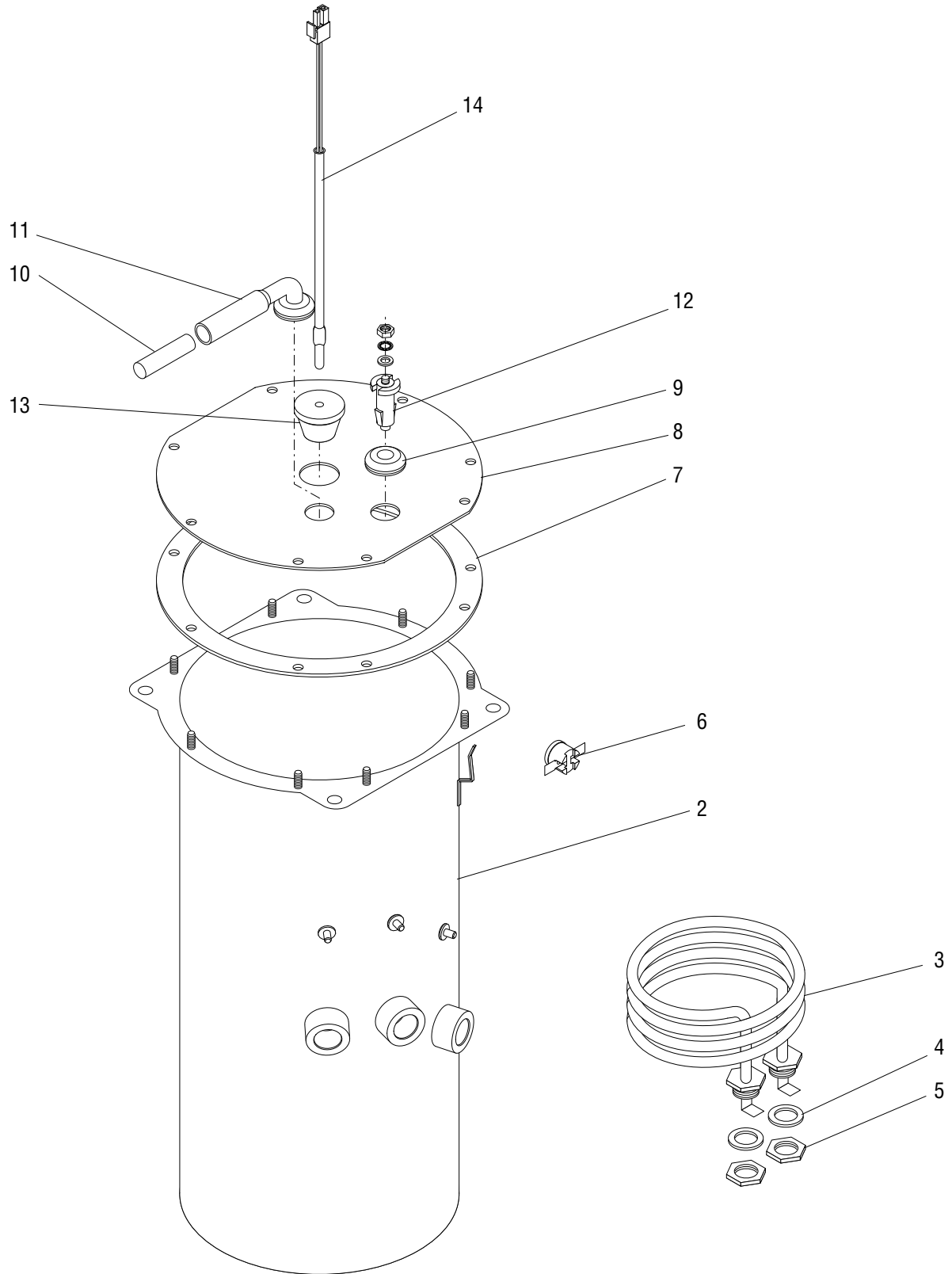

TANK ASSEMBLY

ITEM	PART NO.	QTY.	DESCRIPTION
-	37812.1000	1	Tank Assy 120V (Includes item 1 - 14)
	00970.0000	3	Nut, Keps #8-32
1	36934.0000	1	Insulation, Tank (Not illustrated)
2	36931.0000	1	Tank
3	02755.1000	1	Tank Heater 1425W, 120V (Includes item 4)
4	00943.0000	2	Gasket
5	00942.0000	2	Nut, Hex .50"-20
6	29329.1000	1	Limit Thermostat
7	04221.0000	1	Gasket, Tank Lid
8	28735.0000	1	Tank Lid
	00908.0000	8	Nut, Hex #8-32
9	02536.0000	1	Grommet
10	21801.0002	1	Tube, SST .375" O.D. x 1.50"
11	38969.0001	1	Fitting, Air Vent
12	07412.1002	1	Probe Kit, Liquid Level (Includes hardware below)
	00908.0000	1	Nut, Hex #8-32
	20203.0100	1	Lockwasher, Internal tooth #8
	01501.0000	1	Washer
13	33801.0003	1	Grommet
14	41179.1000	1	Probe, Temperature

* Indicates the part number listed is for reference only. See DESCRIPTION for possible service replacement.

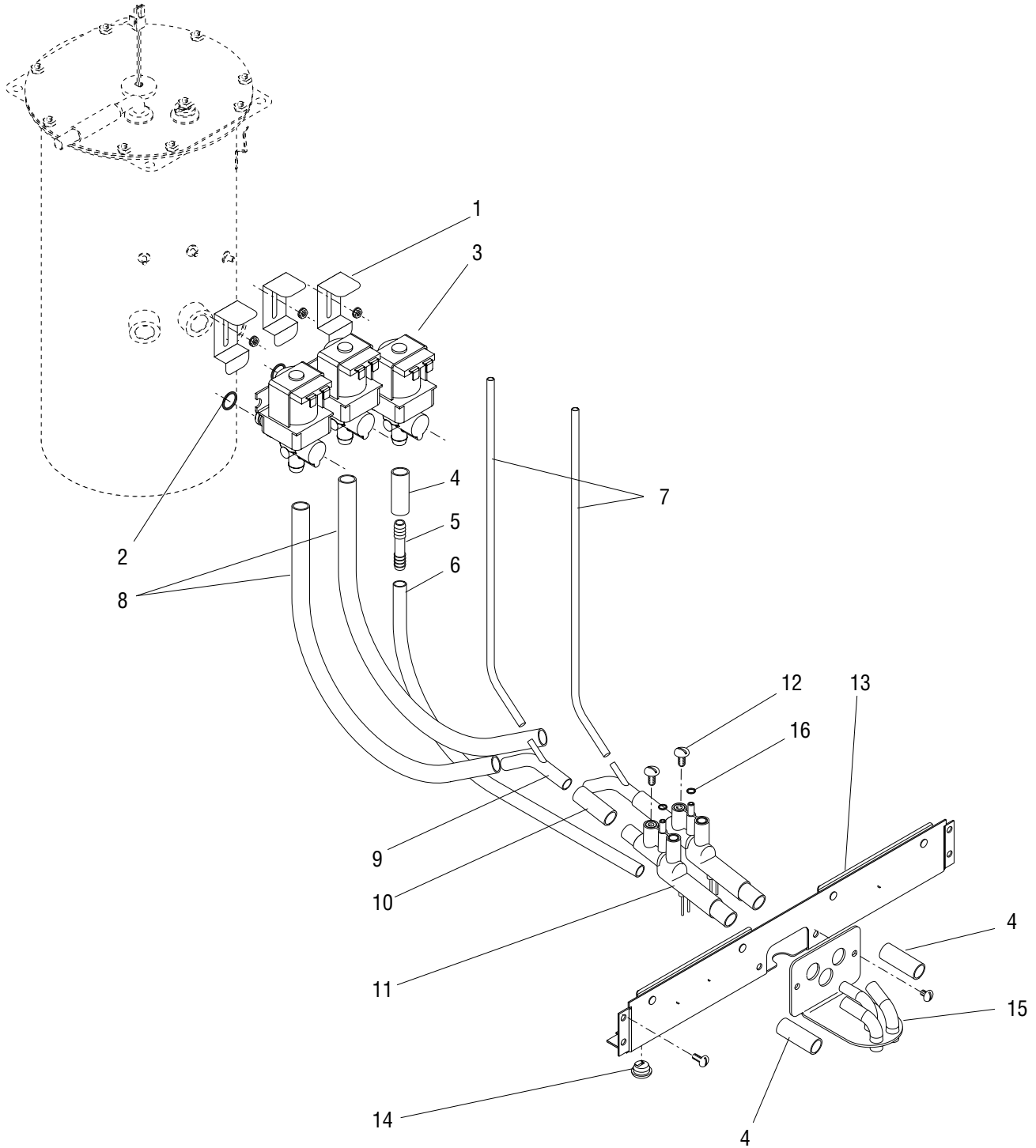

DISPENSE VALVE & MIXING CHAMBER

ITEM	PART NO.	QTY.	DESCRIPTION
1	29576.0000	3	Bracket, Valve Retaining
	00970.0000	3	Nut, Keps #8-32
2	24733.0011	3	O-ring
3	32345.1000	3	Valve, Dispense 120V (Refer to item 21)
4	20976.0062*	3	Tube, Silicone .375" ID x 1.75" (Order item 17)
5	34644.0000	1	Connector
6	11707.0010*	1	Tube, Silicone .25" ID x 16.0" (Order item 18)
7	36630.0001*	2	Tube, Silicone .125" ID x 20.0" (Order item 19)
8	28526.0000*	2	Tube, Silicone .313" ID x 11.5" (Order item 20)
9	37858.0000	2	Elbow, 45°
10	20976.0072*	2	Tube, Silicone .375" ID x 1.5" (Order item 17)
11	37854.1000	2	Mixing Chamber Assy (Includes item 16)
12	01326.0000	2	Screw, Truss Head #10-32 x .25"
13	36947.0001	1	Bracket, Lower Cabinet
	01315.0005	4	Screw, Truss Head BLK #8-32 x .38"
14	04822.0000	1	Bushing, Strain Relief
15	37807.0000	1	Bracket, Dispense Nozzle
	01315.0000	2	Screw, Truss Head #8-32 x .375"
16	40188.0000	2	O-ring
17	20976.1000	-	Tube, Silicone .375" ID x 12.0" (Use as required)
	20976.1001	-	Tube, Silicone .375" ID x 36.0" (Use as required)
	20976.1002	-	Tube, Silicone .375" ID x 120.0" (Use as required)
18	11707.1000	-	Tube, Silicone .25" ID x 12.0" (Use as required)
	11707.1001	-	Tube, Silicone .25" ID x 36.0" (Use as required)
	11707.1002	-	Tube, Silicone .25" ID x 120.0" (Use as required)
19	36630.1001	-	Tube, Silicone .125" ID x 36.0" (Use as required)
20	28526.1000	-	Tube, Silicone .313" ID x 12.0" (Use as required)
	28526.1001	-	Tube, Silicone .313" ID x 36.0" (Use as required)
	28526.1002	-	Tube, Silicone .313" ID x 60.0" (Use as required)
	28526.1003	-	Tube, Silicone .313" ID x 120.0" (Use as required)
21	32345.0050	-	Repair Kit (Includes Armature assy & Diaphragm)

* Indicates the part number listed is for reference only. See DESCRIPTION for possible service replacement.

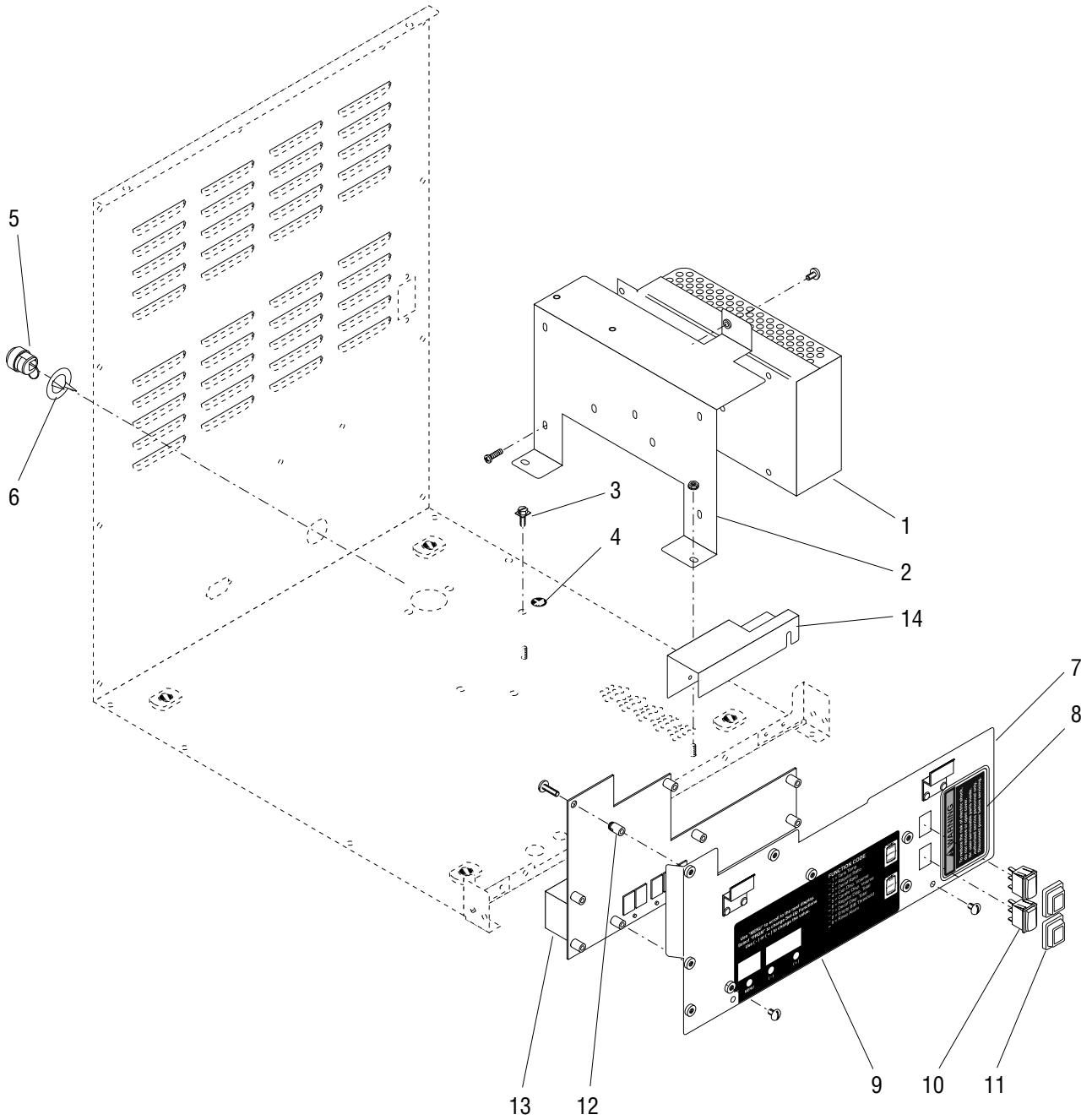

ELECTRICAL COMPONENTS

ITEM	PART NO.	QTY.	DESCRIPTION
1	33363.0001	1	Power Supply Module
	32283.0000	2	Screw, Pan Head M4 x 6.0 mm
2	37851.0000	1	Bracket
	00970.0000	2	Nut, Keps #8-32
	01315.0005	1	Screw, Truss Head BLK #8-32 x .38"
3	01309.0000	1	Screw, Grounding 120V
4	00824.0002	1	Decal, Ground Screw
5	00713.0000	1	Bushing, Strain Relief 120V
6	00715.0000	1	Adapter Washer, Strain Relief 120V
7	38771.1000	1	Bracket w/Decals, Circuit Board Mounting (Includes items 8 & 9)
	01311.0000	2	Screw, Truss Head #8-32 x .25"
8	37881.0000	1	Decal, No Serviceable Parts
9	37911.0001	1	Decal, Main Circuit Board Panel
10	27437.0001	2	Switch
11	34390.0000	2	Cap, Rocker Switch
12	29081.0001	8	Spacer
13	38726.1004	1	Circuit Board, Main
	01390.0000	7	Screw, Round Head #8-32 x .62"
14	46353.1001	1	Shield Kit
Items listed below are not illustrated			
15	37775.0000	1	Wiring Harness, Main 120V
16	20630.0008	1	Power Cord 120V
17	39269.0000	1	Wiring Harness, Fans 120V
18	39270.0000	1	Wiring Harness, Temp. Sensors 120V
19	00603.0000	1	Clamp
	01370.0000	1	Screw, Pan Head, Slt'd 8-32 x .75"
20	00617.0000	1	Cable Tie

* Indicates the part number listed is for reference only. See DESCRIPTION for possible service replacement.

NUMERICAL INDEX

PART NO.	PAGE NO.	PART NO.	PAGE NO.	PART NO.	PAGE NO.	PART NO.	PAGE NO.
00459.0000	17	21717.0000	9	34644.0000	23	37921.0003	5
00463.0000	17	21801.0002	17,19,21	34666.0001	11	38047.1000	7
00603.0000	13,25	21814.0016	17	34667.0000	9	44224.0000	9,11
00617.0000	11,15,25	22249.0000	17	34726.0004	13	38072.0000	9
00656.0001	5	23721.0000	17	34765.0000	15	38185.1000	5
00713.0000	25	23819.0000	17	34803.1000	11	38726.1000	25
00715.0000	25	23820.1000	17	34997.0000	15	38771.1000	25
00824.0002	5,25	24733.0011	23	34998.0000	15	38792.0000	9
00908.0000	21	25151.0008	5	35833.0000	13	38794.1000	9
00938.0000	17	26135.0005	17	36149.0000	7,15	38795.1002	9
00942.0000	21	26528.0000	5	36233.0000	19	38797.0002	11
00943.0000	21	26661.0000	17	36233.0001	19	38799.0000	13
00970.0000	9,13,21,23,25	27437.0001	25	36398.0000	5	38802.0000	13
00986.0002	5	28095.0000	5	36630.0001	23	38803.0000	13
01309.0000	25	28526.0000	17,19	36630.1001	23	38804.0000	13
01311.0000	13,25	28526.0009	17,19	36928.0000	15	38806.0000	13
01311.0001	15	28526.0029	17,19	36931.0000	21	38807.1001	11
01315.0000	9,11,13,23	28526.1000	17,19,23	36934.0000	21	38808.0000	13
01315.0005	5,7,13,17,23,25	28526.1001	17,19,23	36937.0000	9	38809.0001	13
01326.0000	13,23	28526.1002	17,19,23	36938.0001	5	38810.0000	11
01331.0004	15	28526.1003	17,19,23	36941.0000	5	38811.0000	13
01370.0000	25	28735.0000	21	36944.0000	5	38822.0000	13
01382.0000	9,13	28891.1000	13	36945.1000	5	38838.0000	9
01384.0002	13	29081.0001	25	36947.0001	23	38969.0001	21
01390.0000	25	29329.1000	21	37280.0000	9	39269.0000	25
01501.0000	21	29504.0004	7	37297.0006	19	39270.0000	25
01512.0000	15	29576.0000	23	37438.1002	9	39008.1000	9
01526.0001	5	32280.0000	13	37440.1000	9	40030.1000	15
01532.0000	17	32283.0000	19,25	37441.0000	9	40050.0001	15
02328.0003	15	32345.0050	23	37442.0001	9	40054.0000	7,9
02336.0000	15	32345.1000	23	37444.1001	9	40054.0001	9
02370.0001	11	32609.0000	15	37446.0000	9	40054.0002	7
02536.0000	21	32652.0000	15	37578.0001	5	40056.0004	19
02755.1000	21	32654.0000	15	37580.0000	15	40188.0000	23
03996.0000	5	32706.1000	15	37585.0000	9	40204.0000	11
04221.0000	21	32734.0000	13	37589.0001	5	40506.0006	19
04822.0000	9,23	32927.0000	15	37590.1000	5	41033.0000	9
07412.1002	21	32928.0000	15	37690.0000	9	41179.1000	21
12249.1002	7	32957.0000	15	37708.0003	5	41315.1000	5
11630.0001	19	33297.0002	13	37716.0001	5	42440.0000	7
11646.0002	9	33358.0000	11	37775.0000	25	42442.1000	5
11707.0010	23	33363.0001	25	37807.0000	23	46353.1001	25
11707.1000	23	33608.1000	15	37812.1000	21	48817.0000	11
11707.1001	23	33725.0000	19	37825.0000	9		
11707.1002	23	33801.0003	21	37826.0005	9		
12422.0001	19	33825.0000	15	37828.0000	9		
12422.0006	19	34010.0000	11	37829.1000	15		
12919.0005	17	34118.0001	5	37833.0001	9		
20203.0100	21	34166.1002	15	37846.1000	5		
20630.0008	25	34167.0000	15	37851.0000	25		
20976.0056	19	34265.1002	13	37854.1000	23		
20976.0062	23	34387.0000	9	37857.1750	19		
20976.0072	23	34387.0001	9	37858.0000	23		
20976.1000	19,23	34390.0000	25	37881.0000	5,25		
20976.1001	19,23	34472.0000	5	37911.0001	25		
20976.1002	19,23	34536.0001	15	37916.0000	9		