

# BUNN®

***LCR-2***  
***LCR-2A***  
***LCR-2 PC***  
***LCR-2A PC***

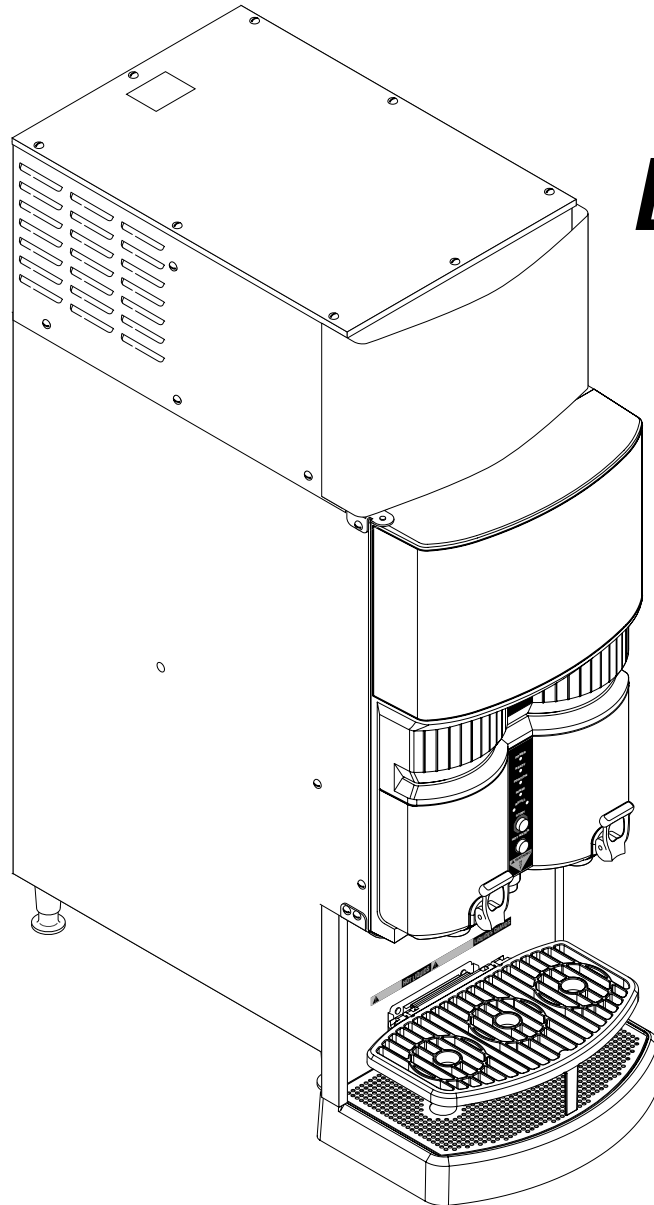

## **ILLUSTRATED PARTS CATALOG**

Designs, materials, weights, specifications, and dimensions for equipment or replacement parts are subject to change without notice.

**BUNN-O-MATIC CORPORATION**

POST OFFICE BOX 3227

SPRINGFIELD, ILLINOIS 62708-3227

PHONE: (217) 529-6601 FAX: (217) 529-6644



## BUNN-O-MATIC COMMERCIAL PRODUCT WARRANTY

Bunn-O-Matic Corp. ("BUNN") warrants equipment manufactured by it as follows:

- 1) Airpots, thermal carafes, decanters, GPR servers, iced tea/coffee dispensers, MCR/MCP/MCA single cup brewers, thermal servers and ThermoFresh® servers (mechanical and digital) 1 year parts and 1 year labor.
- 2) All other equipment - 2 years parts and 1 year labor plus added warranties as specified below:
  - a) Electronic circuit and/or control boards - parts and labor for 3 years.
  - b) Compressors on refrigeration equipment - 5 years parts and 1 year labor.
  - c) Grinding burrs on coffee grinding equipment to grind coffee to meet original factory screen sieve analysis - parts and labor for 4 years or 40,000 pounds of coffee, whichever comes first.

These warranty periods run from the date of installation BUNN warrants that the equipment manufactured by it will be commercially free of defects in material and workmanship existing at the time of manufacture and appearing within the applicable warranty period. This warranty does not apply to any equipment, component or part that was not manufactured by BUNN or that, in BUNN's judgment, has been affected by misuse, neglect, alteration, improper installation or operation, improper maintenance or repair, non periodic cleaning and descaling, equipment failures related to poor water quality, damage or casualty. In addition, the warranty does not apply to replacement of items subject to normal use including but not limited to user replaceable parts such as seals and gaskets. This warranty is conditioned on the Buyer 1) giving BUNN prompt notice of any claim to be made under this warranty by telephone at (217) 529-6601 or by writing to Post Office Box 3227, Springfield, Illinois 62708-3227; 2) if requested by BUNN, shipping the defective equipment prepaid to an authorized BUNN service location; and 3) receiving prior authorization from BUNN that the defective equipment is under warranty.

**THE FOREGOING WARRANTY IS EXCLUSIVE AND IS IN LIEU OF ANY OTHER WARRANTY, WRITTEN OR ORAL, EXPRESS OR IMPLIED, INCLUDING, BUT NOT LIMITED TO, ANY IMPLIED WARRANTY OF EITHER MERCHANTABILITY OR FITNESS FOR A PARTICULAR PURPOSE.** The agents, dealers or employees of BUNN are not authorized to make modifications to this warranty or to make additional warranties that are binding on BUNN. Accordingly, statements by such individuals, whether oral or written, do not constitute warranties and should not be relied upon.

If BUNN determines in its sole discretion that the equipment does not conform to the warranty, BUNN, at its exclusive option while the equipment is under warranty, shall either 1) provide at no charge replacement parts and/or labor (during the applicable parts and labor warranty periods specified above) to repair the defective components, provided that this repair is done by a BUNN Authorized Service Representative; or 2) shall replace the equipment or refund the purchase price for the equipment.

**THE BUYER'S REMEDY AGAINST BUNN FOR THE BREACH OF ANY OBLIGATION ARISING OUT OF THE SALE OF THIS EQUIPMENT, WHETHER DERIVED FROM WARRANTY OR OTHERWISE, SHALL BE LIMITED, AT BUNN'S SOLE OPTION AS SPECIFIED HEREIN, TO REPAIR, REPLACEMENT OR REFUND.**

In no event shall BUNN be liable for any other damage or loss, including, but not limited to, lost profits, lost sales, loss of use of equipment, claims of Buyer's customers, cost of capital, cost of down time, cost of substitute equipment, facilities or services, or any other special, incidental or consequential damages.

392, A Partner You Can Count On, Air Infusion, AutoPOD, AXIOM, BrewLOGIC, BrewMETER, Brew Better Not Bitter, BrewWISE, BrewWIZARD, BUNN Espresso, BUNN Family Gourmet, BUNN Gourmet, BUNN Pour-O-Matic, BUNN, BUNN with the stylized red line, BUNNlink, Bunn-O-Matic, Bunn-O-Matic, BUNNserve, BUNNSERVE with the stylized wrench design, Cool Froth, DBC, Dr. Brew stylized Dr. design, Dual, Easy Pour, EasyClear, EasyGard, FlavorGard, Gourmet Ice, Gourmet Juice, High Intensity, iMIX, Infusion Series, Intellisteam, My Café, Phase Brew, PowerLogic, Quality Beverage Equipment Worldwide, Respect Earth, Respect Earth with the stylized leaf and coffee cherry design, Safety-Fresh, savemycoffee.com, Scale-Pro, Silver Series, Single, Smart Funnel, Smart Hopper, SmartWAVE, Soft Heat, SplashGard, The Mark of Quality in Beverage Equipment Worldwide, ThermoFresh, Titan, trifacta, TRIFECTA (stylized logo), Velocity Brew, Air Brew, Beverage Bar Creator, Beverage Profit Calculator, Brew better, not bitter., Build-A-Drink, BUNNSource, Coffee At Its Best, Cyclonic Heating System, Daypart, Digital Brewer Control, Element, Milk Texturing Fusion, Nothing Brews Like a BUNN, Picture Prompted Cleaning, Pouring Profits, Signature Series, Sure Tamp, Tea At Its Best, The Horizontal Red Line, Ultra are either trademarks or registered trademarks of Bunn-O-Matic Corporation. The commercial trifacta® brewer housing configuration is a trademark of Bunn-O-Matic Corporation.

# TABLE OF CONTENTS

TITLE	PAGE NO.
Housing & Panels .....	4
Door Assembly (Early Models) .....	8
Door Assembly (Late Models).....	8
Cabinet Assembly .....	12
Refrigeration Compartment.....	14
Compressor & Lines .....	16
Compressor Assembly.....	18
Tank Assembly .....	20
Dispense Valves & Lines.....	24
Pump Assembly.....	28
Electrical Controls .....	30
Numerical Index.....	36

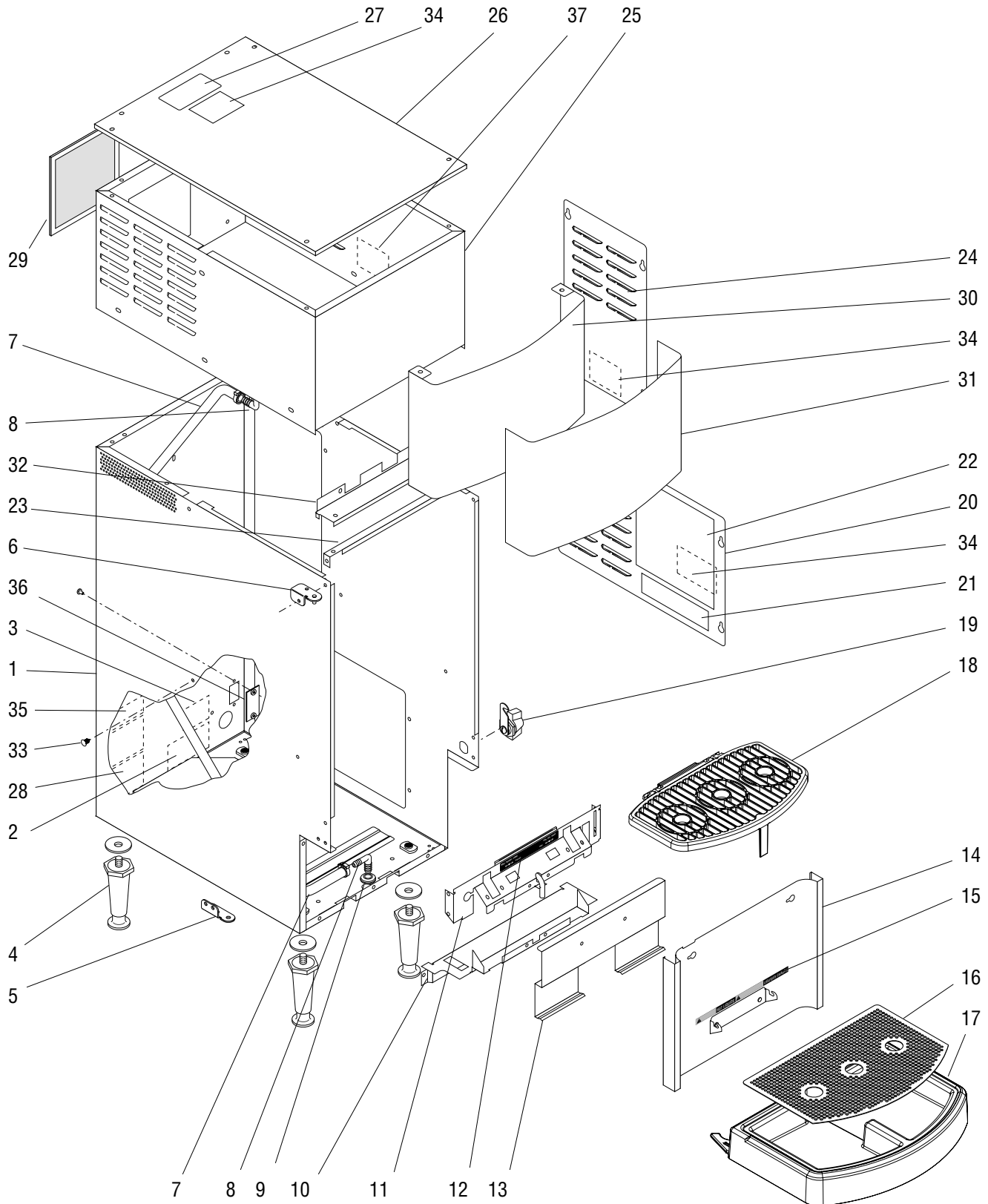

## HOUSING & PANELS

ITEM	PART NO.	QTY.	DESCRIPTION
1	35825.0001*	1	Housing Assy BLK Single Piece (Not serviced. Order Decals separately)
	42276.0000*	1	Housing Assy BLK Multi Piece (Not serviced. Order Decals separately)
	01311.0003	29	Screw, Truss Head, Sltd. Blk #8-32 x .25" (Used to join panels & base)
2	00656.0001	1	Decal, Comply to Plumbing Code
3	00986.0002	1	Decal, Warning - Electrical
4	26528.0000	4	Leg 4.0" adj.
	01526.0001	4	Washer, Flat
5	34335.0002	1	Hinge, Lower Door
	01315.0005	2	Screw, Truss Head, Sltd. Blk #8-32 x .38"
6	34385.0001	1	Hinge, Upper Door .25" Pin length (Early model doors w/Bushing)
	34385.0003	1	Hinge, Upper Door .375" Pin length (Late model doors w/o Bushing)
	01315.0005	2	Screw, Truss Head, Sltd. Blk #8-32 x .38"
7	11707.0040*	1	Tube, Silicone .25" ID x 35.0" (Order item 39)
	28526.0020*	1	Tube, Silicone .313" ID x 35.0" (Order item 40)
	12422.0000	2	Clamp, Snap-Type .47/.54" I.D.
	12422.0001	2	Clamp, Snap-Type .59/.66" I.D.
8	32656.0000	2	Elbow .25" x .38" Barb (Early models w/ .25" ID Tube)
	37850.0000	2	Elbow .38" x .38" Barb (Late models w/ .313" ID Tube)
9	02536.0000	1	Grommet
10	34152.0003	1	Bracket
	01311.0003	3	Screw, Truss Head, Sltd. Blk #8-32 x .25"
	01382.0000	2	Screw, Truss Head, Sltd. Blk #6-32 x .38"
11	35188.0000	1	Bracket
	01315.0005	4	Screw, Truss Head, Sltd. Blk #8-32 x .38"
12	34783.0000	1	Decal, Dispense Platform
13	34366.0000	1	Bracket (Early Models)
14	39999.1000	1	Splash Panel w/Decal (Includes item 15)
	01315.0005	2	Screw, Truss Head, Sltd. Blk #8-32 x .38"
15	11646.0002	1	Decal, Warning - Hot Liquids
16	34379.0002	1	Cover, Drip Tray (See item 38)
17	38433.0000	1	Drip Tray (See item 38)
18	34821.1000	1	Cup Tray
19	34472.1000	1	Lock, Door (Includes Keys)
	28095.0000	1	Key Set
20	34186.1006	1	Panel w/Decals, Lower Access (Includes items 21, 22 & 34)
	01315.0005	4	Screw, Truss Head, Sltd. Blk #8-32 x .38"
21	34960.0000	1	Decal, Terminal Block Wiring (Not used on 3 Phase models)
	39762.0000	1	Decal, Terminal Block Wiring (Used on 3 Phase models)
	34960.0001	1	Decal, Terminal Block Wiring (Models w/ Master ON/OFF Switch)

(Continued)

\* Indicates the part number listed is for reference only. See DESCRIPTION for possible service replacement.

(Continued)

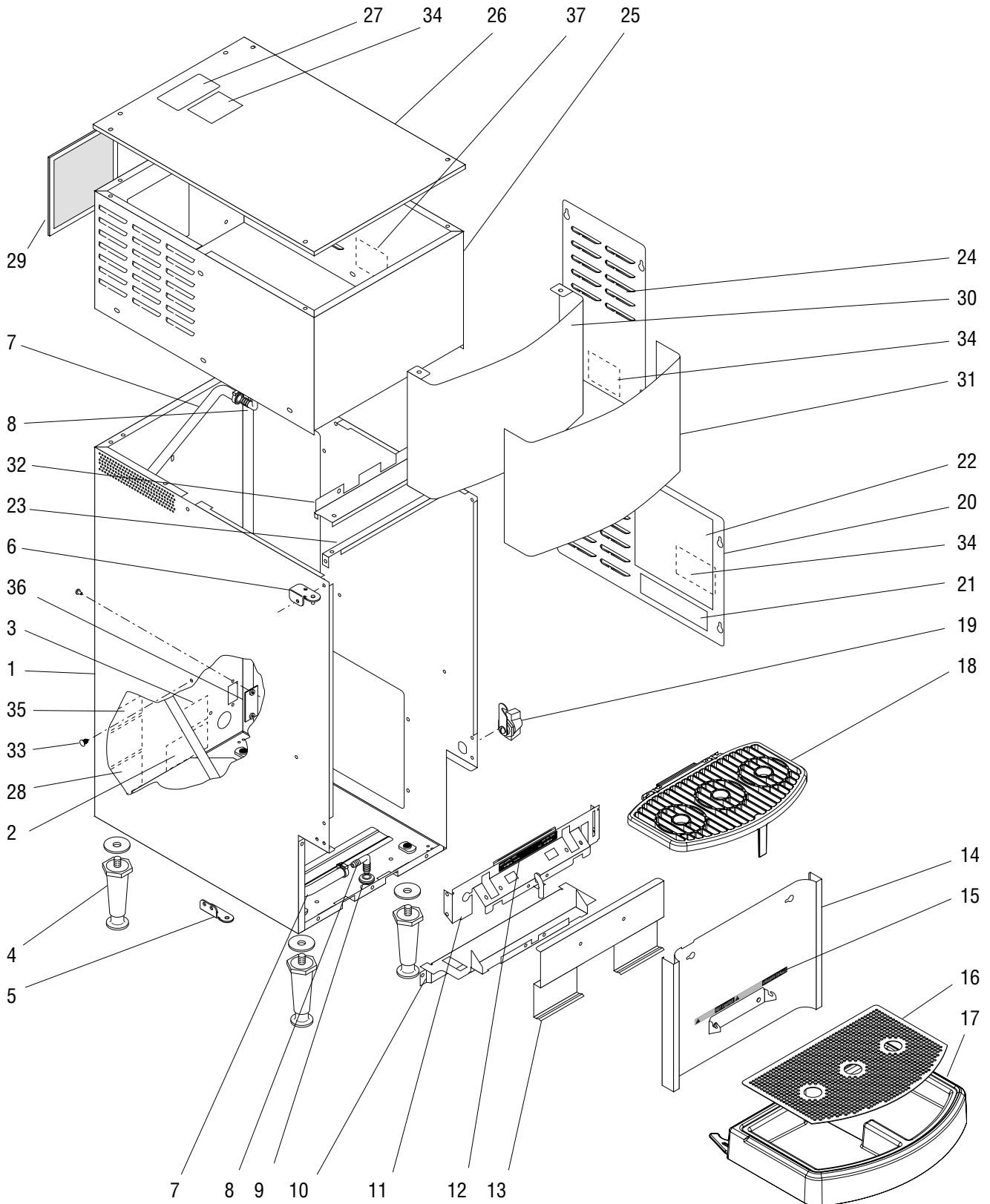

## HOUSING & PANELS

ITEM	PART NO.	QTY.	DESCRIPTION
22	36025.0004	1	Schematic, Electrical (LCR-2, LCR-2C)
	36025.0001	1	Schematic, Electrical (LCR-2A)
	36025.0002	1	Schematic, Electrical (LCR-2A 3 Phase models)
23	34190.0000	1	Brace
	01311.0003	2	Screw, Truss Head, Sltd. Blk #8-32 x .25"
24	34194.1001	1	Panel w/Decal, Upper Access (Includes item 34)
	01315.0005	4	Screw, Truss Head, Sltd. Blk #8-32 x .38"
25	35883.0003	1	Housing, Refrigeration
	01315.0005	6	Screw, Truss Head, Sltd. Blk #8-32 x .38"
26	35884.1003	1	Cover, Top (Includes items 27 & 34)
	01315.0005	6	Screw, Truss Head, Sltd. Blk #8-32 x .38"
27	27442.0000	1	Decal, Warning - Moving Parts
28	28181.0003	1	Decal, Optional Field Wiring 120/208-240V
	29710.0014	1	Decal, Optional Field Wiring 230V
29	35833.0000	1	Filter, Air
30	35890.0001	1	Panel, Merchandise
31	36011.0000	1	Decal, Upper Hood
32	35829.0001	1	Cover, Top Front
	01315.0005	2	Screw, Truss Head, Sltd. Blk #8-32 x .38"
33	36149.0000	2	Fastener
34	37881.0000	3	Decal, No Serviceable Parts
35	33461.0008	1	Decal, Refrigerant Charge 4 oz
36	38820.0000	1	Plate, Cover (Not used on models w/ Master ON/OFF Switch)
	01308.0003	2	Screw, Truss Head, Locking BLK #6-32 x .25"
37	40054.0003	1	Decal, Clean Air Filter
38	34893.0001	-	Drip Tray Kit (Includes items 16 & 17)
39	11707.1000	-	Tube, Silicone .25" ID x 12.0" (Use as required)
	11707.1001	-	Tube, Silicone .25" ID x 36.0" (Use as required)
	11707.1002	-	Tube, Silicone .25" ID x 120.0" (Use as required)
40	28526.1000	-	Tube, Silicone .313" ID x 12.0" (Use as required)
	28526.1001	-	Tube, Silicone .313" ID x 36.0" (Use as required)
	28526.1002	-	Tube, Silicone .313" ID x 120.0" (Use as required)

} Not Illustrated

\* Indicates the part number listed is for reference only. See DESCRIPTION for possible service replacement.

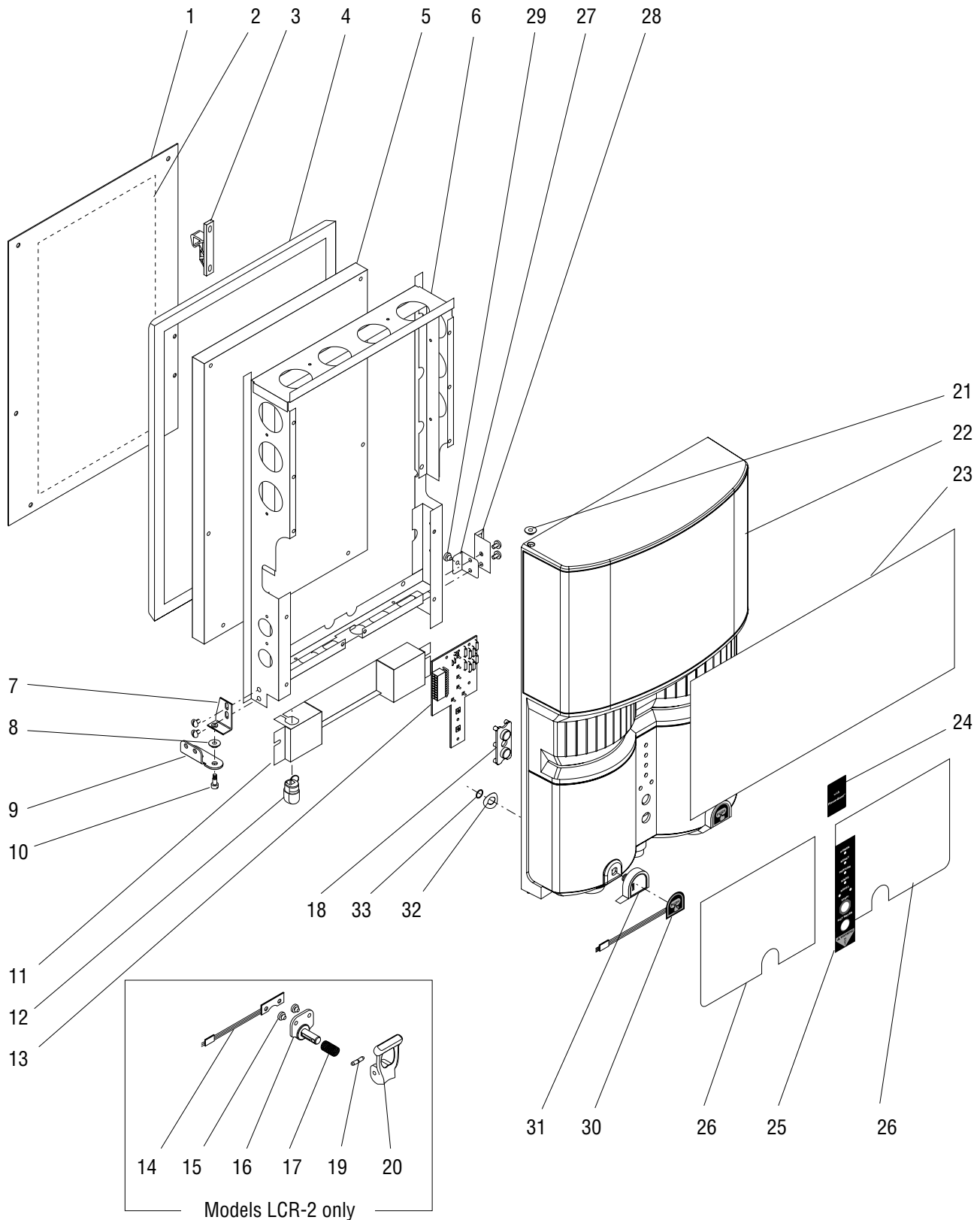



## DOOR ASSEMBLY (Early Models)

ITEM	PART NO.	QTY.	DESCRIPTION	
-	34284.1011	1	Door Assembly, Standard Controls (Includes items 6,7,10,13 & 14 - 26)	
	34284.1012	1	Door Assembly, Portion Control (Includes items 6,7,10,13,14,18, 21 - 26 & 30 - 33)	
1	34531.1000	1	Plate w/Decal (Includes item 2)	
	01322.0001	6	Screw, Round Head Sltd. #8-32 x 1.25"	
2	34809.0001	1	Decal, Maintenance	
3	34667.0000	1	Keeper, Door Latch	
	01382.0000	2	Screw, Truss Head Sltd. #6-32 x .38"	
4	34150.0000	1	Seal, Product Cabinet	
5	34473.0000	1	Insulation, Door	
6	34361.0000*	1	Frame, Door (Not Serviced)	
7	34334.0000	1	Bracket	
	01311.0000	2	Screw, Truss Head Sltd. #8-32 x .25"	
8	34362.0000	1	Bushing, Lower Hinge	
9	-----	1	Lower Door Hinge (See HOUSINGS & PANELS)	
10	29504.0004	1	Shoulder Screw #8-32	
11	34527.0000	1	Panel	
	44224.0000	2	Screw, Pan Head #6-20 X .38"	
12	26444.0000	1	Bushing, Strain Relief	
13	38735.1000	1	Circuit Board, LED	
	44224.0000	2	Screw, Pan Head #6-20 X .38"	
14	33039.0001	2	Switch, Membrane	} Models LCR-2 with Standard Controls
15	34340.1000	1	Button Kit (Includes two buttons)	
16	34341.1000	2	Stem, Handle	
17	34742.0000	2	Spring	
18	34387.0000	1	Cover, Switch	} Models LCR-2 with Standard Controls
19	01219.0000	2	Pin, Faucet Handle	
20	33434.1000	1	Handle, Black	
	33434.1002	1	Handle, Orange	} Includes item 19
21	34362.0001	1	Bushing, Upper Hinge (Early models only)	
22	34283.0002	1	Door Front	
	44224.0000	13	Screw, Pan Head #6-20 X .38"	
23	34708.0000	1	Decal, Upper Door Wrap	
24	34712.0000	1	Decal, Flavor Gard	
25	34711.0000	1	Decal, LED Display	

(Continued)

\* Indicates the part number listed is for reference only. See DESCRIPTION for possible service replacement.

(Continued)

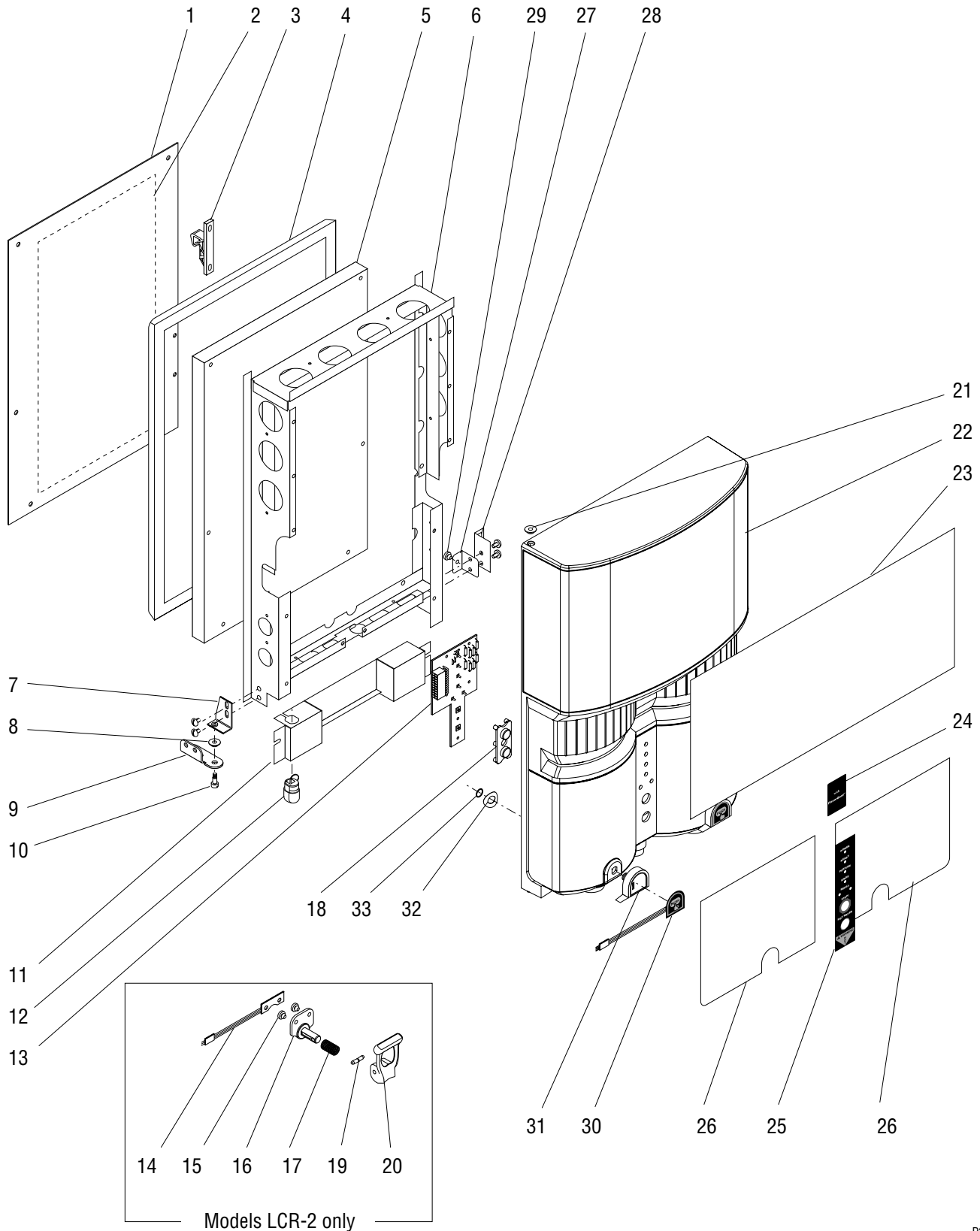

## DOOR ASSEMBLY (Early Models)

ITEM	PART NO.	QTY.	DESCRIPTION	
26	34709.0000	1	Decal, Left Faux Server	
	34710.0000	1	Decal, Right Faux Server	
27	35087.0000	1	Bracket, Switch	
	01311.0000	2	Screw, Truss Head Sltd. #8-32 x .25"	
28	36012.0000	1	Bracket, Latch	
29	34340.0000*	1	Button	
30	36554.0000	2	Membrane Switch	] Models LCR-2, PC & LCR-2A, PC with Portion Controls
31	36673.0000	2	Bezel	
32	36785.0000	2	Washer, Wavy	
33	36786.0000	2	Snap Ring	

\* Indicates the part number listed is for reference only. See DESCRIPTION for possible service replacement.

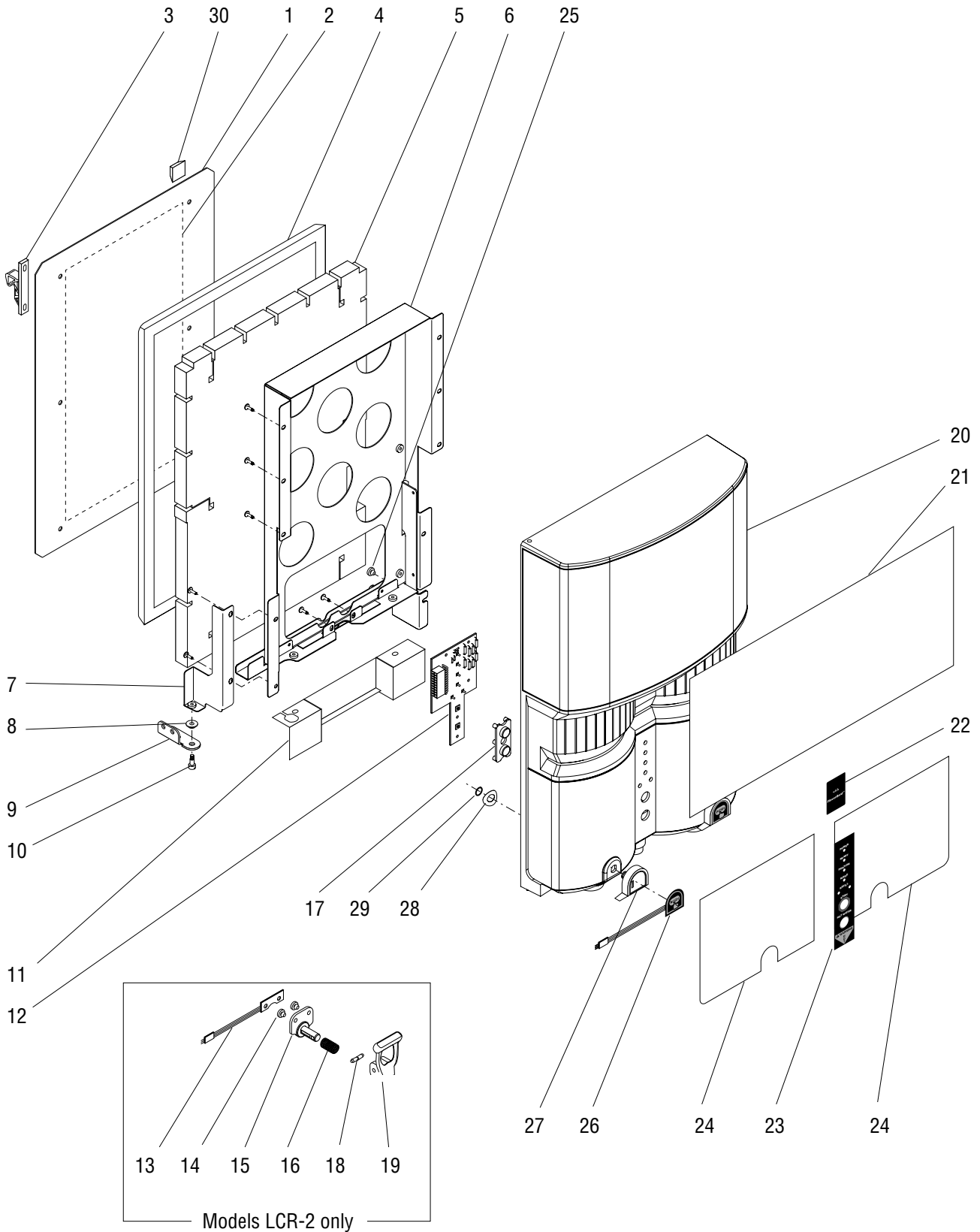

## DOOR ASSEMBLY (Late Models)

ITEM	PART NO.	QTY.	DESCRIPTION	
-	41925.0011	1	Door Assembly, Standard Controls (Includes items 6,7,10 & 12 - 24)	
	41925.1012	1	Door Assembly, Portion Control (Includes items 6,7,10,12,14,17, 20 - 29)	
1	40095.1000	1	Plate w/Decal (Includes item 2)	
	01322.0001	6	Screw, Round Head Sltd. #8-32 x 1.25"	
2	34809.0001	1	Decal, Maintenance	
3	34667.0001	1	Keeper, Door Latch	
	01382.0000	2	Screw, Truss Head Sltd. #6-32 x .38"	
4	41512.0000	1	Seal, Product Cabinet	
5	40092.0000	1	Insulation, Door	
6	40087.0000*	1	Frame, Door (Not Serviced)	
7	40091.0000	1	Bracket	
	01311.0000	2	Screw, Truss Head Sltd. #8-32 x .25"	
8	34362.0000	1	Bushing, Lower Hinge	
9	-----	1	Lower Door Hinge (See HOUSINGS & PANELS)	
10	29504.0004	1	Shoulder Screw #8-32	
11	40094.0000	1	Panel	
	01311.0000	2	Screw, Truss Head Sltd. #8-32 x .25"	
12	38735.1000	1	Circuit Board, LED	
	44224.0000	2	Screw, Pan Head #6-20 X .38"	
13	33039.0001	2	Switch, Membrane	} Models LCR-2 with Standard Controls
14	34340.1000	1	Button Kit (Includes two buttons)	
15	34341.1000	2	Stem, Handle	
16	34742.0000	2	Spring	
17	34387.0000	1	Cover, Switch	
18	01219.0000	2	Pin, Faucet Handle	} Models LCR-2 with Standard Controls
19	33434.1000	1	Handle, Black	
	33434.1002	1	Handle, Orange } Includes item 19	
20	34283.0002	1	Door Front (Not serviced separately)	
	44224.0000	13	Screw, Pan Head #6-20 X .38"	
21	34708.0000	1	Decal, Upper Door Wrap	
22	34712.0000	1	Decal, Flavor Gard	
23	34711.0000	1	Decal, LED Display	
24	34709.0000	1	Decal, Left Faux Server	
	34710.0000	1	Decal, Right Faux Server	
25	34340.0000*	1	Button	
26	36554.0000	2	Membrane Switch	
27	36673.0000	2	Bezel	} Models LCR-2 PC & LCR-2A PC with Portion Controls
28	36785.0000	2	Washer, Wavy	
29	36786.0000	2	Snap Ring	
30	02547.0000	1	Foot, Rubber	

\* Indicates the part number listed is for reference only. See DESCRIPTION for possible service replacement.

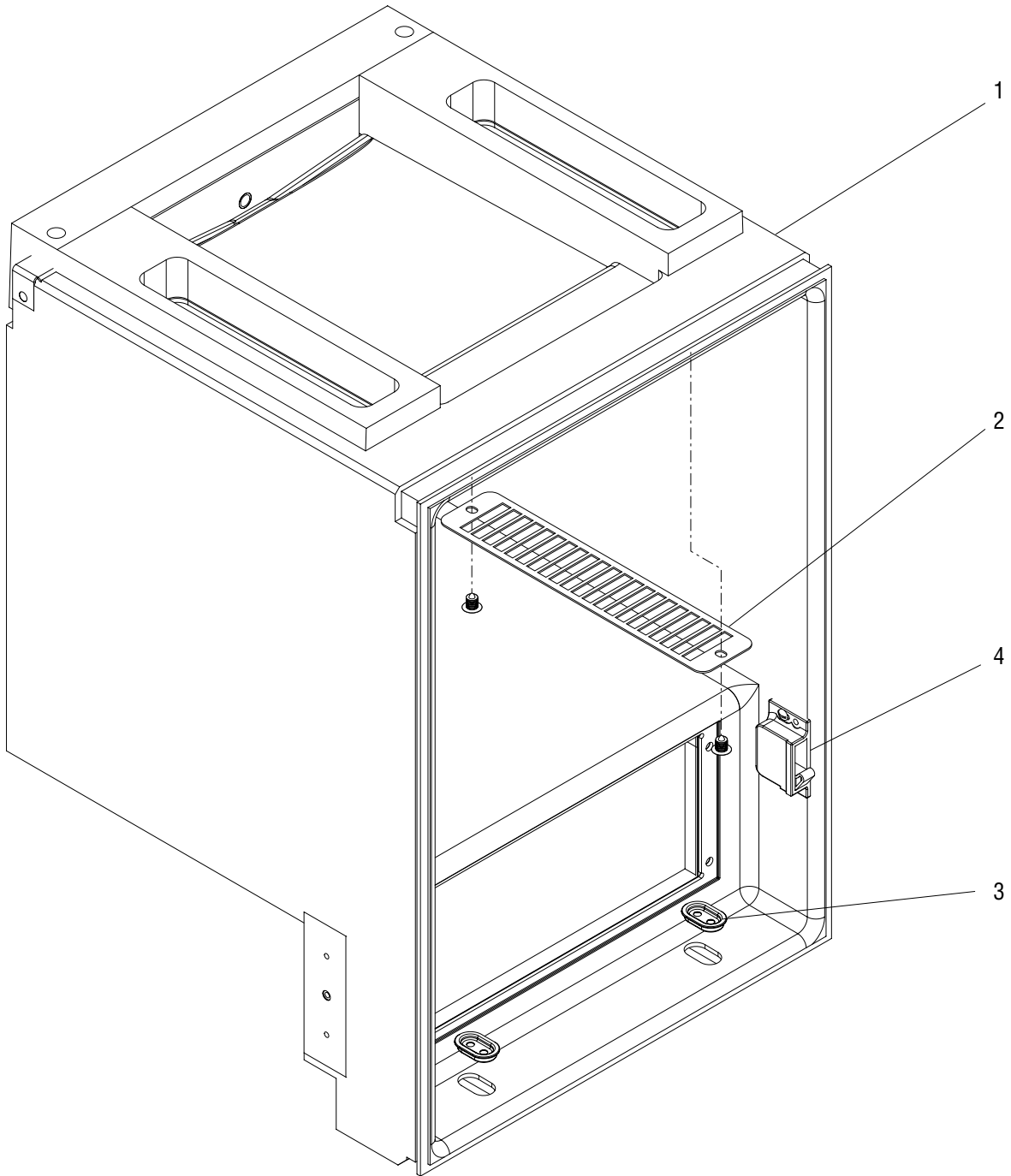

## CABINET ASSEMBLY

ITEM	PART NO.	QTY.	DESCRIPTION
1	36113.1001	1	Cabinet
2	35959.0000*	2	Cover, Vent
	36149.0000	4	Fastener
3	34702.0000	2	Grommet
4	34666.0001	1	Catch
	48817.0000	2	Screw, Pan Head #4-40 x .50"

\* Indicates the part number listed is for reference only. See DESCRIPTION for possible service replacement.

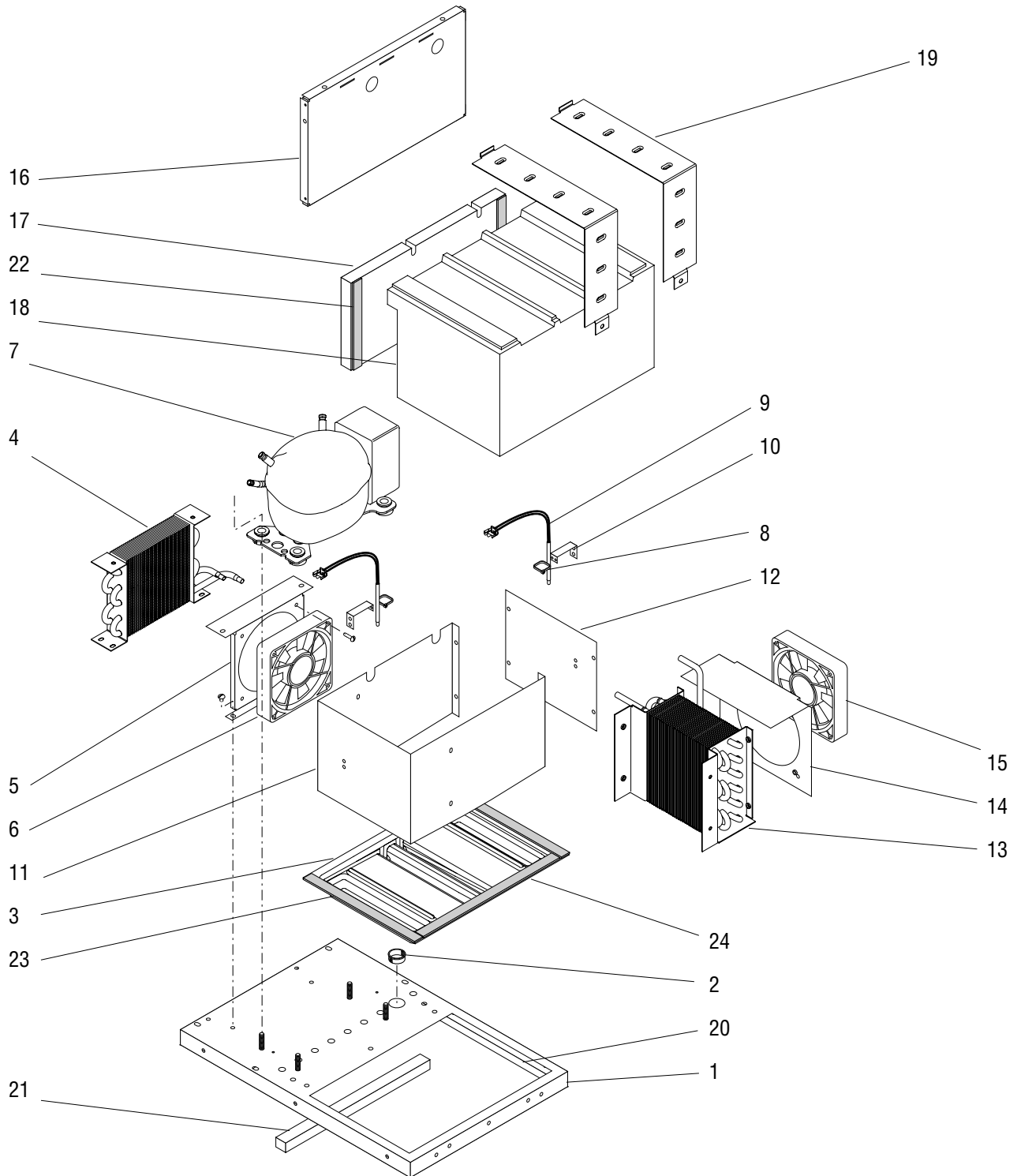



## REFRIGERATION COMPARTMENT

ITEM	PART NO.	QTY.	DESCRIPTION
-	36077.0001	1	Refrigeration Assembly (Includes item 1- 24)
1	35827.0000	1	Base
	01326.0008	2	Screw, Truss Head, Sltd.,Blk #10-32 x 1.25"
	01384.0000	4	Screw, Truss Head Sltd. SST #8-32 x 1.5"
2	00606.0000	1	Bushing, Snap
3	35830.0000	1	Drip Tray
4	35821.0001*	1	Condenser
	02335.0001	2	Screw, Hex Crimptite #8-32 x .375"
5	35887.0000	1	Bracket
	01311.0000	2	Screw, Truss Head #8-32 x .25"
6	33297.0002	1	Fan
	02370.0003	4	Screw, Pan Head #6-32 x 1.50"
7	-----	1	Compressor Assy. (See COMPRESSOR ASSEMBLY)
	21431.0003	4	Washer
	00901.0000	4	Nut, Hex .250"-20
8	00617.0000	2	Cable Tie
9	34803.1000	2	Sensor Assembly
10	36016.0000	2	Bracket
	01382.0000	4	Screw, Truss Head #6-32 x .38"
11	35834.0000	1	Housing
12	35891.0000	1	Panel
	01311.0000	4	Screw, Truss Head #8-32 x .25"
13	35823.0001*	1	Evaporator
	02335.0001	2	Screw, Hex Crimptite #8-32 x .375"
14	35888.0000	1	Bracket
	01311.0000	4	Screw, Truss Head #8-32 x .25"
15	33297.0002	1	Fan
	02370.0003	4	Screw, Pan Head #6-32 x 1.50"
16	35838.0000	1	Panel
	01327.0000	3	Screw, Pan Head #10-32 x .38"
17	35965.0000	1	Panel, Styrofoam - Back
18	38301.0001*	1	Panel, Styrofoam
19	35836.0000	2	Strap
	01311.0000	2	Screw, Truss Head #8-32 x .25"
20	36117.0000	1	Insulation, 30.0"
21	36118.0000	1	Insulation, 11.9"
22	22462.0007*	2	Gasket, 5.25" (Order item 28)
23	22462.0015*	2	Gasket, 7.75" (Order item 28)
24	22462.0016*	2	Gasket, 11.50" (Order item 28)

The following items are not illustrated:

25	36037.0000	1	Wiring Harness - Compressor Module
26	36050.0001	1	Wiring Harness - Compressor Speed Control
27	36056.0000	1	Wiring Harness - Sensors
28	22462.1000	-	Gasket, 24.0" (Cut to required length)

\* Indicates the part number listed is for reference only. See DESCRIPTION for possible service replacement.

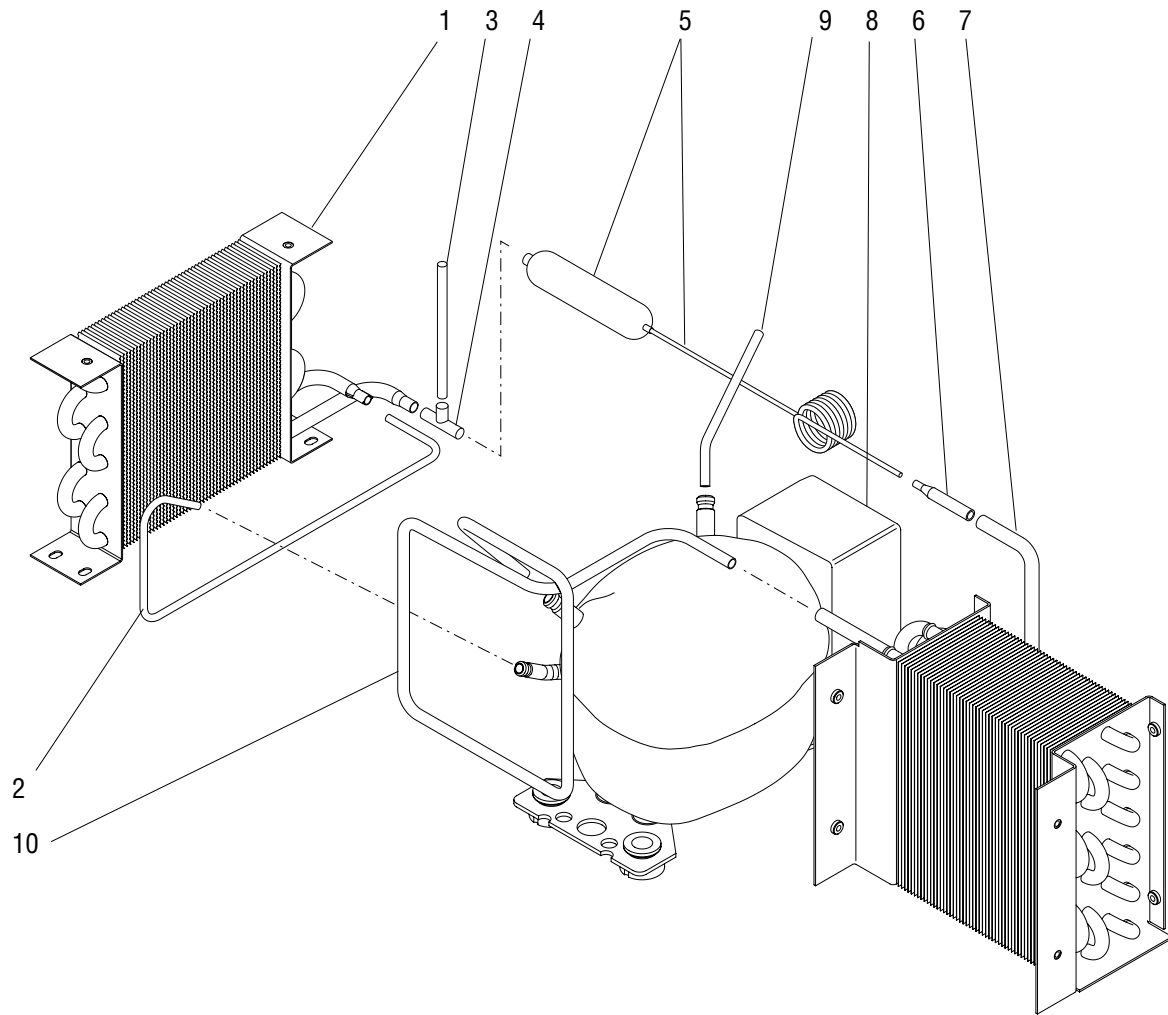

## COMPRESSOR & LINES

ITEM	PART NO.	QTY.	DESCRIPTION
1	-----	1	Condenser Assembly (See REFRIGERATION COMPARTMENT)
2	36021.0001*	1	Tube (Requires brazing to install)
3	35581.0001	1	Tube (Requires brazing to install)
4	00467.0000*	1	Tee (Requires brazing to install)
5	35820.0000	1	Filter Dryer Assembly (Requires brazing to install)
6	36010.0000*	1	Adapter (Requires brazing to install)
7	-----	1	Evaporator Assembly (See REFRIGERATION COMPARTMENT)
8	-----	1	Compressor Assembly (See COMPRESSOR ASSEMBLY)
9	36019.0001	1	Tube (Requires brazing to install)
10	36308.0001*	1	Tube (Requires brazing to install)

The following items are not illustrated:

11	-----	1	Tape, Cork - Pipe Insulating 2.00' (Early models)(Order item 12)
12	M2336.1000	-	Insulation, Tube 72.0" (Use as required)

\* Indicates the part number listed is for reference only. See DESCRIPTION for possible service replacement.

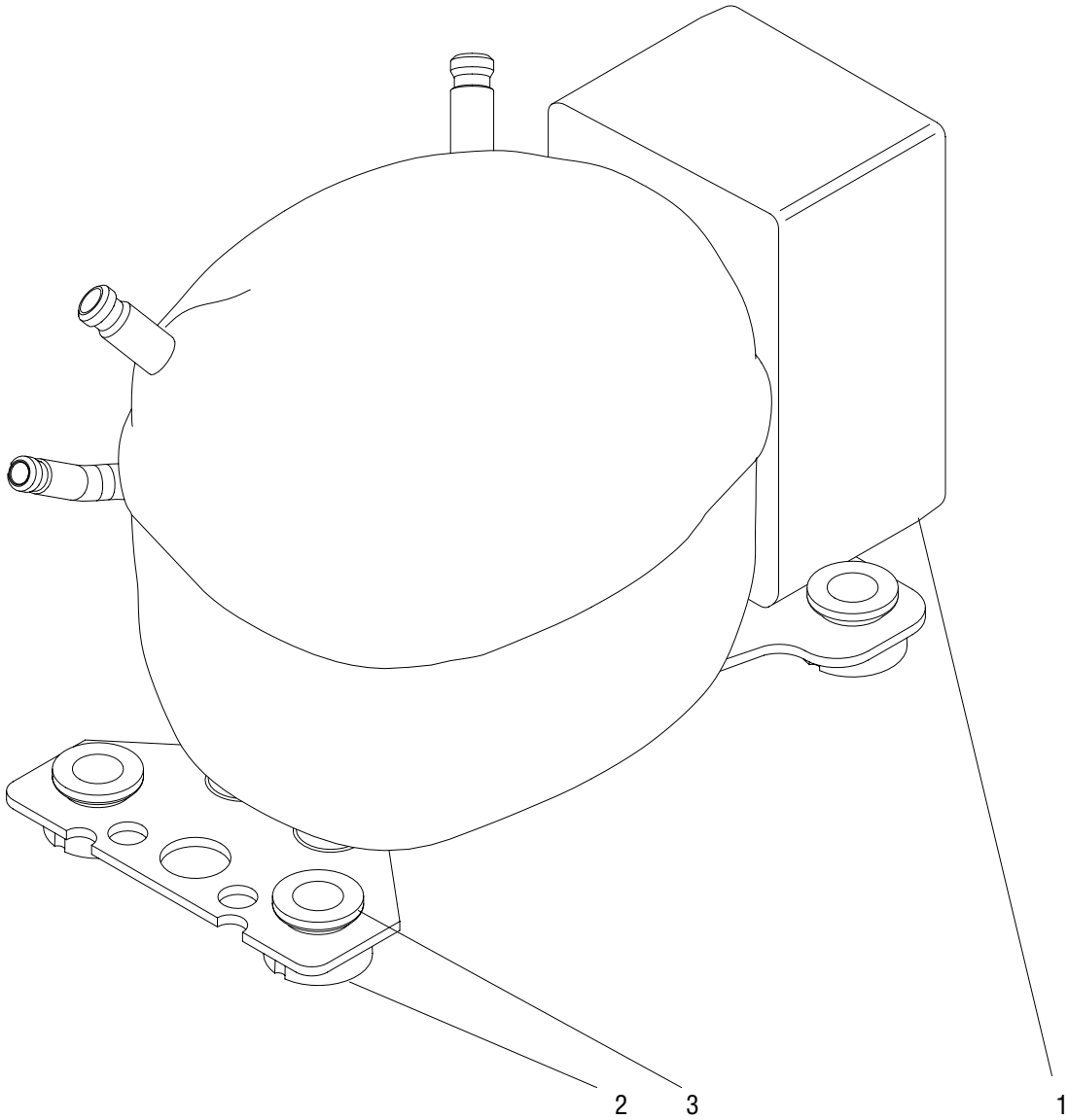

## COMPRESSOR ASSEMBLY

ITEM	PART NO.	QTY.	DESCRIPTION
-	35822.0000*	1	Compressor Assembly (Model BD-50F) (Includes items 1 - 3)
	35822.0001*	1	Compressor Assembly (Model BD-35F) (Includes items 1 - 3)
1	35961.0000	1	Electronics Box
2	35962.0000	4	Grommet
3	35963.0000	4	Sleeve

\* Indicates the part number listed is for reference only. See DESCRIPTION for possible service replacement.

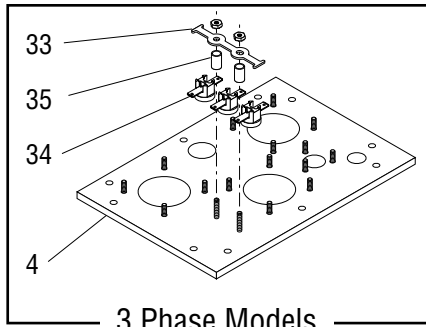

3 Phase Models

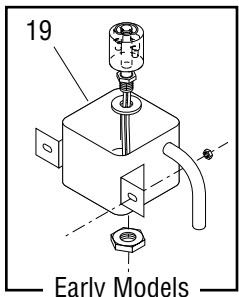
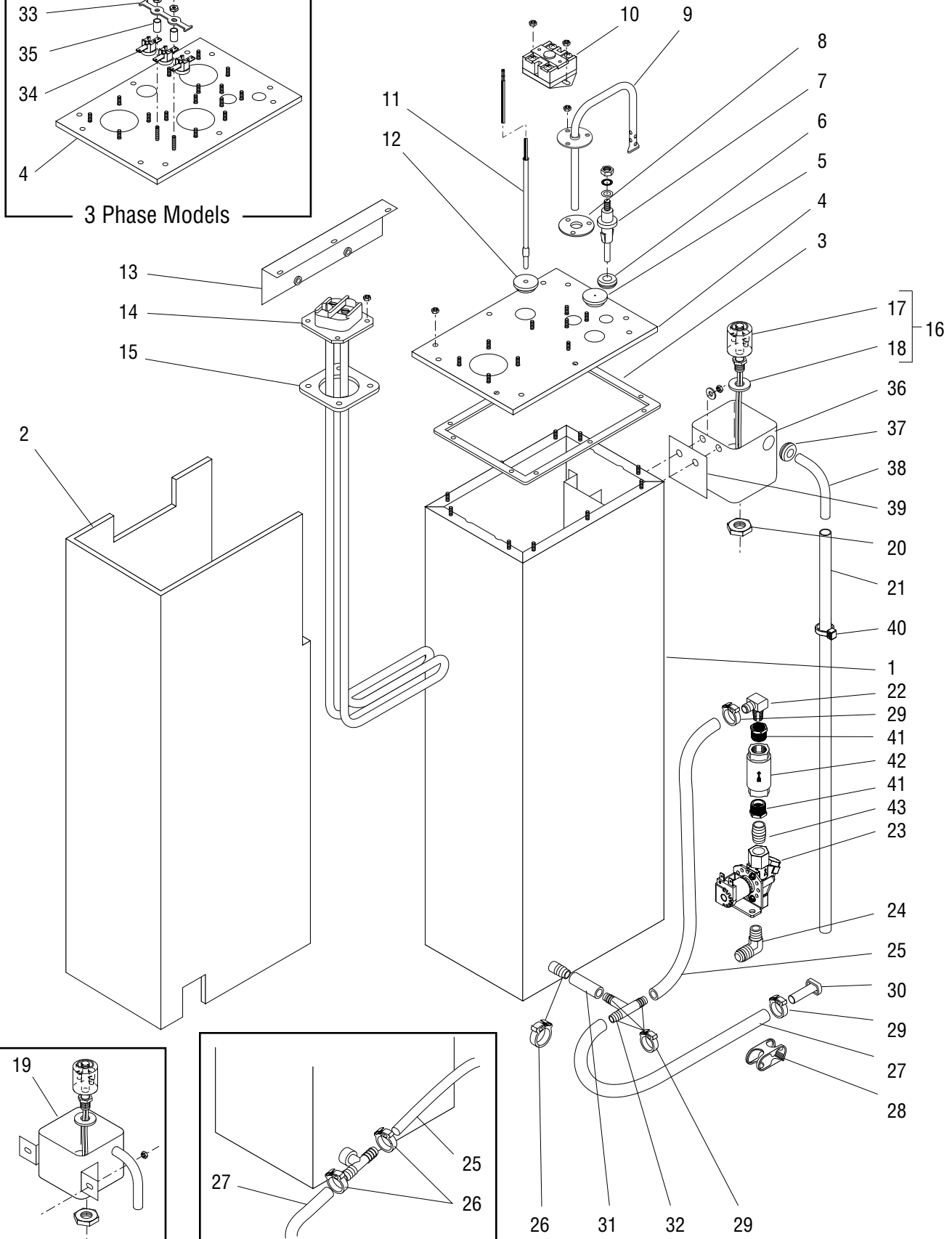

Early Models

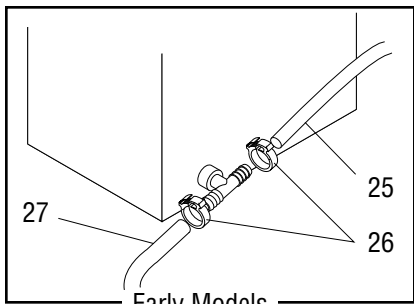

Early Models

## TANK ASSEMBLY

ITEM	PART NO.	QTY.	DESCRIPTION
1	34158.1002	1	Tank
2	-----	1	Insulation, Tank Wrap (Early Models. Not Available)
3	12377.0000	1	Gasket, Tank Lid
4	34160.0000	1	Lid, Tank
	34160.0001	1	Lid, Tank (3 Phase models)
	00906.0000	10	Nut #6-32
5	07073.0001	1	Grommet, Thermostat (Models with thermostat)
	12570.0002	1	Grommet (Models without thermostat)
6	02536.0000	1	Grommet, Level Probe
7	20936.1000	1	Probe, Liquid Level
	01501.0000	1	Washer
	20203.0100	1	Lockwasher, Int.-tooth #8
	00908.0000	1	Nut #8-32
8	05515.0000	1	Gasket, Overflow Tube
9	26622.0002*	1	Tube, Overflow
	00908.0000	3	Nut #8-32
10	23717.0003	1	Limit Thermostat, Double
	00971.0000	2	Nut, Keps #10-32
11	41179.1000	1	Probe, Temperature
12	12570.0000	1	Grommet, Temperature Probe
13	34895.0000	1	Bracket
	01315.0005	2	Screw, Truss Head Sltd. Blk #8-32 x .38"
14	33926.1001	1	Tank Heater, 5500W 240V (Includes item 15)
	12322.1000	1	Tank Heater, 4000W 240V (Includes item 15)
	38818.1000	3	Tank Heater, 3000W 240V (Includes item 15) (3 Phase models)
	00908.0000	4	Nut #8-32 (8 additional used on 3 Phase models)
15	12398.0002	1	Gasket, Tank Heater
16	03803.0002	1	Switch, Overflow (Includes items 17 & 18)
17	03807.0000	1	Retaining Ring
18	03633.0000	1	Gasket, Silicone
19	22728.0002	1	Overflow Cup
	00970.0000	2	Nut, Keps #8-32 } Early Models
20	00946.0000	1	Nut, Brass .125"-27
21	20976.0067*	1	Tube, Silicone .375" ID x 21.0" (Order item 44)
22	34684.0000	1	Elbow .375" Barb x .375" NPT
23	33418.0001	1	Valve, Water Inlet
	01326.0000	2	Screw, Truss Head Sltd. #10-32 x .25"

(Continued)

\* Indicates the part number listed is for reference only. See DESCRIPTION for possible service replacement.

(Continued)

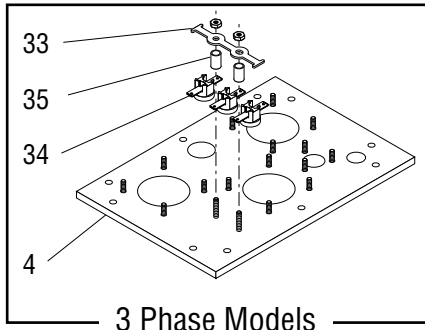

3 Phase Models

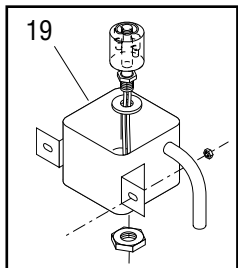
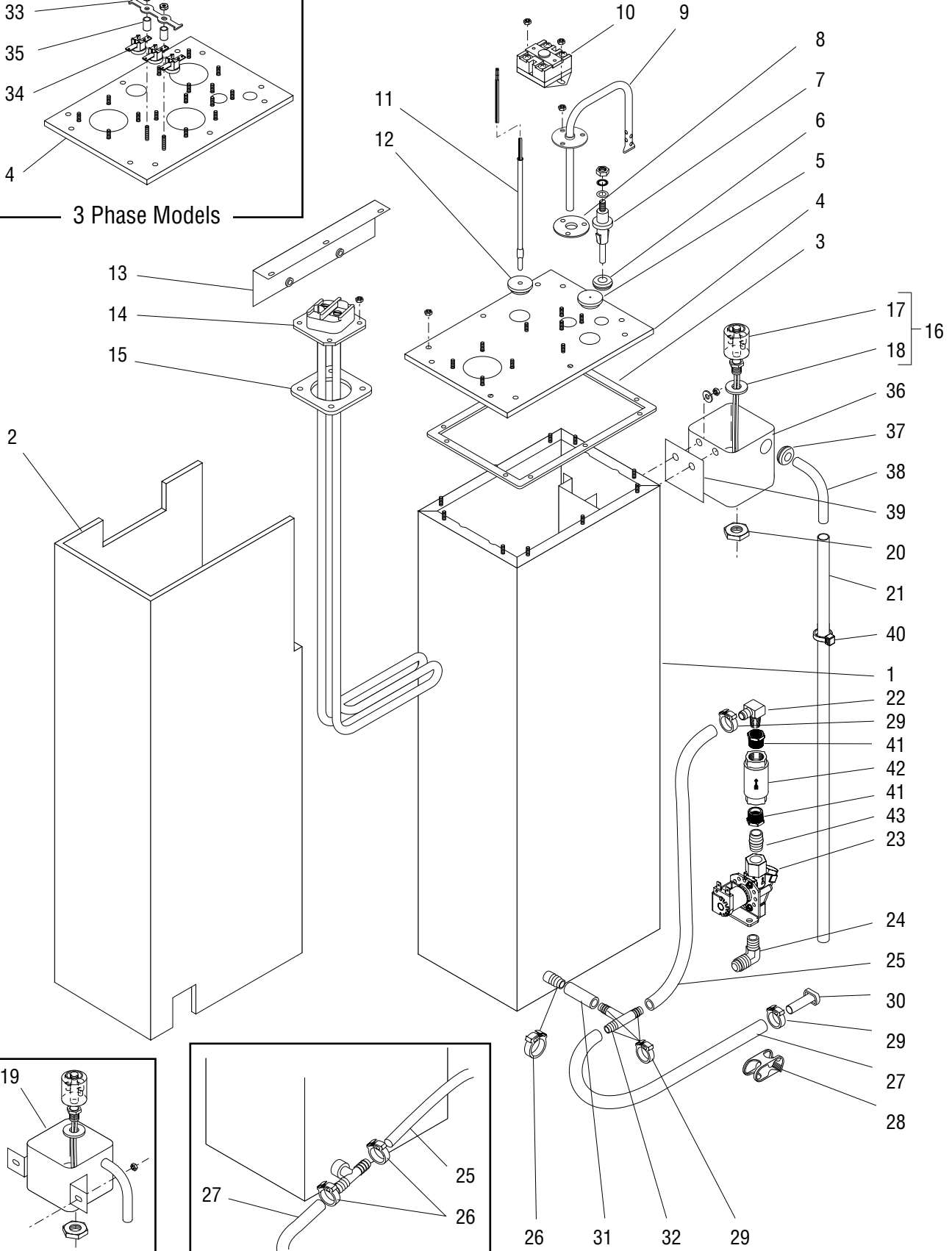

Early Models

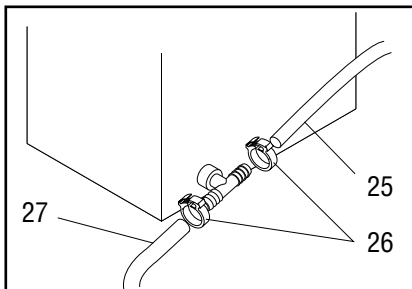

Early Models



## TANK ASSEMBLY

ITEM	PART NO.	QTY.	DESCRIPTION	
24	34768.0000	1	Elbow .38" NPT x .63" flare	
25	20976.0005*	1	Tube, Silicone .375" ID x 7.5" (Order item 44) (Early models)	
	20976.0055*	1	Tube, Silicone .375" ID x 9.0" (Order item 44)(Late models)	
26	12422.0005	1	Clamp .62/.71" ID (2 used on early models)	
27	20976.0068*	1	Tube, Silicone .375" ID x 19.0" (Order item 44)	
28	11630.0001	1	Clip, Shut-off	
29	12422.0001	5	Clamp .59/.66" ID (3 less used on early models)	
30	34392.0000	1	Plug, Hose	
31	20976.0072*	1	Tube, Silicone .375" ID x 1.5" (Order item 44)	} Late models only
32	38948.0001	1	Fitting, Tee .375" Barb	
33	38821.0000	1	Strap	} 3 Phase models only
	00973.0000	2	Nut, Keps #6-32	
34	29329.0003	3	Limit Thermostat	
35	39829.0000	2	Spacer	
36	41259.0002	1	Overflow Cup, Aluminum	} Late models only
	01522.0000	2	Washer	
	00910.0000	2	Nut, Hex #10-32	
37	02536.0000	1	Grommet	
38	34612.0000	1	Tube	
39	41266.0000	1	Film, Insulating	
40	36329.0002	1	Tie, Cable	
41	35851.0000	2	Fitting .375FPT x .500MPT	} Late models only
42	40831.0000	1	Check Valve	
43	36476.0000	1	Fitting, Close Nipple .375NPT	
44	20976.1000	-	Tube, Silicone .375" ID x 12.0" (Use as required)	} Not Illustrated
	20976.1001	-	Tube, Silicone .375" ID x 30.0" (Use as required)	

\* Indicates the part number listed is for reference only. See DESCRIPTION for possible service replacement.

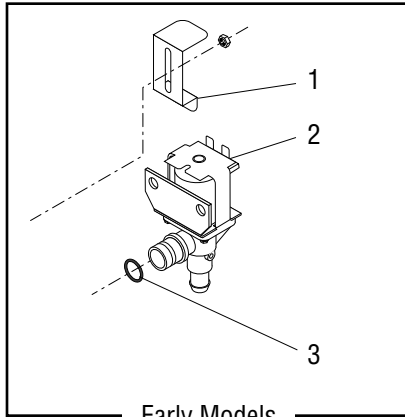

Early Models

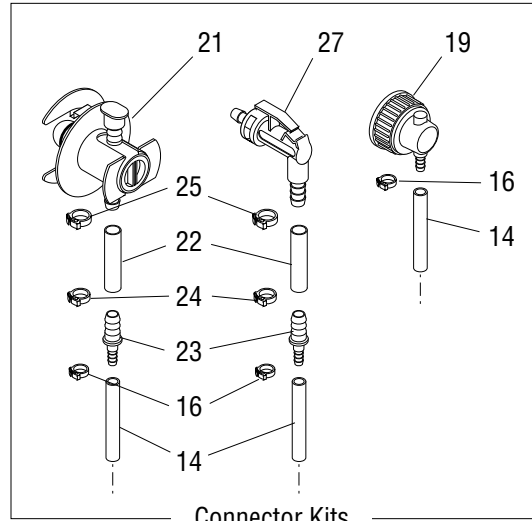

Connector Kits

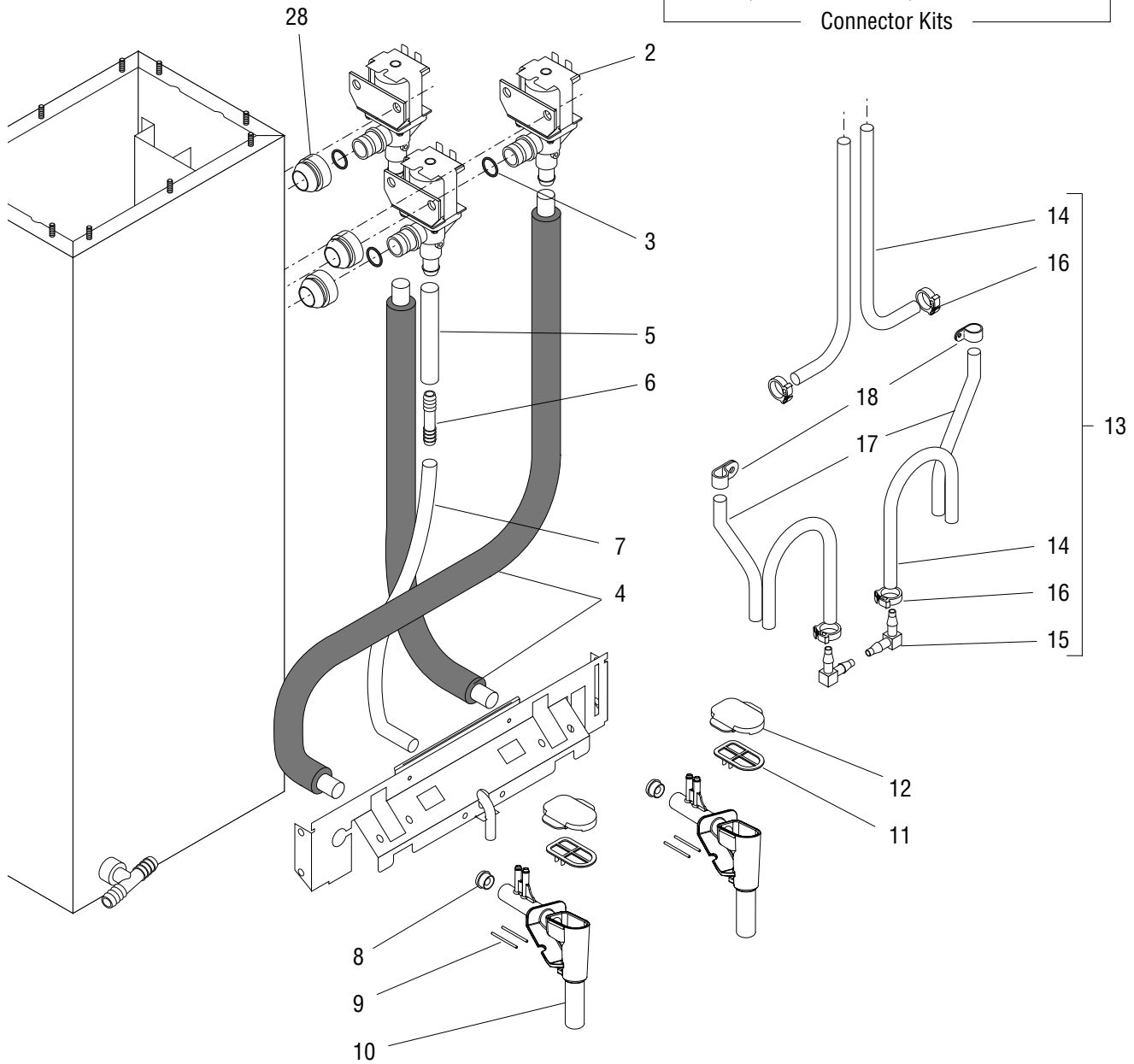

## DISPENSE VALVES & LINES

ITEM	PART NO.	QTY.	DESCRIPTION	
1	29576.0000	3	Bracket	
	00970.0000	3	Nut, Keps #8-32	
2	34202.0000	3	Valve, Dispense (Includes item 3)(Refer to item 41)	
3	24733.0011	3	O-ring	
4	34962.1000	2	Warmer Tube Assy (Includes Warmer Tape w/Leads)	
5	20976.0046*	1	Tube, Silicone .375" ID x 5.0" (Order item 36)	
6	34644.0000	1	Connector, Barb .375"	
7	28526.0002*	1	Tube, Silicone .313" ID x 16.0" (Order item 37)	
8	34807.0000	2	Flow Restrictor (Optional for 1.8 oz/sec. flow rate)	
9	34689.0000*	4	Pin	
10	34346.1000	2	Mixing Chamber Assy (Includes items 8, 9, 11 & 12)	
	01315.0000	4	Screw, Truss Head Sltd. #8-32 x .38"	
11	34198.0000*	2	Lid	
12	34384.0000*	2	Snap Cap	
13	34727.1000	2	Hose Assy .187" ID (Incl. items 14 - 16)	} Also order item 37
	34727.1001	2	Hose Assy .187" ID x 14.0" Feed End (Incl. items 14 - 16)	
	34728.1000	2	Hose Assy .125" ID (Incl. items 14 - 16)	
14	34729.0000*	4	Hose .187" ID x 9.0"	} Order item 13
	34729.0001*	2	Hose .187" ID x 14.0"	
	34728.0000*	4	Hose .125" ID x 9.0"	
15	34714.0000	2	Elbow (.187" ID Hose Assy)	
	34715.0000	2	Elbow (.125" ID Hose Assy)	
16	12422.0003	4	Clamp .40/.45" ID (.187" ID Hose Assy)	
	12422.0007	4	Clamp .31/.34" ID (.125" ID Hose Assy)	
17	34726.0001*	2	Tube, Norprene .125" I.D. x 6.0" (Order item 39)	
18	05920.0000	2	Clip	
19	35057.0000	2	Connector .187"	
	35057.0001	2	Connector .25"	
20	35055.1000	2	Adapter Kit (Includes items 21 - 25)	
21	33160.0000	2	Connector	
22	11707.0029*	2	Hose, Silicone .25" I.D. x 1.75" (Order item 40)	
23	35053.0000	2	Coupling, Reducing	
24	12422.0000	2	Clamp .47/.54" I.D.	
25	12422.0006	2	Clamp .53/.59" I.D.	
26	35056.1000	2	Adapter Kit (Includes items 22,23,24 & 27)	

(Continued)

\* Indicates the part number listed is for reference only. See DESCRIPTION for possible service replacement.

(Continued)

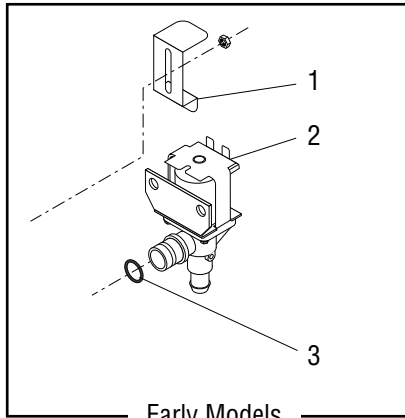

Early Models

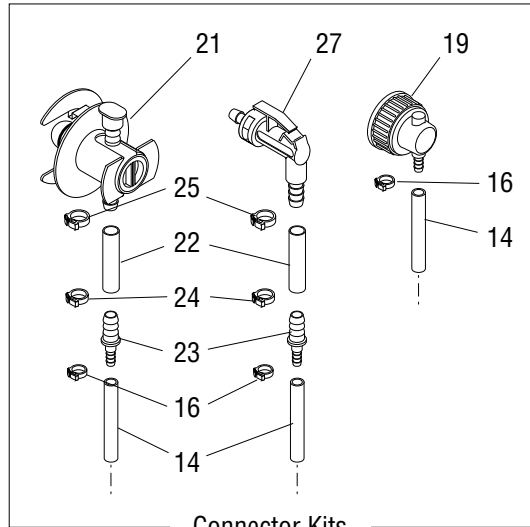

Connector Kits

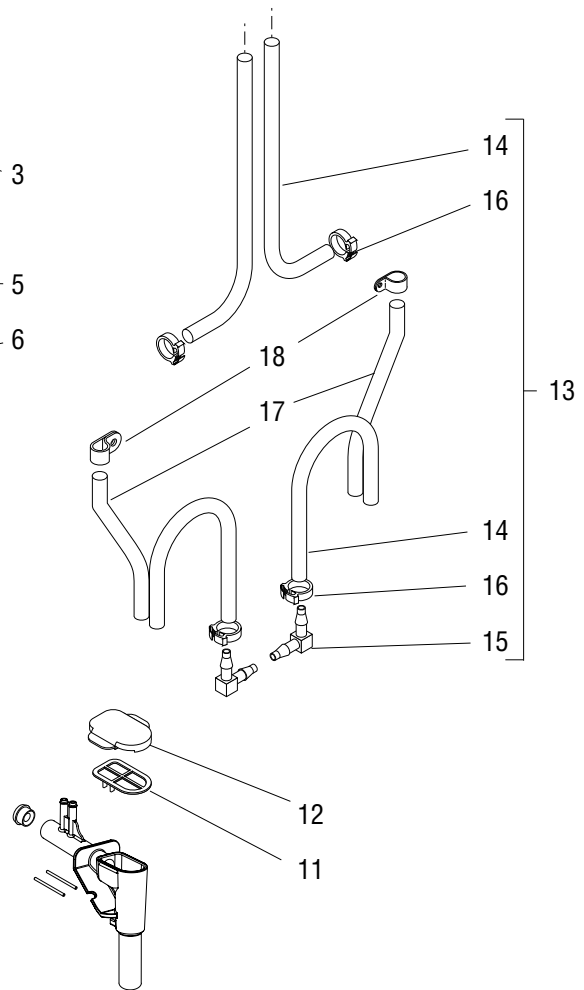
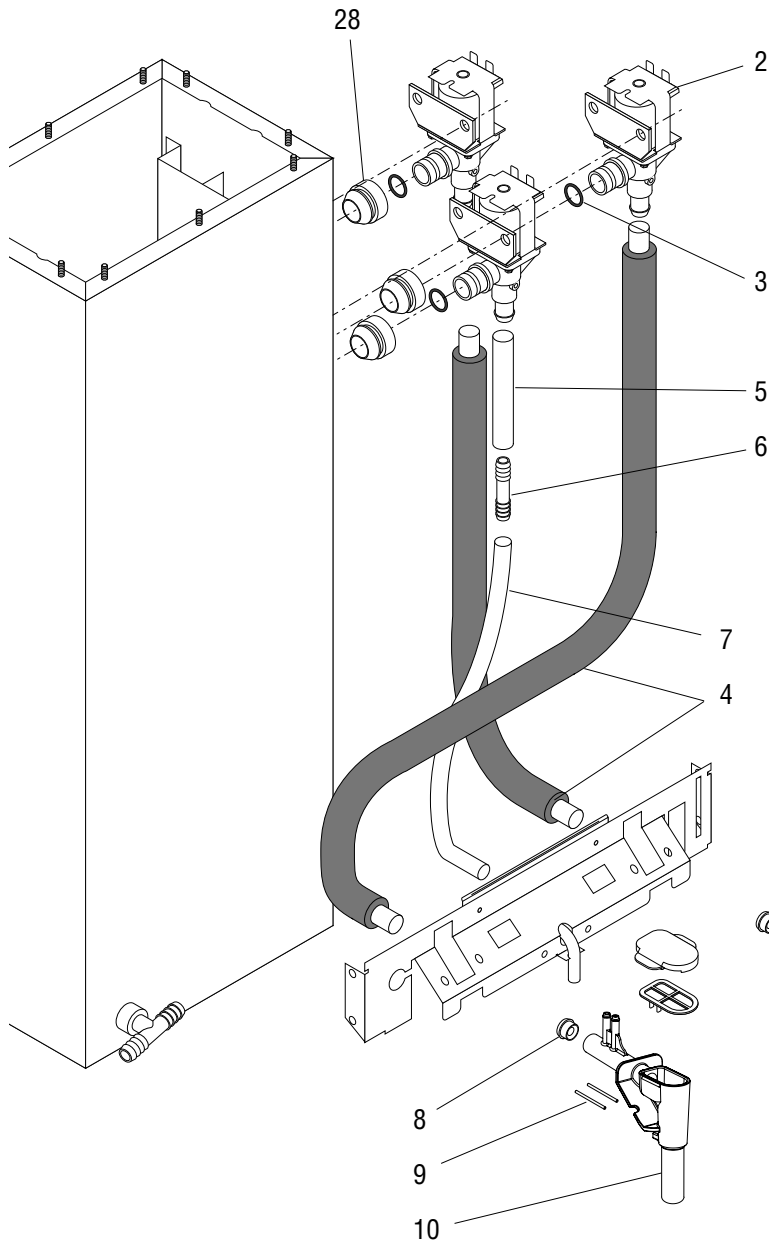

## DISPENSE VALVES & LINES

ITEM	PART NO.	QTY.	DESCRIPTION
27	35054.0000	2	Connector
28	37970.0000	3	Grommet, Valve Mounting (Late models only)
Items 29 through 41 are Not Illustrated			
29	34400.0200	-	Adapter Kit (Incl. items 13,16, 19 & 38)(Uses .125" I.D. Hose & Clamps)
30	34400.0201	-	Adapter Kit (Incl. items 13,16, 19 & 38)(Uses .188" I.D. Hose & Clamps)
31	34400.0202	-	Adapter Kit (Incl. items 13,16, 21 & 38)(Uses .125" I.D. Hose & Clamps)
32	34400.0203	-	Adapter Kit (Incl. items 13,16, 21 & 38)(Uses .188" I.D. Hose & Clamps)
33	34400.0204	-	Adapter Kit (Incl.items 13,16, 27 & 38)(Uses .125" I.D. Hose & Clamps)
34	34400.0205	-	Adapter Kit (Incl. items 13,16, 27 & 38)(Uses .188" I.D. Hose & Clamps)
35	34400.0208	-	Adapter Kit, 14.0" Feed End (Incl. items 13,16, 19 & 38)(Uses .188" I.D. Hose & Clamps)
36	33159.1000	-	Tube, Silicone .375" ID x 12.0" (Use as required)
	33159.1001	-	Tube, Silicone .375" ID x 36.0" (Use as required)
37	28526.1000	-	Tube, Silicone .313" ID x 12.0" (Use as required)
	28526.1001	-	Tube, Silicone .313" ID x 36.0" (Use as required)
	28526.1002	-	Tube, Silicone .313" ID x 60.0" (Use as required)
38	M2531.0001	-	Lube Compound .30 oz.
39	34726.1000	-	Tube, Norprene .125" I.D. x 10.0" (Use as required)
40	11707.1000	-	Tube, Silicone .25" ID x 12.0" (Use as required)
	11707.1001	-	Tube, Silicone .25" ID x 36.0" (Use as required)
	11707.1002	-	Tube, Silicone .25" ID x 120.0" (Use as required)
41	34202.0050	-	Repair Kit, Dispense Valve (Includes items for 1 Valve)

\* Indicates the part number listed is for reference only. See DESCRIPTION for possible service replacement.

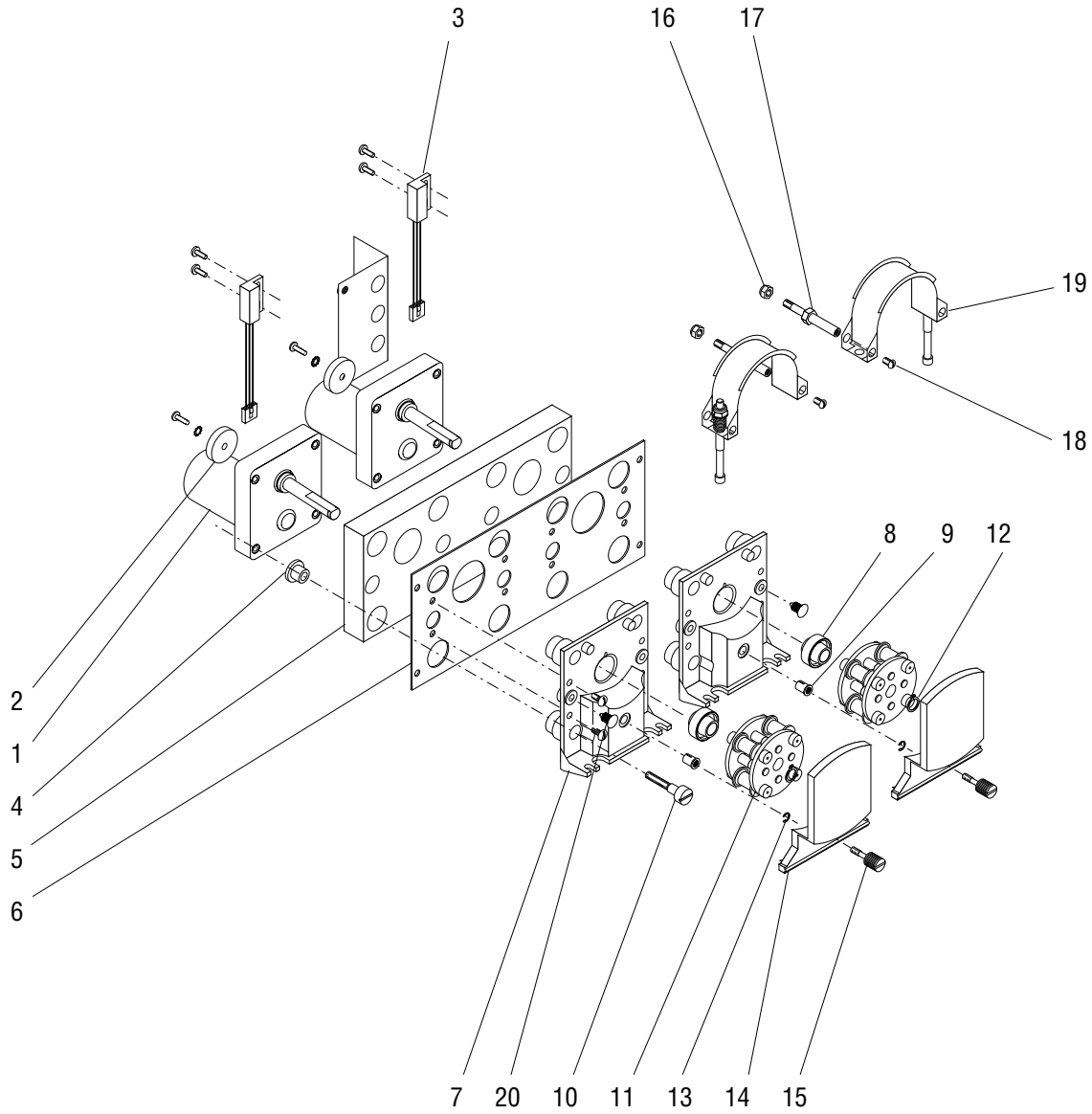

## PUMP ASSEMBLY

ITEM	PART NO.	QTY.	DESCRIPTION
-	34682.1000	1	Pump Assy. (Includes items 2 - 21)
1	34536.0001	2	Motor
2	32654.0000	2	Magnet Hub
	01512.0000	2	Lockwasher, Ext.-tooth #10
	01331.0004	2	Screw, Round Head Sltd. Locking #10-32 x .50"
3	33608.1000	2	RPM Sensor
	02336.0000	4	Screw, Truss Head Sltd. #4-40 x .38"
4	32957.0000	8	Bushing, Rubber
5	34748.0000	1	Insulation
6	34193.0000	1	Bracket, Pump Mounting
	01315.0005	4	Screw, Truss Head BLK #8-32 x .50"
7	34166.1002	2	Block Assy, Pump (Includes items 8 & 9)
	02328.0003	8	Screw, Pan Head Sltd. #6-32 x .312"
8	33825.0000	2	Bearing
9	32928.0000	2	Insert, Threaded #10-32
10	32927.0000	8	Shoulder Bolt #10-32
11	32706.1000	2	Rotor
12	32652.0000	2	Ring, Retaining
13	34998.0000	2	E-ring
14	34167.0000	2	Cover
15	34997.0000	2	Thumb Screw #10-32 x .625"
16	34765.0000	2	Nut, Flanged #10-32
17	32609.0000	2	Standoff
18	01311.0001	2	Screw, Truss Head Sltd. Locking #8-32 x .25"
19	40030.1000	2	Compression Band Assy.
20	36149.0000	2	Fastener, Snap in
21	00617.0000	1	Cable Tie

\* Indicates the part number listed is for reference only. See DESCRIPTION for possible service replacement.

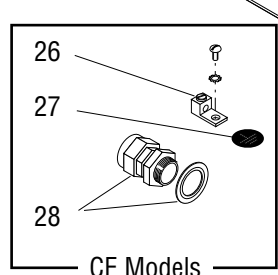
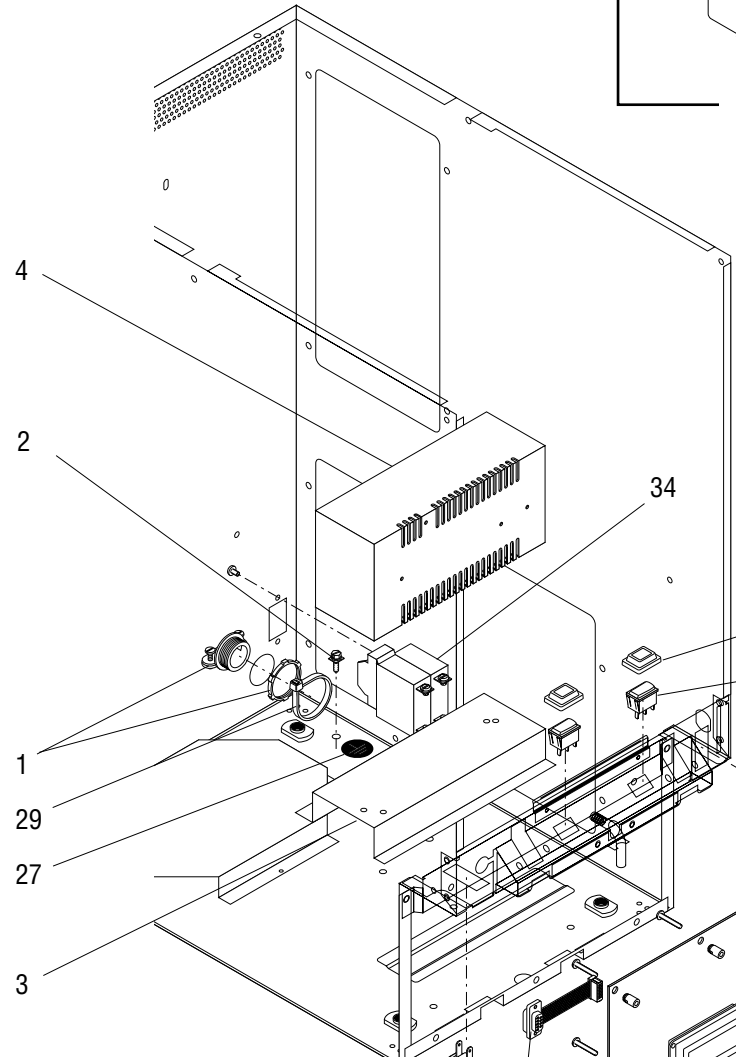
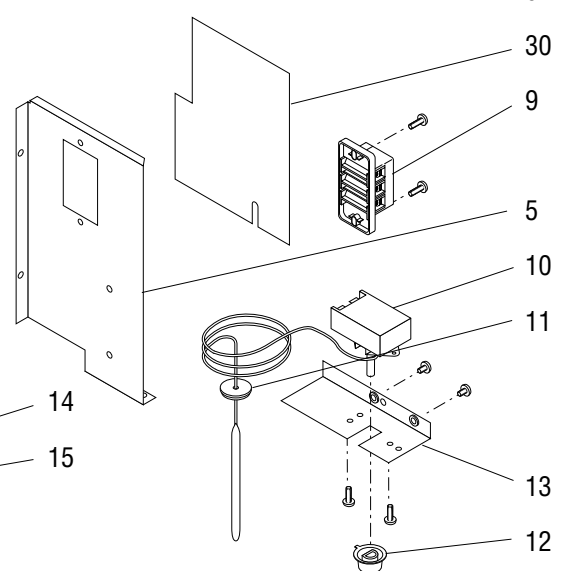
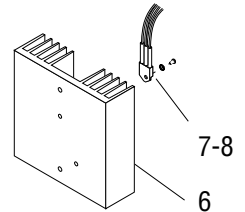
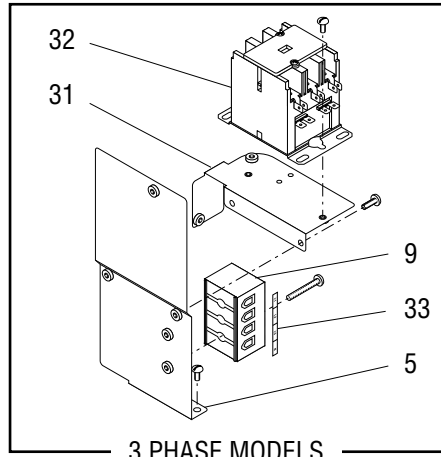



## ELECTRICAL CONTROLS

ITEM	PART NO.	QTY.	DESCRIPTION
1	01590.0000	1	Cable Connector
2	01309.0000	1	Screw, Grounding #10-32 x .50"
3	34345.0001	1	Bracket
	01311.0000	1	Screw, Truss Head Sltd. #8-32 x .25"
4	33363.0003	1	Power Supply
	32283.0000	3	Screw, M4 x 6mm
5	34164.0000	1	Bracket
	38814.0000	1	Bracket (3 Phase models only)
	01311.0003	2	Screw, Truss Head Sltd. Blk #8-32 x .25"
	01311.0000	1	Screw, Truss Head Sltd. SST #8-32 x .25"
6	20541.0001	1	Heat Sink
	01347.0000	2	Screw, Truss Head Serr. #6-32 x .38"
7	12565.0011	1	Triac, 40A
	12565.0020	1	Triac, 40A (3 Phase models only)
	01520.0000	1	Lockwasher, Split #6
	02328.0003	1	Screw, Pan Head Sltd. #6-32 x .312"
8	M2522.1000	-	Heat Sink Compound
9	07038.0000	1	Terminal Block, 3-Pole
	01106.0003	1	Terminal Block, 2-Pole (230V CE models)
	01317.0000	2	Screw, Truss Head Sltd. #8-32 x .50"
	21869.0000	1	Terminal Block, 4-Pole (3 Phase models only)
	38030.0000	2	Screw, Fil Head #8-32 x 1.25"
10	07045.0004	1	Thermostat (Includes items 11, 12 & 13)(Early Models)
	02301.0001	2	Screw, Pan Head Phillips #6-32 x .312"
11	07073.0001	1	Grommet, Thermostat (Early Models)
12	00720.0000	1	Knob (Early Models)
13	28224.0001	1	Bracket (Early Models)
	01311.0003	2	Screw, Truss Head Sltd. Blk #8-32 x .25"
14	34390.0000	2	Cap, Rocker Switch
15	27437.0001	2	Switch, Selector
16	34386.0000	1	Switch, Door Open
17	34197.1003	1	Circuit Board, Control
	38123.0000	8	Screw, Truss Head #6-32 x 1.00"
18	29081.0003	8	Spacer
19	38492.0000	1	Bracket
	34380.0000	1	Bracket (230V CE & 3 Phase models only)
	01311.0000	2	Screw, Truss Head Sltd. #8-32 x .25"

(Continued)

\* Indicates the part number listed is for reference only. See DESCRIPTION for possible service replacement.

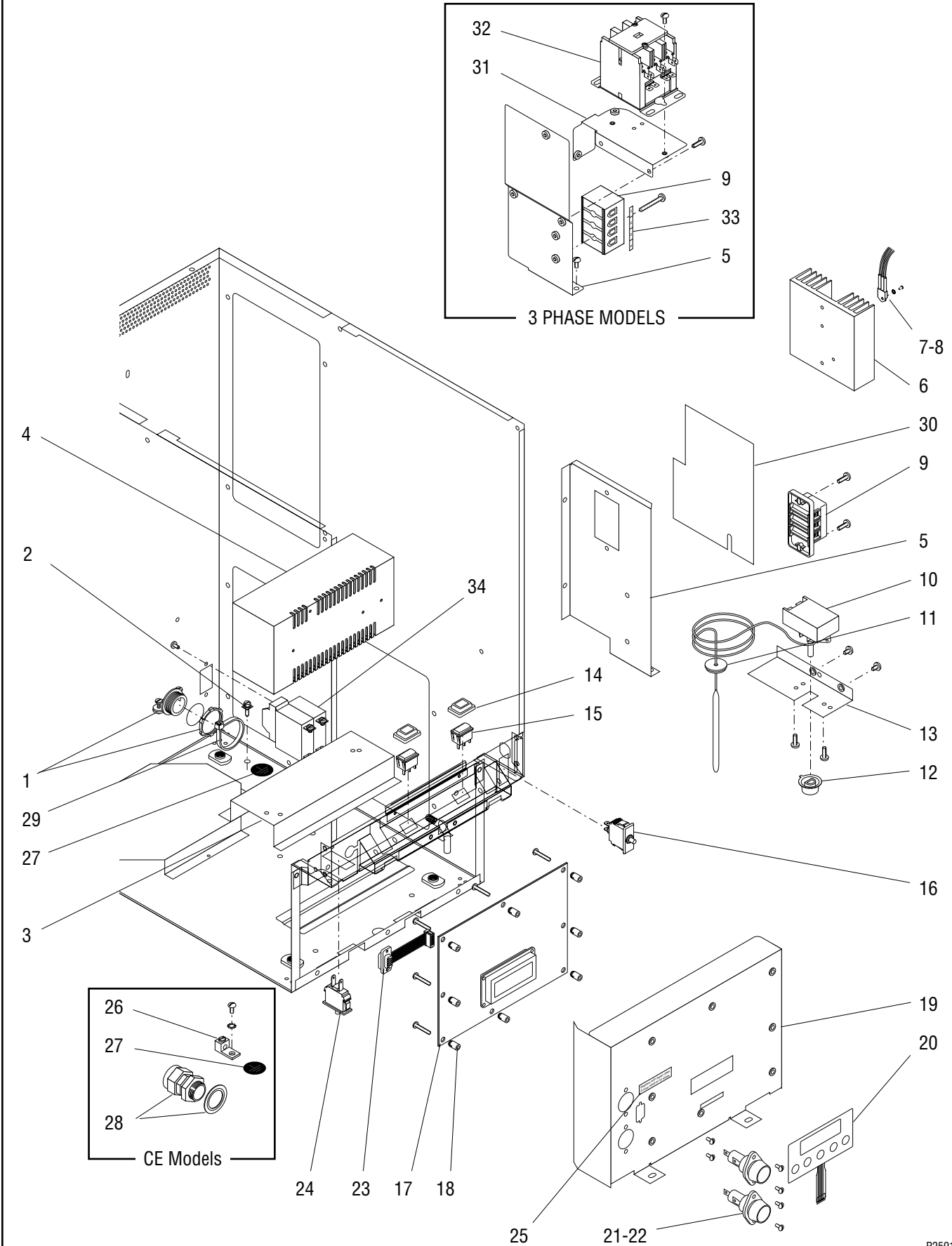

## ELECTRICAL CONTROLS

ITEM	PART NO.	QTY.	DESCRIPTION
20	34205.1000	1	Membrane Switch
21	21741.0000	2	Fuse Holder (230V CE & 3 Phase models only)
	02328.0003	4	Screw, Pan Head Sltd. #6-32 x .312"
22	22012.0000	2	Fuse, 10A (230V CE & 3 Phase models only)
23	34393.0000	1	Cable, Ribbon
	02327.0002	2	Screw, Pan Head Sltd. Locking #4-40 x .312"
24	34386.0000	1	Switch, Dispense Volume Memory
25	27443.0001	1	Decal, Fuse Rating (230V CE & 3 Phase models only)
26	27705.0000	1	Terminal Lug (230V CE & 3 Phase models only)
	01375.0000	1	Screw, Pan Head Brass #10-32 x .50"
	01512.0000	1	Lockwasher, Ext.-tooth #10
27	00824.0002	1	Decal, Ground
28	32833.0000	1	Strain Relief, Cord (230V CE & 3 Phase models only)
	01531.0000	1	Washer, Reducing
29	36329.0002	1	Cable Tie, Power Cord Retainer
30	00637.0007	1	Shield. Terminal Block
31	38817.0000	1	Bracket, Contactor Mounting (3 Phase models only)
	01311.0000	2	Screw, Truss Head Sltd. #8-32 x .25"
32	38045.0000	1	Contactor, 3-Pole 208/240V (3 Phase models only)
	01311.0000	2	Screw, Truss Head Sltd. #8-32 x .25"
33	34588.0001	1	Decal, Terminal Block (3 Phase models only)
34	38894.0001	1	Switch, Master ON/OFF (Late Models)
	01308.0003	2	Screw, truss Head, Locking BLK #6-32 x .25"
	01327.0000	4	Screw, Pan Head #10-32 x .38" } Terminals
	01512.0000	4	Lockwasher #10 }

The following items are not illustrated

35	20630.0005	1	Power Cord (LCR-2 Models only)
	23799.0001	1	Power Cord (LCR-2C Models only)
	42749.0112	1	Power Cord (LCR-2A Models only)
36	34534.0000	1	Harness, Main Wiring (Early models)
	36798.0000	1	Harness, Main Wiring (Late models)
	34534.0001	1	Harness, Main Wiring (230V CE models)(Early models)
	36798.0001	1	Harness, Main Wiring (230V CE models)(Late models)
	36798.0002	1	Harness, Main Wiring (3 Phase models only)
37	34535.0000	1	Harness, Switches/Power (Early models)
	38570.0001	1	Harness, Switches/Power (Late models)
38	34519.0000	1	Harness, Portion Control Wiring (Early models)
39	34523.0000	1	Harness, Motors Wiring

(Continued)

\* Indicates the part number listed is for reference only. See DESCRIPTION for possible service replacement.

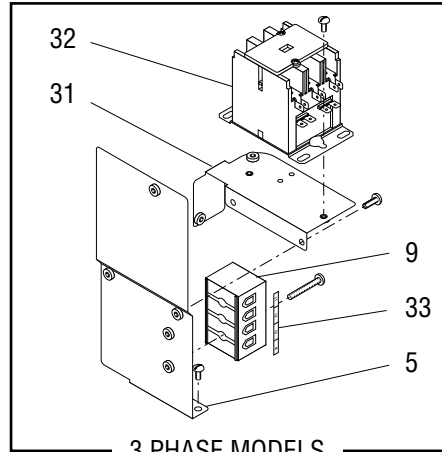

3 PHASE MODELS

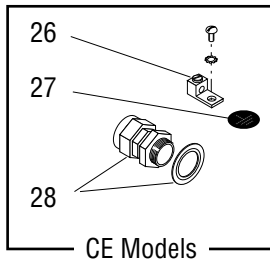
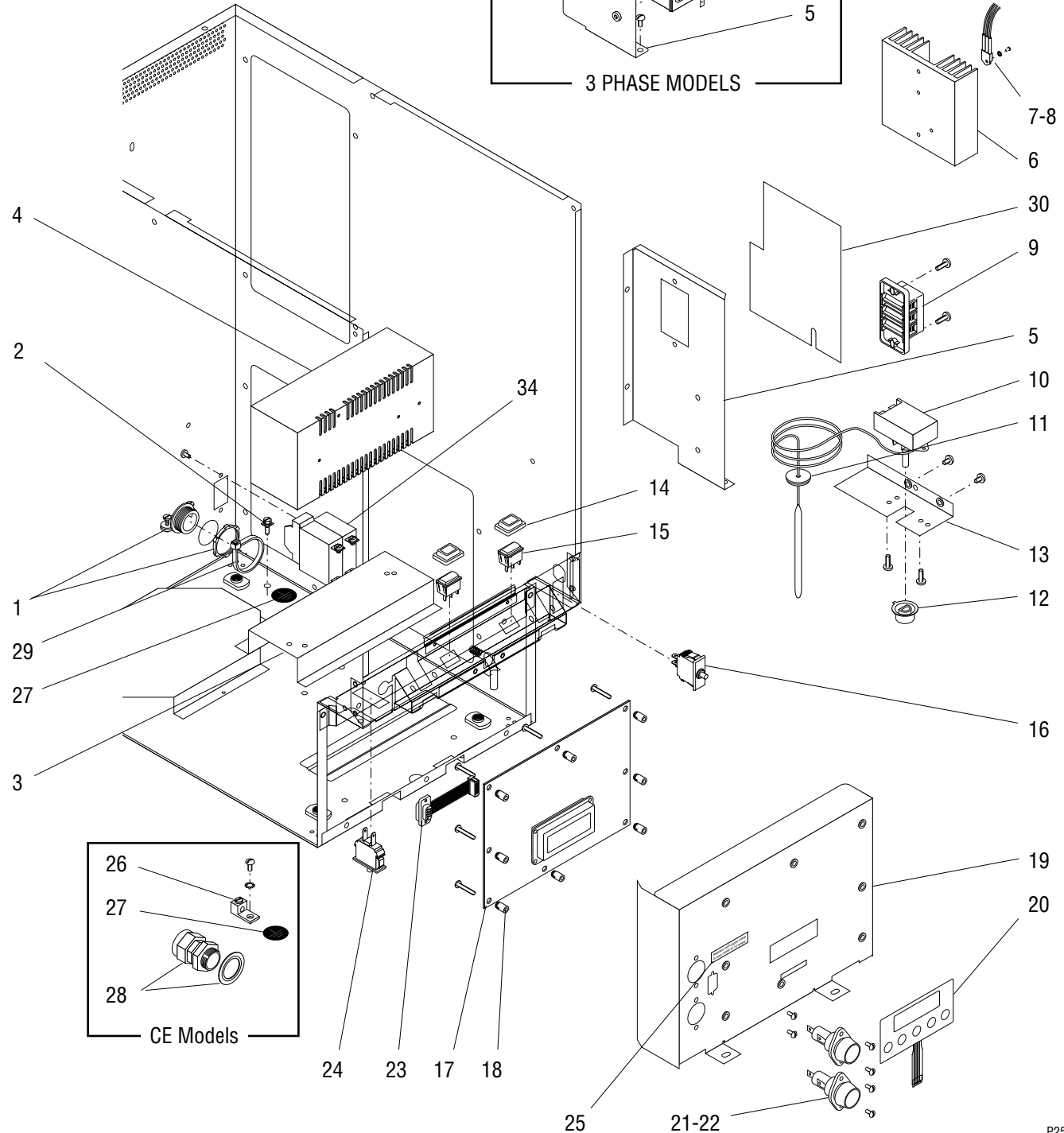
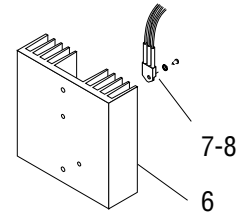

CE Models

## ELECTRICAL CONTROLS

ITEM	PART NO.	QTY.	DESCRIPTION
40	34525.0000	1	Harness, T-block to Tank Heater & Limit
	34525.0001	1	Harness, T-block to Tank Heater & Limit (Master ON/OFF Switch)
41	34526.0000	1	Harness, Probe Wiring (Early models)
42	36045.0000*	1	Harness, Refrigeration (Early models)
43	34961.0000	1	Harness, Tube Warmer Wiring (Early models)
44	21014.0196	1	Lead, Thermostat Blk 30.0" (Early Models)
45	35081.0000	1	Wire, Double Limit Jumper (230V CE models)
46	36049.0000	1	Jumper - Compressor Module
	36049.0007	1	Jumper - Compressor Module (High Flow)
47	36049.0003	1	Jumper, Circuit Board (Models with Pull and Hold Controls)
	36049.0007	1	Jumper, Circuit Board (Models with Pull and Hold Controls) (High Flow)
	36049.0001	1	Jumper, Circuit Board (Models with Portion Controls)
	36049.0008	1	Jumper, Circuit Board (Models with Portion Controls)(High Flow)
	36049.0006	1	Jumper, Circuit Board (3 Phase models with Portion Controls)
48	37518.0001	1	Harness, Door Wiring (Late models)
49	21012.0133	3	Lead, Electric 12AWG Blue 6.0"
50	39621.0000	1	Wiring Harness, Contactor to Tank Heater
51	39621.0001	1	Wiring Harness, Terminal block to Contactor
52	39621.0002	1	Wiring Harness, Protection
53	39630.0000	1	Capacitor Assy, W/Leads (3 Phase Models)
54	38920.0000	1	Wiring Harness, Master ON/OFF Switch to Terminal Block
55	34808.0002	1	Capacitor, EMI Filter (3 Phase Models)

\* Indicates the part number listed is for reference only. See DESCRIPTION for possible service replacement.

## NUMERICAL INDEX

PART NO.	PAGE NO.	PART NO.	PAGE NO.	PART NO.	PAGE NO.	PART NO.	PAGE NO.
00467.0000.....	19	05515.0000.....	23	27442.0000.....	7	34202.0050.....	29
00606.0000.....	17	05920.0000.....	27	27443.0001.....	35	34205.1000.....	35
00617.0000.....	17,31	07038.0000.....	33	27705.0000.....	35	34283.0002.....	9,13
00637.0007.....	35	07045.0004.....	33	28095.0000.....	5	34284.1011.....	9
00656.0001.....	5	07073.0001.....	23,33	28181.0003.....	7	34284.1012.....	9
00720.0000.....	33	11630.0001.....	25	28224.0001.....	33	34334.0000.....	9
00824.0002.....	35	11646.0002.....	5	28526.0002.....	27	34335.0002.....	5
00901.0000.....	17	11707.0029.....	27	28526.0020.....	5	34340.0000.....	11,13
00906.0000.....	23	11707.0040.....	5	28526.1000.....	7,29	34340.1000.....	9,13
00908.0000.....	23	11707.1000.....	7,29	28526.1001.....	7,29	34341.1000.....	9,13
00910.0000.....	25	11707.1001.....	7,29	28526.1002.....	7,29	34345.0001.....	33
00946.0000.....	23	11707.1002.....	7,29	29081.0003.....	33	34346.1000.....	27
00970.0000.....	23,27	12322.1000.....	23	29329.0003.....	25	34361.0000.....	9
00971.0000.....	23	12377.0000.....	23	29504.0004.....	9,13	34362.0000.....	9,13
00973.0000.....	25	12398.0002.....	23	29576.0000.....	27	34362.0001.....	9
00986.0002.....	5	12422.0000.....	5,27	29710.0014.....	7	34366.0000.....	5
01106.0003.....	33	12422.0001.....	5,25	32283.0000.....	33	34379.0002.....	5
01219.0000.....	9,13	12422.0003.....	27	32609.0000.....	31	34380.0000.....	33
01308.0003.....	7,35	12422.0005.....	25	32652.0000.....	31	34384.0000.....	27
01309.0000.....	33	12422.0006.....	27	32654.0000.....	31	34385.0001.....	5
01311.0000.....	9,11,13	12422.0007.....	27	32656.0000.....	5	34385.0003.....	5
01311.0000.....	17,33,35	12565.0011.....	33	32706.1000.....	31	34386.0000.....	33,35
01311.0001.....	31	12565.0020.....	33	32833.0000.....	35	34387.0000.....	9,13
01311.0003.....	5,7	12570.0000.....	23	32927.0000.....	31	34390.0000.....	33
01315.0000.....	27	20203.0100.....	23	32928.0000.....	31	34392.0000.....	25
01315.0005.....	5,7,23,31	20541.0001.....	33	32957.0000.....	31	34393.0000.....	35
01317.0000.....	33	20630.0005.....	35	33039.0001.....	9,13	34400.0200.....	29
01322.0001.....	9,13	20936.1000.....	23	33159.1000.....	29	34400.0201.....	29
01326.0000.....	23	20976.0005.....	25	33159.1001.....	29	34400.0202.....	29
01326.0008.....	17	20976.0046.....	27	33160.0000.....	27	34400.0203.....	29
01327.0000.....	17,35	20976.0055.....	25	33297.0002.....	17	34400.0204.....	29
01331.0004.....	31	20976.0067.....	23	33363.0003.....	33	34400.0205.....	29
01347.0000.....	33	20976.0068.....	25	33418.0001.....	23	34400.0208.....	29
01375.0000.....	35	20976.0072.....	25	33434.1000.....	9,13	34472.1000.....	5
01382.0000.....	5,9,13,17	20976.1000.....	25	33434.1002.....	9,13	34473.0000.....	9
01384.0000.....	17	20976.1001.....	25	33461.0008.....	7	34519.0000.....	35
01501.0000.....	23	21012.0133.....	37	33608.1000.....	31	34523.0000.....	35
01512.0000.....	31,35	21014.0196.....	37	33825.0000.....	31	34525.0000.....	37
01520.0000.....	33	21431.0003.....	17	33926.1001.....	23	34525.0001.....	37
01522.0000.....	25	21741.0000.....	35	34150.0000.....	9	34526.0000.....	37
01526.0001.....	5	21869.0000.....	33	34152.0003.....	5	34527.0000.....	9
01531.0000.....	35	22012.0000.....	35	34158.1002.....	23	34531.1000.....	9
01590.0000.....	33	22462.0007.....	17	34160.0000.....	23	34534.0000.....	35
02301.0001.....	33	22462.0015.....	17	34160.0001.....	23	34534.0001.....	35
02327.0002.....	35	22462.0016.....	17	34164.0000.....	33	34535.0000.....	35
02328.0003.....	33,35	22462.1000.....	17	34166.1002.....	31	34536.0001.....	31
02335.0001.....	17	22728.0002.....	23	34167.0000.....	31	34588.0001.....	35
02336.0000.....	31	23717.0003.....	23	34186.1006.....	5	34612.0000.....	25
02370.0003.....	17	23799.0001.....	35	34190.0000.....	7	34644.0000.....	27
02536.0000.....	5,23,25	24733.0011.....	27	34193.0000.....	31	34666.0001.....	15
02547.0000.....	13	26444.0000.....	9	34194.1001.....	7	34667.0000.....	9
03633.0000.....	23	26528.0000.....	5	34197.1003.....	33	34667.0001.....	13
03803.0002.....	23	26622.0002.....	23	34198.0000.....	27	34682.1000.....	31
03807.0000.....	23	27437.0001.....	33	34202.0000.....	27	34684.0000.....	23

## NUMERICAL INDEX

PART NO.	PAGE NO.	PART NO.	PAGE NO.	PART NO.	PAGE NO.	PART NO.	PAGE NO.
34689.0000.....	27	35830.0000.....	17	38030.0000.....	33		
34702.0000.....	15	35833.0000.....	7	38045.0000.....	35		
34708.0000.....	9,13	35834.0000.....	17	38123.0000.....	33		
34709.0000.....	11,13	35836.0000.....	17	38301.0001.....	17		
34710.0000.....	11,13	35838.0000.....	17	38433.0000.....	5		
34711.0000.....	9,13	35851.0000.....	25	38492.0000.....	33		
34712.0000.....	9,13	35883.0003.....	7	38570.0001.....	35		
34713.0000.....	31	35884.1003.....	7	38735.1000.....	9,13		
34714.0000.....	27	35887.0000.....	17	38814.0000.....	33		
34715.0000.....	27	35888.0000.....	17	38817.0000.....	35		
34726.0001.....	29	35890.0001.....	7	38818.1000.....	23		
34726.1000.....	29	35891.0000.....	17	38820.0000.....	7		
34727.1000.....	27	35959.0000.....	15	38821.0000.....	25		
34727.1001.....	27	35961.0000.....	21	38894.0001.....	35		
34728.0000.....	27	35962.0000.....	21	38920.0000.....	37		
34728.1000.....	27	35963.0000.....	21	38948.0001.....	25		
34729.0000.....	27	35965.0000.....	17	39621.0000.....	37		
34729.0001.....	27	36010.0000.....	19	39621.0001.....	37		
34742.0000.....	9,13	36011.0000.....	7	39621.0002.....	37		
34748.0000.....	31	36012.0000.....	11	39630.0000.....	37		
34765.0000.....	31	36016.0000.....	17	39762.0000.....	5		
34768.0000.....	25	36019.0001.....	19	39829.0000.....	25		
34783.0000.....	5	36021.0001.....	19	39999.1000.....	5		
34803.1000.....	17	36025.0001.....	7	40030.1000.....	31		
34807.0000.....	27	36025.0002.....	7	40054.0003.....	7		
34808.0002.....	37	36025.0004.....	7	40087.0000.....	13		
34809.0001.....	9,13	36037.0000.....	17	40091.0000.....	13		
34821.1000.....	5	36045.0000.....	37	40092.0000.....	13		
34893.0001.....	7	36049.0001.....	37	40094.0000.....	13		
34895.0000.....	23	36049.0003.....	37	40095.0000.....	13		
34960.0000.....	5	36049.0006.....	37	40831.0000.....	25		
34960.0001.....	5	36049.0007.....	37	41179.1000.....	23		
34961.0000.....	37	36049.0008.....	37	41259.0002.....	25		
34962.1000.....	27	36050.0001.....	17	41266.0000.....	25		
34997.0000.....	31	36056.0000.....	17	41512.0000.....	13		
34998.0000.....	31	36077.0001.....	17	41925.0011.....	13		
35053.0000.....	27	36113.1001.....	15	41925.1012.....	13		
35054.0000.....	29	36117.0000.....	17	42276.0000.....	5		
35055.1000.....	27	36118.0000.....	17	42749.0112.....	35		
35056.1000.....	27	36149.0000.....	7,15,31	44224.0000.....	9,13		
35057.0000.....	27	36308.0001.....	19	48817.0000.....	15		
35057.0001.....	27	36329.0002.....	25,35	M2336.1000.....	19		
35081.0000.....	37	36476.0000.....	25	M2522.1000.....	33		
35087.0000.....	11	36554.0000.....	11,13	M2531.0001.....	29		
35188.0000.....	5	36673.0000.....	11,13				
35581.0001.....	19	36785.0000.....	11,13				
35820.0000.....	19	36786.0000.....	11,13				
35821.0001.....	17	36798.0000.....	35				
35822.0000.....	21	36798.0001.....	35				
35822.0001.....	21	36798.0002.....	35				
35823.0001.....	17	37518.0001.....	37				
35825.0001.....	5	37850.0000.....	5				
35827.0000.....	17	37881.0000.....	7				
35829.0001.....	7	37970.0000.....	29				