

# BUNN®

## *OT & RT*

*(S/N RT00005364 & up)*

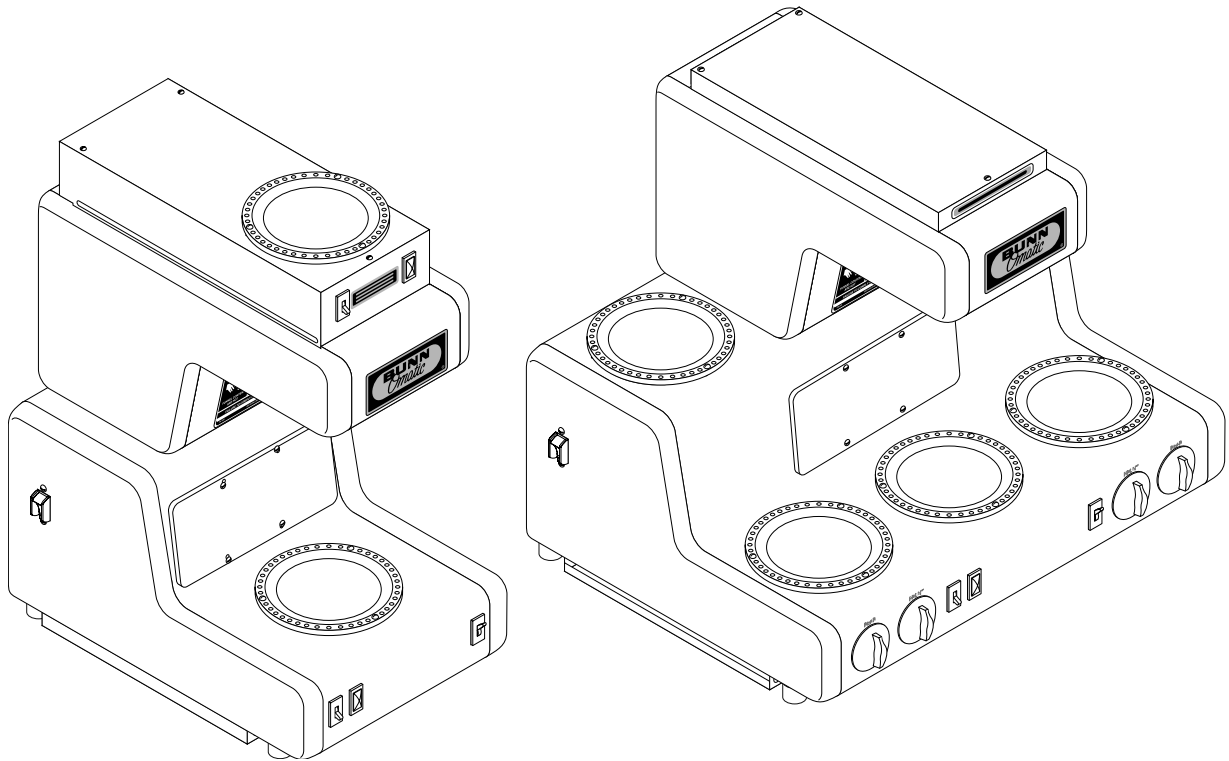

## INSTALLATION & OPERATING GUIDE

### BUNN-O-MATIC CORPORATION

POST OFFICE BOX 3227

SPRINGFIELD, ILLINOIS 62708-3227

PHONE: (217) 529-6601 FAX: (217) 529-6644

To ensure you have the latest revision of the Operating Manual, or to view the Illustrated Parts Catalog, Programming Manual, or Service Manual, please visit the Bunn-O-Matic website, at [www.bunn.com](http://www.bunn.com). This is absolutely FREE, and the quickest way to obtain the latest catalog and manual updates. For Technical Service, contact Bunn-O-Matic Corporation at 1-800-286-6070.



## **BUNN-O-MATIC COMMERCIAL PRODUCT WARRANTY**

Bunn-O-Matic Corp. ("BUNN") warrants equipment manufactured by it as follows:

- 1) Airpots, thermal carafes, decanters, GPR servers, iced tea/coffee dispensers, MCP/MCA pod brewers thermal servers and ThermoFresh servers (mechanical and digital)- 1 year parts and 1 year labor.
- 2) All other equipment - 2 years parts and 1 year labor plus added warranties as specified below:
  - a) Electronic circuit and/or control boards - parts and labor for 3 years.
  - b) Compressors on refrigeration equipment - 5 years parts and 1 year labor.
  - c) Grinding burrs on coffee grinding equipment to grind coffee to meet original factory screen sieve analysis - parts and labor for 4 years or 40,000 pounds of coffee, whichever comes first.

These warranty periods run from the date of installation BUNN warrants that the equipment manufactured by it will be commercially free of defects in material and workmanship existing at the time of manufacture and appearing within the applicable warranty period. This warranty does not apply to any equipment, component or part that was not manufactured by BUNN or that, in BUNN's judgment, has been affected by misuse, neglect, alteration, improper installation or operation, improper maintenance or repair, non periodic cleaning and descaling, equipment failures related to poor water quality, damage or casualty. In addition, the warranty does not apply to replacement of items subject to normal use including but not limited to user replaceable parts such as seals and gaskets. This warranty is conditioned on the Buyer 1) giving BUNN prompt notice of any claim to be made under this warranty by telephone at (217) 529-6601 or by writing to Post Office Box 3227, Springfield, Illinois 62708-3227; 2) if requested by BUNN, shipping the defective equipment prepaid to an authorized BUNN service location; and 3) receiving prior authorization from BUNN that the defective equipment is under warranty.

**THE FOREGOING WARRANTY IS EXCLUSIVE AND IS IN LIEU OF ANY OTHER WARRANTY, WRITTEN OR ORAL, EXPRESS OR IMPLIED, INCLUDING, BUT NOT LIMITED TO, ANY IMPLIED WARRANTY OF EITHER MERCHANTABILITY OR FITNESS FOR A PARTICULAR PURPOSE.** The agents, dealers or employees of BUNN are not authorized to make modifications to this warranty or to make additional warranties that are binding on BUNN. Accordingly, statements by such individuals, whether oral or written, do not constitute warranties and should not be relied upon.

If BUNN determines in its sole discretion that the equipment does not conform to the warranty, BUNN, at its exclusive option while the equipment is under warranty, shall either 1) provide at no charge replacement parts and/or labor (during the applicable parts and labor warranty periods specified above) to repair the defective components, provided that this repair is done by a BUNN Authorized Service Representative; or 2) shall replace the equipment or refund the purchase price for the equipment.

**THE BUYER'S REMEDY AGAINST BUNN FOR THE BREACH OF ANY OBLIGATION ARISING OUT OF THE SALE OF THIS EQUIPMENT, WHETHER DERIVED FROM WARRANTY OR OTHERWISE, SHALL BE LIMITED, AT BUNN'S SOLE OPTION AS SPECIFIED HEREIN, TO REPAIR, REPLACEMENT OR REFUND.**

In no event shall BUNN be liable for any other damage or loss, including, but not limited to, lost profits, lost sales, loss of use of equipment, claims of Buyer's customers, cost of capital, cost of down time, cost of substitute equipment, facilities or services, or any other special, incidental or consequential damages.

392, AutoPOD, AXIOM, BrewLOGIC, BrewMETER, Brew Better Not Bitter, BrewWISE, BrewWIZARD, BUNN Espresso, BUNN Family Gourmet, BUNN Gourmet, BUNN Pour-O-Matic, BUNN, BUNN with the stylized red line, BUNNlink, Bunn-OMatic, Bunn-O-Matic, BUNNserve, BUNNSERVE with the stylized wrench design, Cool Froth, DBC, Dr. Brew stylized Dr. design, Dual, Easy Pour, EasyClear, EasyGard, FlavorGard, Gourmet Ice, Gourmet Juice, High Intensity, iMIX, Infusion Series, Intellisteam, My Café, Phase Brew, PowerLogic, Quality Beverage Equipment Worldwide, Respect Earth, Respect Earth with the stylized leaf and coffee cherry design, Safety-Fresh, savemycoffee.com, Scale-Pro, Silver Series, Single, Smart Funnel, Smart Hopper, SmartWAVE, Soft Heat, SplashGard, The Mark of Quality in Beverage Equipment Worldwide, ThermoFresh, Titan, trifecta, Velocity Brew, A Partner You Can Count On, Air Brew, Air Infusion, Beverage Bar Creator, Beverage Profit Calculator, Brew better, not bitter., BUNNSource, Coffee At Its Best, Cyclonic Heating System, Daypart, Digital Brewer Control, Nothing Brews Like a BUNN, Pouring Profits, Signature Series, Tea At Its Best, The Horizontal Red Line, Ultra are either trademarks or registered trademarks of Bunn-O-Matic Corporation.

# CONTENTS

- Introduction .....2
- User Notices .....3
- Electrical Requirements .....4
- Plumbing Requirements .....4
- Initial Set-Up .....5
- Adjusting Brew Volumes .....6
- Operating Controls .....6
- Coffee Brewing .....7
- Cleaning .....7
- Troubleshooting .....8
- Service .....12
- Wiring Diagrams .....28

## INTRODUCTION

This equipment will brew a half-gallon batch of coffee into an awaiting decanter at the press of a button. The OT has two and the RT has five warmers to keep the beverage at the right temperature, on the RT one of which is capable of heating water to boiling. The brewer is only for indoor use on a sturdy counter or shelf.

## USER NOTICES

Carefully read and follow all notices on the equipment and in this manual. They were written for your protection. All notices on the equipment should be kept in good condition. Replace any unreadable or damaged labels.

**⚠ WARNING**

- ◆ **Fill water tank before turning - on - thermostat or connecting appliance to power source.**
- ◆ **Use only on a properly protected circuit capable of the rated load.**
- ◆ **Electrically ground the chassis.**
- ◆ **Follow national/local electrical codes.**
- ◆ **Do not use near combustibles.**

FAILURE TO COMPLY RISKS EQUIPMENT DAMAGE, FIRE, OR SHOCK HAZARD

READ THE ENTIRE OPERATING MANUAL BEFORE BUYING OR USING THIS PRODUCT

THIS APPLIANCE IS HEATED WHENEVER CONNECTED TO A POWER SOURCE  
00831.0000F 3/98 ©1998 BUNN-O-MATIC CORPORATION

00831.0000

**As directed in the International Plumbing Code of the International Code Council and the Food Code Manual of the Food and Drug Administration (FDA), this equipment must be installed with adequate backflow prevention to comply with federal, state and local codes. For models installed outside the U.S.A., you must comply with the applicable Plumbing /Sanitation Code for your area.**

00656.0001

**⚠ WARNING**



**FUNNEL CONTENTS ARE HOT**

**DISCARD DECANTER IF:**

- CRACKED
- SCRATCHED
- BOILED DRY
- HEATED WHEN EMPTY
- USED ON HIGH FLAME OR EXPOSED ELECTRIC ELEMENTS

**READ THE ENTIRE OPERATING MANUAL BEFORE USING THIS PRODUCT  
FAILURE TO COMPLY RISKS INJURY**

PN: 00658.0000G 02/08 © 1985 BUNN-O-MATIC CORPORATION

00658.0000

**⚠ WARNING**

**To reduce the risk of electric shock, do not remove or open cover. No user-serviceable parts inside. Authorized service personnel only. Disconnect power before servicing.**

37881.0000

## ELECTRICAL REQUIREMENTS

**CAUTION** - Do not connect the brewer to the power source until specified in Initial Set-Up.

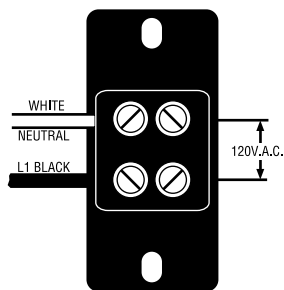

**MODELS OT15 & 20** require 2-wire, grounded service rated 120 volts ac, 15 or 20 amp respectively, single phase, 60 Hz. Model 15 has an attached cordset.

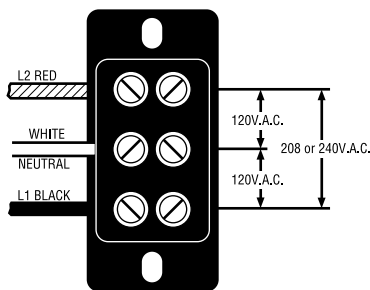

**MODELS OT35 & RT35** require 3-wire, grounded service rated 120/208 or 120/240 volts ac, 20 amp, single phase, 60 Hz.

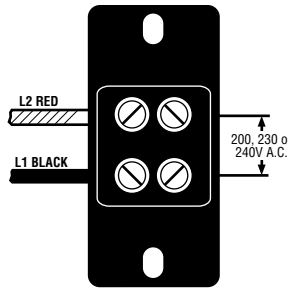

**MODELS OTA, RTA & RT35B** require 2-wire, grounded service rated 240 volts ac or 200 volts ac, 20 amp single phase, 50 Hz.

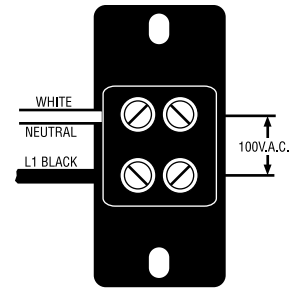

**MODEL RT** requires 2-wire, grounded service rated 120 volt ac, 25 amp single phase, 50 Hz.

### Electrical Hook-Up

Model OT15 has an attached cordset.

Models OT20, OT35, & RT35, proceed as follows:

**CAUTION** – Improper electrical installation will damage electronic components.

1. An electrician must provide electrical service as specified.
2. Using a voltmeter, check the voltage and color coding of each conductor at the electrical source.
3. Remove the front panel beneath the sprayhead and rotate the control thermostat knob fully counterclockwise to the “OFF” position and replace the panel.
4. Remove the rear panel, feed the cord through the strain relief, and connect it to the terminal block.
5. Connect the brewer to the power source and verify the voltage at the terminal block before proceeding. Replace the rear panel.
6. If plumbing is to be hooked-up later be sure the brewer is disconnected from the power source. If Plumbing has been hooked-up, the brewer is ready for Initial Set-Up.

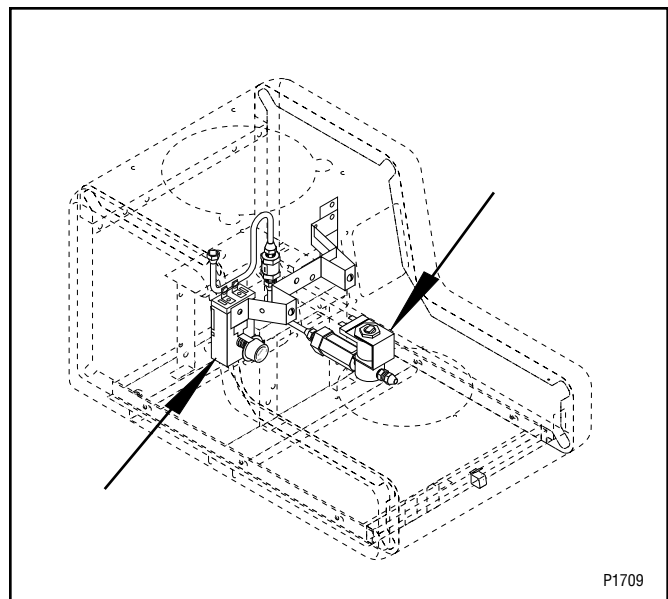

## PLUMBING REQUIREMENTS

This brewer must be connected to a **cold** water system with operating pressure between 20 and 90 psi from a 1/2" or larger supply line. A shut-off valve should be installed in the line before the brewer. Install a regulator in the line when pressure is greater than 90 psi to reduce it to 50 psi. The water inlet fitting is 1/4" flare.

**NOTE** - Bunn-O-Matic recommends 1/4" copper tubing for installations of less than 25 feet and 3/8" for more than 25 feet from the 1/2" water supply line. A tight coil of copper tubing in the water line will facilitate moving the brewer to clean the counter top. Bunn-O-Matic does not recommend the use of a saddle valve to install the brewer. The size and shape of the hole made in the supply line by this type of device may restrict water flow.

### Plumbing Hook-Up

Model OT15 has an attached water strainer, proceed to step 2.

Models OT20, OT35, & RT35, proceed as follows:

1. Remove the rear panel and bottom pan. Run the long piece of tubing from the strainer (supplied) under the brewer and attach it to the water inlet fitting on the solenoid. Reinstall the bottom pan and rear panel.
2. Flush the water line and securely attach it to the 1/4" flare fitting on the strainer.
3. Turn on the water supply.

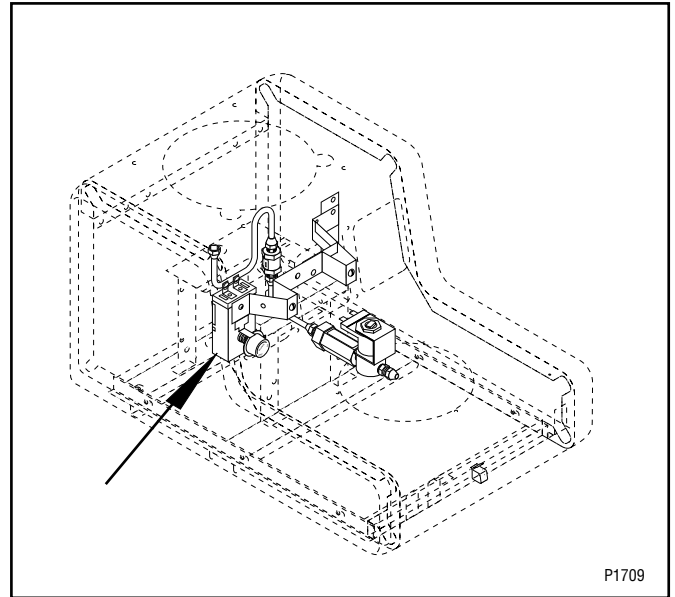

**As directed in the International Plumbing Code of the International Code Council and the Food Code Manual of the Food and Drug Administration (FDA), this equipment must be installed with adequate backflow prevention to comply with federal, state and local codes. For models installed outside the U.S.A., you must comply with the applicable Plumbing /Sanitation Code for your area.**

## INITIAL SETUP

**CAUTION** - The brewer must be disconnected from the power source throughout the initial set-up, except when specified in the instructions.

1. Remove the front panel.
  2. Rotate the control thermostat knob fully counter-clockwise to the "OFF" position and replace the panel.
  3. Insert an empty funnel into the funnel rails.
  4. Place a decanter containing a small amount of water on the warmer beneath the funnel.
  5. Connect the brewer to the power source, place the On/Off brew station warmer switch the upper position, and momentarily press the start switch. Water will begin flowing into the tank. When water stops flowing into the tank, initiate a second and a third brew cycle. During this third brew cycle the tank will fill to its capacity and the excess will flow from the spray-head, out of the funnel, and into the decanter.
- NOTE** - The On/Off brew station warmer switch must be in the upper position to initiate and complete a brew cycle.
6. Place the On/Off brew station warmer switch in the lower position.
  7. Disconnect the brewer from the power source.
  8. Remove the front panel.
  9. Rotate the control thermostat knob fully clockwise to the "ON" position and replace the front panel.
  10. Connect the brewer to the power source and wait approximately twenty minutes for the water in the tank to heat to the proper temperature. Some water will drip from the funnel during this time; this is due to expansion and should not occur thereafter.
  11. Place an empty decanter under the funnel.
  12. Place the On/Off brew station warmer switch in the upper position and momentarily press the start switch. Empty the decanter after water has stopped flowing from the funnel.
  13. Allow the water in the tank to reheat to the proper temperature.
  14. Place an empty decanter on the warmer and press the start switch. Check the water volume in the decanter after water has stopped flowing from the funnel. It should be 64 ounces.
  15. If not, adjust the Timer as described in Adjusting Brew Volumes (page 6)
  16. Repeat steps 13-15 until 64 oz water volume is achieved.

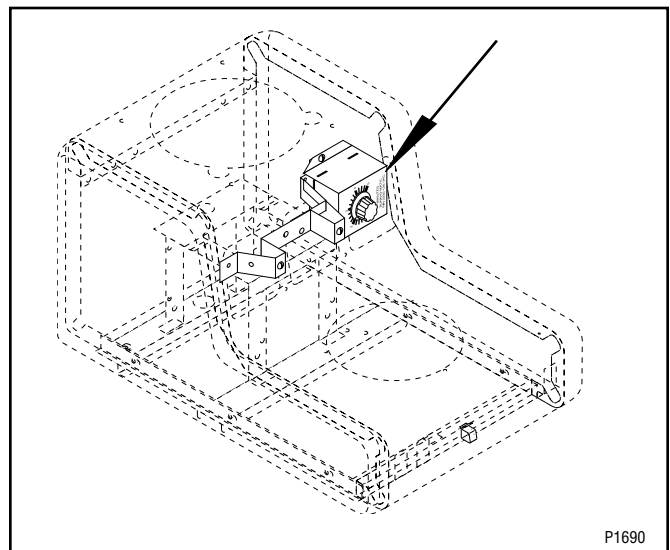
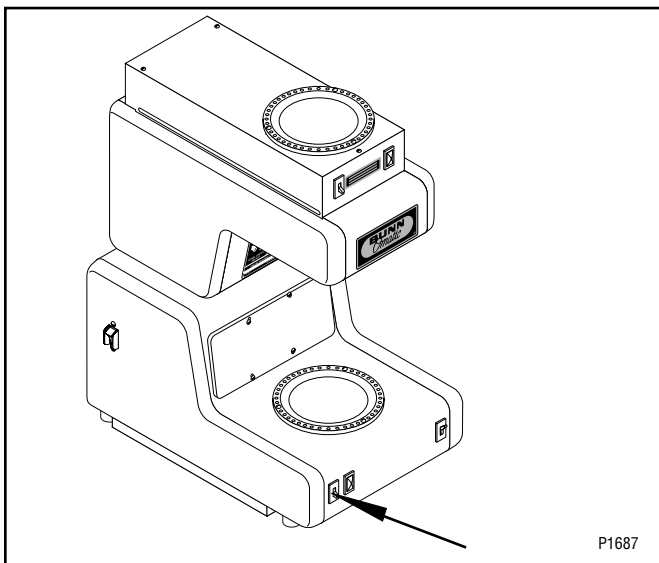

## ADJUSTING BREW VOLUMES

**CAUTION** - Disconnect the power source from the brewer prior to the removal of any panel for the replacement or adjustment of any component.

**NOTE:** Prior to setting or modifying batch sizes, check that the brewer is connected to water supply, the tank is properly filled, and a funnel and server are in place.

1. **Modifying batch sizes.** To modify a batch volume, first check that the SET/LOCK switch is in the “SET” position on the circuit board.

**To increase a batch size.** Press and hold the START or BREW switch until three clicks are heard. Release the switch (Failure to release the switch within two seconds after the third click causes the volume setting to be aborted and previous volume setting will remain in memory) and press it again one or more times. Each time the switch is pressed, two seconds are added to the brew time period. Allow the brew cycle to finish in order to verify that the desired volume has been achieved.

**To decrease a batch size.** Press and release the START or BREW switch once for every two-second interval to be removed from the total brew time period; then immediately press and hold down the START or BREW switch until three clicks are heard. Release the switch. (Failure to release the switch within two seconds after the third click causes the volume setting to be aborted and previous volume setting will remain in memory). Allow the brew cycle to finish in order to verify that the desired volume has been achieved.

2. **Setting batch sizes.** To set a batch volume, first check that the SET/LOCK switch is in the “SET” position on the circuit board. Press and hold the START or BREW switch until three distinct clicks are heard, and then release the switch. (Failure to release the switch within two seconds after the third click causes the volume setting to be aborted and previous volume setting will remain in memory). View the level of the liquid being dispensed. When the desired level is reached, turn the ON/OFF switch to “OFF” (lower). The brewer remembers this volume and will continue to brew batches of this size until the volume setting procedure is repeated.

**NOTE:** When brewing coffee, batch volumes will decrease due to absorption by the coffee grounds.

3. **Setting programming disable feature.** If it becomes necessary to prevent anyone from changing brew times once programmed, you can set the SET/LOCK switch to the “LOCK” position. This will prevent any programming to be done until switch is once again placed in the “SET” position.

## OPERATING CONTROLS

### MODELS OT & RT

#### A. On/Off Brew Station Warmer Switch

Placing the switch in the upper position supplies power to the brew station warmer and enables brewing. Placing the switch in the lower position cuts power to the brew station warmer and stops brewing. Stopping a brew cycle after it has been started will not stop the flow of water into the funnel until the tank syphons down to its proper level.

**NOTE** - The On/Off brew station warmer switch must be in the upper position to initiate and complete a brew cycle.

#### B. On/Off Brew Station Warmer Indicator Lamp

Glowes whenever the On/Off brew station warmer switch is in the upper position showing that the warmer is on and that the automatic brew cycle can be started.

#### C. Start Switch

Starts a brew cycle when the On/Off brew station warmer switch is in the upper position.

#### D. Upper Warmer Switch

Placing the switch in the upper position supplies power to the upper warmer. Placing the switch in the lower position cuts power to the upper warmer.

#### E. Upper Warmer Indicator Lamp

Glowes whenever the upper warmer switch is in the upper position showing that the warmer is on.

#### F. Left Rear Warmer Rotary Switch

Rotating the knob to the “ON” position supplies power to the left rear warmer. Rotating the knob to the “OFF” position cuts power to the left rear warmer.

#### G. Left Front Warmer Rotary Switch

Rotating the knob to the “ON” position supplies power to the left front warmer. Rotating the knob to the “OFF” position cuts power to the left front warmer.

#### H. Right Front Warmer Rotary Switch

Rotating the knob to the “ON” position supplies power to the right front warmer. Rotating the knob to the “OFF” position cuts power to the right front warmer.

#### I. Right Rear Warmer Rotary Switch

Rotating the knob to the “ON” position supplies power to the right rear warmer. Rotating the knob to the “OFF” position cuts power to the right rear warmer.

## MODEL OT

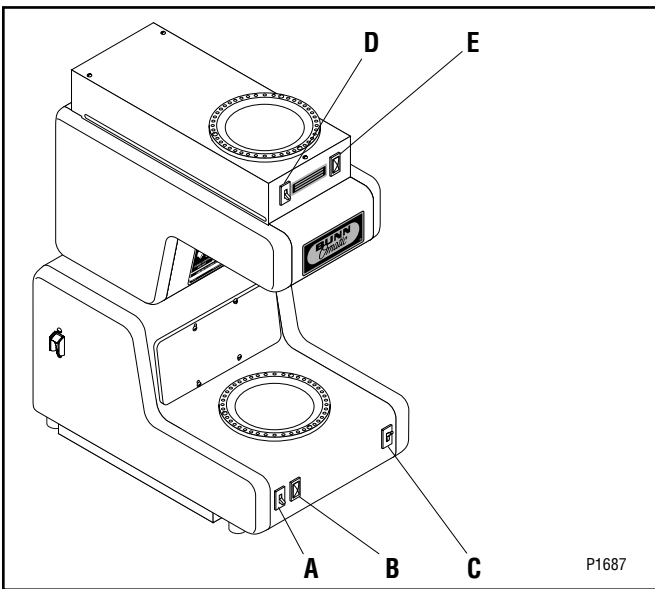

## MODEL RT

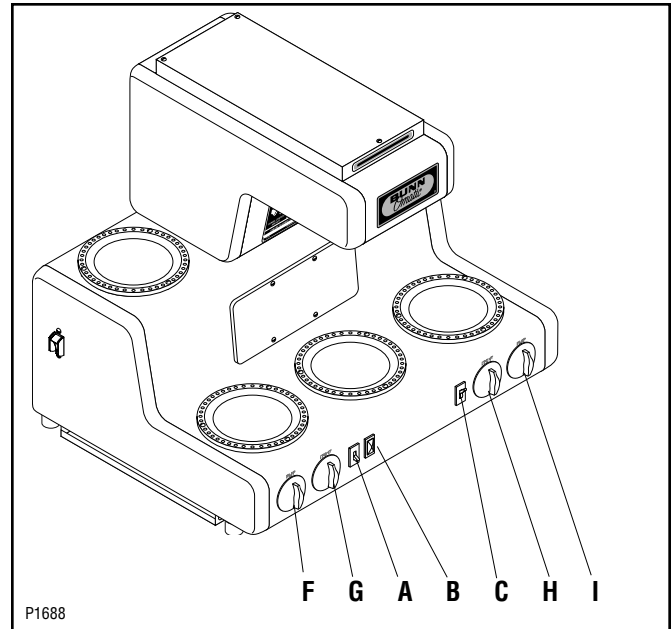

## COFFEE BREWING

Start each brew cycle with an empty, clean, half-gallon decanter.

1. Insert a BUNN® filter into the funnel.
2. Pour the fresh coffee into the filter and level the bed of grounds by gently shaking.
3. Slide the funnel into the funnel rails.
4. Place the On/Off brew station warmer switch in the upper position.
5. Momentarily press the start switch.
6. When brewing is completed, simply discard the grounds and filter.

## CLEANING

1. The use of a damp cloth rinsed in any mild, non-abrasive, liquid detergent is recommended for cleaning all surfaces on Bunn-O-Matic equipment.
2. Check and clean the sprayhead. The sprayhead holes must always remain open.
3. With the sprayhead removed, insert the deliming spring (provided) all the way into the sprayhead tube. When inserted properly, no more than two inches of spring should be visible. Saw back and forth five or six times. Then, repeat this step for the air vent tube.

**NOTE** - In hard water areas, this may need to be done daily. It will help prevent liming problems in the brewer and takes less than a minute.

## NEEDLE VALVE ADJUSTMENT (Models with Faucet)

This brewer is equipped with a unique faucet system allowing hot water to be drawn-off a cup-at-a-time for instant beverage needs, even while brewing.

**WARNING** - Disconnect the brewer from the power source before the removal of any panel or replacement of any component.

## ADJUSTMENT

1. Disconnect the brewer from the power source and remove the front inspection panel located beneath the brew funnel.
2. Adjust the needle valve as required to increase or decrease the pressure of the hot water flowing from the faucet. Turn the propeller on the valve in a counterclockwise direction to increase the flow and in a clockwise direction to decrease the flow.
3. Reconnect the brewer to the power source and allow the water in the tank to heat to the proper temperature before operating the brewer.



## TROUBLESHOOTING

A troubleshooting guide is provided to suggest probable causes and remedies for the most likely problems encountered. If the problem remains after exhausting the troubleshooting steps, contact the Bunn-O-Matic Technical Service Department.

- Inspection, testing, and repair of electrical equipment should be performed only by qualified service personnel.
- All electric components have 120 volt ac voltage on their terminals. Shorting of terminals or the application of external voltages may result in equipment failure.
- Intermittent operation of electronic equipment is unlikely. Component failure will normally be permanent. If an intermittent condition is encountered, the cause will likely be a switch contact or a loose connection at a terminal or crimp.
- Solenoid removal requires interrupting the water supply to the valve. Damage may result if solenoids are energized for more than ten minutes without a supply of water.
- The use of two wrenches is recommended whenever plumbing fittings are tightened or loosened. This will help to avoid twists and kinks in the tubing.
- Make certain that all plumbing connections are sealed and electrical connections tight and isolated.
- This brewer is heated at all times unless disconnected from the power source. Keep away from combustibles.

## WARNING

- Exercise extreme caution when servicing electrical equipment.
- Disconnect the brewer from the power source when servicing, except when electrical tests are specified.
- Follow recommended service procedures
- Replace all protective shields or safety notices

| <b>Problem</b>              | <b>Probable Cause</b>            | <b>Remedy</b>  |
|-----------------------------|----------------------------------|--|
| Equipment will not operate. | 1. No power or incorrect voltage | (A) Connect the brewer to the power source.<br><br>(B) Check the terminal block for the proper voltages.<br><br>(C) Check circuit breaker/fuse.  |
|                             | 1. No water                      | Check plumbing and shut-off valves.  |
|                             | 2. Water Strainer                | (A) Direction of flow arrow must be pointing towards brewer.<br><br>(B) Remove the strainer and check for obstructions. Clear or replace.        |
| Brew cycle will not start.  | 3. Flow Control                  | (A) Direction of flow arrow must be pointing away from the solenoid.<br><br>(B) Remove the control and check for obstructions. Clear or replace. |

## TROUBLESHOOTING (cont.)

| <b>Problem</b>  | <b>Probable Cause</b>  | <b>Remedy</b>  |
|---|--|--|
| Brew cycle will not start. (cont.)  | 4. On/Off Brew Station Warmer Switch   | Refer to Service - On/Off Brew Station Warmer Switch for testing procedures. See page 18.  |
|   | 5. Start Switch  | Refer to Service - Start Switch for testing procedures. See page 23.   |
|   | 6. Brew Timer  | Refer to Service - Timer for testing procedures. See page 13 & 14.   |
|   | 7. Solenoid Valve  | Refer to Service - Solenoid Valve for testing procedures. See page 22.   |
| Water flows into tank continuously (On/Off brew station warmer switch "OFF"). | 1. Solenoid Valve  | Refer to Service - Solenoid Valve for testing procedures. See page 22.   |
| Water flows into tank continuously (On/Off brew station warmer switch "ON").  | 1. Brew Timer  | Refer to Service - Timer for testing procedures. See page 13 & 14.   |
| Water is not hot.   | 1. Limit Thermostat  | Refer to Service - Limit Thermostat for testing procedures. See page 21.   |
|   | <b>CAUTION</b><br>Do not eliminate or bypass limit thermostat. Use only B.O.M. replacement part <b>#29329.1000</b> |  |
|   | 2. Control Thermostat  | Refer to Service - Control Thermostat for testing procedures. See page 16.   |
| Decanter warmer is not hot.   | 3. Tank Heater   | Refer to Service - Tank Heater for testing procedures. See page 24.  |
|   | 1. Warmer Switches   | (A) The Warmer Switch(es) must be in the "ON" position for the warmer to operate.<br><br>(B) Refer to Service - Warmer Switch(es) for testing procedures. See pages 18 & 19. |
|   | 2. Decanter Warmers  | Refer to Service - Warmers for testing procedures. See page 17.  |

## TROUBLESHOOTING (cont.)

| <b>Problem</b>                                       | <b>Probable Cause</b>   | <b>Remedy</b>   |
|--|---|---|
| Spitting or unusual steaming from sprayhead.         | 1. Control Thermostat   | Refer to Service - Control Thermostat for testing procedures. See page 16.  |
|  | 2. Lime build-up  | Inspect the tank assembly for excessive lime deposits. Delime as required.  |
|  | <b>CAUTION</b><br>Tank and tank components should be delimed regularly depending on local water conditions. Excessive mineral build-up on stainless steel surfaces can initiate corrosive reactions resulting in serious leaks. |   |
| Inconsistent beverage level in decanter.             | 1. Flow control   | (A) Direction of flow arrow must be pointing away from the solenoid.<br><br>(B) Remove the control and check for obstructions. Clear or replace.  |
|  | 2. Improper water pressure  | Check the operating water pressure to the brewer. It must be between 20 and 90 psi (138 and 620 kPa).   |
|  | 3. Syphon system  | Water should flow freely from the sprayhead for approximately twenty seconds after the brew solenoid has shut-off and then stop flowing abruptly. The brewer must be level from front-to-back to syphon properly. |
| Consistently high or low beverage level in decanter. | 1. Brew Timer adjustment  | Adjust the brew timer as required to achieve the recommended 64 oz for each brew cycle.   |
| Dripping from sprayhead.                             | 1. Syphon system  | Water should flow freely from the sprayhead for approximately twenty seconds after the brew solenoid has shut-off and then stop flowing abruptly. The brewer must be level from front-to-back to syphon properly. |
|  | 2. Solenoid Valve   | Refer to Service - Solenoid Valve for testing procedures. See page 22.  |

## TROUBLESHOOTING (cont.)

| <b>Problem</b>                   | <b>Probable Cause</b>        | <b>Remedy</b>   |
|----------------------------------|------------------------------|---|
| Beverage overflows decanter.     | 1. Beverage left in decanter | The brew cycle should be started only with an empty decanter under the funnel.  |
| Weak beverage.                   | 1. Type of paper filters     | BUNN® paper filters should be used for proper extraction.   |
|                                  | 2. Coffee                    | A sufficient quantity of fine or drip grind coffee should be used for proper extraction.  |
|                                  | 3. Sprayhead                 | B.O.M. sprayhead #01082.0000 should be used to properly wet the bed of ground coffee in the funnel.   |
|                                  | 4. Funnel loading            | The BUNN® paper filter should be centered in the funnel and the bed of coffee leveled by gentle shaking.  |
|                                  | 5. Water temperature         | Place a funnel over an empty decanter on the warmer beneath the sprayhead. Place the On/Off brew station warmer switch in the upper position, press the start switch, and check the water temperature immediately below the sprayhead with an accurate thermometer. The reading should not be less than 195° F. Adjust the control thermostat slightly clockwise to increase the water temperature. |
| Brewer is making unusual noises. | 1. Solenoid Valve            | The nut on top of the solenoid valve must be tight or it will vibrate during operation.   |
|                                  | 2. Plumbing lines            | Plumbing lines should not rest on the counter top.  |
|                                  | 3. Water supply              | (A) The brewer must be connected to a cold water line.<br><br>(B) Water pressure to the brewer must not be higher than 90 psi (620 kPa). Install a regulator if necessary to lower the working pressure to approximately 50 psi (345 kPa).  |

# SERVICE

This section provides procedures for testing and replacing various major components used in this brewer should service become necessary. Refer to Troubleshooting for assistance in determining the cause of any problem.

## Component Access

**WARNING** - Disconnect the brewer from the power source before the removal of any panel or the replacement of any component.

The brew timer, and control thermostat are located behind the front panel, FIG. 1 located beneath the brew funnel, attached with four #8-32 slotted-head screws.

The base warmer(s), switch(es), indicator lamp, start switch, tank “keep warm” heater, terminal block, and solenoid valve, are located in the base. Access is gained by removing the rear panel, FIG. 1 attached with two #8-32 slotted-head screws

The limit thermostat, and tank heater are located on the tank lid. Access is gained by removing the top lid, FIG. 1 attached with three #8-32 slotted head screws. On the model OT, the upper warmer, switch, and associated indicator lamp are located on this removable top lid.

**WARNING** - Inspection, testing, and repair of electrical equipment should be performed only by qualified service personnel. The brewer should be disconnected from the power source when servicing, except when electrical tests are required and the test procedure specifically states to connect the brewer to the power source.

## Contents

|  |    |
|--|----|
| Brew Timer (Early Models).....   | 13 |
| Digital Timer (Late Models).....   | 14 |
| Control Thermostat.....  | 16 |
| Warmer(s)  |    |
| OT: Brew Station & Upper .....   | 17 |
| RT: Left Rear, Left Front, Brew Station, Right Rear<br>& Right Front ..... | 17 |
| Warmer Switch(es)  |    |
| OT: On/Off Brew Station & Upper .....                                      | 18 |
| RT: On/Off Brew Station.....   | 18 |
| RT: Left Rear, Left Front, Right Rear<br>& Right Front Rotary.....         | 19 |
| Indicator Lamp(s) .....  | 20 |
| Limit Thermostat.....  | 21 |
| Solenoid Valve .....   | 22 |
| Start Switch .....   | 23 |
| Tank Heater .....  | 24 |
| Thermal Cut-off .....  | 25 |
| Master ON/OFF Switch.....  | 26 |
| Wiring Schematics .....  | 27 |

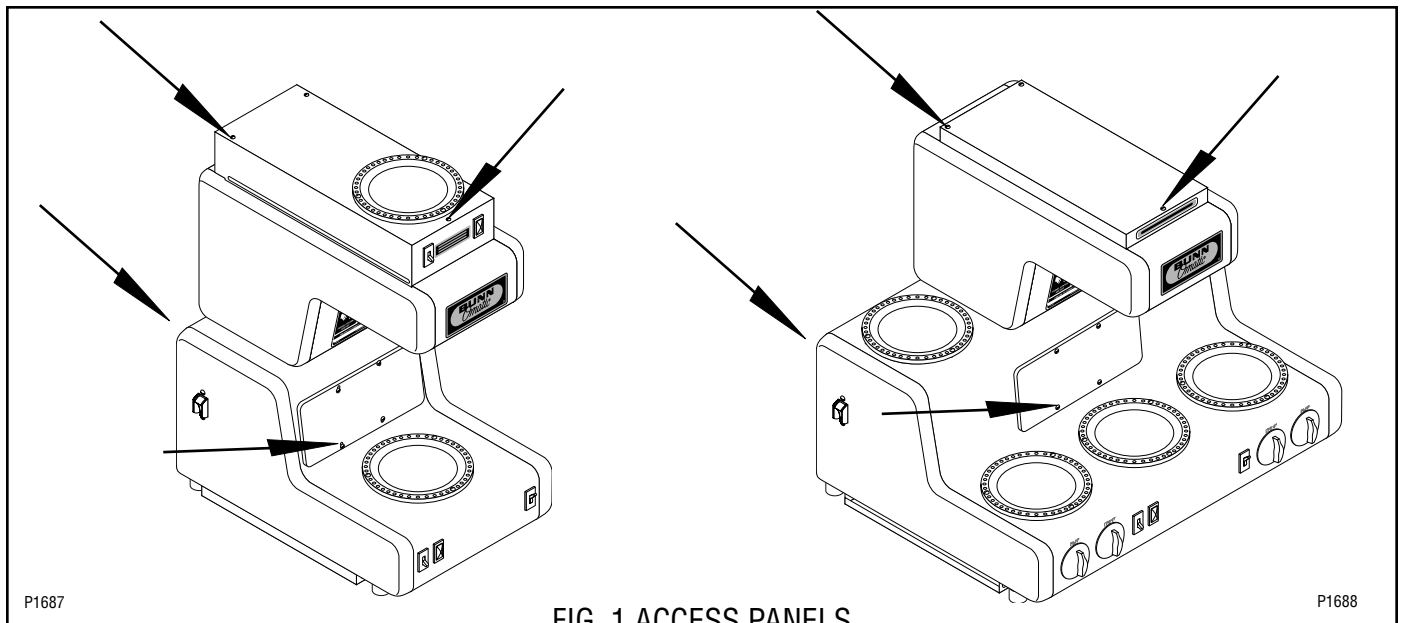

FIG. 1 ACCESS PANELS

## SERVICE (cont.)

### Brew Timer (Early Models)

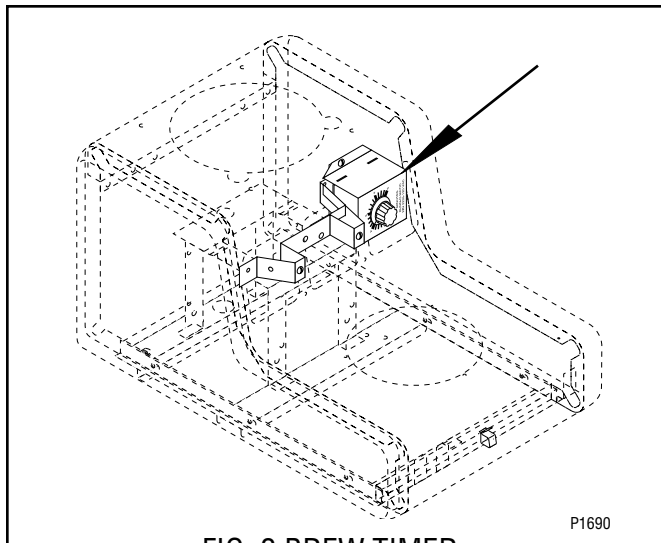

FIG. 2 BREW TIMER

#### Location:

The brew timer is located behind the front panel to the right of the tank, FIG. 2.

#### Test Procedure:

1. Disconnect the brewer from the power source and separate the polarized, three-pin connectors between the timer and brewer wiring harness and rotate the brew timer dial fully counterclockwise.
2. Check the voltage across sockets 2 & 3 (white or red and black wires) of the female connector with a voltmeter when the On/Off brew station warmer switch is in the upper position. Connect the brewer to the power source. The indication must: a) 120 volts ac for two wire 120 volt models.  
b) 200 or 240 volts ac for two wire 200 volt or 240 volt models and three wire 120/240 volt models.  
c) 100 volts ac for two wire 100 volt models.
3. Disconnect the brewer from the power source.

If voltage is present as described, proceed to #4.

If voltage is not present as described, refer to the Wiring Diagrams and check the brewer wiring harness.

4. Check the voltage across sockets 1 & 2 (blue and white or red wires) of the female connector with a voltmeter when the On/Off brew station warmer switch is in the upper position and the start switch is pressed to the lower position and held. Connect the brewer to the power source. The indication must be as described in step 2, until the start switch is released.
5. Disconnect the brewer from the power source.

If voltage is present as described, reconnect the polarized, three-pin connectors, and proceed to #6.

If voltage is not present as described, refer to the Wiring Diagrams and check the brewer wiring harness.

6. Disconnect the in-line connectors on the black and white wires from the timer to the solenoid.
7. Check the voltage across the black and white wires with a voltmeter when the On/Off brew station warmer switch is in the upper position and the start switch is pressed to the lower position and released. Connect the brewer to the power source. The indication must be as described in step 2, for approximately 20 seconds and then return to its previous indication.
8. Disconnect the brewer from the power source.

If voltage is present as described, the brew timer is operating properly. Reset the timer dial as required, to obtain the desired brew volume.

If voltage is not present as described, replace the brew timer.

#### Removal and Replacement:

1. Separate all connectors between the brewer wiring harness and the timer.
2. Remove the two 8-32 slotted-head screws holding the timer to the bracket.
3. Install the new timer to the bracket.
4. Refer to FIG.3 when reconnecting the wires.
5. Readjust the timer dial as required.

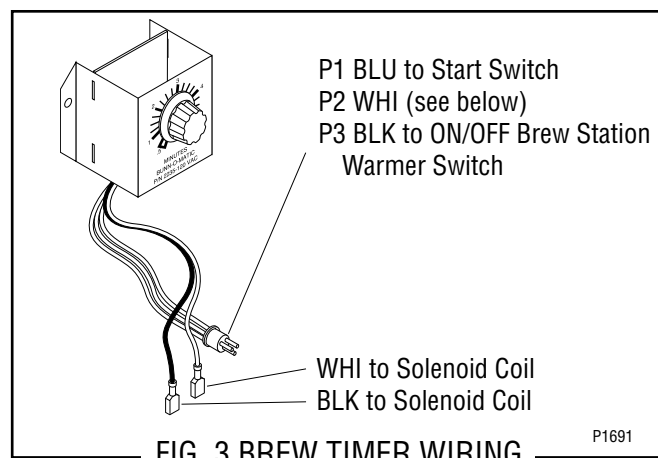

FIG. 3 BREW TIMER WIRING

#### MODEL

OT WHI to Indicator Lamp

RT WHI to Brew Station Warmer

## SERVICE (cont.)

### DIGITAL BREW TIMER (Late Models)

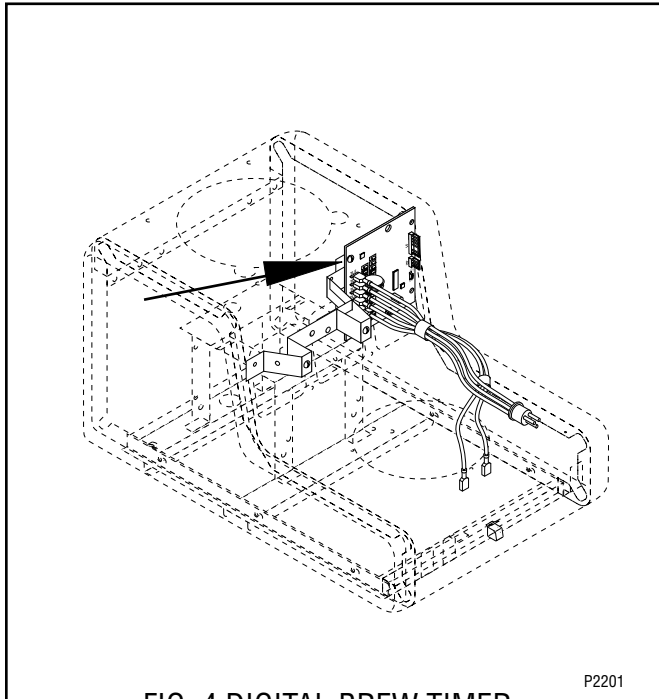

FIG. 4 DIGITAL BREW TIMER

#### Location:

The timers are located inside the front of the trunk on the upper right side of the component brackets.

#### Test Procedure.

**NOTE:** Do not remove or install wires while timer board is installed. Pressure applied to one side may cause damage to the board.

1. Disconnect the brewer from the power source and remove the front access panel.
2. Remove the one #8-32 screw securing circuit board to the mounting bracket.
3. Remove circuit board and spacers (as required).
4. With a voltmeter, check the voltage across terminals TL1 and TL2 when the "ON/OFF" switch is in the "ON" position. Connect the brewer to the power source. The indication must be:
  - a) 120 volts ac for two wire 120 volt models.
  - b) 200 or 240 volts ac for two wire 200 or 240 volt models and three wire 120/240 volt models.
  - c) 100 volts ac for two wire 100 volt models.
5. Disconnect the brewer from the power source.

If voltage is present as described, proceed to #6.  
If voltage is not present as described, refer to the *Wiring Diagrams* and check the brewer wiring harness.

6. Disconnect the white/blue wire from terminal TL3 and the blue/black wire from terminal TL5. With a voltmeter, check for continuity across the two wires when the "ON/OFF" switch is in the "ON" position (upper) and the START switch is pressed. Connect the brewer to the power source. The indication must be:
  - a) 120 volts ac for two wire 120 volt models.
  - b) 200 or 240 volts ac for two wire 200 or 240 volt models and three wire 120/240 volt models.
  - c) 100 volts ac for two wire 100 volt models.

If continuity is present as described, reconnect the wires and proceed to #7.

If continuity is not present as described, refer to the *Wiring Diagrams* and check the brewer wiring harness.

7. With a voltmeter, check the voltage across terminals TL1 and TL4 when the "ON/OFF" switch is in the "ON" position. Connect the brewer to the power source. The indication must be 0 volts.

If voltage is as described, proceed to #8.

If voltage is not as described, disconnect the brewer from the power source and replace the timer.

8. With a voltmeter, check the voltage across terminals TL1 and TL4 when the "ON/OFF" switch is in the "ON" position. Connect the brewer to the power source and press the "START" switch. The indication must be as follows:
  - a) 120 volts ac for two wire 120 volt models.
  - b) 200 or 240 volts ac for two wire 200 or 240 volt models and three wire 120/240 volt models.
  - c) 100 volts ac for two wire 100 volt models.

If voltage is present as described, the brew timer is operating properly. Reset the timer as required, to obtain the desired brew volume.

If voltage is not present as described, disconnect the brewer from the power source and replace the timer.

#### Removal and Replacement:

1. Remove the one #8-32 screw securing circuit board to the mounting bracket.
2. Remove circuit board and spacers (as required).

## SERVICE (cont.)

### DIGITAL BREW TIMER (Late Models)(cont.)

3. Remove all wires from the timer.
4. Attach all wires to the replacement timer board prior to installation to the component mounting bracket. Refer to FIG. 5 when reconnecting the wires.
5. Install new circuit board with spacers (as required) to the component mounting bracket.
6. Adjust the timer as described below.

#### Timer Setting:

**NOTE:** Prior to setting or modifying volumes, check that the brewer is connected to water supply, the tank is properly filled, and a funnel and server are in place.

**NOTE:** All volume settings must be done with the sprayhead installed.

1. **Modifying brew volumes.** To modify a brew volume, first check that the SET/LOCK switch is in the “SET” position on the circuit board.

**To increase a brew volume,** place the ON/OFF switch in the “ON” position, press and hold the START switch until three clicks are heard. Release the switch and press it again one or more times. (Failure to release the switch within two seconds after the third click causes the volume setting to be aborted and previous volume setting will remain in memory.) Each time the switch is pressed, two seconds are added to the brew time period. Allow the brew cycle to finish in order to verify that the desired volume has been achieved.

**To decrease a brew volume,** place the ON/OFF switch in the “ON” position, press and release the START switch once for every two-second interval to be removed from the total brew time period; then immediately press and hold down the START switch until three clicks are heard. Release the switch. (Failure to release the switch within two seconds after the third click causes the volume setting to be aborted and previous volume setting will remain in memory). Allow the brew cycle to finish in order to verify that the desired volume has been achieved.

2. **Setting brew volumes.** To set a brew volume, first check that the SET/LOCK switch is in the “SET” position on the circuit board. Place the ON/OFF switch in the “ON” position, press and hold the START switch until three distinct clicks are heard and then release the switch. (Failure to release the switch within two seconds after the third click causes the volume setting to be aborted and previous volume setting will remain in memory.)

View the level of the liquid being dispensed. When the desired level is reached, turn the ON/OFF switch to “OFF”.

**NOTE:** Several ounces of water will continue to syphon from the tank after turning the switch “OFF”. The brewer remembers this volume and will continue to brew batches of this size until the volume setting procedure is repeated.

**NOTE:** When brewing coffee, volume will decrease due to absorption by the coffee grounds.

3. **Setting programming disable feature.** If it becomes necessary to prevent anyone from changing brew time once programmed, you can set the SET/LOCK switch to the “LOCK” position. This will prevent any further programming until switch is once again put into the “SET” position.

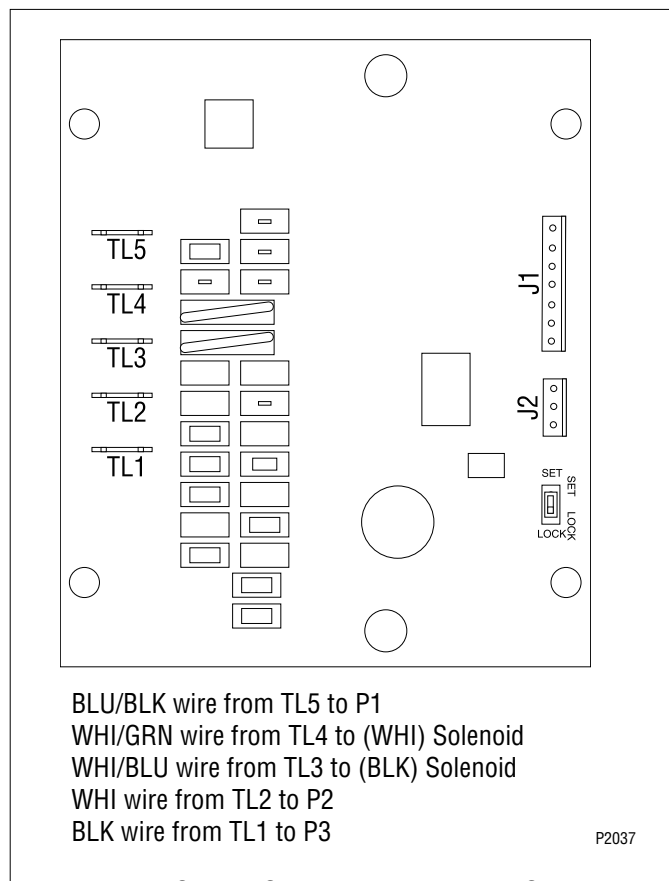

FIG. 5 DIGITAL TIMER WIRING



## SERVICE (cont.)

### Control Thermostat

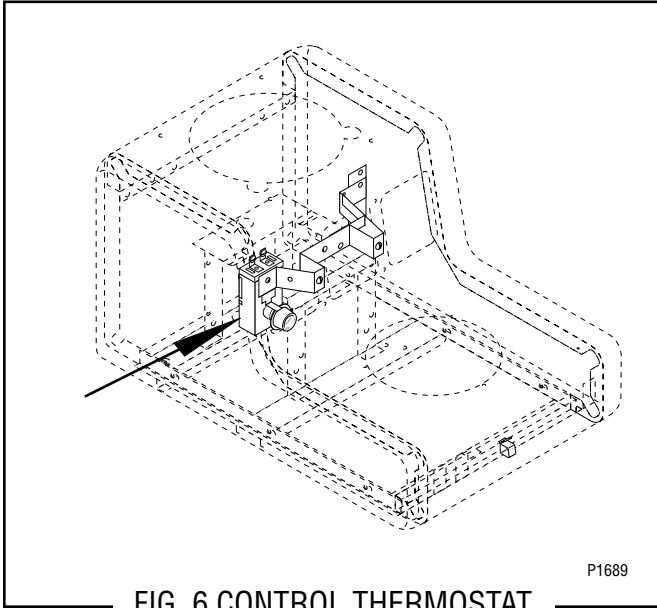

FIG. 6 CONTROL THERMOSTAT

#### Location:

The control thermostat is located behind the front panel, FIG. 6 to the left of the tank.

To test the control thermostat, access will also be needed to the tank heater located in the top of the brewer.

#### Test Procedure:

1. Disconnect the brewer from the power source.
2. Check the voltage across the blue wire on the control thermostat and the white or red wire on the tank heater with a voltmeter. Connect the brewer to the power source. The indication must be:
  - a) 120 volts ac for two wire 120 volt models.
  - b) 200 or 240 volts ac for two wire 200 volt or 240 volt models and three wire 120/240 volt models.
  - c) 100 volts ac for two wire 100 volt models.
3. Disconnect the brewer from the power source.

If voltage is present as described, proceed to #4. If voltage is not present as described, refer to the Wiring Diagrams and check the brewer wiring harness.

4. Check the voltage across the black wire terminal of the control thermostat and the white or red wire on the tank heater with a voltmeter when the control thermostat is turned "ON" (fully clockwise). Connect the brewer to the power source. The indication must be as described in step 2. Voltage must not be indicated across

these terminals when the thermostat is turned "OFF" (fully counterclockwise).

5. Disconnect the brewer from the power source.

If voltage is present as described, the control thermostat is operating properly.

If voltage is not present as described, replace the control thermostat.

#### Removal and Replacement:

1. Remove both wires from the control thermostat terminals.
2. Remove the top lid from the brewer to gain access to the thermostat bulb.
3. Remove the thermostat bulb by firmly pulling-up on the capillary tube at the tank lid. This will disengage the grommet from the tank lid.
4. Remove the two #8-32 screws holding the control thermostat to the bracket.
5. Fasten the new control thermostat to the brewer housing.
6. Route the capillary tube up through the brewer trunk.

**NOTE** - Make sure that the capillary tube is away from any electrical termination and is not kinked.

7. Slide the grommet to the red mark on the capillary tube.
8. Insert the bulb through the hole in the tank lid and press the grommet firmly and evenly so that the groove in the grommet fits into the tank lid.
9. Carefully bend the capillary tube so that the tube and bulb inside the tank are in a vertical position.
10. Refer to FIG. 7 when reconnecting the wires.
11. Readjust the control thermostat dial as required.

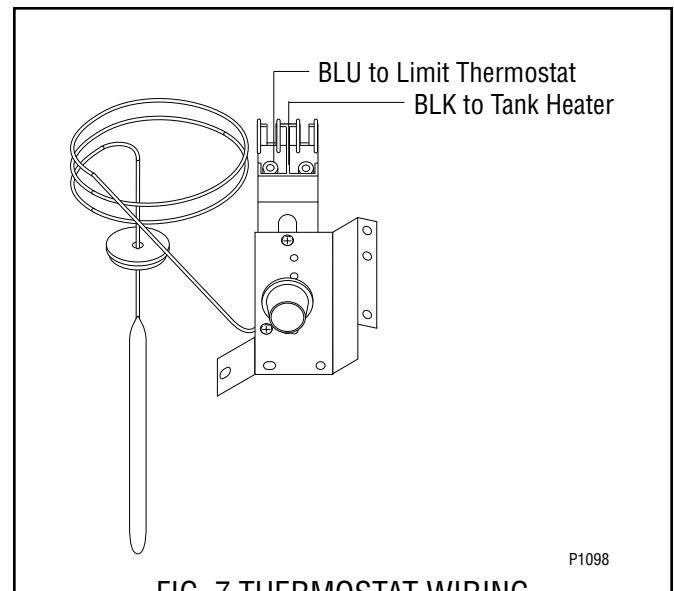

FIG. 7 THERMOSTAT WIRING

## SERVICE (cont.)

### Warmer(s)

OT: Brew Station & Upper

RT: Left Rear, Left Front, Brew Station, Right Rear & Right Front

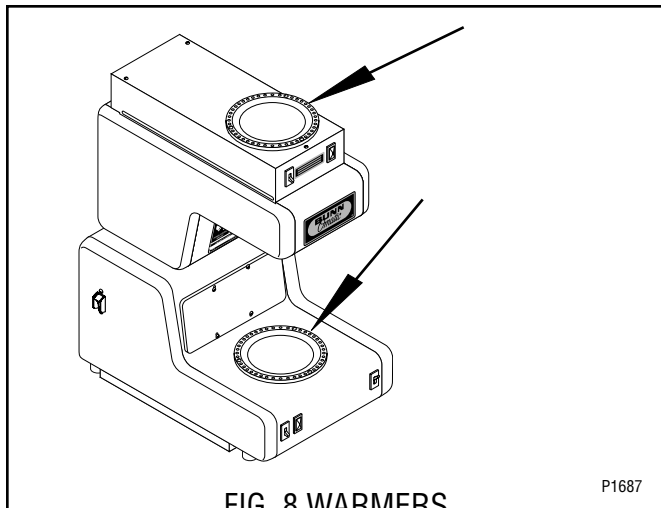

FIG. 8 WARMERS

P1687

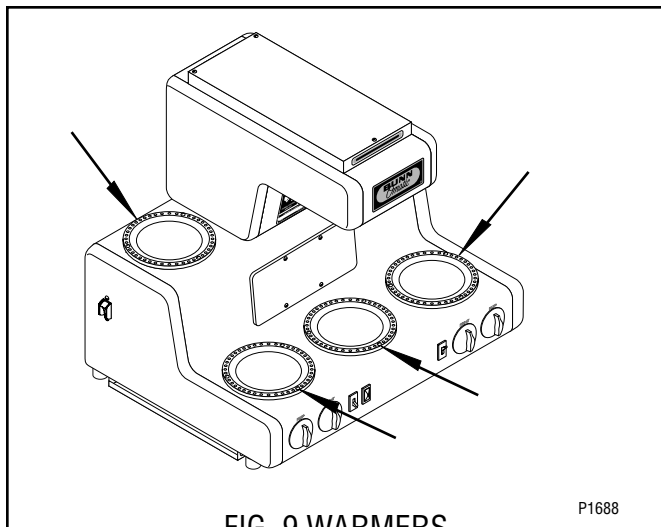

FIG. 9 WARMERS

P1688

### Location:

OT: One of the warmers is beneath the brew funnel and the other is on the top lid, FIG. 8.

RT: These warmers include the one beneath the brew funnel, the ones on the right and left of the brew station, and the one above and to the left and right of the brew station as viewed from the front, FIG. 9.

### Test Procedure:

1. Once the switch has been tested and switch failure has been eliminated, proceed as follows.
2. Disconnect the brewer from the power source and remove the #4-40 screws attaching the warmer being tested.
3. Lift the warmer assembly from the brewer and invert the warmer making the wire terminals accessible for testing.
4. Check for continuity from the switch to the black wire at the warmer element.

If continuity is present as described, proceed to #5.

5. Check for continuity from the wire terminal of the white or red wire to the splice or indicator lamp using the chart below.

If continuity is present as described, proceed to #6. If continuity is not present as described, refer to the Wiring Diagrams and check the brewer wiring harness.

6. Check for continuity across the two terminals on the warmer.

If continuity is present as described, the warmer is operating properly.

If continuity is not present as described, replace the warmer.

### Removal and Replacement:

1. Remove the #4-40 slotted-head screws holding the warmer to the brewer
2. Lift the warmer assembly from the brewer.
3. Disconnect both wires from the warmer.
4. Refer to FIG. 10 when reconnecting the wires.
5. Place the new warmer into the brewer and securely attach it using the #4-40 screws.

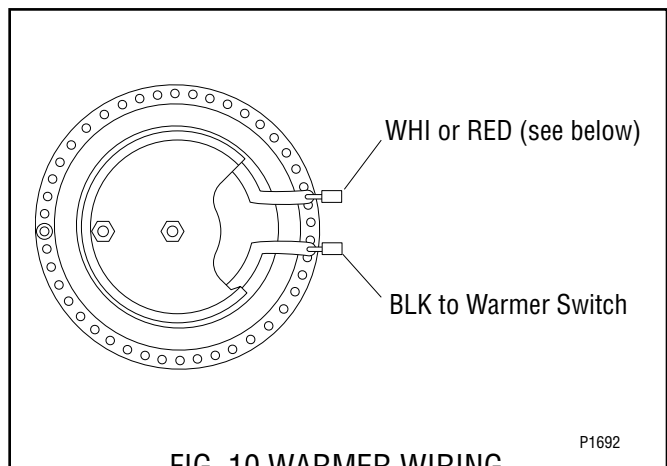

FIG. 10 WARMER WIRING

P1692

### MODEL

|                 |            |   |
|-----------------|------------|---|
| OT Upper        | WHI OR RED | to Indicator Lamp                           |
| OT Brew Station | WHI OR RED | to Indicator Lamp<br>to Terminal Block      |
| RT Left Rear    | WHI OR RED | to Terminal Block<br>to Brew Station Warmer |
| RT Left Front   | WHI OR RED | to Indicator Lamp<br>to Terminal Block      |
| RT Brew Station | WHI OR RED | to Timer P2<br>to Left Rear Warmer          |
| RT Right Front  | WHI OR RED | to Right Rear Warmer<br>to Indicator Lamp   |
| RT Right Rear   | WHI OR RED | to Right Front Warmer                       |

## SERVICE (cont.)

### Warmer Switch(es)

OT: On/Off Brew Station & Upper

RT: On/Off Brew Station

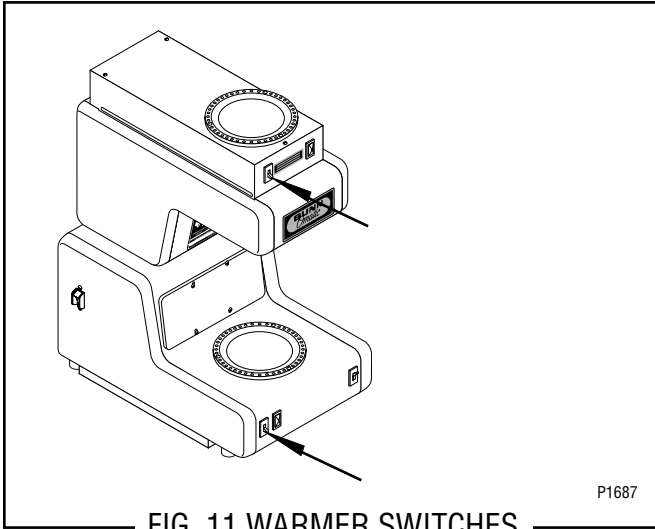

FIG. 11 WARMER SWITCHES

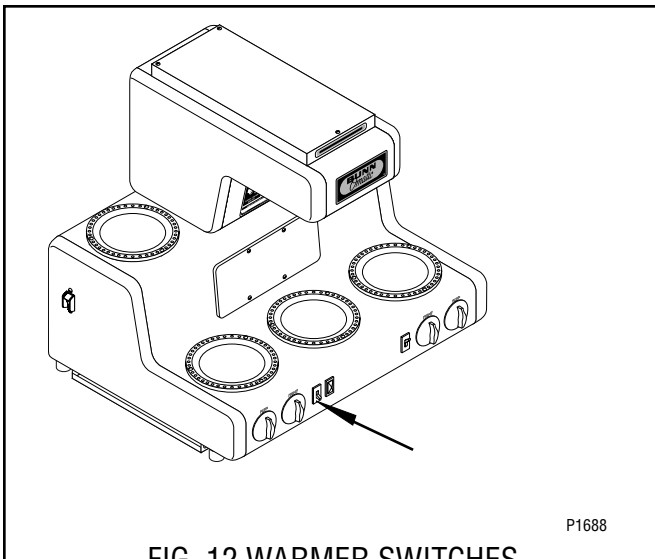

FIG. 12 WARMER SWITCHES

#### Location:

These switches are located beneath and to the left of their associated warmers as viewed from the front, FIG.s 11 and 12.

#### Test Procedure:

1. Locate the switch terminal with black wires that do not go to the nearby indicator lamp.
2. Check the voltage across this terminal and the terminal on the indicator lamp with white or red wires with a voltmeter. Connect the brewer to the power source. The indication must be:
  - a) 120 volts ac for two wire 120 volt models.
  - b) 200 or 240 volts ac for two wire 200 volt or 240 volt models and three wire 120/240 volt models.
  - c) 100 volts ac for two wire 100 volt models.
3. Disconnect the brewer from the power source.

If voltage is present as described, proceed to #4. If voltage is not present as described, refer to the Wiring Diagrams and check the brewer wiring harness.

4. Check the voltage across the other switch terminal and the terminal on the indicator lamp with white or red wires with a voltmeter when the switch is in the upper position. Connect the brewer to the power source. The indication must be as described in step 2. Voltage must not be present across these terminals in the lower position.
5. Disconnect the brewer from the power source.

If voltage is present as described the switch is operating properly.

If voltage is not present as described, replace the switch.

#### Removal and Replacement:

1. Compress the clips inside the housing and gently push the switch through the opening.
2. Remove the wires from the switch terminals.
3. Refer to FIG. 13 when reconnecting the wires.
4. Push the new switch firmly into the opening.

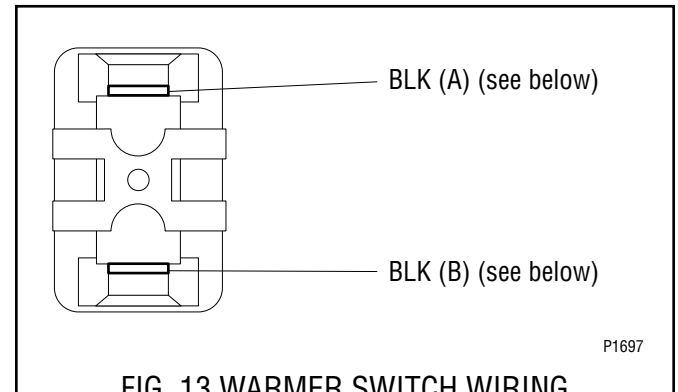

FIG. 13 WARMER SWITCH WIRING

#### MODEL

OT Upper  
 BLK A to Warmer  
 to Indicator Lamp  
 BLK B to Harness P3

#### OT On/Off Brew Station

BLK A to Indicator Lamp  
 to Brew Station Warmer  
 to Timer P3  
 BLK B to Terminal Block

#### RT On/Off Brew Station

BLK A to Indicator Lamp  
 to Timer P3  
 to Brew Station Warmer  
 BLK B to Left Front Warmer Switch  
 to Right Front Warmer Switch

## SERVICE (cont.)

### Warmer Switch(es)

RT: Left Rear, Left Front, Right Rear & Right Front

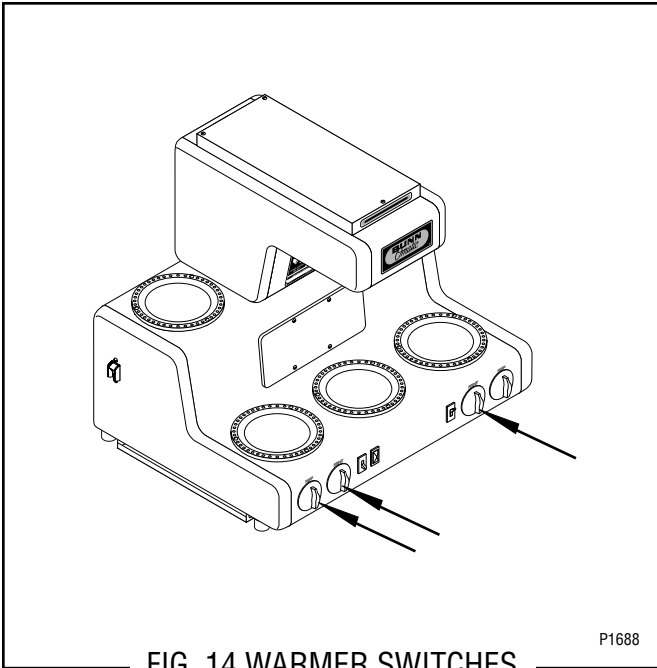

FIG. 14 WARMER SWITCHES

#### Location:

These warmer switches are the two at the left and the left most one on the right of the base as viewed from the front, FIG. 14. Their knobs are marked Off/On/Off/On.

To test these switches, access will also be needed to the terminal block located in the rear of the brewer.

#### Test Procedure:

- Check the voltage across terminal L1 and the white or red wire on the terminal block with a voltmeter. Connect the brewer to the power source. The indication must be:
  - 120 volts ac for two wire 120 volt models.
  - 200 or 240 volts ac for two wire 200 volt or 240 volt models and three wire 120/240 volt models.
  - 100 volts ac for two wire 100 volt models.
- Disconnect the brewer from the power source.

If voltage is present as described, proceed to #3.

If voltage is not present as described, refer to the Wiring Diagrams and check the brewer wiring harness.

- Check the voltage across terminal 1 and the white or red wire on the terminal block with a voltmeter when the switch is in the "ON" position. Connect the brewer to the power source. The indication must be as described in step 1. Voltage must not be present across these terminals in the "OFF" positions.
- Disconnect the brewer from the power source.

If voltage is present as described, the switch is operating properly.

If voltage is not present as described, replace the switch.

#### Removal and Replacement:

- Remove the knob from the switch.
- Loosen the 5/8" nut on the switch shaft and push the switch through the opening.
- Remove the wires from the switch terminals.
- Refer to FIG. 15 when reconnecting the wires.
- Securely mount the new switch onto the housing and reinstall the knob.

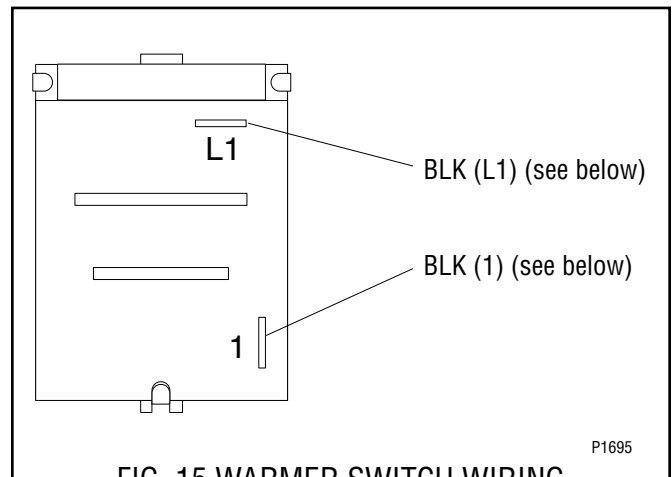

FIG. 15 WARMER SWITCH WIRING

#### MODEL

|                |        |   |
|----------------|--------|---|
| RT Left Rear   | BLK L1 | to Warmer   |
|                | BLK 1  | to Left Front Warmer Switch   |
| RT Left Front  | BLK L1 | to Warmer   |
|                | BLK 1  | to Left Rear Warmer Switch<br>to Brew Station Warmer Switch                       |
| RT Right Front | BLK L1 | to Warmer   |
|                | BLK 1  | to Terminal Block<br>to Brew Station Warmer Switch<br>to Right Rear Warmer Switch |
| RT Right Rear  | BLK L1 | to Warmer   |
|                | BLK 1  | to Right Front Warmer Switch  |

## SERVICE (cont.)

### Indicator Lamp(s)

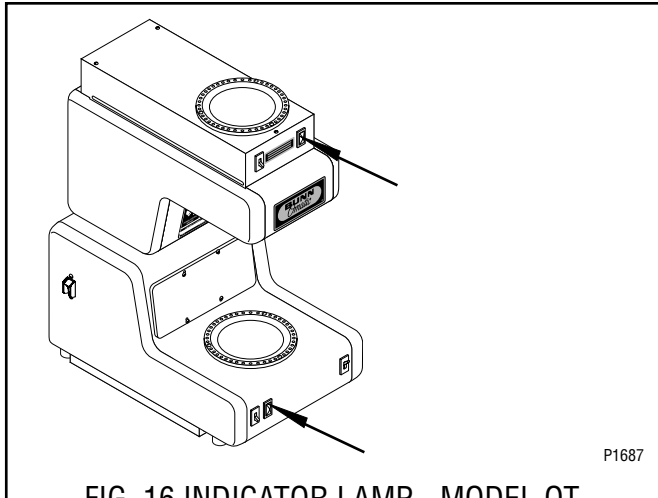

FIG. 16 INDICATOR LAMP - MODEL OT

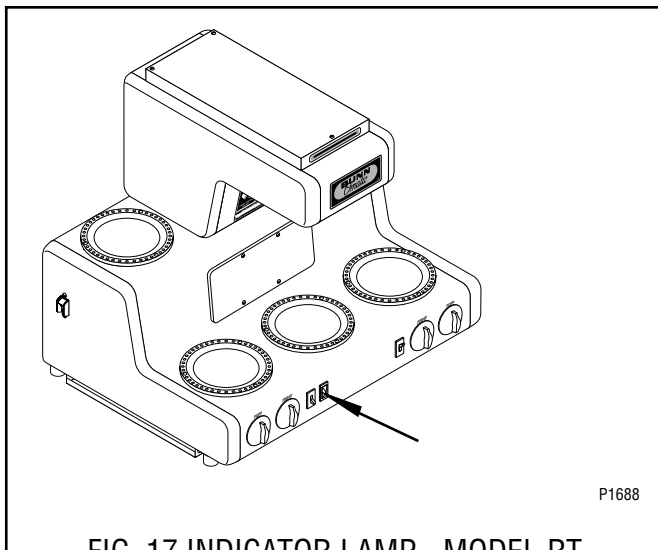

FIG. 17 INDICATOR LAMP - MODEL RT

#### Location:

The indicator lamps are located beneath their associated warmers, FIG.s 16 and 17.

#### Test Procedure:

1. Check continuity of the black wire from the switch to the indicator lamp.
2. Check continuity of the white or red wire from the indicator lamp to the terminal block.

If continuity is present, proceed to #3.

If continuity is not present, refer to Wiring Diagrams and check brewer wiring harness.

3. Check for voltage across the indicator lamp terminals. Connect the brewer to the power source. The indication must be:
  - a) 120 volts ac for two wire 120 volt models.
  - b) 200 or 240 volts ac for two wire 200 volt or 240 volt models and three wire 120/240 volt models.
  - c) 100 volts ac for two wire 100 volt models.

4. Disconnect the brewer from the power source.

If voltage is present, the indicator lamp is operating properly.

If voltage is not present, replace the indicator lamp.

#### Removal and Replacement:

1. Compress the clips inside the housing and gently push the indicator lamp through the opening.
2. Remove the wires from the indicator lamp terminals.
3. Refer to FIG. 18 when reconnecting the wires.
4. Push the new indicator lamp firmly into the opening.

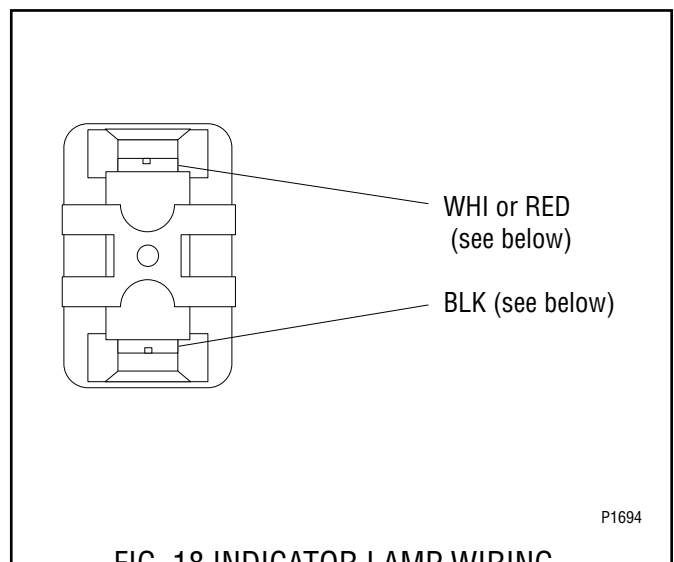
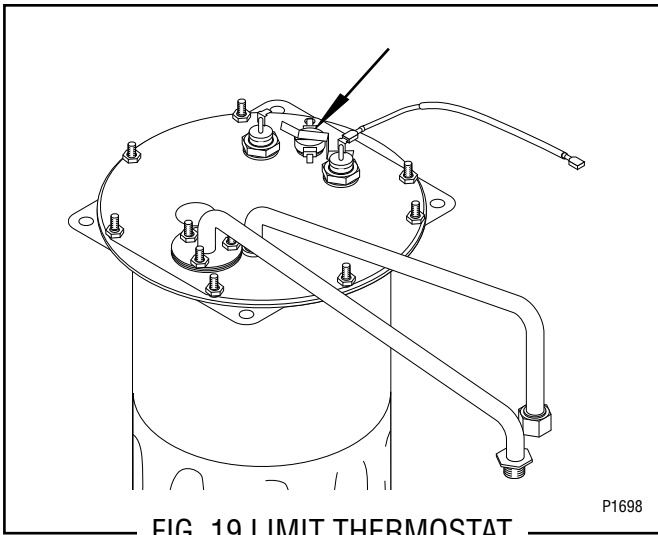

FIG. 18 INDICATOR LAMP WIRING

|          |            |  |
|----------|------------|--|
| MODEL    |            |  |
| OT Upper | BLK        | to Warmer Switch   |
|          | WHI or RED | to Warmer<br>to Harness P2                                 |
| OT Lower | BLK        | to Start Switch<br>to On/Off Brew Station Warmer<br>Switch |
|          | WHI or RED | to Timer P2<br>to Brew Station Warmer                      |
| RT       | BLK        | to Start Switch<br>to On/Off Brew Station Warmer<br>Switch |
|          | WHI or RED | to Right Front Warmer<br>to Left Front Warmer              |

## SERVICE (cont.)

### Limit Thermostat



#### Location:

The limit thermostat is located on the tank lid between the tank heater terminals, FIG. 19.

#### Test Procedure:

1. Disconnect the brewer from the power source.
2. Check voltage across the black wire from the limit thermostat and the white or red wire on the tank heater terminal. Connect the brewer to the power source. The indication must be:
  - a) 120 volts ac for two wire 120 volt models.
  - b) 200 or 240 volts ac for two wire 200 volt or 240 volt models and three wire 120/240 volt models.
  - c) 100 volts ac for two wire 100 volt models.
3. Disconnect the brewer from the power source.

If voltage is present as described, proceed to #4.

If voltage is not present as described, refer to the Wiring Diagrams and check the brewer wiring harness.

4. Check for continuity across the limit thermostat terminals.

If continuity is present as described, the limit thermostat is operating properly.

If continuity is not present as described, replace the limit thermostat.

#### Removal and Replacement:

1. Remove both wires from the limit thermostat terminals.
2. Carefully slide the limit thermostat out from under the retaining clip.
3. Carefully slide the new limit thermostat into the retaining clip.
4. Refer to FIG. 20 when reconnecting the wires.

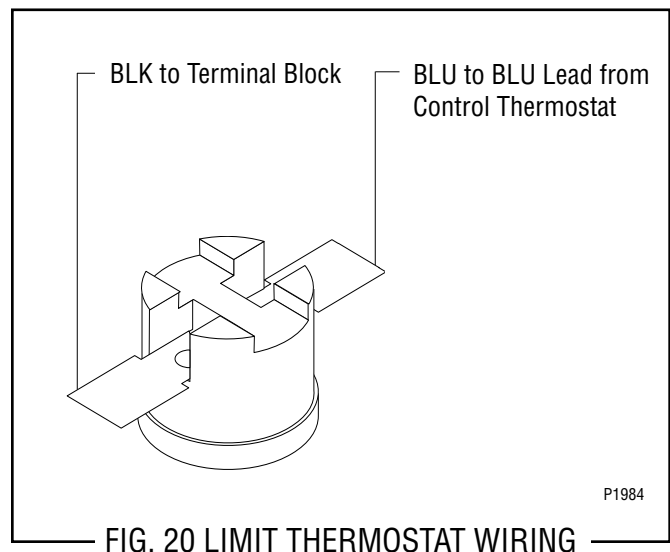

## SERVICE (cont.)

### Solenoid Valve

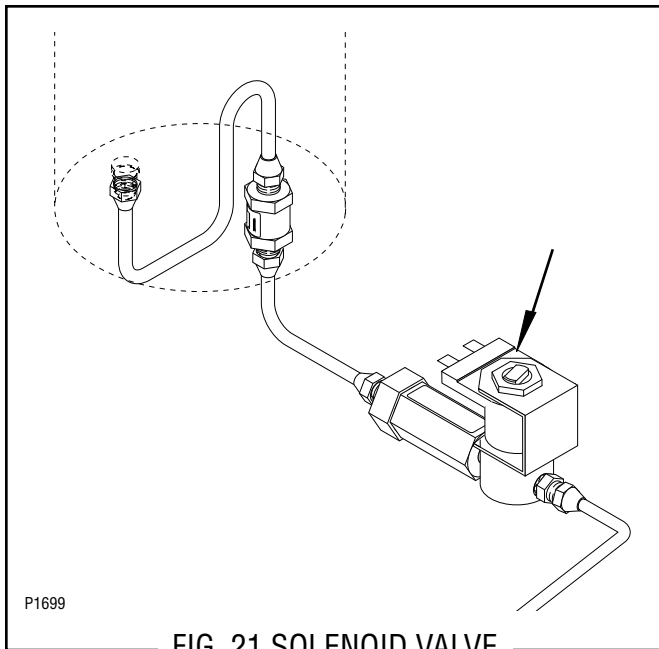

FIG. 21 SOLENOID VALVE

#### Location:

The solenoid valve is located below and to the left of the tank as viewed from the rear, FIG. 21.

#### Test Procedure:

1. Check the voltage across the white and black wires with a voltmeter when the On/Off brew station warmer switch is in the upper position and the start switch is pressed to the lower position and released. Connect the brewer to the power source. The indication must be:
  - a) 120 volts ac for two wire 120 volt models and three wire 120/240 volt models,
  - b) 200 or 240 volts ac for two wire 200 volt or 240 volt models,
  - c) 100 volts ac for two wire 100 volt models, for the approximate setting on the brew timer dial and then return to zero.
2. Disconnect the brewer from the power source.

If voltage is present as described, proceed to #3.  
If voltage is not present as described, refer to the Wiring Diagrams and check the brewer wiring harness.

3. Check for continuity across the solenoid valve coil terminals.

If continuity is present as described, reconnect the white and black wires and proceed to #4.  
If continuity is not present as described, replace the solenoid valve.

4. Check the solenoid valve for coil action. Connect the brewer to the power source, place the On/Off brew station warmer switch in the upper position, press and release the start switch. Listen carefully in the vicinity of the solenoid valve for a “clicking” sound as the coil magnet attracts and after the approximate setting on the brew timer dial, repels the plunger.
5. Disconnect the brewer from the power source.

If the sound is heard as described and water will not pass through the solenoid valve, there may be a blockage in the water line before or after the solenoid valve or, the solenoid valve may require inspection for wear, and removal of waterborne particles.

If the sound is not heard as described, replace the solenoid valve.

#### Removal and Replacement:

1. Remove all wires from the solenoid valve coil.
2. Turn off the water supply to the brewer.
3. Remove the bottom pan attached with one or more 8-32 slotted-head screw(s) beneath the front of the brewer.
4. Raise the brewer approximately six inches from the counter top and support the feet on something sturdy.
5. Disconnect the water lines to and from the solenoid valve.
6. Remove the two 10-32 screws holding the solenoid valve to the bracket.
7. Lift-out the solenoid valve.
8. Securely install the new solenoid valve to the bracket. Check the direction of flow arrow on the valve. It must be pointing toward the flow control.
9. Securely fasten the water lines to and from the solenoid valve.
10. Refer to FIG. 22 when reconnecting the wires.

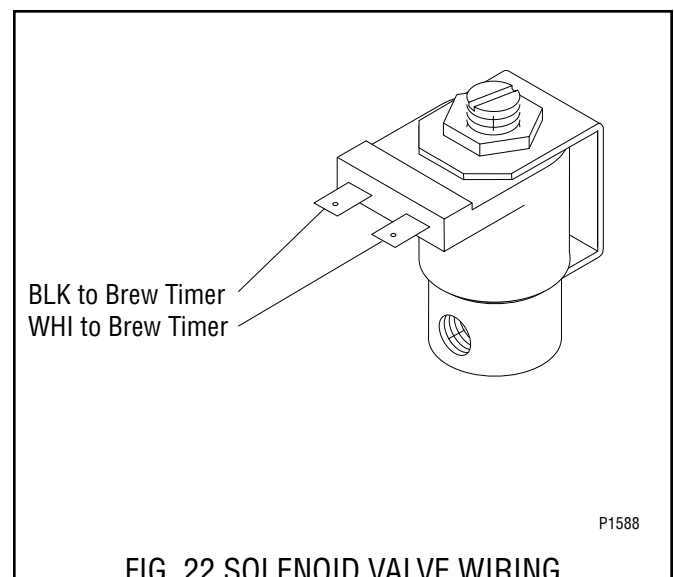
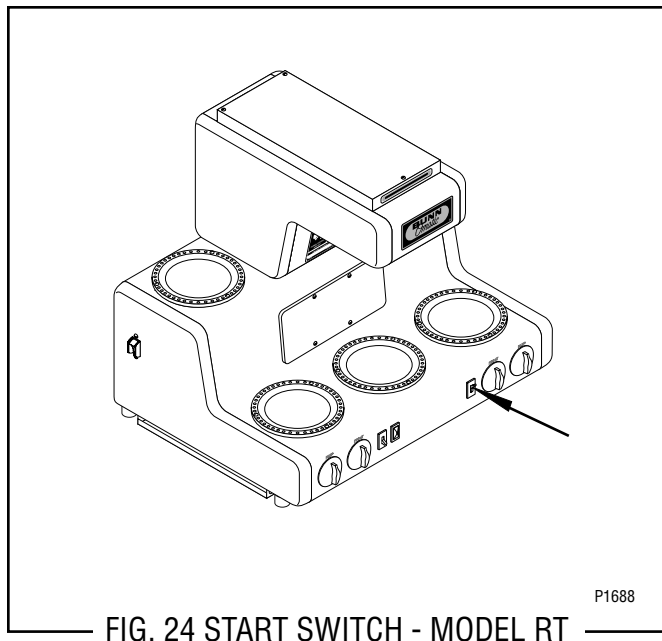
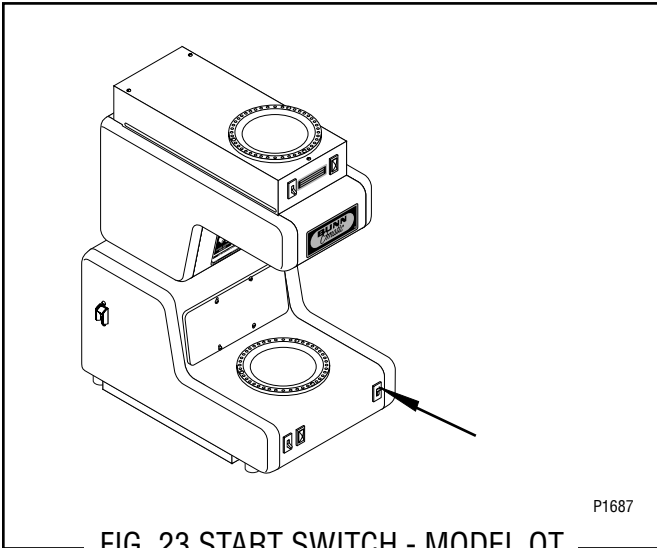

FIG. 22 SOLENOID VALVE WIRING

## SERVICE (cont.)

### Start Switch



#### Location:

The start switch is located in the base, below and to the right of the brew station, FIG.s 23 & 24.

#### Test Procedure:

1. Disconnect the brewer from the power source and remove the wires from both terminals of the start switch.
2. Check for continuity across the two terminals on the switch when it is held in the lower position. Continuity must not be present across these terminals in the upper position.

If continuity is present as described, reconnect the wires, the switch is operating properly. If continuity is not present as described, replace the switch.

#### Removal and Replacement:

1. Remove all wires from the switch terminals.
2. Compress the clips inside the housing and gently push the switch through the opening.
3. Push the new switch into the opening and spread the clips to hold the switch captive in the housing.
4. Refer to FIG. 25 when reconnecting the wires.

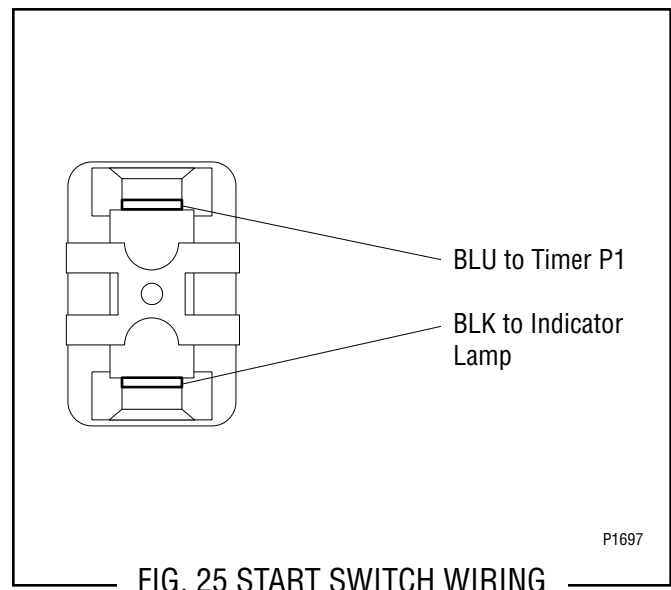



## SERVICE (cont.)

### Tank Heater

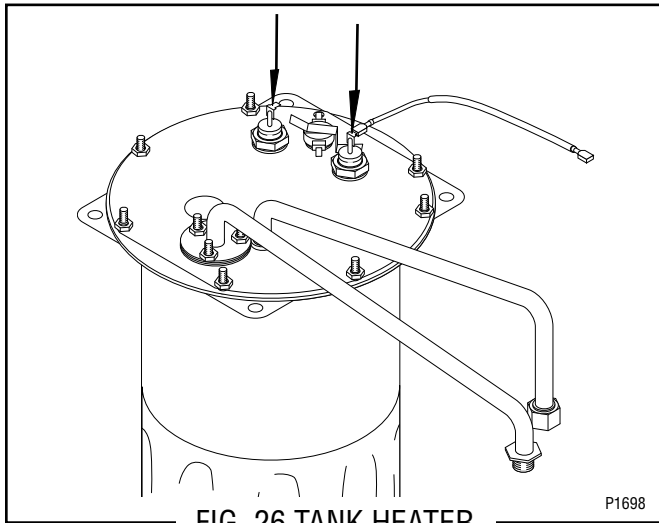

#### Location:

The tank heater is located on the tank lid, FIG. 26.

#### Test Procedure:

1. Check the voltage across the black and white or red wires on the tank heater with a voltmeter when the control thermostat is turned "ON" (fully clockwise). Connect the brewer to the power source. The indication must be:
  - a) 120 volts ac for two wire 120 volt models.
  - b) 200 or 240 volts ac for two wire 200 volt or 240 volt models and three wire 120/240 volt models.
  - c) 100 volts ac for two wire 100 volt models.
2. Disconnect the brewer from the power source.

If voltage is present as described, proceed to #3.  
If voltage is not present as described, refer to the Wiring Diagrams and check the brewer wiring harness.

3. Check for continuity across the terminals of the tank heater.

If continuity is present as described, reconnect the wires, the tank heater is operating properly.  
If continuity is not present as described, replace the tank heater.

**NOTE** - If the tank heater remains unable to heat, remove and inspect the heater for cracks in the sheath.

#### Removal and Replacement:

1. Remove the wires to the tank heater and limit thermostat terminals.
2. Gently pull the thermostat tube with grommet out of the tank lid.
3. Remove the sprayhead and sprayhead nut from the panel on the bottom of the hood.
4. Disconnect the air vent tube from the fitting above the sprayhead panel.
5. On units with faucet, disconnect the inlet and outlet tubes from the faucet coil fittings.
6. Loosen the eight 8-32 nuts on the tank lid and remove the tank lid.
7. Remove the two nuts from the tank heater fittings.
8. Remove the tank heater.
9. Install the new tank heater with new sealing washers on the underside of the tank lid.
10. Securely tighten the nuts to be certain of a watertight seal.
11. Reinstall the tank lid and tighten the eight nuts.
12. Reconnect the air vent tube to the fitting above the sprayhead panel.
13. Reconnect the inlet and outlet tubes to the faucet coil fittings on units with faucet.
14. Reinstall the sprayhead tube nut and sprayhead.
15. Reinstall the thermostat into the tank lid.
16. Refer to FIG. 27 when reconnecting the wires.

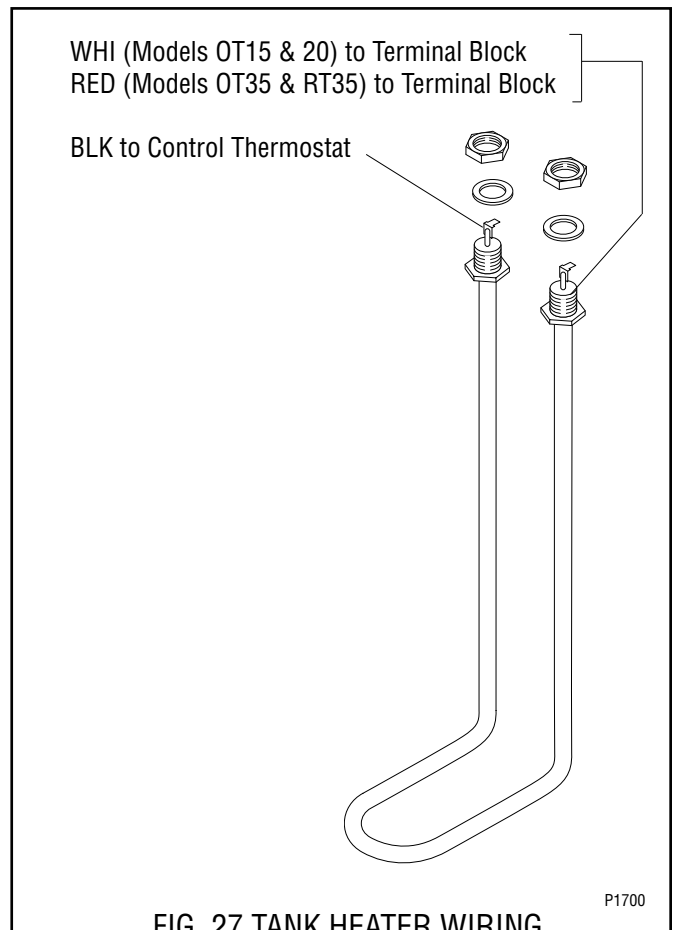

FIG. 27 TANK HEATER WIRING

## SERVICE (cont.)

### Thermal Cut-off

Location:

The thermal cut-off is located on the tank heater, FIG. 28.

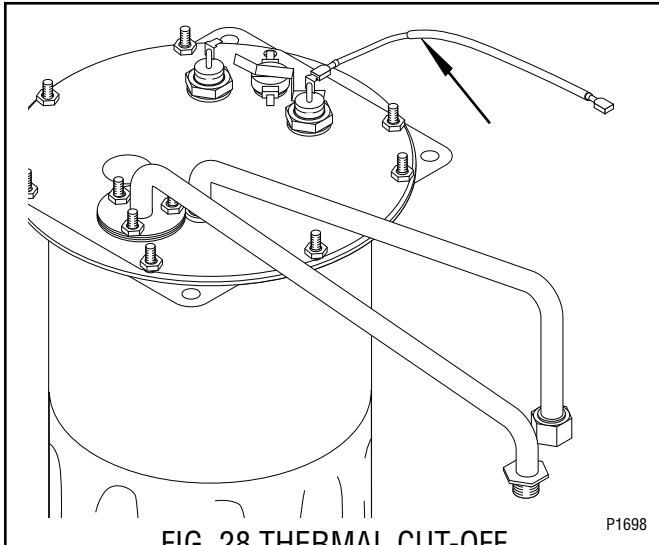

Test Procedures:

1. Disconnect the brewer from the power source.
2. Disconnect the thermal cut-off from the tank heater terminal and the wiring harness.
3. Check for continuity across the thermal cut-off terminals using an ohmmeter.

If continuity is present, the thermal cut-off is operating properly. If continuity is not present as described, replace the thermal cut-off.

Removal and Replacement:

1. Disconnect the thermal cut-off from the tank heater terminal and the wiring harness.
2. Remove thermal cut-off and discard.
3. Connect new thermal cut-off to the tank heater terminal and the wiring harness.

## SERVICE (cont.)

### Master ON/OFF Switch

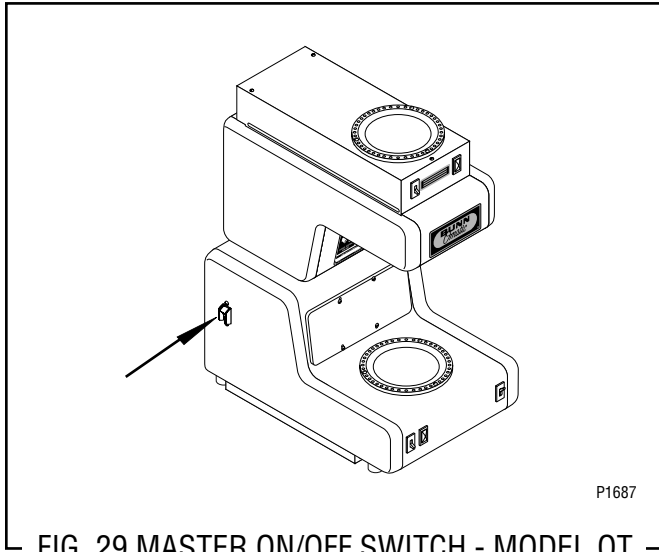

FIG. 29 MASTER ON/OFF SWITCH - MODEL OT

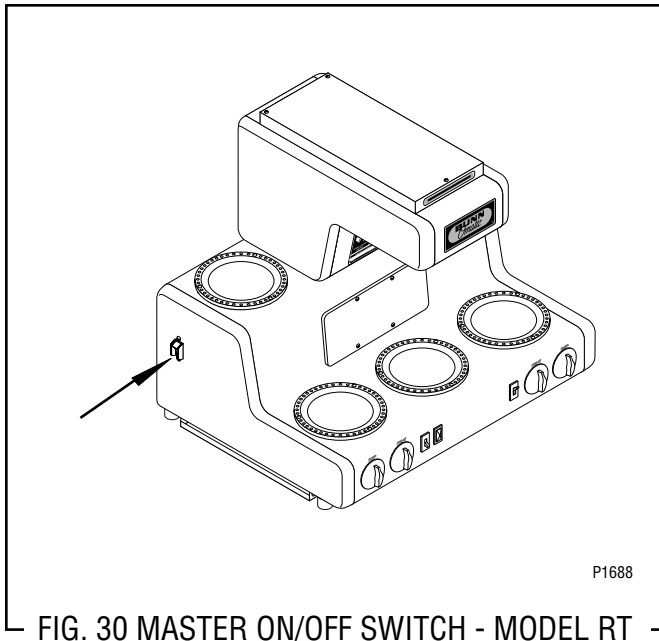

FIG. 30 MASTER ON/OFF SWITCH - MODEL RT

#### Location:

The Master ON/OFF switch is located in the base, at the left rear, FIG.s 29 & 30.

#### Test Procedure:

1. Disconnect the brewer from the power source and remove the wires from all terminals of the Master ON/OFF switch.

2. Check for continuity across the two terminals on the switch at L1 BLK and BLK to Main Harness when it is held in the lower position, Fig. 25. Check for continuity across the two terminals on the switch at L2 RED and RED to Main Harness when it is held in the lower position. Continuity must not be present across these terminals in the upper position.

If continuity is present as described, reconnect the wires, the switch is operating properly. If continuity is not present as described, replace the switch.

#### Removal and Replacement:

1. Remove all wires from the switch terminals.
2. Remove the two screws from the outside of the base and gently push the switch through the opening.
3. Locate the new switch into the opening and secure with screws removed in step 2.
4. Refer to FIG. 31 when reconnecting the wires.

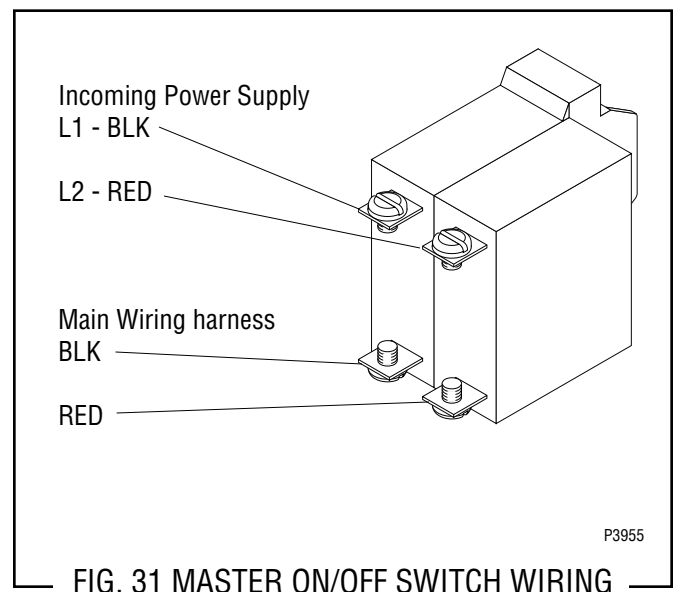
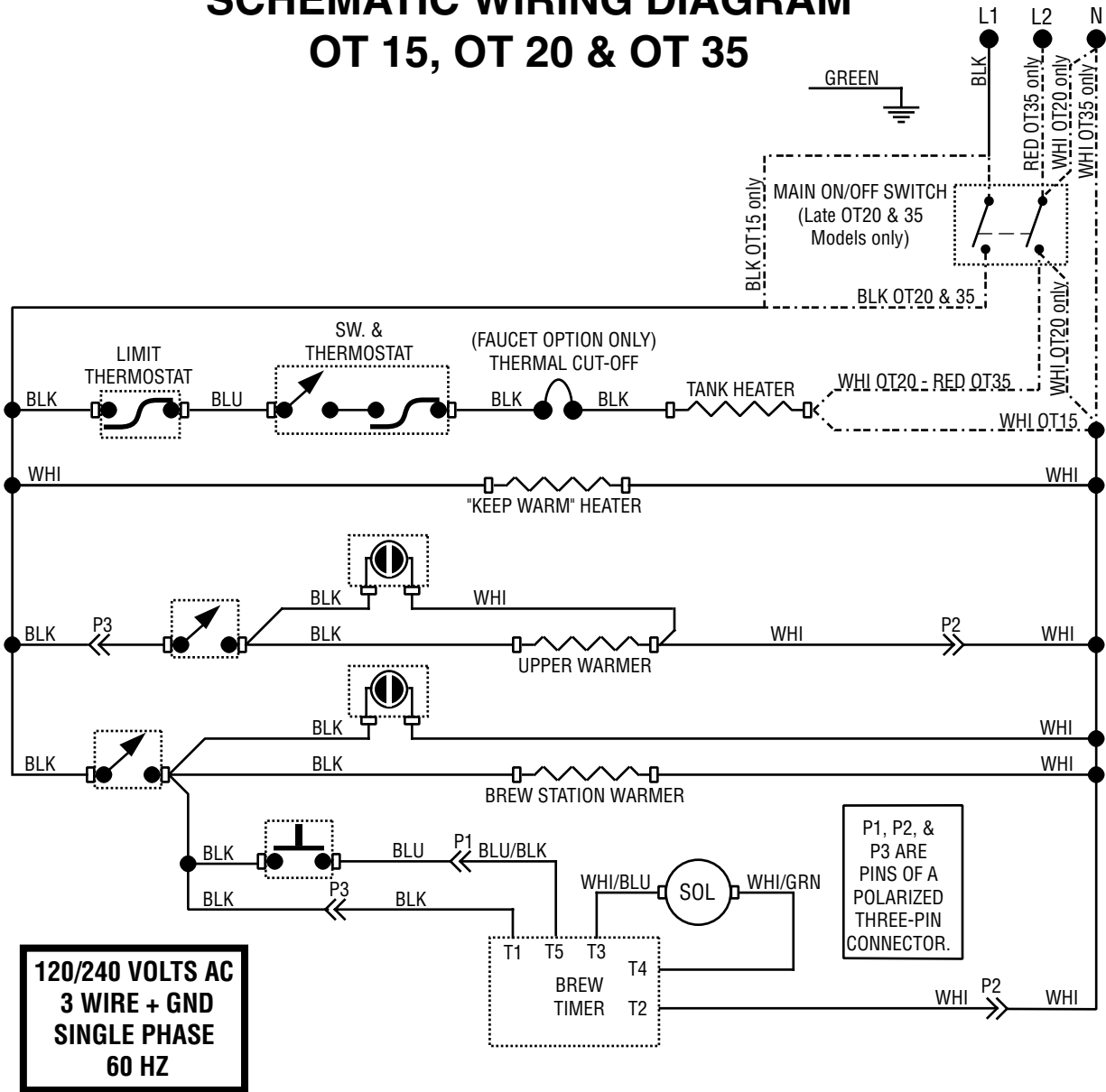
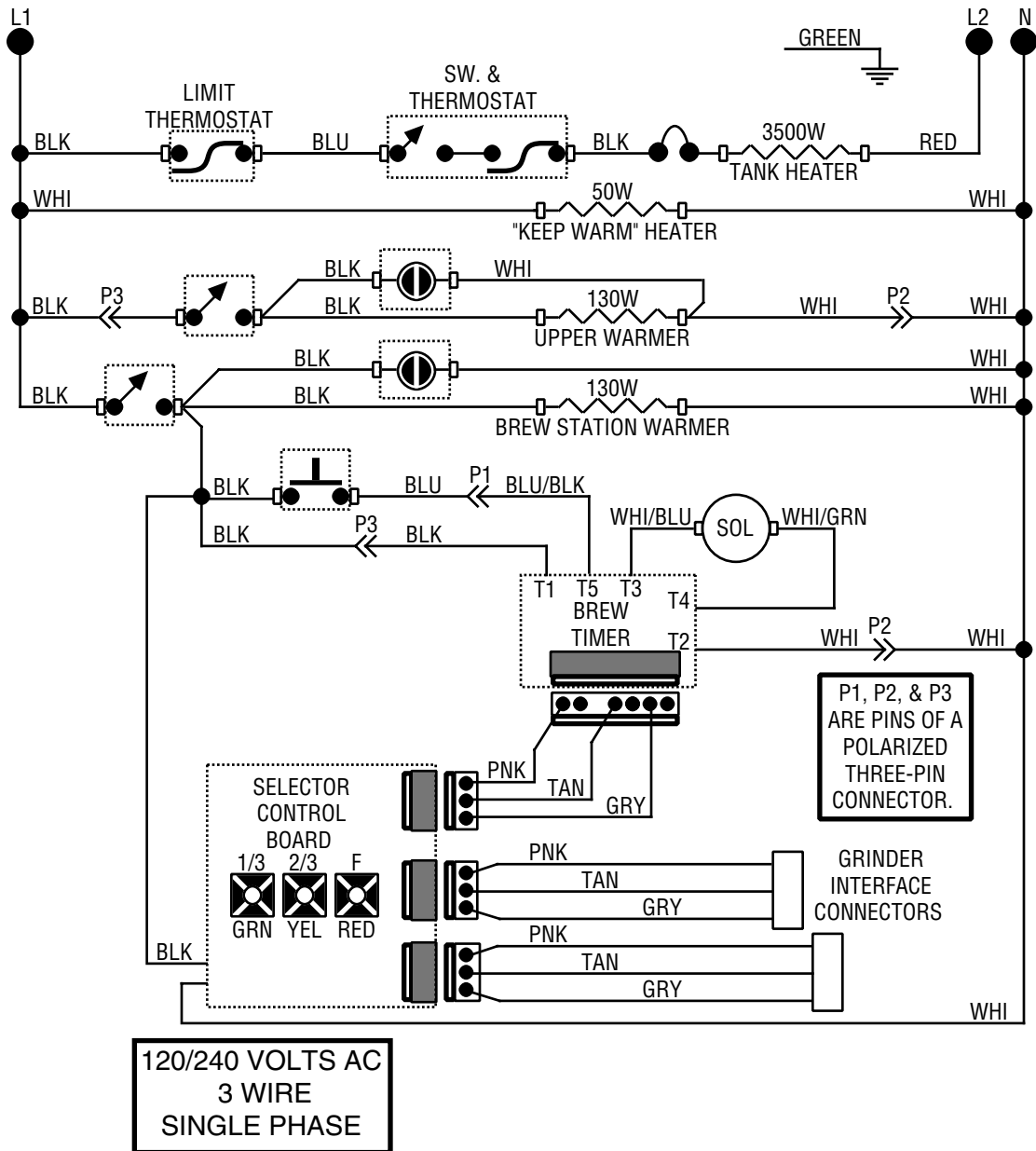

FIG. 31 MASTER ON/OFF SWITCH WIRING

# SCHEMATIC WIRING DIAGRAM OT 15, OT 20 & OT 35



# SCHEMATIC WIRING DIAGRAM OT



# SCHEMATIC WIRING DIAGRAM OTA

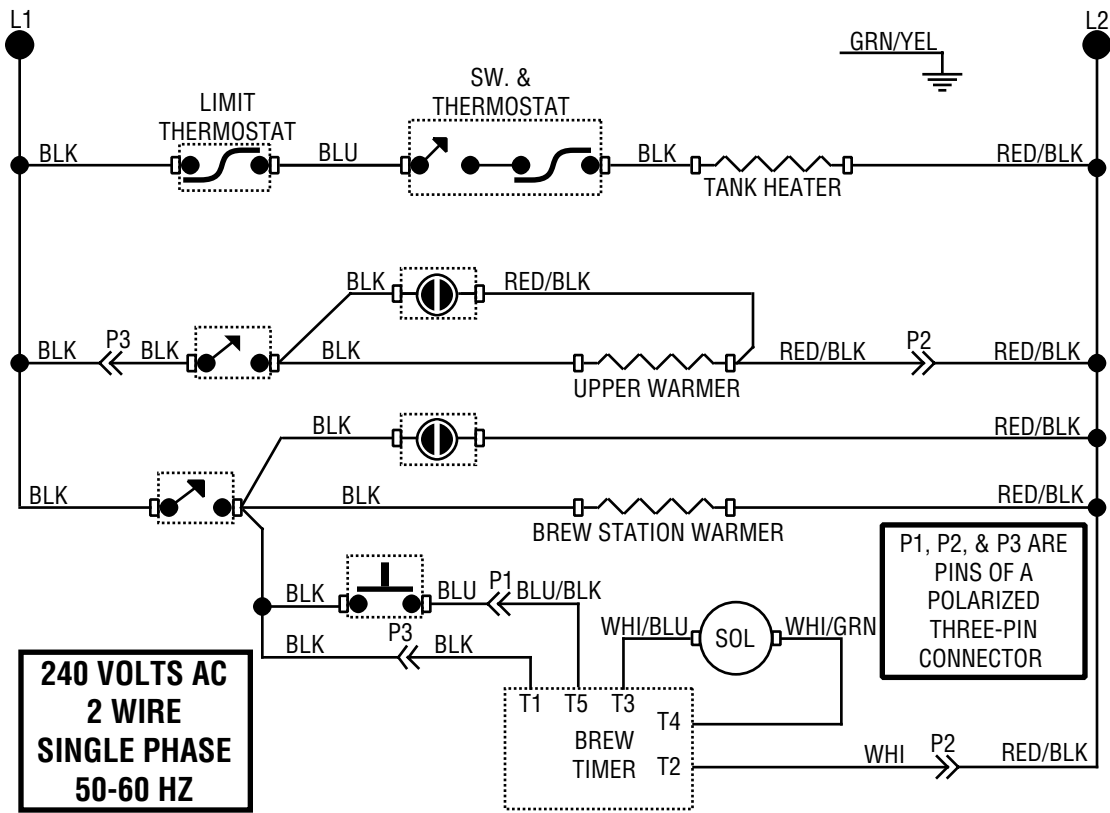

# SCHEMATIC WIRING DIAGRAM OT25B

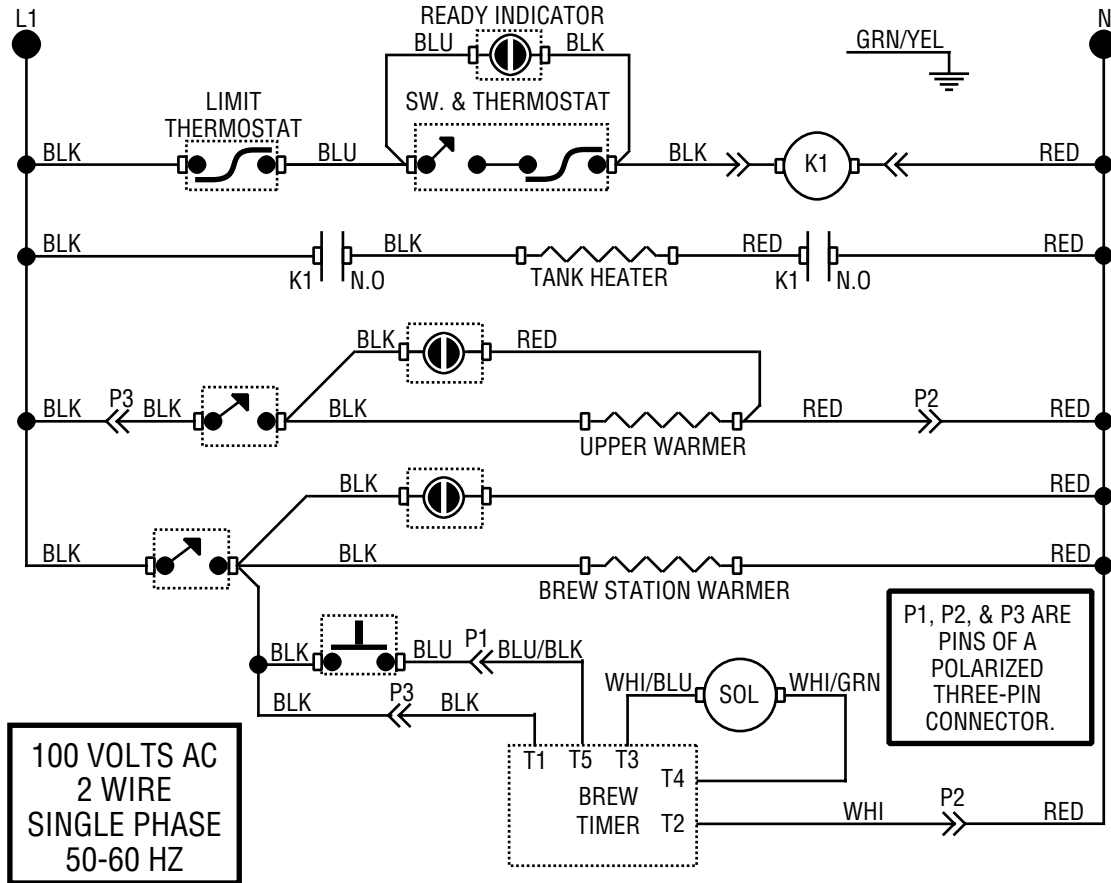

# SCHEMATIC WIRING DIAGRAM OT35B

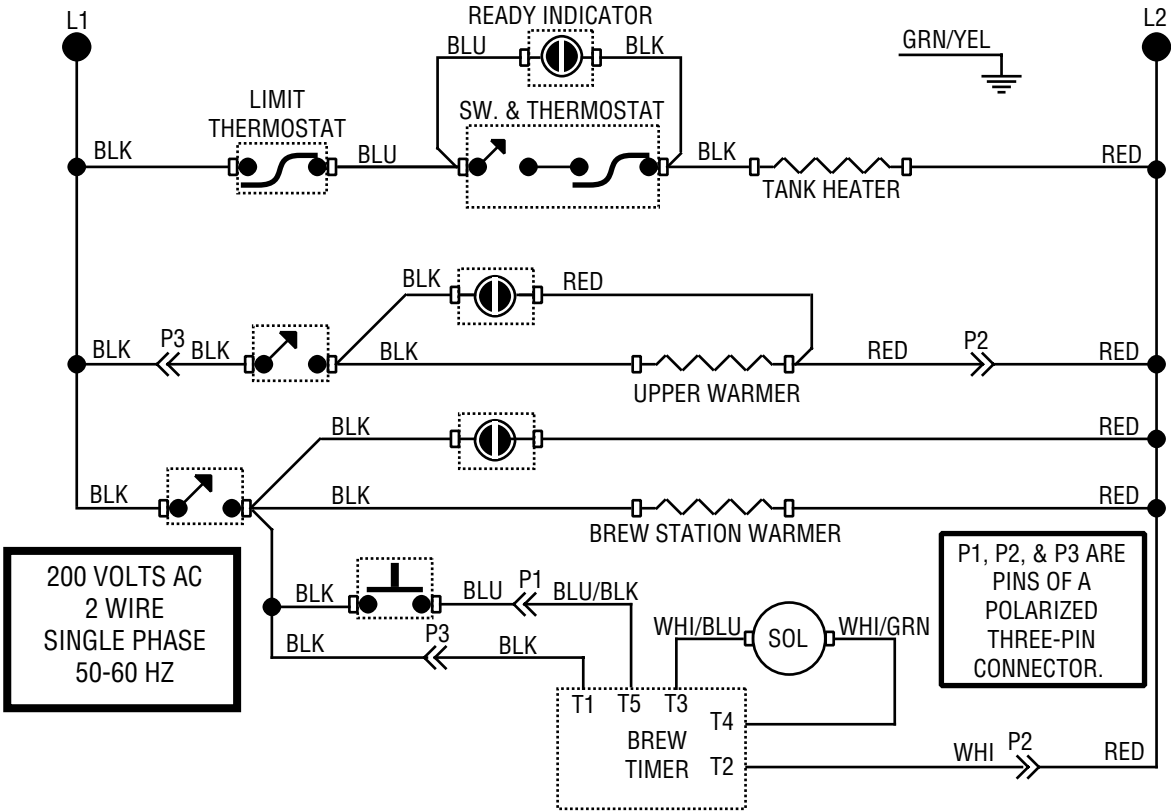



# SCHEMATIC WIRING DIAGRAM RT

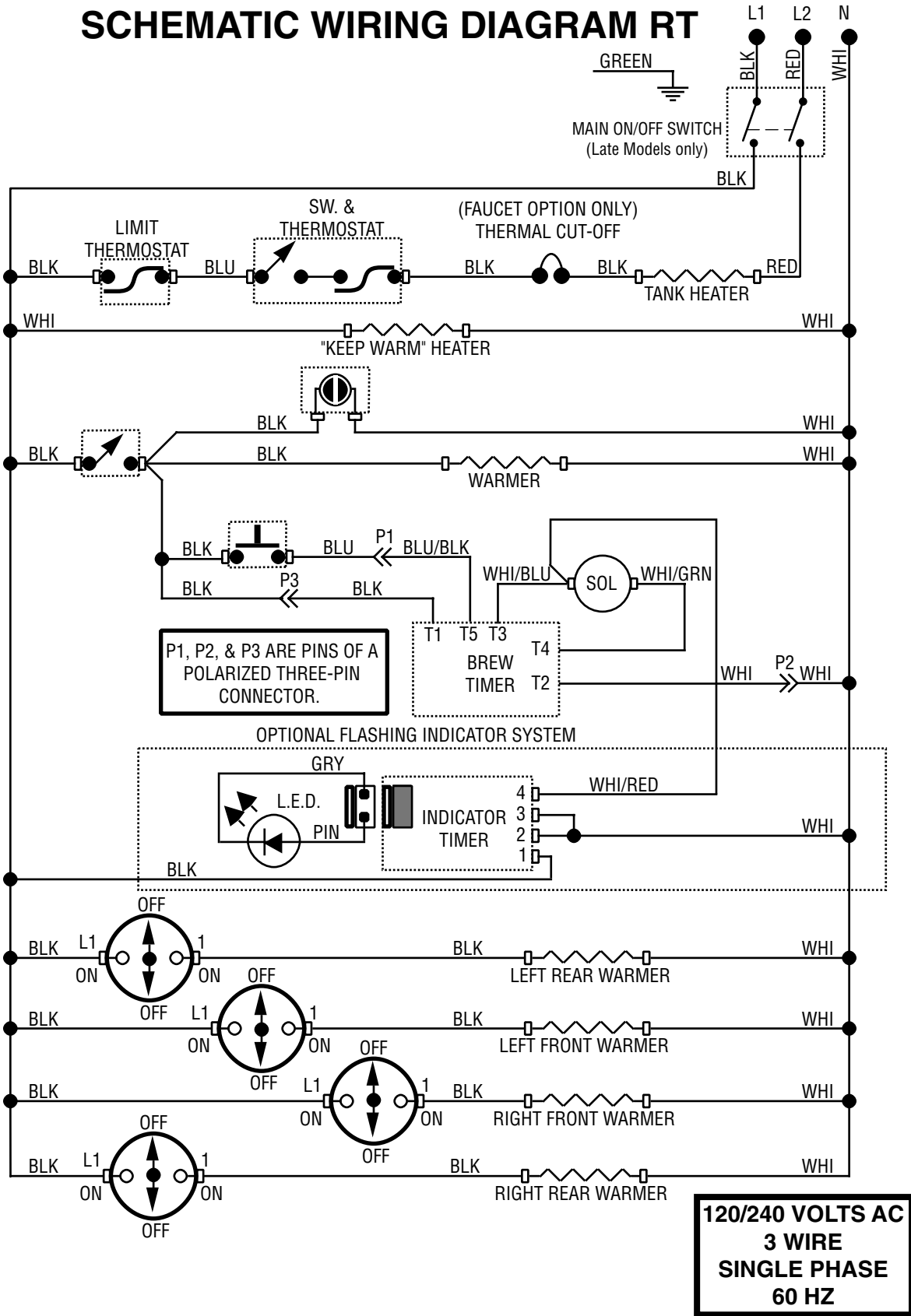

# SCHEMATIC WIRING DIAGRAM RTA

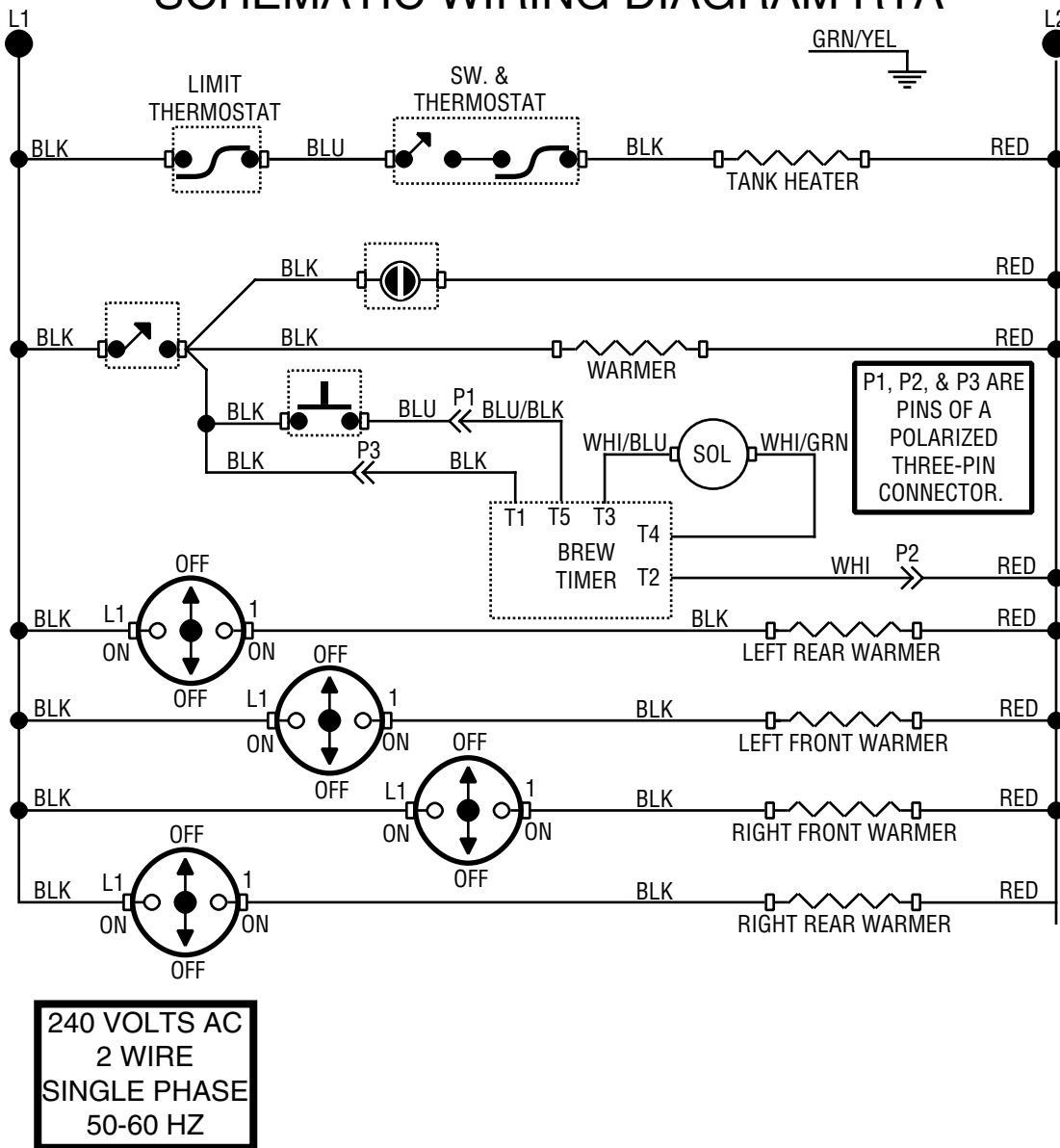

# SCHEMATIC WIRING DIAGRAM RT

