

# BUNN®

## *SINGLE™ TF*

*1.75 GALLON*

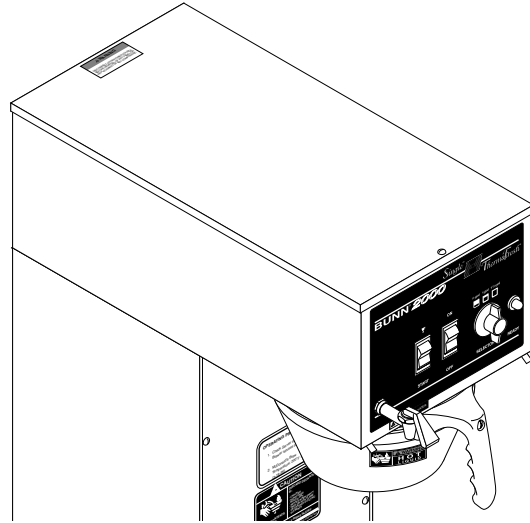

**DISCONTINUED VERSION**  
The information in this manual  
is no longer current.

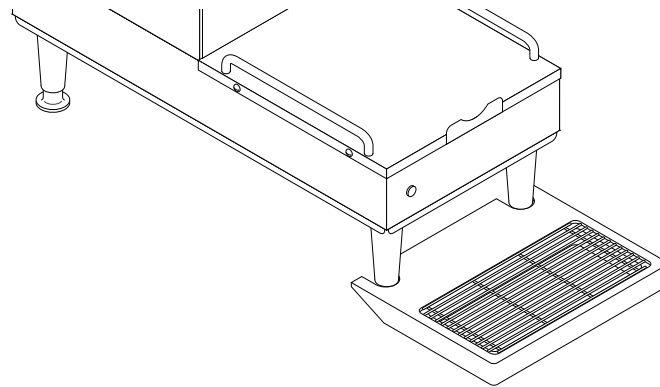

## **OPERATING & SERVICE MANUAL**

### **BUNN-O-MATIC CORPORATION**

**POST OFFICE BOX 3227**

**SPRINGFIELD, ILLINOIS 62708-3227**

**PHONE: (217) 529-6601 FAX: (217) 529-6644**

## INTRODUCTION

This equipment will brew a half-gallon, gallon, or gallon and a three fourths batch of coffee into an awaiting server at the push of a button and includes a hot water faucet for allied beverage use. The brewer is specifically designed for use with a BUNN® .5 gallon and 1.75 gallon server. It is only for indoor use on a sturdy counter or shelf.

## WARRANTY

Bunn-O-Matic Corp. (“Bunn”) warrants the equipment manufactured by it to be commercially free from defects in material and workmanship existing at the time of manufacture and appearing within one year from the date of installation. In addition:

1.) Bunn warrants electronic circuit and/or control boards to be commercially free from defects in material and workmanship for two years from the date of installation.

2.) Bunn warrants the compressor on refrigeration equipment to be commercially free from defects in material and workmanship for two years from the date of installation.

3.) Bunn warrants that the grinding burrs on coffee grinding equipment will grind coffee to meet original factory screen sieve analysis for three years from date of installation or for 30,000 pounds of coffee, whichever comes first.

This warranty does not apply to any equipment, component or part that was not manufactured by Bunn or that, in Bunn’s judgement, has been affected by misuse, neglect, alteration, improper installation or operation, improper maintenance or repair, damage or casualty.

**THE FOREGOING WARRANTY IS EXCLUSIVE AND IS IN LIEU OF ANY OTHER WARRANTY, WRITTEN OR ORAL, EXPRESS OR IMPLIED, INCLUDING, BUT NOT LIMITED TO, ANY IMPLIED WARRANTY OF EITHER MERCHANTABILITY OR FITNESS FOR A PARTICULAR PURPOSE.** The agents, dealers or employees of Bunn are not authorized to make modifications to this warranty or to make additional warranties that are binding on Bunn. Accordingly, statements by such individuals, whether oral or written, do not constitute warranties and should not be relied upon.

The Buyer shall give Bunn prompt notice of any claim to be made under this warranty by telephone at (217) 529-6601 or by writing to Post Office Box 3227, Springfield, Illinois, 62708-3227. If requested by Bunn, the Buyer shall ship the defective equipment prepaid to an authorized Bunn service location. If Bunn determines, in its sole discretion, that the equipment does not conform to the warranty, Bunn shall repair the equipment with no charge for parts during the warranty period and no charge for labor by a Bunn Authorized Service Representative during the warranty period. If Bunn determines that repair is not feasible, Bunn shall, at its sole option, replace the equipment or refund the purchase price for the equipment.

**THE BUYER’S REMEDY AGAINST BUNN FOR THE BREACH OF ANY OBLIGATION ARISING OUT OF THE SALE OF THIS EQUIPMENT, WHETHER DERIVED FROM WARRANTY OR OTHERWISE, SHALL BE LIMITED, AS SPECIFIED HEREIN, TO REPAIR OR, AT BUNN’S SOLE OPTION, REPLACEMENT OR REFUND.**

In no event shall Bunn be liable for any other damage or loss, including, but not limited to, lost profits, lost sales, loss of use of equipment, claims of Buyer’s customers, cost of capital, cost of down time, cost of substitute equipment, facilities or services, or any other special, incidental or consequential damages.

## USER NOTICES

The notices on this brewer should be kept in good condition. Replace unreadable or damaged labels.



00658.0000



20201.5600

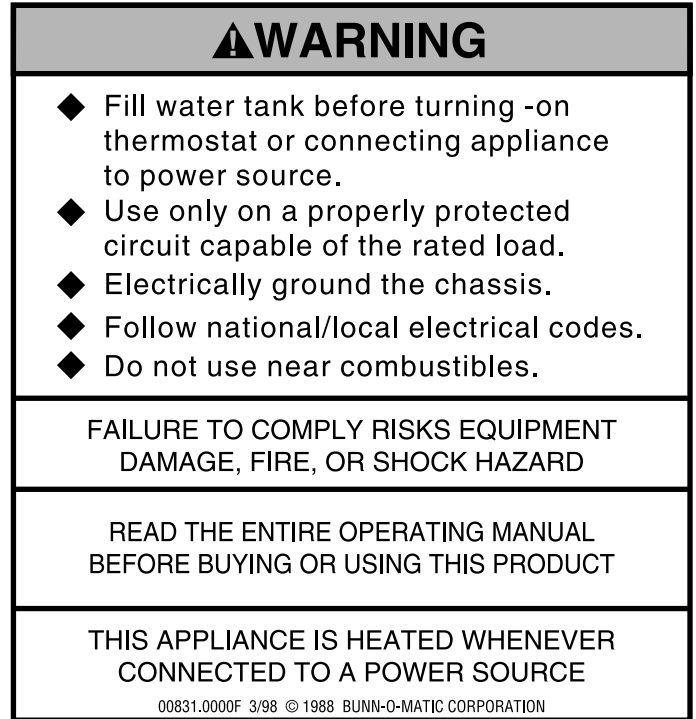

00831.0000

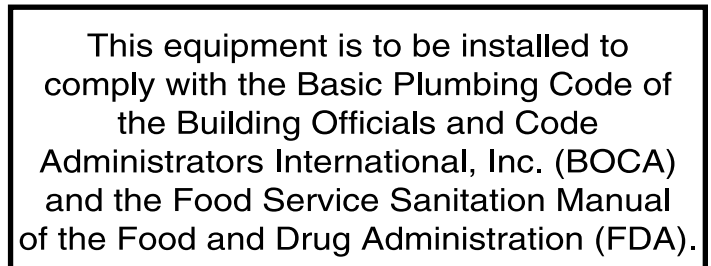

00656.0000

## ELECTRICAL REQUIREMENTS

**CAUTION** - The brewer must be disconnected from the power source until specified in *Initial Set-Up*.

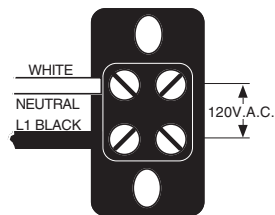

Requires 2-wire, grounded service rated 120 volts ac, 20 amp, single phase, 60 Hz.

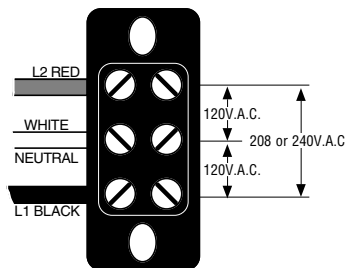

Requires 3-wire, grounded service rated 120/208 volts or 120/240 volts ac, 20 amp, single phase, 60 Hz.

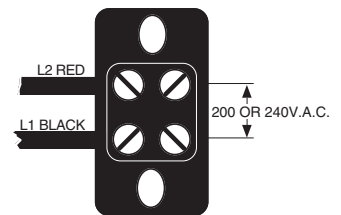

"A" & "B" models require 2-wire, grounded service rated 200 volts ac, 20 amp, single phase, 50 Hz.

## Electrical Hook-Up

**CAUTION** – Improper electrical installation will damage electronic components.

1. An electrician must provide electrical service as specified.
2. Using a voltmeter, check the voltage and color coding of each conductor at the electrical source.
3. Remove the front panel beneath the sprayhead.

### **Models with electronic control assemblies:**

Place the tank heater switch at the top of the control assembly in the “OFF” position.

### **Models with electro/mechanical thermostats:**

Rotate the control thermostat knob fully counterclockwise to the “OFF” position.

4. Feed the cord through the strain relief and connect it to the terminal block.
5. Connect the brewer to the power source and verify the voltage at the terminal block before proceeding. Replace the front panel.
6. If plumbing is to be hooked-up later be sure the brewer is disconnected from the power source. If plumbing has been hooked-up, the brewer is ready for Initial Set-Up.

## PLUMBING REQUIREMENTS

This brewer must be connected to a cold water system with operating pressure between 20 and 90 psi (138 and 620 kPa) from a ½" or larger supply line. A shut-off valve should be installed in the line before the brewer. Install a regulator in the line when pressure is greater than 90 psi (620 kPa) to reduce it to 50 psi (345 kPa). The water inlet fitting is ¼" flare.

**NOTE** – Bunn-O-Matic recommends ¼" copper tubing for installations of less than 25 feet and ⅜" for more than 25 feet from the ½" water supply line. A tight coil of copper tubing in the water line will facilitate moving the brewer to clean the countertop. Bunn-O-Matic does not recommend the use of a saddle valve to install the brewer. The size and shape of the hole made in the supply line by this type of device may restrict water flow.

**This equipment must be installed to comply with the Basic Plumbing Code of the Building Officials and Code Administrators International, Inc. (BOCA) and the Food Service Sanitation Manual of the Food and Drug Administration (FDA).**

## Plumbing Hook-Up

1. Attach the quickconnect fitting from the tubing (supplied) to the water inlet fitting on the bottom of the brewer.
2. Flush the water line and securely attach it to the flare fitting on the tubing (supplied).
3. Turn on the water supply.

## INITIAL SET-UP

**CAUTION** – The brewer must be disconnected from the power source throughout the initial set-up, except when specified in the instructions.

**NOTE:** ECA Models Only - This brewer is equipped with a temperature sensor that indicates when to brew and, when selected, locks-out the start of a brew cycle until the water has heated to the optimum brewing temperature.

1. Remove the front panel beneath the sprayhead.

**Models with electronic control assemblies:**

Place the tank heater switch at the top of the control assembly in the “OFF” position.

**Models with electro/mechanical thermostats:**

Rotate the control thermostat knob fully counterclockwise to the “OFF” position.

2. Connect the brewer to the power source. Water will begin flowing into the tank.
3. When water stops flowing into the tank, remove the front panel and proceed as directed:

**Models with electronic control assemblies:**

Place the tank heater switch at the top of the control assembly in the “ON” position and replace the front panel.

**Models with electro/mechanical thermostats:**

Rotate the control thermostat knob fully clockwise to the “ON” position and replace the front panel.

4. Wait approximately twenty-five minutes on 208V, 240V Models or fifty minutes on 120V Models for the water in the tank to heat to the proper temperature.
5. Place an empty server beneath the brew station. Place the Selector switch in the desired position, the On/Off switch in the upper position and initiate a brew cycle
6. Place the On/Off switch in the lower “OFF” position after water has stopped flowing from the funnel, and check the water volume in the server. It should be 64 oz - 1/2 gallon, 128 oz - 1 gallon or 224 oz - 1-3/4 gallon.

**NOTE:** Brewer will not operate if the server size does not match the selected batch size.

7. (A) If not, disconnect the brewer from the power source, remove the front panel, and adjust the timer as required. Refer to Adjusting Brew Volumes. Replace the front panel, connect the brewer to the power source, allow the water to reheat, start, and measure another brew cycle.  
(B) If necessary adjust the needle valve to achieve water volume to be bypassed around the coffee filter in the funnel.

**NOTE:** To increase the water bypass turn the needle valve counterclockwise, to decrease the water bypass turn the needle valve clockwise. An adjustment to the needle valve will require a timer adjustment for volume.

8. Repeat step 7 until the proper water volume is achieved.
9. The brewer is now ready for use in accordance with the coffee brewing instructions.

## ADJUSTING BREW VOLUMES

**CAUTION** - Disconnect the power source from the brewer prior to the removal of any panel for the replacement or adjustment of any component.

**NOTE:** Prior to setting or modifying batch sizes, check that the brewer is connected to water supply, the tank is properly filled, and a funnel and server are in place.

1. **Modifying batch sizes.** To modify a batch volume, first check that the SET/LOCK switch is in the “SET” position on the circuit board.

**To increase a batch size.** Press and hold the START or BREW switch until three clicks are heard. Release the switch (Failure to release the switch within two seconds after the third click causes the volume setting to be aborted and previous volume setting will remain in memory) and press it again one or more times. Each time the switch is pressed, two seconds are added to the brew time period. Allow the brew cycle to finish in order to verify that the desired volume has been achieved.

**To decrease a batch size.** Press and release the START or BREW switch once for every two-second interval to be removed from the total brew time period; then immediately press and hold down the START or BREW switch until three clicks are heard. Release the switch. (Failure to release the switch within two seconds after the third click causes the volume setting to be aborted and previous volume setting will remain in memory). Allow the brew cycle to finish in order to verify that the desired volume has been achieved.

2. **Setting batch sizes.** To set a batch volume, first check that the SET/LOCK switch is in the “SET” position on the circuit board. Press and hold the START or BREW switch until three distinct clicks are heard, and then release the switch. (Failure to release the switch within two seconds after the third click causes the volume setting to be aborted and previous volume setting will remain in memory). View the level of the liquid being dispensed. When the desired level is reached, turn the ON/OFF switch to “OFF” (lower). The brewer remembers this volume and will continue to brew batches of this size until the volume setting procedure is repeated.

**NOTE:** When brewing coffee, batch volumes will decrease due to absorption by the coffee grounds.

3. **Setting programming disable feature.** If it becomes necessary to prevent anyone from changing brew times once programmed, you can set the SET/LOCK switch to the “LOCK” position. This will prevent any programming to be done until switch is once again placed in the “SET” position.

## **OPERATING CONTROLS**

### **BREW SELECTOR SWITCH**

Placing the switch in the ½ Gal, 1 Gal, or 1¾ Gal position selects the amount of coffee to be brewed in subsequent brew cycles. Repositioning this switch after a brew cycle has been initiated does not change the brew batch in progress.

### **ON/OFF SWITCH**

Placing the switch in the unlighted lower position cuts power to the server sensor and stops brewing. Stopping a brew cycle after it has been started will not stop the flow of water from the funnel. Placing the switch in the lighted upper position supplies power to the server sensor and enables the brew circuit.

### **START SWITCH**

Momentarily pressing and releasing this switch starts a brew cycle when the On/Off switch is in the lighted upper position.

**NOTE:** The On/Off switch must be in the lighted upper position to initiate and complete a brew cycle.

## **COFFEE BREWING**

1. Select the desired batch size.
2. Insert a BUNN® filter into the funnel.
3. Pour the proper amount of fresh coffee into the filter and level the bed of grounds by gently shaking.
4. Slide the funnel into the funnel rails.
5. Place an empty server under the funnel. Make sure server size agrees with batch selection.
6. Place the On/Off switch in the lighted upper position. Momentarily press and release the start switch.
7. When brewing is completed, simply discard the grounds and filter.

## **CLEANING**

1. The use of a damp cloth rinsed in any mild, non-abrasive, liquid detergent is recommended for cleaning all surfaces on Bunn-O-Matic equipment.
2. Check and clean the sprayhead. The sprayhead holes must always remain open.

**NOTE** – In hard water areas, this may need to be done daily. It will help prevent liming problems in the brewer and takes less than a minute.

## TROUBLESHOOTING

A troubleshooting guide is provided to suggest probable causes and remedies for the most likely problems encountered. If the problem remains after exhausting the troubleshooting steps, contact the Bunn-O-Matic Technical Service Department.

- Inspection, testing, and repair of electrical equipment should be performed only by qualified service personnel.
- All electronic components have 120 - 240 volt ac and low voltage dc potential on their terminals. Shorting of terminals or the application of external voltages may result in board failure.
- Intermittent operation of electronic circuit boards is unlikely. Board failure will normally be permanent. If an intermittent condition is encountered, the cause will likely be a switch contact or a loose connection at a terminal or crimp.
- Solenoid removal requires interrupting the water supply to the valve. Damage may result if solenoids are energized for more than ten minutes without a supply of water.
- The use of two wrenches is recommended whenever plumbing fittings are tightened or loosened. This will help avoid twists and kinks in the tubing.
- Make certain that all plumbing connections are sealed and electrical connections tight and isolated.
- This brewer is heated at all times. Keep away from combustibles.

### WARNING

- Exercise extreme caution when servicing electrical equipment.
- Disconnect power source when servicing, except when electrical tests are specified.
- Follow recommended service procedures.
- Replace all protective shields or safety notices.

Problem	Probable Cause	Remedy
Equipment will not operate. Brew cycle will not start.	1. No power or incorrect voltage	(A1) Check the terminal block for 120 volts across the black and white terminals on 120 volt two wire brewers. (A2) Check the terminal block for 120 volts across the red and white terminals and the black and white terminals on 120/208 or 120/240 volt brewers. (A3) Check the terminal block for 200 volts on "B Series" brewers or 240 volts on "A Series" brewers across the red and black terminals.  (B) Check circuit breakers or fuses.
Brew cycle will not start.	1. Server  2. No water	Make sure server size agrees with batch selection.  Check plumbing and shut-off valves



## TROUBLESHOOTING (cont.)

<b>Problem</b>	<b>Probable Cause</b>	<b>Remedy</b>	
Brew cycle will not start (cont.)	3. Water strainer/flow control (.500 GPM)	(A) Direction of flow arrow must be pointing towards brewer.  (B) Remove the strainer/flow control and check for obstructions. Clear or replace.	
	4. ON/OFF switch	Refer to <i>Service</i> - ON/OFF switch for testing procedures. See page 31	
	5. Start switch	Refer to <i>Service</i> - Start switch for testing procedures. See page 35	
	6. Timer	Refer to <i>Service</i> - Timer for testing procedures. See page 38 or 40	
	7. Dispense Valve	Refer to <i>Service</i> - Dispense valve for testing procedures. See page 22	
	8. Control Assembly (Electronic)	Refer to <i>Service</i> - Electronic controls for testing procedures. See pages 23 thru 27	
	9. Brew selector switch	Refer to <i>Service</i> - Brew selector switch for testing procedures. See page 16	
	10. Server sensor	Refer to <i>Service</i> - Server sensor for testing procedures. See page 33	
	Automatic refill will not operate	1. No water	Check plumbing and shut-off valves.
		2. Water strainer/flow control (.500 GPM)	(A) Direction of flow arrow must be pointing towards brewer.  (B) Remove the strainer/flow control and check for obstructions. Clear or replace.

## TROUBLESHOOTING (cont.)

Problem	Probable Cause	Remedy
Automatic refill will not operate (cont.)	3. Overflow protection switch	Refer to <i>Service</i> - Overflow protection switch for testing procedures. See page 32
	4. (A) Level control board & level probe. (Electro/mechanical)	Refer to <i>Service</i> -Level control board for testing procedures. See page 28
	(B) Control Assembly (Electronic)	Refer to <i>Service</i> - Electronic controls for testing procedures. See page 23 thru 27
	5. Solenoid Valve	Refer to <i>Service</i> - Solenoid valve for testing procedures. See page 34
Beverage level will not adjust (Selector switch in any position)	1. Selector switch	Refer to <i>Service</i> - Selector switch for testing procedures. See page 16
Water flows into tank continuously (ON/OFF Switch "ON")	1. Timer	Refer to <i>Service</i> - Timer for testing procedures. See page 38 or 40
Water flows into tank continuously (ON/OFF Switch "OFF")	1. (A) Level control board and level probe (Electro/mechanical)	Refer to <i>Service</i> - Level control board for test procedures. See page 28
	(B) Control assembly (Electronic)	Refer to <i>Service</i> - Control assembly for testing procedures. See page 23 thru 27
	2. Overflow protection switch	Refer to <i>Service</i> - Overflow protection switch for testing procedures. See page 32
	3. Solenoid Valve	Refer to <i>Service</i> - Solenoid valve for testing procedures. See page 34
Water from tank is not hot	1. Limit thermostat <b>CAUTION</b> - Do not eliminate or bypass limit thermostat. Use only B.O.M. part #23717.0001	Refer to <i>Service</i> -Limit thermostat for testing procedures. See page 30

## TROUBLESHOOTING (cont.)

Problem	Probable Cause	Remedy
Water from tank is not hot (cont.)	2. (A) Control Thermostat (Electro/mechanical)	Refer to <i>Service</i> - Control thermostat for testing procedures. See page 20
	(B) Control assembly (Electronic)	Refer to <i>Service</i> - Control assembly for testing procedure. See page 23 thru 27
	3. Contactor (Electro/mechanical)	Refer to <i>Service</i> - Contactor for test procedures. See page 18
	4. Tank heater	Refer to <i>Service</i> - Tank heater for testing procedures. See page 36
	5. Triac assembly (Electronic)	Refer to <i>Service</i> - Triac assembly for removal and replacement. See page 27
Spitting or unusual steaming from sprayhead or airvent.	1. (A) Control thermostat (Electro/mechanical)	Refer to <i>Service</i> - Control thermostat for testing procedures. See page 20
	(B) Control assembly (Electronic)	Refer to <i>Service</i> - Control assembly for testing procedures. See page 23 thru 27
	2. Triac assembly (Electronic)	Refer to <i>Service</i> - Triac assembly for testing procedures. See page 27
	3. Lime build-up <b>CAUTION</b> - Tank and tank components should be delimed regularly depending on local water conditions. Excessive mineral build-up on stainless steel surfaces can initiate corrosive reactions resulting in serious leaks.	Inspect the tank assembly for excessive lime deposits. Delime as required.

## TROUBLESHOOTING (cont.)

<b>Problem</b>	<b>Probable Cause</b>	<b>Remedy</b>
Inconsistent beverage level in server.	1. Strainer/flow control (.500 GPM)	(A) Direction of flow arrow must be pointing towards the brewer.  (B) Remove the strainer/flow control and check for obstructions. Clear or replace.
	2. Improper water pressure	Check the operating water pressure to the brewer. It must be between 20 and 90 psi (138 and 620 kPa)
	3. Dispense valve	Refer to <i>Service</i> - Dispense valve for testing procedures. See page 22
Consistently high or low beverage level in server.	1. Timer adjustment	Adjust the timer as required to achieve the recommended volume for each brew cycle.
Dripping from sprayhead.	1. Dispense valve	Refer to <i>Service</i> - Dispense valve for testing procedures. See page 22
Water overflows filter.	1. Bypass valve	Refer to <i>Adjustments</i> on page 5 step #7. For test procedures see page 15
	2. Type of paper filters	BUNN® paper filters should be used for proper extraction.
	3. No sprayhead	Check sprayhead
Beverage overflows server.	1. Beverage left in server	The brew cycle should be started only with an empty server under the funnel.
	2. Timer adjustment	Adjust the timer as required to achieve the recommended 224 oz for each 1-3/4 gallon brew cycle. Refer to <i>Service</i> - Timer for testing procedures. See page 38 or 40
	3. Dispense valve	Refer to <i>Service</i> - Dispense valve for testing procedures. See page 22

## TROUBLESHOOTING (cont.)

<b>Problem</b>	<b>Probable Cause</b>	<b>Remedy</b>
Weak beverage	1. Type of paper filters	BUNN® paper filters should be used for proper extraction.
	2. Coffee	A sufficient quantity of fresh drip or regular grind should be used for proper extraction.
	3. Sprayhead	B.O.M. sprayhead #01082.0002 should be used to properly wet the bed of ground coffee in the funnel.
	4. Funnel loading	The BUNN® paper filter should be centered in the funnel and the bed of ground coffee leveled by gentle shaking.
	5. Water temperature	Empty the server, remove its cover. Place empty funnel over the server entrance, with ON/OFF switch in the "ON" position press the start switch and release it. Check the water temperature immediately below the sprayhead with a thermometer. The reading should not be less than 195° F.
Brewer is making unusual noises.	1. Solenoid (Inlet)	The nut on back of the solenoid must be tight or it will vibrate during operation
	2. Plumbing lines	Plumbing lines should not be resting on the counter top.
	3. Water supply	(A) The brewer must be connected to a cold water line.  (B) Water pressure to the brewer must not be higher than 90 psi (620 kPa). Install a regulator if necessary to lower the working pressure to approximately 50 psi (345 kPa).
	4. Tank heater	Remove and clean lime off the tank heater.
	5. Contactor	Check for low voltage.

## SERVICE

This section provides procedures for testing and replacing various major components used in this brewer should service become necessary. Refer to *Troubleshooting* for assistance in determining the cause of any problem.

**WARNING** - Inspection, testing, and repair of electrical equipment should be performed only by qualified service personnel. The brewer should be unplugged when servicing, except when electrical tests are required and the test procedure specifically states to plug-in the brewer.

### COMPONENT ACCESS

**WARNING** - Disconnect the brewer from the power source before the removal of any panel or the replacement of any component.

All components are accessible by the removal of the top cover, front inspection panel and warmer base plate.

The top cover is attached with one #4-40 slotted head screw.

The front inspection panel is attached with four #6-32 slotted head screws.

The server platform is attached with seven #6-32 slotted head screws.

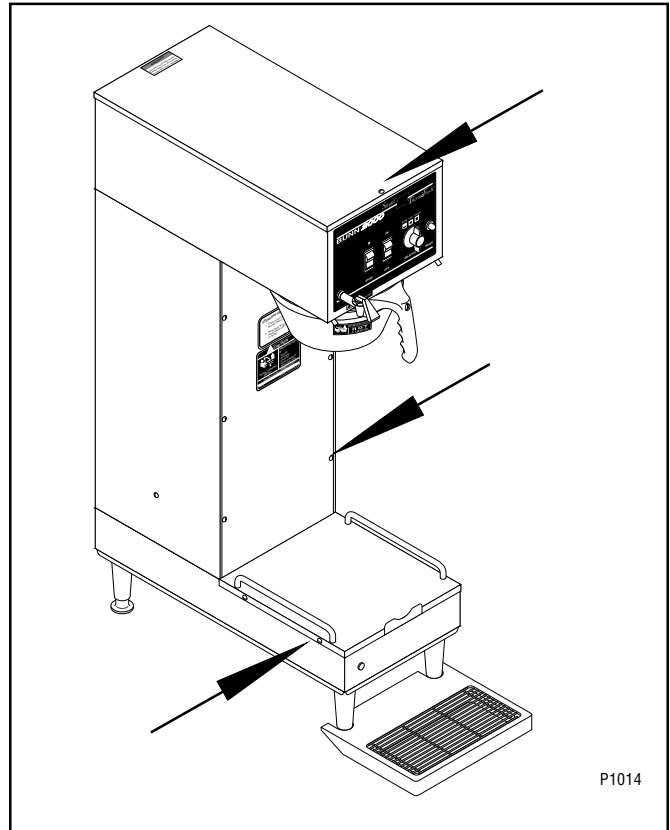

### Contents

Brewer Selector Switch .....	16
Bypass Valve .....	15
Contactor Assembly .....	18
Control Thermostat .....	20
Dispense Valve .....	22
Electronic Control .....	23 thru 27
Level Control Board and Level Probe .....	28
Limit Thermostat .....	30
ON/OFF Switch .....	31
Overflow Protection Switch .....	32
Proximity Sensor .....	33
Solenoid (Inlet) .....	34
Start Switch (Brew) .....	35
Tank Heater .....	36
Timer .....	38,40
Wiring Diagrams .....	42 thru 45

## SERVICE (cont.)

### BYPASS VALVE

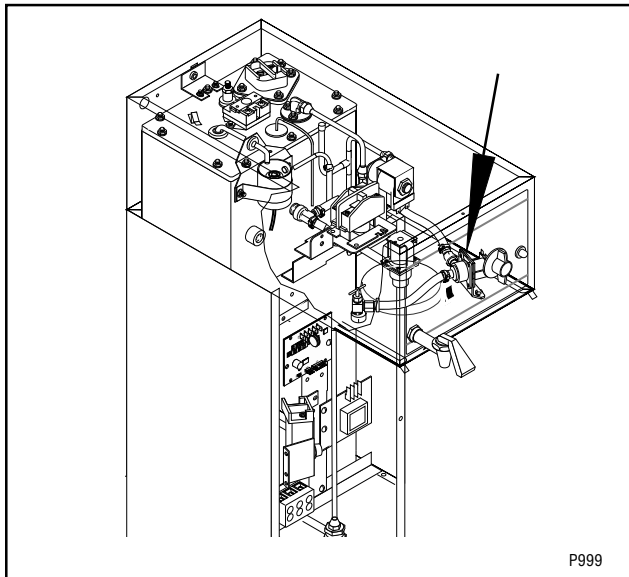

#### Location:

The bypass valve is located inside the right front of the hood.

#### Test Procedures:

1. Disconnect the brewer from the power source and place a 1-3/4 gallon server under funnel.
2. Disconnect the white/green wire and the white/violet wire from the bypass valve.

**NOTE:** ECA MODELS ONLY - Brewer must be at operating temperature to perform step #3 or brew-lock must be bypassed. To bypass brew-lock disconnect white/yellow and orange wires from interlock of ECA and connect harness leads together.

3. Check the voltage across the white/green and the white/violet wires with a voltmeter. Connect the brewer to the power source. With the "ON/OFF" switch in the "ON" position, the selector switch in the 1 or 1-3/4 gallon position press the start switch. The indication must be:
  - a.) 120 volts ac for two wire 120 volt models, three wire 120/208 volt models and three wire 120/240 volt models.
  - b.) 200 to 240 volts ac for two wire 200 or 240 volt models.
4. Disconnect the brewer from the power source.

If voltage is present as described, proceed to #5.

If voltage is not present as described refer to the wiring

diagrams and check the brewer wiring harness.

5. Check for continuity across the bypass valve coil terminals.

If continuity is present as described, reconnect the white/green and white/violet wires to the bypass valve, brew-lock wires if necessary and proceed to #6.

If continuity is not present as described, replace the bypass valve.

6. Check the bypass valve for coil action. Connect brewer to the power source. With the ON/OFF" switch in the "ON" position press the start switch. Listen carefully in the vicinity of the by-pass valve for a "clicking" sound as the coil attracts and repels the plunger.

If the sound is heard as described, there may be a blockage in the water line before the bypass valve or the bypass valve may require inspection for wear and removal of waterborne particles.

If the sound is not heard as described, replace the bypass valve.

#### Removal and Replacement:

1. Remove the wires from the bypass valve.
2. Drain enough water from the tank so bypass valve is above the water line.
3. Remove water lines from valve.
4. Remove two nuts retaining bypass valve inside the hood and remove bypass valve.
5. Remove hose barb fitting and attach to new bypass valve.
6. Install new bypass valve with hose barb fitting.
7. Reconnect the water tubes and the wires to the bypass valve.
8. Refer to the illustration below when reconnecting the wires.

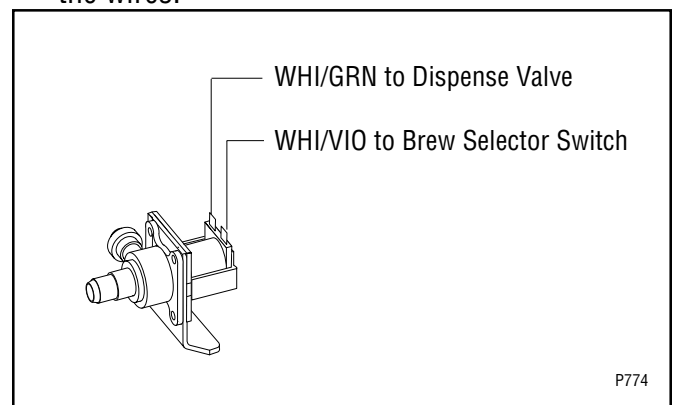

## SERVICE (cont.)

### BREW SELECTOR SWITCH

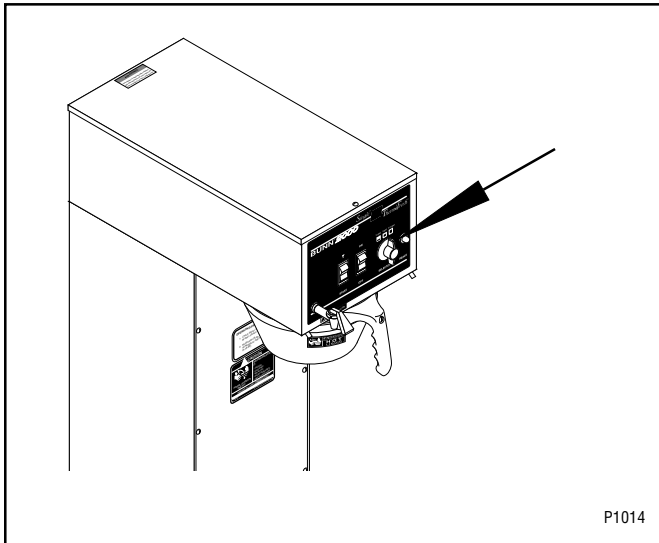

#### Location:

The brew selector switch is located in the front right side of the hood.

#### Test Procedure:

##### Timer:

1. Disconnect the brewer from the power supply.
2. Separate the connector on the selector switch harness from the brew timer circuit board.
3. Carefully slide the plastic cover off of the connector from the switch harness.
4. Check for continuity across the pink and tan wires on the connector when the switch is in the 1/2 gallon position. Continuity must not be present in any other switch position.
5. Check for continuity across the pink wire and gray wire when the switch is in the 1 gallon position. Continuity must not be present in any other position.
6. Reattach the connector to the brew timer circuit board.

##### Grinder Interface:

7. Disconnect the pink, gray and tan wires on the selector switch from the pink, gray and tan wires on the interface socket.
8. Check for continuity across the pink wire and tan wire on the selector switch when the switch is in the 1/2 gallon position. Continuity must not be present in any other position.

9. Check for continuity across the pink wire and gray wire on the selector switch when the switch is in the 1 gallon position. Continuity must not be present in any other position.
10. Reconnect the pink, gray and tan wires on the selector switch to the pink, gray and tan wires on the interface.

##### Bypass Valve:

11. Disconnect the white/violet on the selector switch from the bypass valve coil and disconnect the white/red from the dispense valve coil.
12. Check for continuity across the white/violet and the white red wires when the selector switch is in the 1 gallon and 1-3/4 gallon position. Continuity must not be present in any other position.
13. Reconnect the white/violet to the bypass valve coil and the white/red to the dispense valve coil.

##### Server Sensor:

14. Disconnect the yellow, white/orange and the orange wires of the selector switch from the yellow, white/orange and orange wires of the brewer wiring harness.
15. Check for continuity across the white/orange and yellow wires on the selector switch when the switch is in the 1/2 gallon position. Continuity must not be present in any other position.
16. Check for continuity across the white/orange and orange wires on the selector switch when the switch is in the 1 gallon and 1-3/4 gallon position. Continuity must not be present in any other position.
17. Reconnect the yellow, white/orange and orange wires.

If continuity is present as described the switch is operating properly.

If continuity is not present as described, replace the switch.

##### Removal and Replacement:

1. Disconnect the connector on the selector switch harness from the brewer timer circuit board.
2. Disconnect wires from the selector switch, interface socket, dispense valve, bypass valve and proximity sensor harness.
3. Loosen the set screw on the switch knob.
4. Remove the 9/16" nut and washer holding the switch to the hood.



## SERVICE (cont.)

### BREW SELECTOR SWITCH (cont.)

5. Remove the switch.
6. Install the new switch. The positioning tab must be in the hole in the hood for proper switch and knob alignment.
7. Install the knob so that the arrow lines-up in the 1-3/4 gallon position when the switch is turned to the full right position.

8. Reattach the connector to the brew timer circuit board.
9. Refer to the illustration below when reconnecting the wires.

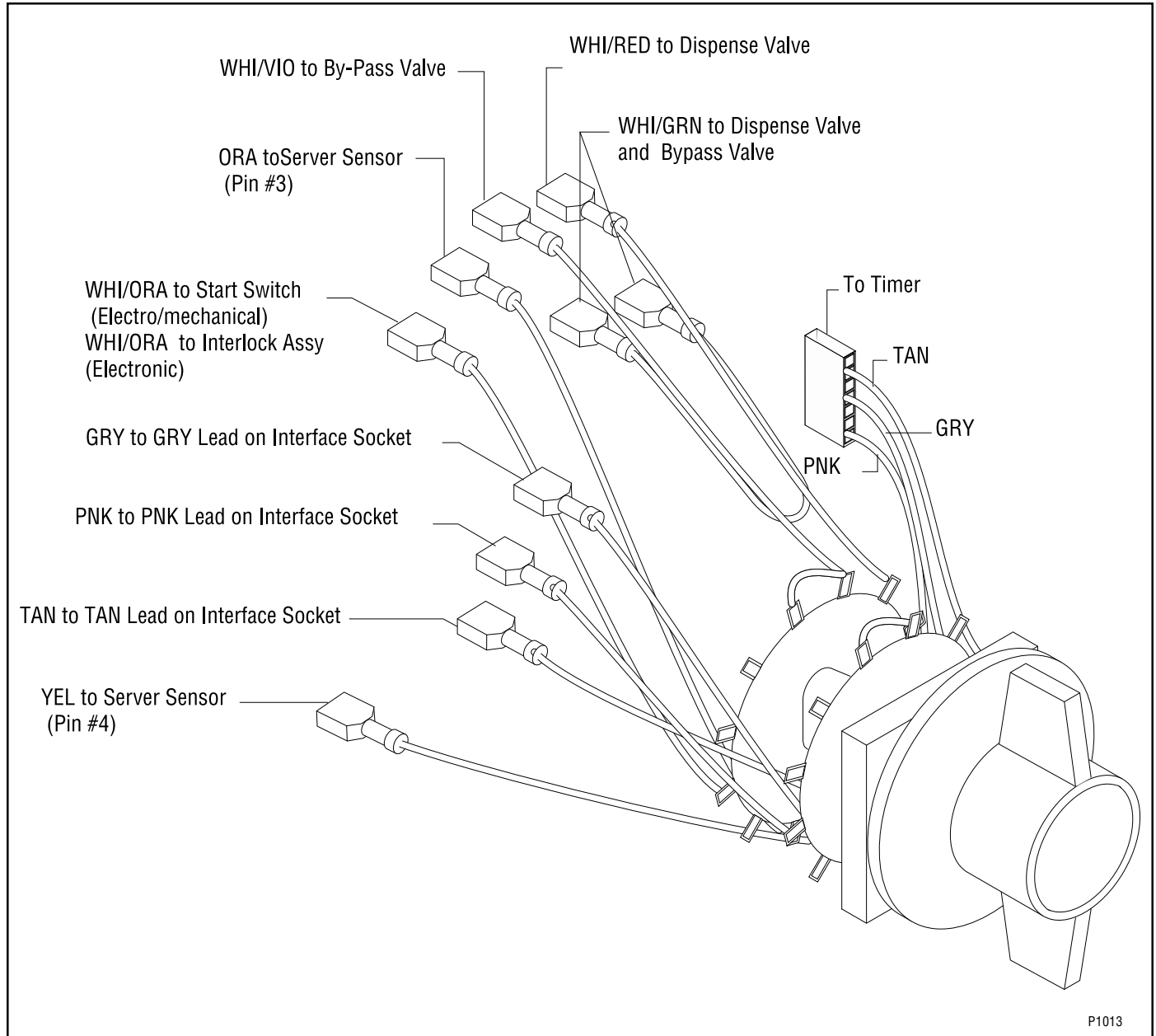

## SERVICE (cont.)

### CONTACTOR ASSEMBLY (W/MECHANICAL THERMOSTAT ONLY)

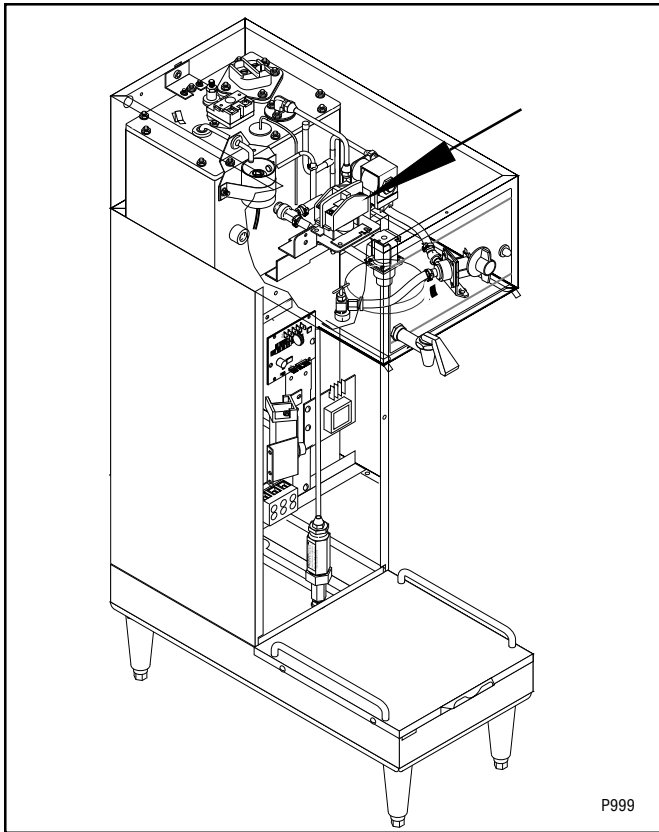

#### Location:

The contactor assembly is located inside the hood just behind the dispense valve.

#### Test Procedures:

##### Mechanical Thermostat

1. Disconnect the brewer from the power source.
2. Disconnect the white wire of the two pole 120V terminal block, white wire of the three pole 120/208V or 120/240V or the red wire of the two pole 200V or 240V terminal block and the black wire of the contactor coil and disconnect the black wire of the control thermostat from the remaining black wire of the contactor coil.
3. Gently remove the capillary bulb and grommet from the tank.
4. Check the voltage across the white wire from the terminal block on 120, 120/208, 120/240 volt units or the red wire from 200, 240 volt units and the black wire from the control thermostat with a voltmeter when the thermostat is turned clockwise to the "FULL ON" position. Connect the brewer to the power source. The indication must be:

a.) 120 volts ac for two wire 120 volt models, three wire 120/208 volt models and three wire 120/240 volt models.

b.) 200 to 240 volts ac for two wire 200 or 240 volt models.

5. Disconnect the brewer from the power source.

If voltage is present as described, proceed to #6.

If voltage is not present as described, refer to the wiring diagrams and check the brewer wiring harness.

6. Check for continuity between the two black wires of the contactor coil.

If continuity is present as described, reconnect one black wire to the white wire or red wire from the terminal block and the other black wire to the black wire from the control thermostat. Reinstall capillary tube into tank to line 7" above the bulb and proceed to #7.

If continuity is not present as described, replace the contactor.

7. Locate the white wire or red wire on L1 terminal and black wire on the L2 terminal on the contactor.

8. Carefully check the voltage across the white or red and black wires with a voltmeter. The indication must be:

a.) 120 volts ac for two wire 120 volt models, 208 volts ac for three wire 120/208 volt models and 240 volts ac for three wire 20/240 volt models.

b.) 200 to 240 volts ac for two wire 200 or 240 volt models.

9. Disconnect the brewer from the power source.

If voltage is present as described, proceed to #10.

If voltage is not present as described, refer to the wiring diagrams and check the brewer wiring harness.

10. Check for continuity across the terminals on the left side of the contactor by manually closing the contacts. Continuity must not be present when the contact is released.

11. Check for continuity across the terminals on the right side of the contactor by manually closing the contacts. Continuity must not be present when the contact is released.

## SERVICE (cont.)

### CONTACTOR ASSEMBLY (W/ MECHANICAL THERMOSTAT ONLY) (cont.)

If continuity is present as described, the contactor is operating properly.

If continuity is not present as described, replace the contactor.

#### Removal and Replacement:

1. Remove all wires from the contactor.
2. Remove the two #10-32 slotted head screw securing contactor to the inside of the hood.
3. Securely install the new contactor inside the hood.
4. Refer to the illustration below when reconnecting the wires.

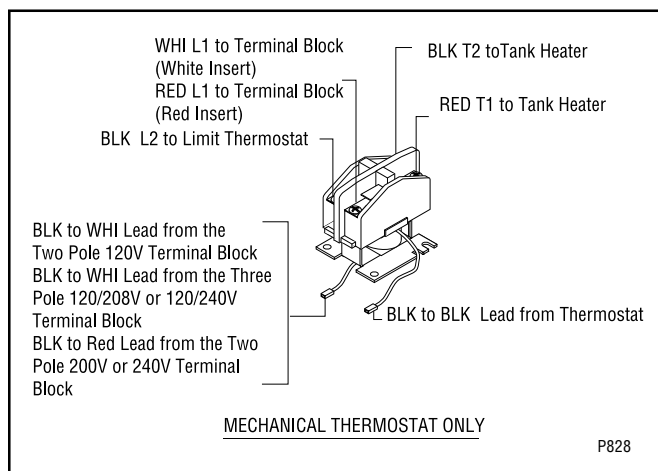

## SERVICE (cont.)

### CONTROL THERMOSTAT

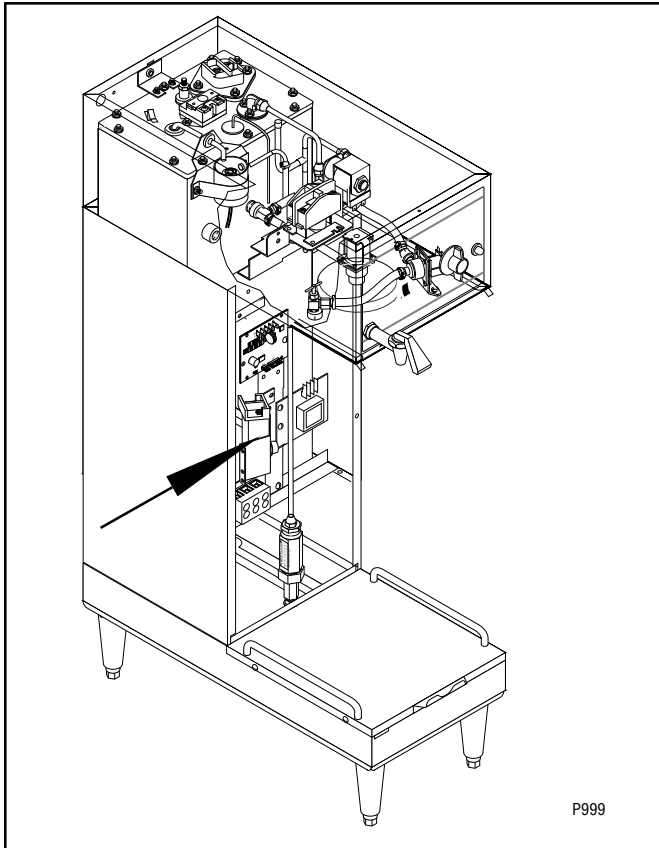

#### Location:

The control thermostat is located inside the lower left front of the brewer on the component bracket.

1. Disconnect the brewer from the power source.
2. Locate the blue wires on the control thermostat.
3. Check the voltage across the blue wires on the control thermostat and the white insert on the two or three pole 120V, 120/208V, 120/240V terminal block and the red insert on two pole 200V or 240V terminal blocks with a voltmeter. Connect the brewer to the power source. The indication must be:
  - a.) 120 volts ac for two wire 120 volt models, three wire 120/208 volt models and three wire 120/240 volt models.
  - b.) 200 to 240 volts ac for two wire 200 or 240 volt models.
4. Disconnect the brewer from the power source.

If voltage is present as described, reconnect the wire and proceed to #5.

If voltage is not present as described, refer to the wiring diagrams and check the brewer wiring harness

5. Locate the black wires on the control thermostat.
6. Gently remove the capillary bulb and grommet from the tank.
7. Check the voltage across the black wires of the control thermostat and the white insert on the two pole or three pole 120V, 120/208V or 120/240V terminal blocks and the red insert on two pole 200V/240V terminal blocks with a voltmeter when the control thermostat is turned "ON" (fully clockwise). Connect the brewer to the power source. The indication must be:
  - a.) 120 volts ac for two wire 120 volt models, three wire 120/208 volt models and three wire 120/240 volt models.
  - b.) 200 to 240 volts ac for two wire 200 or 240 volt models.Voltage must not be indicated across these terminals when the thermostat is turned "OFF" (fully counterclockwise).
8. Disconnect the brewer from the power source.

If voltage is present as described, reinstall the capillary tube into the tank to the line 7" above the bulb, the control thermostat is operating properly.

If voltage is not present as described, replace the thermostat.

## SERVICE (cont.)

### CONTROL THERMOSTAT (cont.)

#### Removal and Replacement:

1. Remove wires from the control thermostat.
2. Remove the thermostat capillary bulb by firmly pulling-up on the capillary tube at the tank lid. This will disengage the grommet from tank lid.
3. Remove the #8-32 slotted head screw holding the control thermostat to the component bracket.
4. Slide the grommet to the line 7" above the bulb on the new capillary tube.
5. Insert the capillary bulb through the hole in the tank lid and press the grommet firmly and evenly so that the groove in the grommet fits into the tank lid.
6. Carefully bend the capillary tube so that the tube and bulb inside the tank are in the vertical position.

**NOTE** - The capillary tube must be clear of any electrical termination and not kinked.

7. Using a #8-32 slotted head screw fasten the control thermostat to the component bracket.
8. Refer to the illustration below when reconnecting the wires.
9. Adjust the control thermostat as required.

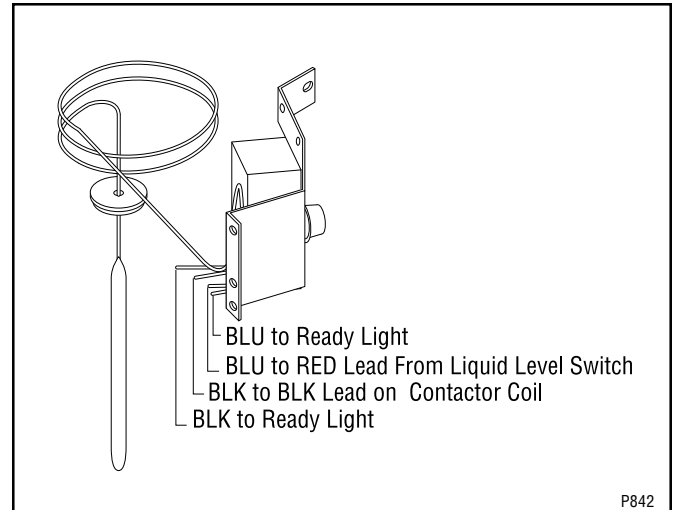

## SERVICE (cont.) DISPENSE VALVE

### Location:

Dispense valve is located inside the hood directly above the sprayhead.

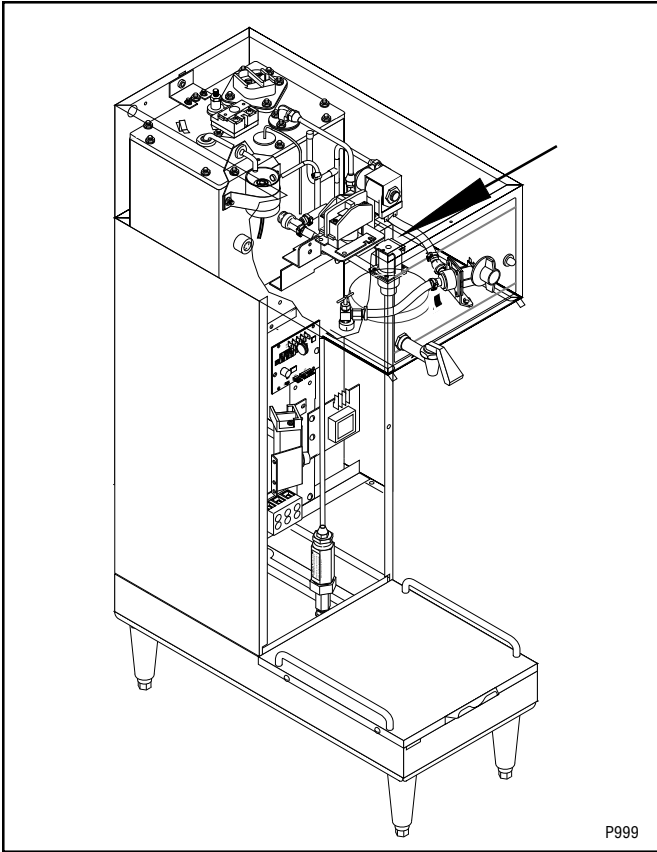

### Test Procedures:

1. Disconnect the brewer from the power source.

**NOTE:** ECA MODELS ONLY - Brewer must be at operating temperature to perform step #2 or brew-lock must be bypassed. To bypass brew-lock disconnect white/yellow and orange wires from interlock of ECA and connect leads together.

2. Disconnect the wires from the dispense valve and check the voltage across the white/violet wire and white/green wire. Connect brewer to the power source. Place the "ON/OFF" switch in the "ON" position, press and release the start switch. The indication must be:

a.) 120 volts ac for two wire 120 volt models, three wire 120/208 volt models and three wire 120/240 volt models.

b.) 200 to 240 volts ac for two wire 200 or 240 volt models.

3. Disconnect brewer from the power source.

If voltage is present as described in step 2 proceed to #4.

If voltage is not present as described, refer to the wiring diagrams and check the brewer wiring harness.

4. Check for continuity across the dispense valve coil terminals.

If continuity is present as described, reconnect the wires to the dispense valve, brew-lock wires if necessary and proceed to #5.

If continuity is not present as described, replace the dispense valve.

5. Check the dispense valve for coil action. Connect the brewer to power source. Place the "ON/OFF" switch in the "ON" position, press and release the start switch. Listen carefully in the vicinity of the dispense valve for a "clicking" sound as the coil magnet attracts and repels the plunger.

6. Disconnect the brewer from the power source.

If the sound is heard as described, there may be a blockage in the dispense valve or the water line to the sprayhead. Remove the dispense valve and inspect for wear, and remove waterborne particles.

If the sound is not heard as described, replace the dispense valve.

### Removal and Replacement:

1. Disconnect wires from dispense valve.
2. Drain enough water from the tank so the dispense valve is above the water line.
3. Remove water lines and hose barb fitting from dispense valve.
4. Remove dispense valve from the sprayhead panel.
5. Install new dispense valve .
6. Reconnect the water lines, hose barb fitting and the wires to the dispense valve.
7. Refer to the illustration below when reconnecting wires.

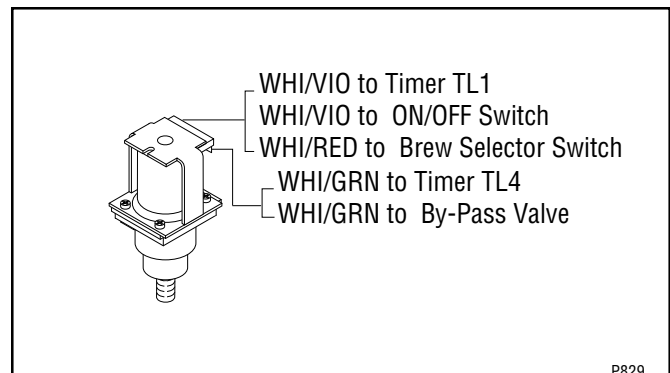

## SERVICE (cont.)

### ELECTRONIC CONTROL ASSEMBLY

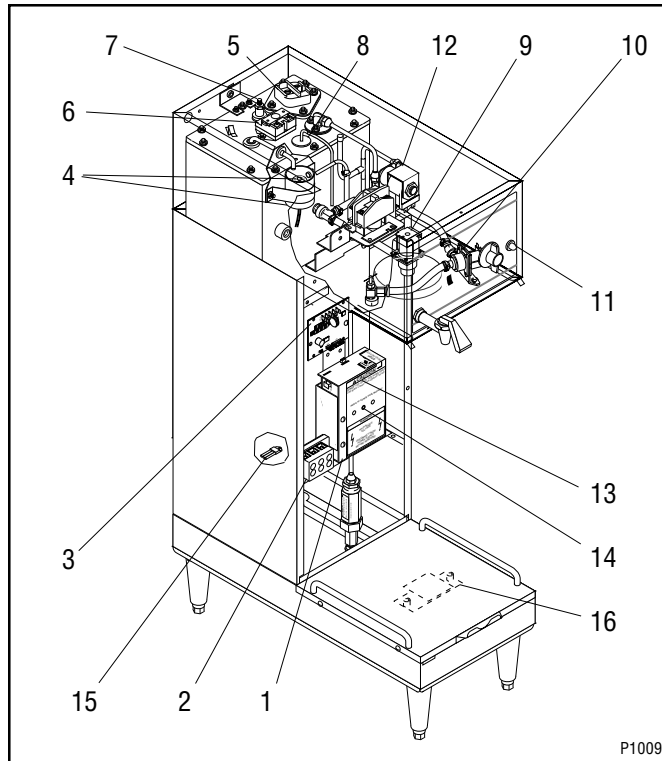

- |                                       |                            |
|---------------------------------------|----------------------------|
| 1. Electronic Control                 | 8. Temperature Sensor      |
| 2. Terminal Block                     | 9. Dispense Valve          |
| 3. Timer                              | 10. Bypass Valve           |
| 4. Liquid Level Switch & Overflow Cup | 11. Ready Light            |
| 5. Tank Heater                        | 12. Solenoid Valve         |
| 6. Limit Thermostat                   | 13. LED                    |
| 7. Liquid Level Probe                 | 14. Temperature Adjustment |
|                                       | 15. Triac Assy             |
|                                       | 16. Server Sensor          |

#### Location:

The electronic control assembly (1) is located inside the lower left front on the component bracket of the brewer. Access will also be needed to the temperature sensor (8), liquid level probe (7) located on the tank lid and to the triac assembly (15) located beneath the tank.

#### General:

This system controls the liquid level and water temperature of the brewer. These two functions act independently of each other and should be tested separately.

#### BREW START - LOCK

The water must be heated to the preset temperature indicated by the glowing ready light before a brew

cycle can be initiated.

If the ready light goes out during a brew cycle, the cycle will continue until it is completed. You must wait until the ready light glows before starting another brew cycle.

#### PROBLEM:

#### LIQUID LEVEL CONTROL SYSTEM DOES NOT REFILL

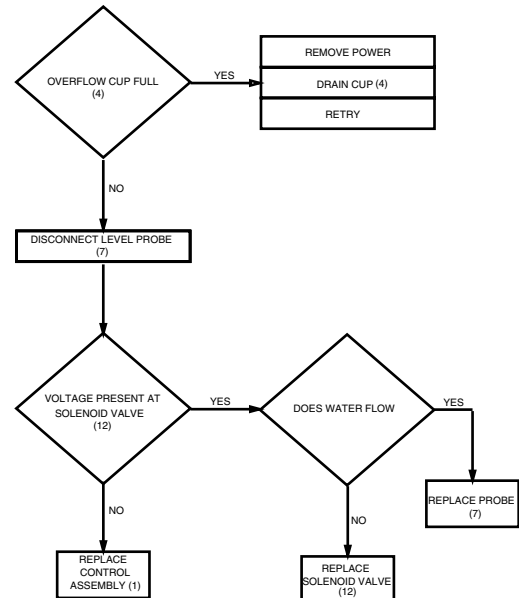

#### Liquid Level Control Test Procedure:

1. Disconnect brewer from the power source.
2. Check the voltage across terminals 3 & 4 of the electronic control assembly (1) with a voltmeter. Connect brewer to power source. The indication must be:
  - a.) 120 volts ac for two wire 120 volt models, 208 volts ac for three wire 120/208 volt models and 240 volts ac for three wire 120/240 volt models.
  - b.) 200 to 240 volts ac for two wire 200 or 240 volt models.
3. Disconnect brewer from the power source.

If voltage was present as described, proceed to #4. If voltage was not present as described, refer to the wiring diagrams and check the brewer wiring harness.

4. Remove the pink wire from terminal 5 of the electronic control assembly (1).
5. Check the voltage across terminals 1 & 4 of the electronic control assembly (1) with a voltmeter. Connect brewer to the power source. The indication must be:
  - a.) 120 volts ac for two wire 120 volt models, three wire 120/208 volt models and three wire

## SERVICE (cont.)

### ELECTRONIC CONTROL ASSEMBLY (cont.)

120/240 volt models after a delay of approximately 1 second.

b.) 200 to 240 volts ac for two wire 200 or 240 volt models after a delay of approximately 1 second.

6. Disconnect the brewer from the power source.

If voltage was present as described, the liquid level control system is operating properly, proceed to #7.

If voltage was not present as described, replace the electronic control assembly (1) and temperature sensor (8) in the tank lid.

**NOTE** - Each electronic control assembly is calibrated to a temperature sensor. Both components **MUST** be replaced as a set.

7. Reconnect the pink wire to terminal 5 of the electronic control assembly (1).

8. Remove the liquid level probe (7) from the tank lid, and inspect it for mineral deposits. Replace it if necessary. Keep the exposed ends of the probe away from any metal surface of the dispenser.

9. Check the voltage across terminals 1 & 4 of the electronic control assembly (1) with a voltmeter. Connect the brewer to the power source. The indication must be:

a.) 120 volts ac for two wire 120 volt models, three wire 120/208 volt models and three wire 120/240 volt models after a delay of approximately 1 second.

b.) 200 to 240 volts ac for two wire 208 or 240 volt models after a delay of approximately 1 second.

10. Touch the screw head end of the probe to the brewer housing. The indication must be 0.

11. Move the probe away from the brewer housing. The indication must again be:

a.) 120 volts ac for two wire 120 volt models, three wire 120/208 volt models and three wire 120/240 volt models after a delay of approximately 1 second.

b.) 200 to 240 volts ac for two wire 200 or 240 volt models after a delay of approximately 1 second.

12. Disconnect the brewer from the power source.

If voltage was present as described, reinstall the probe, the sensing function of the system is operating properly.

If voltage was not present as described, check the pink probe wire and the green ground wire for continuity and/or replace the probe.

### PROBLEM: LIQUID LEVEL CONTROL OVERFLOWS

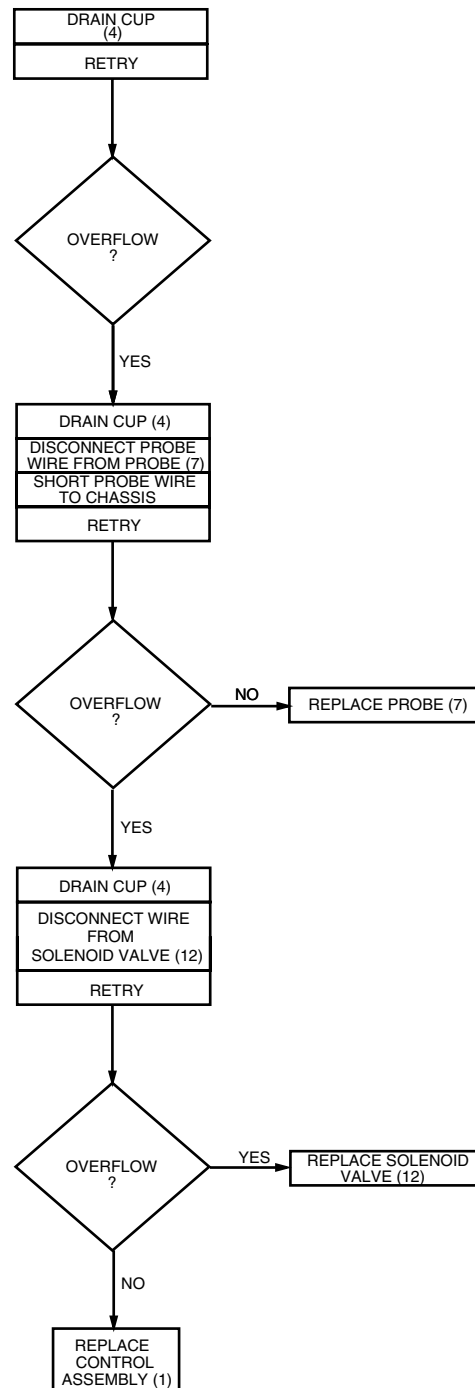



**SERVICE (cont.)  
ELECTRONIC CONTROL ASSEMBLY (cont.)**

**PROBLEM  
WATER NOT HOT ENOUGH**

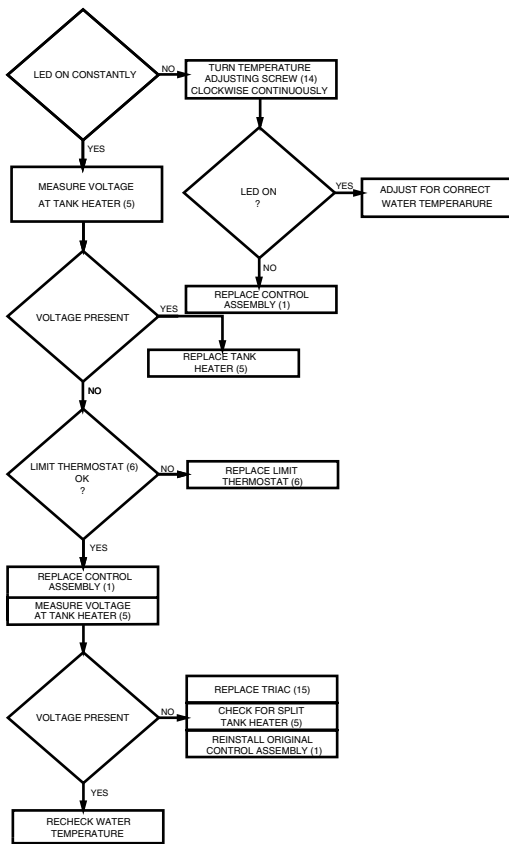

**PROBLEM:  
WATER BOILS**

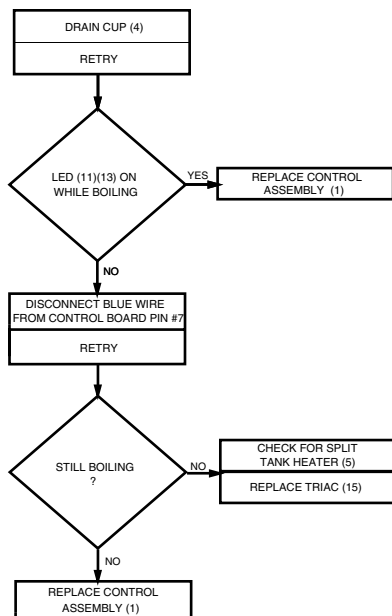

Temperature Control Test Procedure

1. Disconnect the brewer from the power source.
2. Check the voltage across terminals 3 & 4 of the electronic control circuit board with a voltmeter. Connect the brewer to the power source. The indication must be:
  - a.) 120 volts ac for two wire 120 volt models, 208 volts ac for three wire 120/208 volt models and 240 volts ac for three wire 120/240 volt models.
  - b.) 200 to 240 volts ac for two wire 200 or 240 volt models.
3. Disconnect the brewer from the power source.

If voltage was present as described, proceed to #4. If voltage was not present as described, refer to the wiring diagrams and check the brewer wiring harness.

4. Connect the brewer to the power source and place the tank heater switch in the "ON" position.
5. Observe the red LED indicator on the electronic control circuit board (13).
6. Disconnect the brewer from the power source.

If the indicator was on or blinking, the temperature sensor is operating properly, proceed to #7. If the indicator was off, check the sensor connection on the electronic control circuit board and/or replace the temperature sensor (8) and the electronic control assembly (1).

NOTE - each temperature sensor is calibrated to an electronic control assembly. Both components MUST be replaced as a set.

7. Check the voltage across the tank heater (5) terminals with a voltmeter. Connect the brewer to the power source. The indication must be:
  - a.) 120 volts ac for two wire 120 volt models, 208 volts ac for three wire 120/208 volt models and 240 volts ac for three wire 120/240 volt models while the red indicator on the circuit board is on or blinking.
  - b.) 200 to 240 volts ac for two wire 200 or 240 volt models while the red indicator on the circuit board is on or blinking.
8. Disconnect the brewer from the power source.

P844

P845

## SERVICE (cont.)

### ELECTRONIC CONTROL ASSEMBLY (cont.)

If voltage was present as described, the temperature control of the system is operating properly.

If voltage was not present as described, contact Bunn-O-Matic to order an electronic control assembly (1), temperature sensor (8), and triac assembly (15) for reevaluation and proceed to #9.

9. Replace the electronic control assembly (1) and temperature sensor (8).

NOTE - each electronic control assembly is calibrated to a temperature sensor. Both components MUST be replaced as a set.

10. Check the voltage across the tank heater terminals (5) with a voltmeter. Connect the brewer to the power source. The indication must be:
  - a.) 120 volts ac for two wire 120 volt models, 208 volts ac for three wire 120/208 volt models and 240 volts ac for three wire 120/240 volt models while the red indicator on the circuit board is on or blinking.
  - b.) 200 to 240 volts ac for two wire 200 or 240 volt models while the red indicator on the circuit board is on or blinking.
11. Disconnect the brewer from the power source.

If voltage was present as described, return the new triac assembly (15) to Bunn-O-Matic for credit. The temperature control of the system is operating properly.

If voltage was not present as described, reinstall your existing electronic control assembly (1) and temperature sensor (8), and proceed to #12.

12. Replace the triac assembly (15).
13. Check the voltage across the tank heater terminals (5) with a voltmeter. Connect the brewer to the power source. The indication must be:
  - a.) 120 volts ac for two wire 120 volt models, 208 volts ac for three wire 120/208 volt models and 240 volts ac three wire 120/240 volt models while the red indicator on the circuit board is on or blinking.
  - b.) 200 to 240 volts ac for two wire 200 or 240 volt models while the red indicator on the circuit is on or blinking.

14. Disconnect the brewer from the power source.

If voltage was present as described, the temperature control of the system is operating properly. Return the new electronic control assembly (1) and temperature sensor (8) to Bunn-O-Matic for credit.

### Electronic Controls Removal and Replacement

NOTE - each electronic control assembly is calibrated to a temperature sensor. Both components MUST be replaced as a set.

1. Remove all wires from the electronic control assembly terminals.
2. Remove the two 8-32 screws holding the electronic control assembly to the component bracket.
3. Disconnect the temperature sensor and ready indicator wires from the left side of the electronic control assembly board.
4. Remove the temperature sensor from the grommet in the tank lid.
5. Install the new temperature sensor into the grommet on the tank lid. Route the wires to the location of the new electronic control assembly.
6. Attach the temperature sensor and ready indicator wires to the electronic control assembly.
7. Fasten the new electronic control assembly to its bracket.
8. Reconnect the wires.
9. Refer to the illustration on next page when reconnecting the wires.
10. Review the initial set-up procedures and adjust the control as required for the desired temperature.

**SERVICE (cont.)**  
**ELECTRONIC CONTROL ASSEMBLY (cont.)**

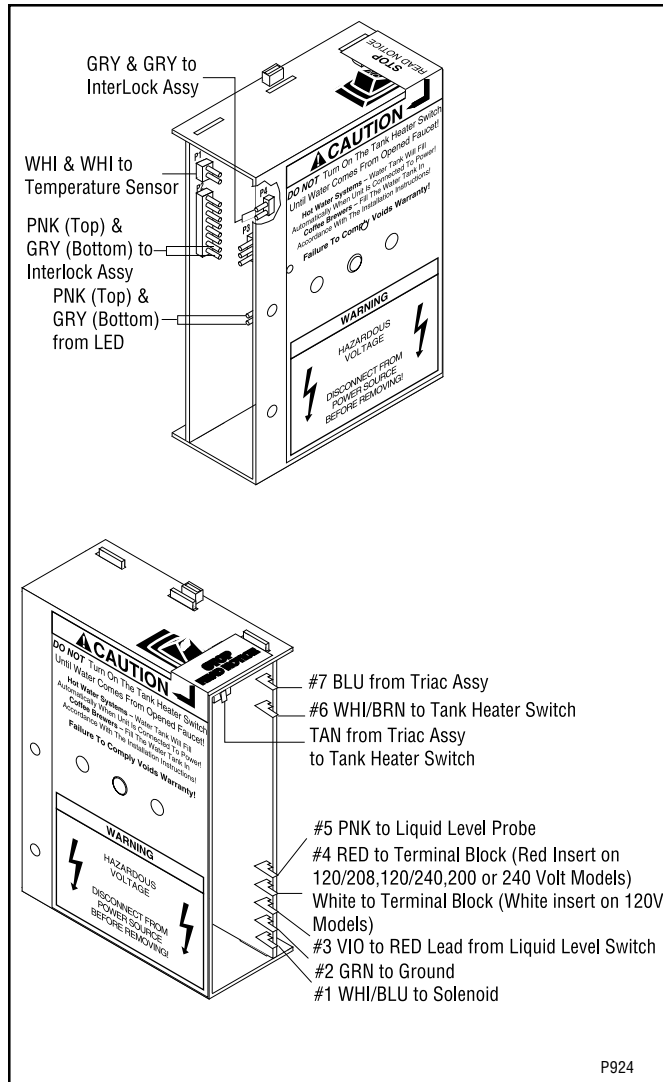

7. Remove the two #8-32 keps nuts securing tank to tank mounting bracket.
8. Remove the twelve #8-32 slotted head screws securing the bottom cover.
9. Remove the bottom cover with the four feet, the tank mounting brackets, triac/heat sink as an assembly.
10. Remove triac/heat sink from tank mounting bracket and discard.
11. Install new triac/heat sink assembly on tank mounting bracket.
12. Route the wires up around the rear of the brewer.
13. Reinstall the bottom cover, four feet, tank mounting brackets and triac/heat sink to the bottom of the tank using two #8-32 keps nuts.
14. Secure bottom cover to brewer base with twelve #8-32 slotted head screws.
15. Stand the brewer upright.
16. Reconnect the wires of the new triac assembly. Refer to the illustration below when reconnecting wires.

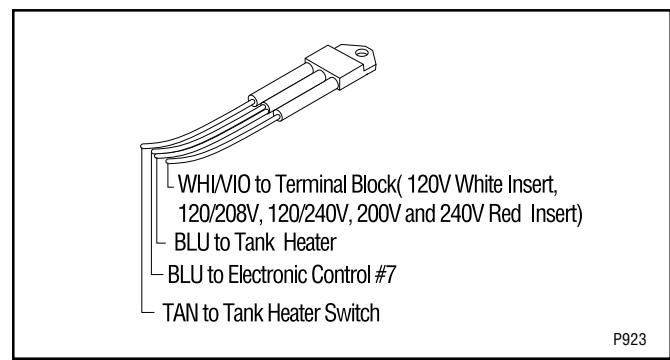

**Triac Assembly Removal and Replacement**

NOTE - each triac installation requires the use of an approved silicone heat sink compound. Bunn-O-Matic recommends the use of Dow Corning 340 compound or equivalent. It can be purchased direct from Bunn-O-Matic (part number M2522.0002).

1. Place the tank heater switch on the electronic control assembly in the "OFF" position.
2. Completely drain the tank.
3. Place a styrofoam or wood block between the center of the tank and the rear of the brewer.
4. Disconnect triac wires, white/violet from terminal block, blue from tank heater, blue from electronic control and tan from tank heater switch.
5. Carefully set the brewer on its back.
6. Remove the 2" dia hole plug from the bottom cover.

## SERVICE (cont.)

### LEVEL CONTROL BOARD AND LEVEL PROBE (Electro/mechanical only)

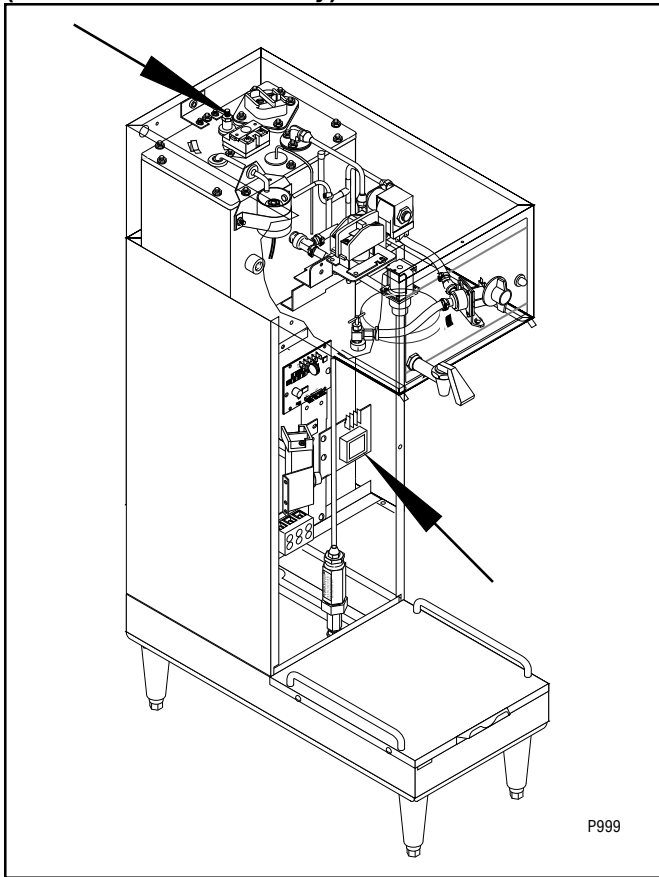

#### Location:

The level control board is located inside the front in center of the brewer on the component bracket. The level probe is located inside the hood on the center rear of the tank lid.

#### Test Procedure:

1. Disconnect the brewer from the power source.
2. Remove the violet wire from terminal 1 & pink wire from terminal 4 of the circuit board.
3. Check the voltage across terminals 2 & 3 with a voltmeter. Connect the brewer to the power source. The indication must be:
  - a.) 120 volts ac for two wire 120 volt models, three wire 120/208 volt models and three wire 120/240 volt models.
  - b.) 200 to 240 volts ac for two wire 200 or 240 volt models.
4. Disconnect the brewer from the power source.

If voltage is present as described, proceed to #5.  
If voltage is not present as described, refer to the wiring diagrams and check the brewer wiring harness.

5. Reconnect the violet wire to terminal 1.
6. Carefully connect a piece of insulated jumper wire to terminal 4. Keep the other end of this wire away from any metal surface of the brewer.
7. Check the voltage across terminals 1 & 3 with a voltmeter. Connect the brewer to the power source. The indication must be:
  - a.) 120 volts ac for two wire 120 volt models, three wire 120/208 volt models and three wire 120/240 volt models after a delay of approximately 1 second.
  - b.) 200 to 240 volts ac for two wire 200 or 240 volt models after a delay of approximately 1 second.
8. Touch the free end of jumper wire to the brewer housing. The indication must be 0.
9. Move the jumper wire away from the brewer housing. The indication must again be:
  - a.) 120 volts ac for two wire 120 volt models, three wire 120/208 volt models and three wire 120/240 volt models after a delay of approximately 1 second.
  - b.) 200 to 240 volts ac for two wire 200 or 240 volt models after a delay of approximately 1 second.
10. Disconnect the brewer from the power source and remove the jumper wire from terminal 4.

If voltage is present as described, the level control board is operating properly, proceed to #11.

If voltage is not present as described, replace the level control board.

11. Reconnect the pink wire to terminal 4.
12. Gently pull the probe out of the tank lid and inspect for corrosion. Replace it if necessary.
13. Place the probe so that neither end is in contact with any metal surface of the brewer.
14. Check the voltage across terminals 1 & 3 with a voltmeter. Connect the brewer to the power source. The indication must be:
  - a.) 120 volts ac for two wire 120 volt models, three wire 120/208 volt models and three wire 120/240 volt models after a delay of approximately 1 second.
  - b.) 200 to 240 volts ac for two wire 200 or 240 volt models after a delay of approximately 1 second.
15. Move the probe's flat end to the brewer housing. The indication must be 0.
16. Move the probe's flat end away from the brewer

## SERVICE (cont.)

### LEVEL CONTROL BOARD AND LEVEL PROBE (Electro/mechanical only)(cont.)

housing. The indication should again be  
a.) 120 volts ac for two wire 120 volt models, three  
wire 120/208 volt models and three wire 120/240  
volt models.

b.) 200 to 240 volts ac for two wire 200 or 240 volt  
models after a delay of approximately 1 second.

17. Disconnect the brewer from the power source.

If voltage is present as described, reinstall the probe,  
the level control board and level probe are operating  
properly.

If voltage is not present as described, check the pink  
probe wire for continuity.

#### Removal and Replacement:

1. Remove all wires from the level control board.
2. Remove two #8-32 slotted head screws and lockwashers holding level control board to component bracket.
3. Install the new level control board to the component bracket. Make certain that the lockwashers are between the level control board and the component bracket.
4. Refer to the illustration below when reconnecting the wires.

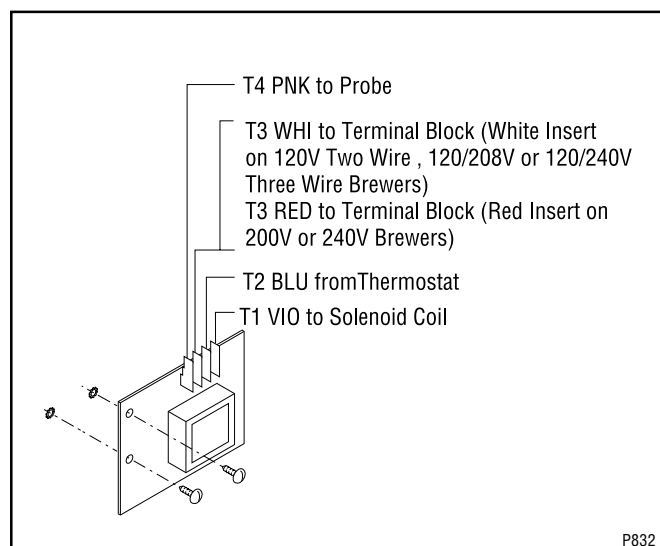

## SERVICE (cont.)

### LIMIT THERMOSTAT

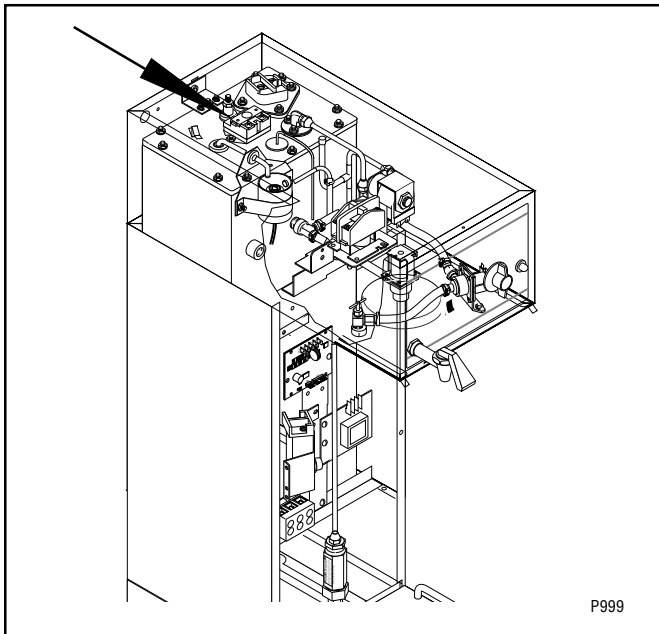

#### Location:

The limit thermostat is located inside the hood on the tank lid just to the left of the tank heater.

#### Test Procedure:

1. Disconnect the brewer from the power supply.
2. Disconnect both black wires from the limit thermostat.
3. Check for continuity across the limit thermostat terminals with a ohmmeter.

If continuity is present as described, reconnect the black wires to the limit thermostat, the limit thermostat is operating properly.

If continuity is not present as described, press the reset button on the limit thermostat and repeat step #3.

After repeating step #3 no continuity is shown, replace the limit thermostat.

#### Removal and Replacement

1. Remove all wires from the limit thermostat terminals.
2. Carefully remove the two #8-32 nuts securing the limit thermostat to tank lid and remove limit thermostat.
3. Carefully secure new limit thermostat to tank lid.
4. Refer to the illustration below when reconnecting the wires.

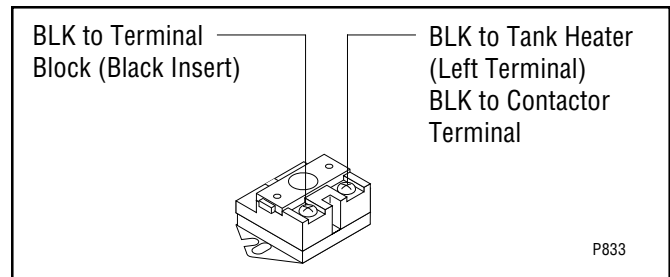

## SERVICE (cont.)

### ON/OFF SWITCH

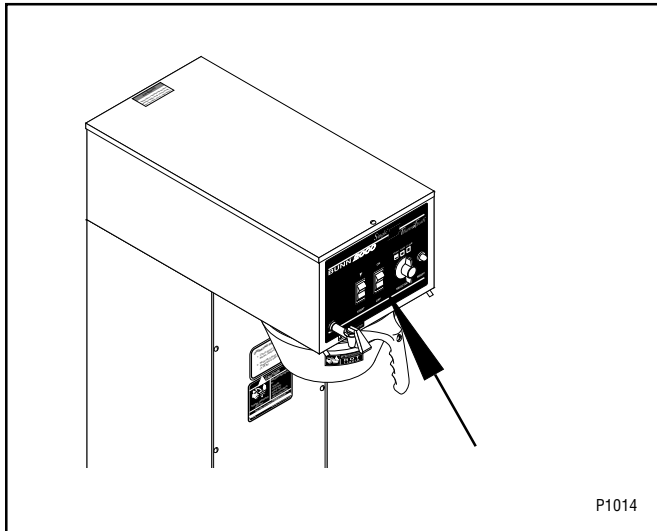

#### Location:

The ON/OFF switch is located on the front of the hood in the center to the right of the start switch.

#### Test Procedure:

1. Disconnect the brewer from the power source.
2. Viewing the switch from the back remove the red or white wire from the upper right terminal and the black wire from the center terminal.
3. Check the voltage across the red or white wire and the black wire with a voltmeter. Connect the brewer to the power source. The indication must be:
  - a.) 120 volts ac for two wire 120 volt models, three wire 120/208 volt models and three wire 120/240 volt models.
  - b.) 200 to 240 volts ac for two wire 200 or 240 volt models.
4. Disconnect the brewer from the power source.

If voltage is present as described, reconnect the red or white wire, and proceed to #5.

If voltage is not present as described, refer to the *Wiring Diagrams* and check the brewer wiring harness.

5. With the black wire removed, remove the white/violet wire on the switch from the lower left terminal.
6. Check for continuity across the center and lower left terminal with switch in the "ON" position. Continuity must not be present when switch is in the "OFF" position.

If continuity is present as described, reconnect the black wire to the center terminal and the white/violet wire on the switch to the lower left terminal.

If continuity is not present as described, replace the switch.

#### Removal and Installation:

1. Remove the wires from the switch terminals.
2. Compress the clips inside the hood and gently push the switch through the opening.
3. Push the new switch into the opening and spread the clips to hold switch in the hood.
4. Refer to the following below when reconnecting the wires.

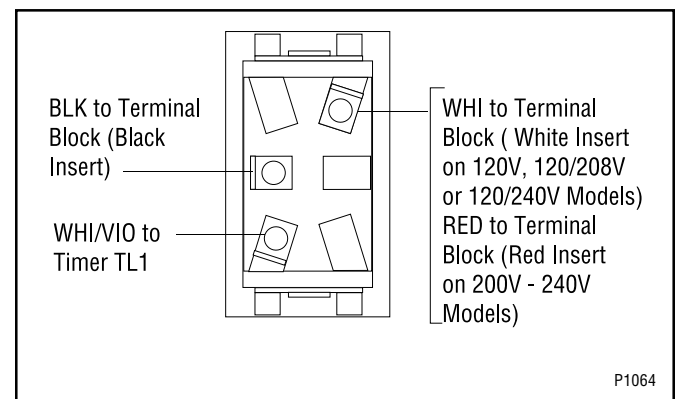

## SERVICE (cont.)

### OVERFLOW PROTECTION SWITCH

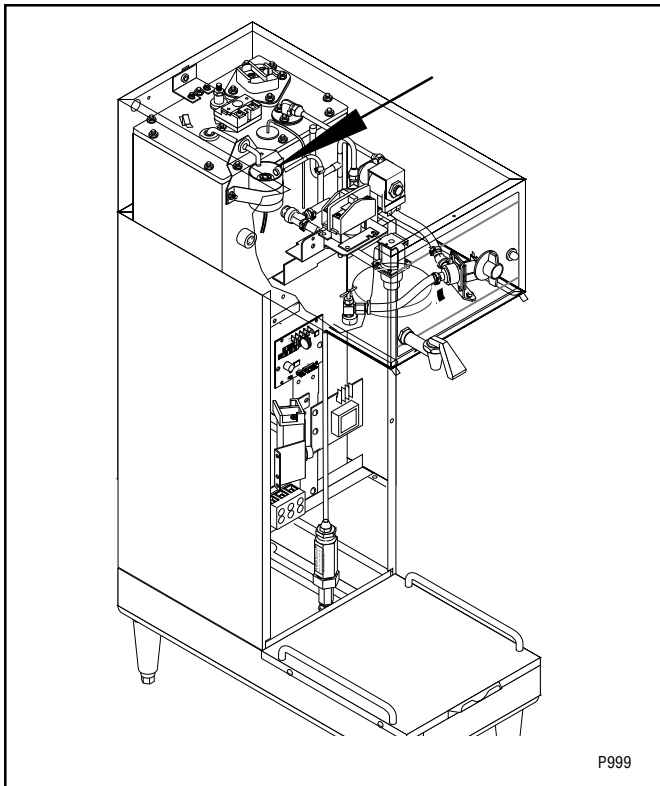

#### Location:

The overflow protection switch is located inside the hood on the tank inside the copper overflow cup.

To test the overflow protection switch, access will also be needed to the level control board or electronic control assembly and terminal block.

#### Test Procedure:

1. Disconnect the brewer from the power source.
2. Remove the wire nuts connecting the red wires from the overflow protection switch to the black wire from the terminal block and blue wire from the thermostat or the black wire from the electronic control assembly.
3. Check for continuity across the safety overflow switch red wires only until the plastic float is raised and check that continuity returns when the plastic float is again lowered.

If continuity is present as described, reconnect the red wires to the black wire from the terminal block and the blue wire from the thermostat or black wire from electronic control assembly.

If continuity is not present as described, replace the safety overflow switch.

#### Removal and Replacement:

1. Disconnect the red leads from the overflow protection switch from the black wire from the terminal block and the blue wire from the thermostat or black wire from electronic control assembly.
2. Remove the nut beneath the copper overflow cup.
3. Remove the entire switch assembly from the cup.
4. Place the new switch assembly into the cup, wires first. Make sure that a gasket is in place around the threaded switch stem.

**NOTE** - The magnets must be at the top of float and there must be NO adjusting washers installed for the overflow protection switch to operate properly.

5. Install the nut beneath the copper overflow cup. Be sure not to overtighten.
6. Refer to the illustration below when reconnecting wires.

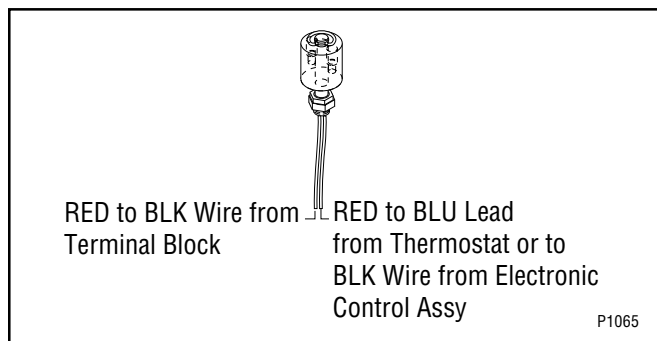



## SERVICE (cont.)

### SERVER SENSOR

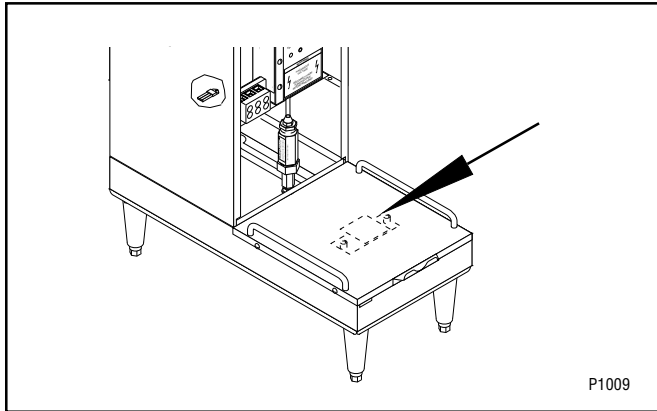

#### Location:

The server sensor is attached to the bottom side of the server platform.

With brew selector switch in the 1/2 gallon position the server sensor will allow a brew cycle to start with a 1/2 gallon server only.

With brew selector switch in the 1 gallon or 1-3/4 gallon position the server sensor will allow a brew cycle to start with a 1-3/4 gallon server only.

If the correct server is used for the selected batch size and the brew cycle will not start, proceed with the test procedures.

#### Test Procedures:

1. Disconnect the brewer from the power source.
2. Disconnect the terminal plug on the wiring harness from terminal plug on the server sensor.
3. Check the voltage across the gray wire (pin #1) and the white wire or red wire (pin #2) on the wiring harness with a voltmeter and with the "ON/OFF" switch in the "ON" position. Connect the brewer to the power source. The indication must be:
  - a.) 120 volts ac for two wire 120 volt models, three wire 120/208 volt models and three wire 120/240 volt models.
  - b.) 200 to 240 volts ac on two wire 200 or 240 volt models.
4. Disconnect the brewer from the power source.

If voltage is present as described, proceed to #5.

If voltage is not present as described, refer to the wiring diagrams and check the brewer wiring harness.

**NOTE:** ECA MODELS ONLY - Brewer must be at operating temperature to perform step #5 or brew-lock must be bypassed. To bypass brew-lock disconnect white/yellow and orange wires from interlock of ECA and connect harness leads together.

5. Disconnect the white/yellow wire from timer terminal TL5.
6. Check for continuity between the white/yellow wire disconnected from timer terminal TL5 and the yellow wire (pin #4) on the server sensor terminal plug of the wiring harness with the brew selector switch in the 1/2 batch position and the start switch depressed.
7. Select the 1 gallon or 1-3/4 gallon setting on the brew selector switch.
8. Check for continuity between the white/yellow wire disconnected from timer terminal TL5 and the orange wire (pin #3) on the server sensor terminal plug of the wiring harness and the start switch depressed.
9. Reconnect the white/yellow to timer terminal TL5 and brew-lock if necessary.
10. Disconnect the pink wire from timer terminal TL3.
11. Check continuity between the pink wire removed from timer terminal TL3 and the pink wire (pin #5) on the server sensor terminal plug of the wiring harness.
12. Reconnect the pink wire to timer terminal TL3.

If continuity is present as described the server sensor wiring is operating properly. Replace the server sensor. If continuity is not present as described refer to the wiring diagrams and check brewer wiring harness.

#### Removal and Replacement:

1. Remove the four #6-32 slotted head screws securing the server platform to the brewer base.
2. Lift server platform high enough to be able to disconnect the server sensor terminal plug from the terminal plug on the wiring harness. Disconnect the plugs.
3. Turn the server platform over and remove the two #8-32 Keps nuts securing the server sensor to the weld stud on the server platform.
4. Remove the server sensor leaving the two spacers in place.
5. Install new server sensor on the weld studs and secure with two #8-32 Keps nuts.
6. Reconnect the terminal plug on the server sensor to the terminal plug on the wiring harness.
7. Reinstall server platform on the brewer base using four #6-32 Slotted head screws.

**SERVICE (cont.)**  
**SOLENOID VALVE (Inlet)**

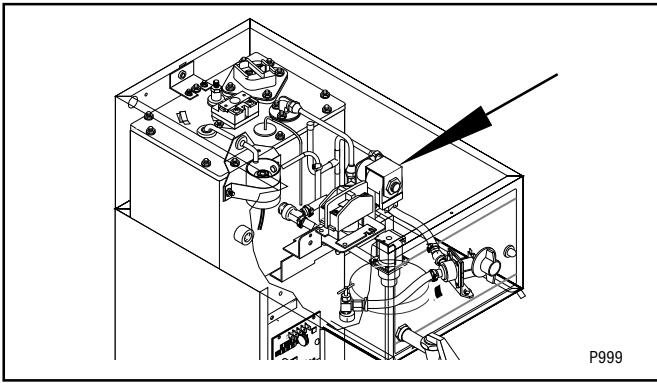

Location:

The inlet solenoid valve is located inside the hood on the right side of the upper component bracket.

Test Procedure:

1. Disconnect the brewer from the power source.
2. Remove both wires from the solenoid valve coil terminals.
3. Check the voltage across the removed wires:
  - a.) White and violet wires on 120, 120/208 and 120/240 volt electro/mechanical controlled brewers.
  - b.) White and white/blue on 120, 120/208 and 120/240 volt electronic controlled brewers.
  - c.) Red and violet wires on 200 or 240 volt electro/mechanical control brewers.
  - d.) Red and white/blue on 200 or 240 volt electronic controlled brewers.
 with a voltmeter. Connect the brewer to the power source. The indication must be:
  - e.) 120 volts ac for two wire 120 volt models, three wire 120/208 volt models and three wire 120/240 volt models.
  - f.) 200 to 240 volts ac for two wire 200 or 240 volt models.

If continuity is present as described, reconnect the white and violet wires on the electro/mechanical controlled 120, 120/208 and 120/240 volt brewers, white and white/blue on electronic controlled 120, 120/208 and 120/240 volt brewers, red and violet on electro/mechanical controlled 200 or 240 volt brewers and red and white/blue on electronic controlled 200 or 240 volt brewers.

If continuity is not present as described, replace the

4. Disconnect the brewer from the power source

If voltage is present as described, proceed to #5. If voltage is not present as described, refer to the wiring diagrams and check brewer wiring harness.

5. Check for continuity across the solenoid valve coil terminals.  
solenoid valve.
6. Check the solenoid valve for coil action. Connect the brewer to the power source. Listen carefully in the vicinity of the solenoid valve for a "clicking" sound after approximately 1 second, as the coil magnet attracts.
7. Disconnect the brewer from the power source.

If the sound is heard as described and water will not pass through the solenoid valve, there may be a blockage in the water line before or after the solenoid valve or, the solenoid valve may require inspection for wear, and removal of waterborne particles.

If the sound is not heard as described, replace the solenoid valve.

Removal and Replacement:

1. Remove all wires from the solenoid valve coil.
2. Turn-off the water supply to the brewer.
3. Disconnect the water lines to and from the solenoid valve.
4. Remove the two #10-32 slotted head screws and lockwashers holding the solenoid valve to the upper component bracket.
5. Lift-out the solenoid valve.
6. Securely install the new solenoid valve to the upper component bracket.
7. Securely fasten the water lines to and from the solenoid valve.
8. Refer to the illustration below when reconnecting the wires.

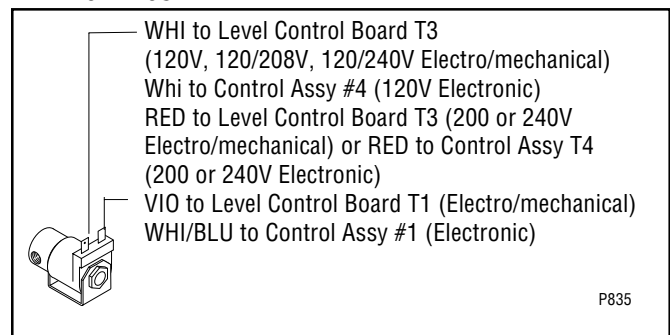

**SERVICE (cont.)**  
**START SWITCH**

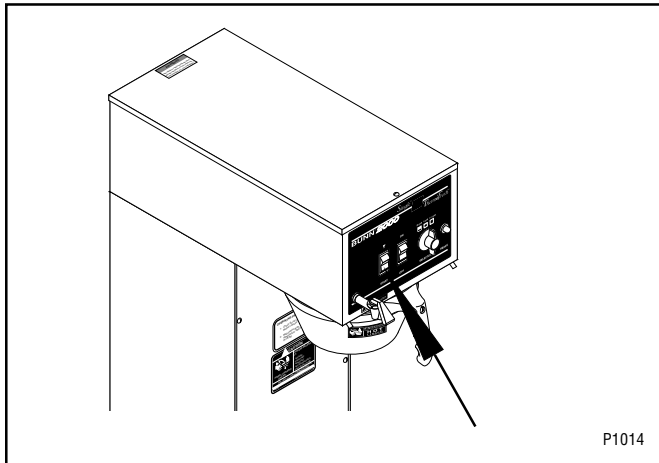

Location:

The momentary start switch is located in front of hood just to the left of the ON/OFF switch.

Test Procedure:

1. Disconnect the brewer from the power source and remove the wires from both terminals of the switch.
2. Check for continuity across the two terminals on the switch when it is held in the lower position. Continuity must not be present across these terminals in the upper position.

If continuity is present as described, reconnect the wires, the switch is operating properly.

If continuity is not present as described, replace the switch.

Removal and Replacement:

1. Remove all wires from the switch terminals.
2. Compress the clips inside the hood and gently push the switch through the opening.

3. Push the new switch into the opening and spread the clips to hold the switch in the hood.
4. Refer to the following illustration when reconnecting the wires.

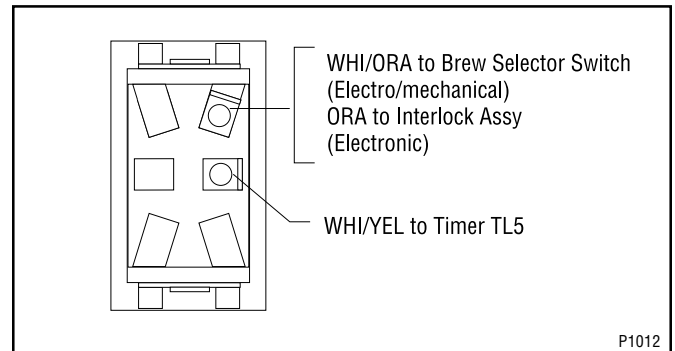

## SERVICE (cont.)

### TANK HEATER

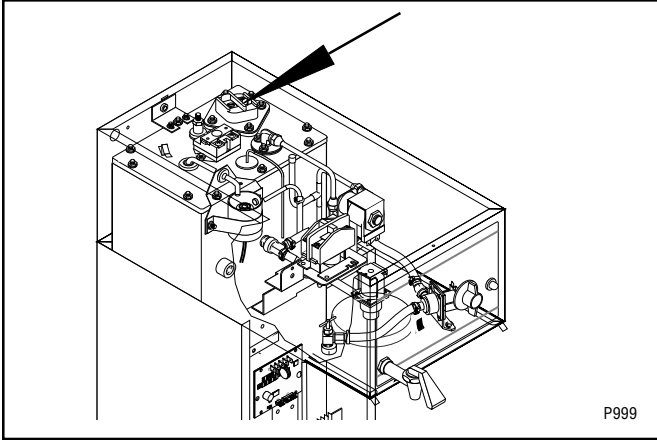

#### Location:

The tank heater is located inside the hood on the right rear of the tank lid.

#### Test Procedure:

##### Electro/Mechanical Models.

1. Disconnect the brewer from the power supply.
2. Check the voltage across the black and the red wire on 120V, 208 or 240V models on the tank heaters. With the control thermostat turned to the "ON" position (fully clockwise), connect the brewer to the power supply and check the voltage across the wires with a voltmeter. The indication should be:
  - a.) 120 volts ac for two wire 120 volt models, 208 volts ac for three wire 120/208 volt models and 240 volts ac for three wire 120/240 volt models.
  - b.) 200 to 240 volts ac for two wire 200 or 240 volt models.
3. Disconnect the brewer from the power supply.

If voltage is present as described, proceed to #4.  
If voltage is not present as described, refer to the wiring diagrams and check the wiring harness.

4. Disconnect wires from the tank heater.
5. Check for continuity across the terminals of the tank heater.

If continuity is present as described, reconnect the wires, the tank heater is operating properly. If continuity is not present as described, replace the tank heater.

**NOTE** - If the tank heater remains unable to heat, remove and inspect the heater for cracks in the sheath.

**SERVICE (cont.)**  
**TANK HEATER (cont.)**

Electronic Control Models:

1. Disconnect the brewer from the power source.
2. Disconnect wires from heater.
3. Check for continuity across the tank heater terminals.

If continuity is present as described, the tank heater is operating properly.

If continuity is not present as described, replace the tank heater.

**NOTE** - If the tank heater remains unable to heat, remove and inspect the heater for cracks in the sheath.

Removal and Replacement:

1. Remove wires from tank heater.
2. Remove the four #8-32 nuts securing tank heat to tank lid.
3. Remove tank heater and gasket.
4. Install new tank heater and gasket with four #8-32 nuts on tank lid.
5. Refer to the illustration below when reconnecting the wires.

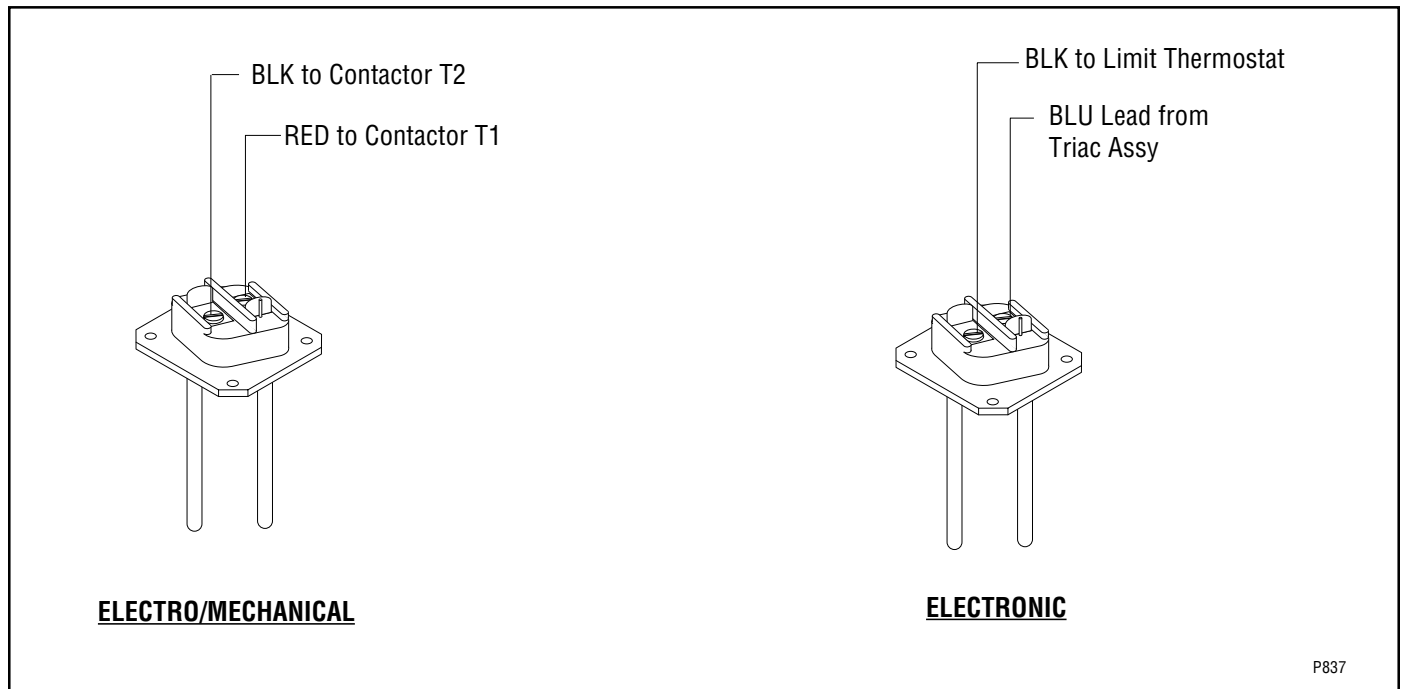

P837

## SERVICE (cont.)

### TIMER (First Type)

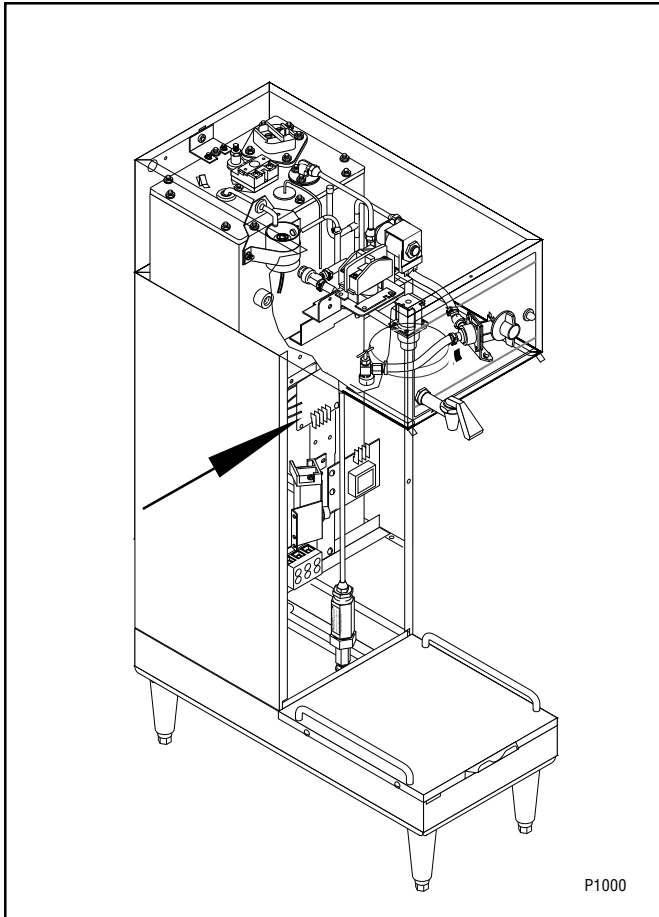

#### Location:

The timer is located inside the left front of the brewer on the upper part of the component bracket.

#### Test Procedures:

1. Disconnect the brewer from the power source.
2. Disconnect the wires from the timer terminals TL3, TL4 and TL5 and rotate the dial(s) fully counterclockwise.
3. Check the voltage across terminals TL1 and TL2 with a voltmeter when the "ON/OFF" switch is in the "ON" position. Connect the brewer to the power source. The indication must be:
  - a.) 120 volts ac for two wire 120 volt models, three wire 120/208 volt models and three wire 120/240 volt models.
  - b.) 200 to 240 volts ac for two wire 200 or 240 volt models.
4. Disconnect the brewer from the power source.

If voltage is present as described, reconnect pink wire to TL3, white/green wire to TL4, white/yellow wire to

TL5 and proceed to #5.

If voltage is not present as described, refer to the wiring diagrams and check the brewer wiring harness.

**NOTE:** ECA MODELS ONLY - Brewer must be at operating temperature to perform step #5 or brew-lock must be bypassed. To bypass brew-lock disconnect white/yellow and orange wires from interlock of ECA and connect harness leads together.

5. Place 1/2 gallon server under the funnel and select 1/2 gallon position on selector switch.
6. Check the voltage across terminals TL1 and TL4 with a voltmeter when the "ON/OFF" switch is in the "ON" position. Connect the brewer to the power source and press the start switch. The indication must be:
  - a.) 120 volts ac for two wire 120 volt models, three wire 120/208 volt models and three wire 120/240 volt models for approximately 20 seconds for 1/2 gallon batch.
  - b.) 200 to 240 volts ac for two wire 200 or 240 volt models for approximately 20 seconds for 1/2 gallon batch.
7. Place 1-3/4 gallon server under funnel. Select a 1 gallon batch and repeat #6. The voltage indication should remain for approximately 40 seconds.
8. Select a 1-3/4 gallon batch and repeat #6. The indication should remain approximately 1 minute.
9. Reconnect brew-lock wires if necessary.

If voltage is present as described timer is operating properly.

If voltage is not present as described, replace the timer.

#### Removal and Replacement:

1. Remove all wires from the timer.
2. Remove the four #6-32 slotted head screws holding circuit board and dial plate on to the component mounting bracket.
3. Remove circuit board, nylon spacers and dial plate.
4. Install new dial plate and circuit board with nylon spacers to component mounting bracket.
5. Refer to the illustration on the following page when reconnecting wires.
6. Adjust timer dial(s) as required.

**SERVICE (cont.)**

**TIMER (First Type)(cont.)**

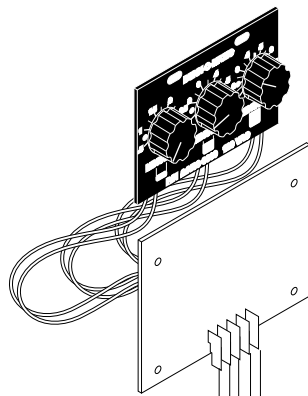

- WHI/VIO TL1 to ON/OFF Switch
- WHI/VIO TL1 to Server Sensor
- WHI TL2 to Terminal Block and Server Sensor  
(120V Two Pole, 120/208V or 120/240V Three Pole  
Terminal Block)
- RED TL2 to Terminal Block and Server Sensor  
(200V or 240V Two Pole Terminal Block)
- PNK TL3 to Server Sensor PNK (Pin 5)
- WHI/GRN TL4 to Dispense Valve
- WHI/YEL TL5 to Start Switch

P1011

## SERVICE (cont.)

### DIGITAL TIMER (SecondType)

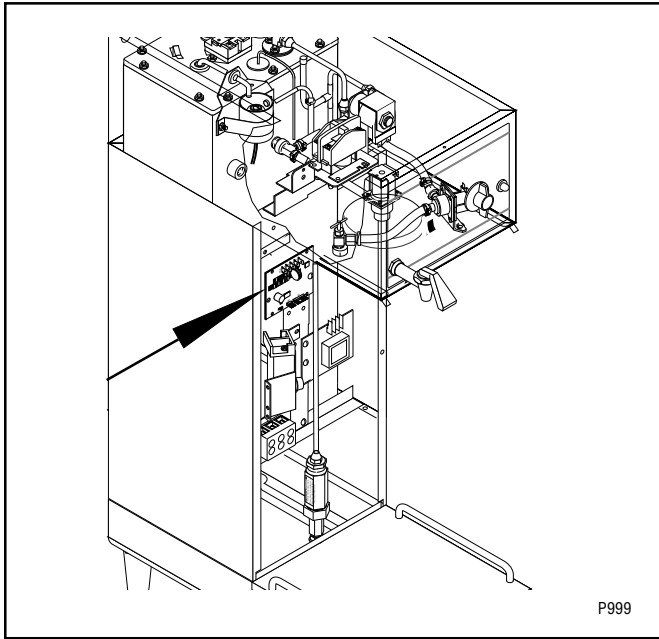

#### Location:

The timer is located inside the left front of the brewer on the upper part of the component bracket.

#### Test Procedures:

**NOTE:** Do not remove or install wires while timer board is installed. Pressure applied to one side may cause damage to the board.

1. Disconnect the brewer from the power source and remove the front panel.
2. Check the voltage across terminals TL1 and TL2 with a voltmeter when the "ON/OFF" switch is in the "ON" position. Connect the brewer to the power source. The indication must be:
  - a.) 120 volts ac for two wire 120 volt models, three wire 120/208 volt models and three wire 120/240 volt models.
  - b.) 200 to 240 volts ac for two wire 200 or 240 volt models.
3. Disconnect the brewer from the power source.

If voltage is present as described, proceed to #4.

If voltage is not present as described, refer to the wiring diagrams and check the brewer wiring harness.

4. Disconnect the WHI/ORA wire from terminal TL3 and the WHI/YEL wire from terminal TL5. Check for continuity across the two wires when the start switch is pressed to the "START" position.

If continuity is present as described, reconnect the wires and proceed to #5.

If continuity is not present as described, refer to the wiring diagrams and check the brewer wiring harness.

5. Check the voltage across terminals TL1 and TL4 with a voltmeter when the "ON/OFF" switch is in the "ON" position. Connect the brewer to the power source. The indication must be zero volts.

If voltage indications are other than described, disconnect the brewer from the power source and replace the timer.

6. Check the voltage across terminals TL1 and TL4 with a voltmeter when the "ON/OFF" switch is in the "ON" position. Connect the brewer to the power source and press the start switch. The indication must be:
  - a.) 120 volts ac for two wire 120 volt models, three wire 120/208 volt models and three wire 120/240 volt models.
  - b.) 200 to 240 volts ac for two wire 200 or 240 volt models.

If voltage indications are other than described, disconnect the brewer from the power source and replace the timer.

7. Remove the test equipment and connect all wires as described below.

#### Removal and Replacement:

**NOTE:** Do not remove or install wires while timer board is installed. Pressure applied to one side may cause damage to the board.

1. Remove the four #6-32 screws securing circuit board to component mounting bracket.
2. Remove circuit board and nylon spacers.
3. Remove all wires from the timer.
4. Attach all wires to the replacement timer board prior to installation to the component mounting bracket. Refer to illustration below when reconnecting the wires.
5. Install new circuit board with nylon spacers to component mounting bracket using two #6-32 screws.
6. Adjust the timer as described below.



## SERVICE (cont.)

### TIMERS (Second Type)(cont.)

#### Timer Setting:

**NOTE:** Check that the brewer is connected to water supply, the tank is properly filled, and a funnel and server are in place, prior to setting or modifying volumes.

**NOTE:** All volume settings must be done with the sprayhead installed.

1. **Modifying brew volumes.** To modify a brew volume, first check that the SET/LOCK switch is in the "SET" position on the circuit board.

**To increase a brew volume,** place the ON/OFF switch in the "ON" position, press and hold the START switch until three clicks are heard. Release the switch (Failure to release the switch within two seconds after the third click causes the volume setting to be aborted and previous volume setting will remain in memory) and press it again one or more times. Each time the switch is pressed, two seconds are added to the brew time period. Allow the brew cycle to finish in order to verify that the desired volume has been achieved.

**To decrease a brew volume,** place the ON/OFF switch in the "ON" position, press and release the START switch once for every two-second interval to be removed from the total brew time period; then immediately press and hold down the START switch until three clicks are heard. Release the switch. (Failure to release the switch within two seconds after the third click causes the volume setting to be aborted and previous volume setting will remain in memory). Allow the brew cycle to finish in order to verify that the desired volume has been achieved.

2. **Setting brew volumes.** To set a brew volume, first check that the SET/LOCK switch is in the "SET" position on the circuit board. Place the ON/OFF switch in the "ON" position, press and hold the START switch until three distinct clicks are heard and then release the switch. (Failure to release the switch within two seconds after the third click causes the volume setting to be aborted and previous volume setting will remain in memory).

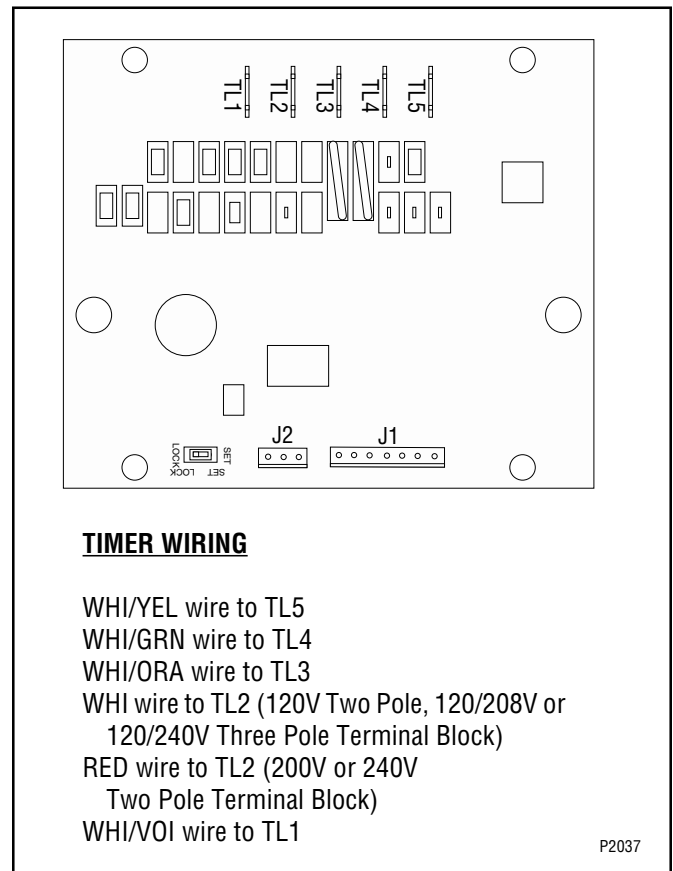

#### TIMER WIRING

WHI/YEL wire to TL5  
WHI/GRN wire to TL4  
WHI/ORA wire to TL3  
WHI wire to TL2 (120V Two Pole, 120/208V or  
120/240V Three Pole Terminal Block)  
RED wire to TL2 (200V or 240V  
Two Pole Terminal Block)  
WHI/VOI wire to TL1

P2037

View the level of the liquid being dispensed. When the desired level is reached, turn the ON/OFF switch to "OFF". **NOTE:** Several ounces of water will continue to syphon from the tank after turning the switch "OFF". The brewer remembers this volume and will continue to brew batches of this size until the volume setting procedure is repeated.

**NOTE:** When brewing coffee, volumes will decrease due to absorption by the coffee grounds.

3. **Setting programming disable feature.** If it becomes necessary to prevent anyone from changing brew time once programmed, you can set the SET/LOCK switch to the "LOCK" position. This will prevent any further programming.

# SCHEMATIC WIRING DIAGRAM SINGLE BREWER ECA-TF W/ SERVER SENSOR

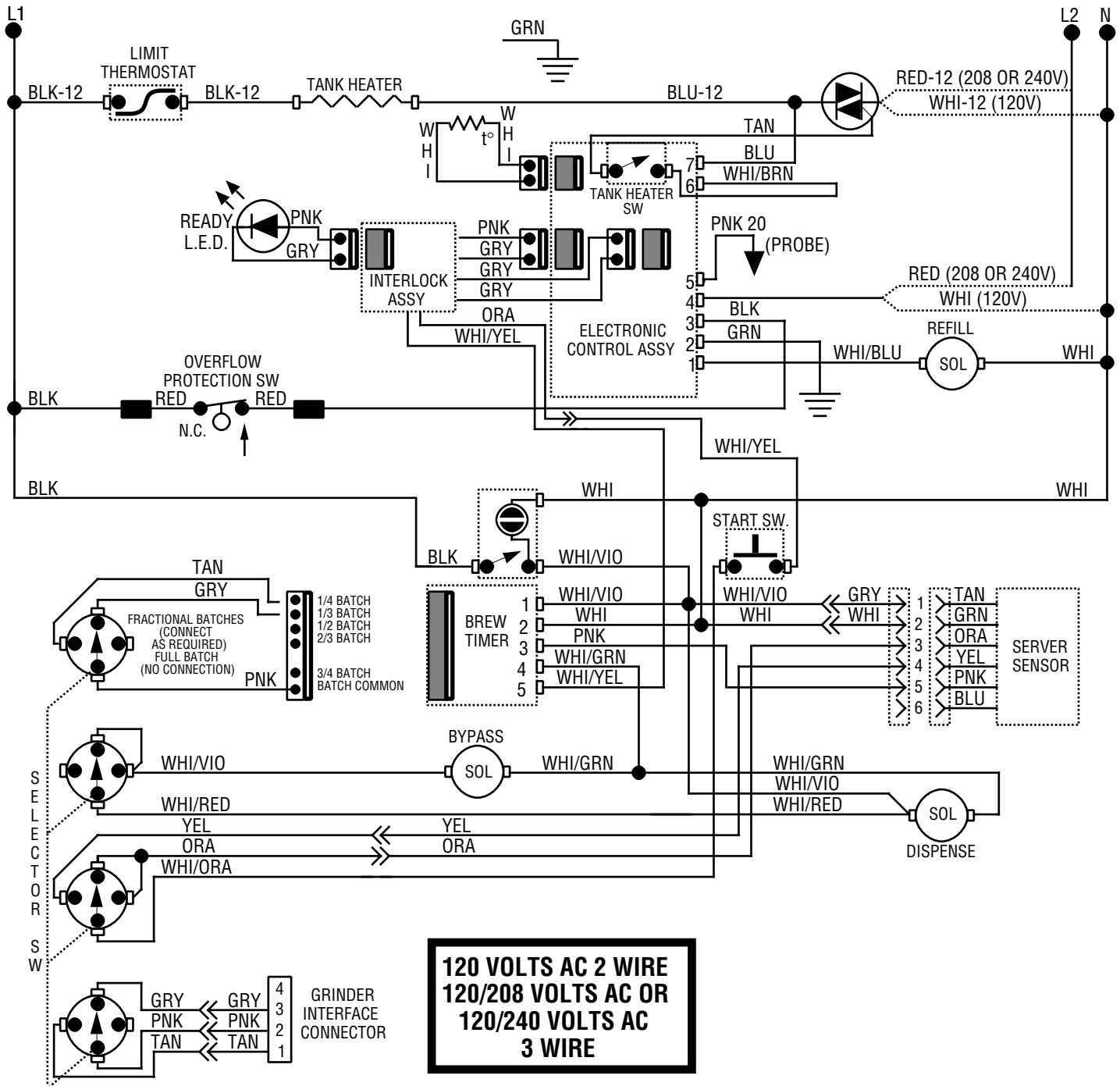

# SCHEMATIC WIRING DIAGRAM SINGLE BREWER W/ SERVER SENSOR

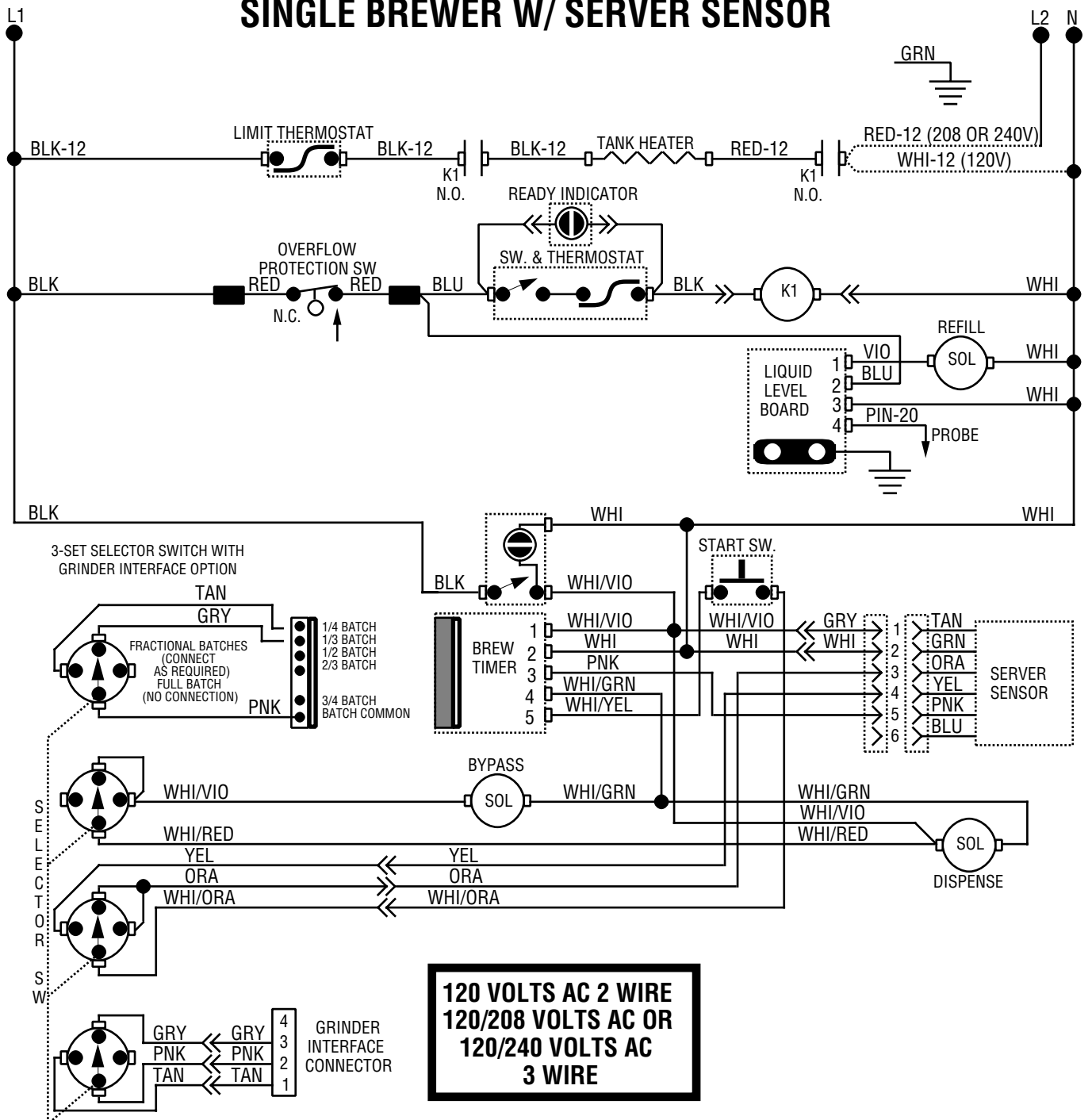

# SCHEMATIC WIRING DIAGRAM SINGLE BREWER ECA-ATF & BTF W/ SERVER SENSOR

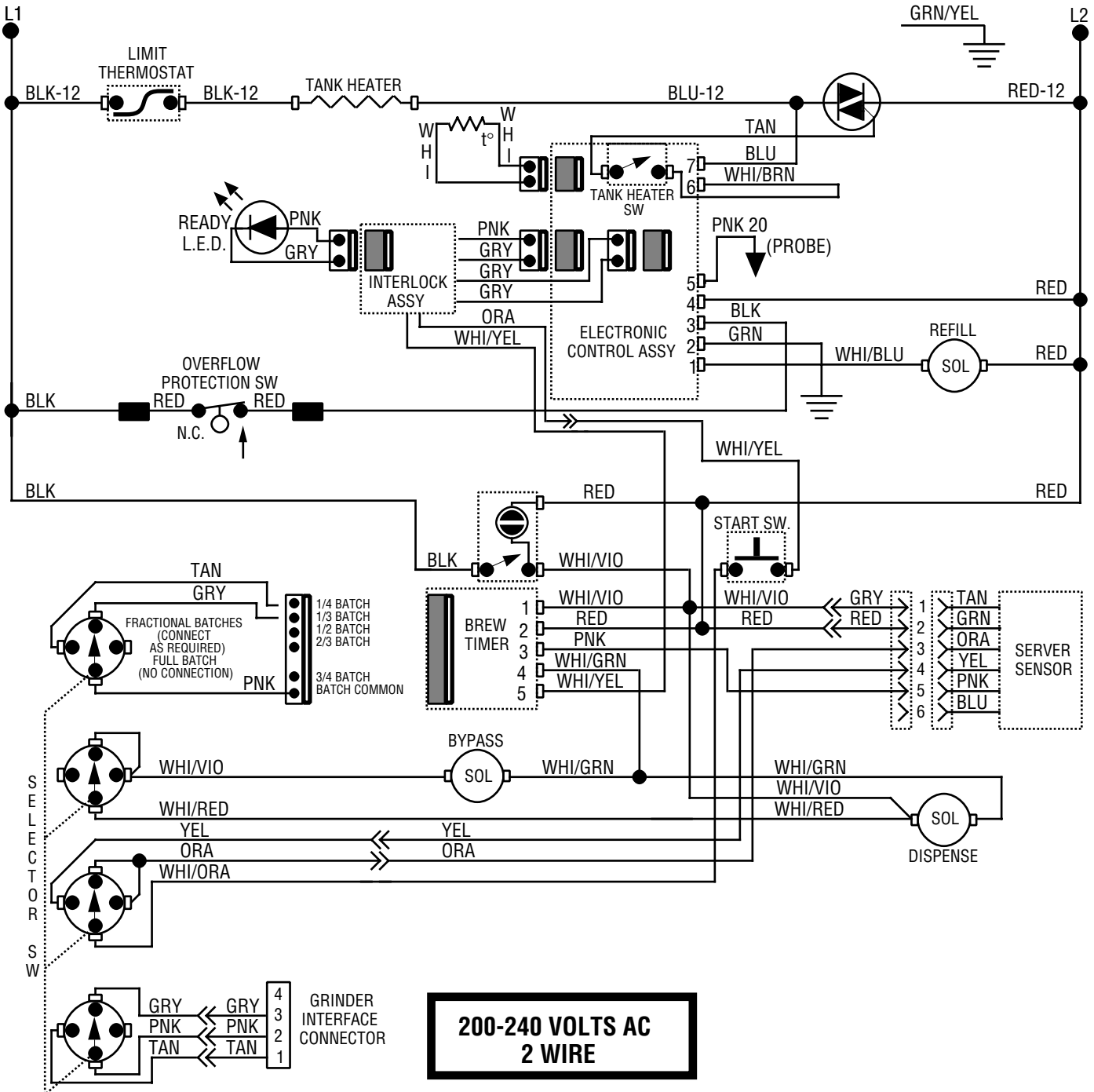

# SCHEMATIC WIRING DIAGRAM SINGLE BREWER-ATF OR -BTF W/ SERVER SENSOR

