

BUNN®

SLCA-7



ILLUSTRATED PARTS CATALOG

Designs, materials, weights, specifications, and dimensions for equipment or replacement parts are subject to change without notice.

BUNN-O-MATIC CORPORATION

POST OFFICE BOX 3227

SPRINGFIELD, ILLINOIS 62708-3227

PHONE: (217) 529-6601 FAX: (217) 529-6644

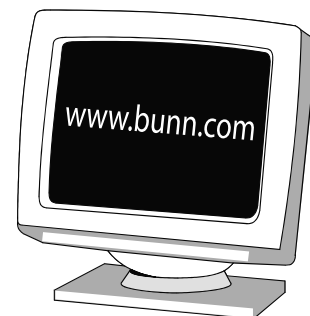

BUNN-O-MATIC COMMERCIAL PRODUCT WARRANTY

Bunn-O-Matic Corp. ("BUNN") warrants equipment manufactured by it as follows:

- 1) Airpots, thermal carafes, decanters, GPR servers, iced tea/coffee dispensers, MCR/MCP/MCA single cup brewers, thermal servers and ThermoFresh® servers (mechanical and digital) 1 year parts and 1 year labor.
- 2) All other equipment - 2 years parts and 1 year labor plus added warranties as specified below:
 - a) Electronic circuit and/or control boards - parts and labor for 3 years.
 - b) Compressors on refrigeration equipment - 5 years parts and 1 year labor.
 - c) Grinding burrs on coffee grinding equipment to grind coffee to meet original factory screen sieve analysis - parts and labor for 4 years or 40,000 pounds of coffee, whichever comes first.

These warranty periods run from the date of installation BUNN warrants that the equipment manufactured by it will be commercially free of defects in material and workmanship existing at the time of manufacture and appearing within the applicable warranty period. This warranty does not apply to any equipment, component or part that was not manufactured by BUNN or that, in BUNN's judgment, has been affected by misuse, neglect, alteration, improper installation or operation, improper maintenance or repair, non periodic cleaning and descaling, equipment failures related to poor water quality, damage or casualty. In addition, the warranty does not apply to replacement of items subject to normal use including but not limited to user replaceable parts such as seals and gaskets. This warranty is conditioned on the Buyer 1) giving BUNN prompt notice of any claim to be made under this warranty by telephone at (217) 529-6601 or by writing to Post Office Box 3227, Springfield, Illinois 62708-3227; 2) if requested by BUNN, shipping the defective equipment prepaid to an authorized BUNN service location; and 3) receiving prior authorization from BUNN that the defective equipment is under warranty.

THE FOREGOING WARRANTY IS EXCLUSIVE AND IS IN LIEU OF ANY OTHER WARRANTY, WRITTEN OR ORAL, EXPRESS OR IMPLIED, INCLUDING, BUT NOT LIMITED TO, ANY IMPLIED WARRANTY OF EITHER MERCHANTABILITY OR FITNESS FOR A PARTICULAR PURPOSE. The agents, dealers or employees of BUNN are not authorized to make modifications to this warranty or to make additional warranties that are binding on BUNN. Accordingly, statements by such individuals, whether oral or written, do not constitute warranties and should not be relied upon.

If BUNN determines in its sole discretion that the equipment does not conform to the warranty, BUNN, at its exclusive option while the equipment is under warranty, shall either 1) provide at no charge replacement parts and/or labor (during the applicable parts and labor warranty periods specified above) to repair the defective components, provided that this repair is done by a BUNN Authorized Service Representative; or 2) shall replace the equipment or refund the purchase price for the equipment.

THE BUYER'S REMEDY AGAINST BUNN FOR THE BREACH OF ANY OBLIGATION ARISING OUT OF THE SALE OF THIS EQUIPMENT, WHETHER DERIVED FROM WARRANTY OR OTHERWISE, SHALL BE LIMITED, AT BUNN'S SOLE OPTION AS SPECIFIED HEREIN, TO REPAIR, REPLACEMENT OR REFUND.

In no event shall BUNN be liable for any other damage or loss, including, but not limited to, lost profits, lost sales, loss of use of equipment, claims of Buyer's customers, cost of capital, cost of down time, cost of substitute equipment, facilities or services, or any other special, incidental or consequential damages.

392, A Partner You Can Count On, Air Infusion, AutoPOD, AXIOM, BrewLOGIC, BrewMETER, Brew Better Not Bitter, BrewWISE, BrewWIZARD, BUNN Espresso, BUNN Family Gourmet, BUNN Gourmet, BUNN Pour-O-Matic, BUNN, BUNN with the stylized red line, BUNNlink, Bunn-O-Matic, Bunn-O-Matic, BUNNserve, BUNNSERVE with the stylized wrench design, Cool Froth, DBC, Dr. Brew stylized Dr. design, Dual, Easy Pour, EasyClear, EasyGard, FlavorGard, Gourmet Ice, Gourmet Juice, High Intensity, iMIX, Infusion Series, Intellisteam, My Café, Phase Brew, PowerLogic, Quality Beverage Equipment Worldwide, Respect Earth, Respect Earth with the stylized leaf and coffee cherry design, Safety-Fresh, savemycoffee.com, Scale-Pro, Silver Series, Single, Smart Funnel, Smart Hopper, SmartWAVE, Soft Heat, SplashGard, The Mark of Quality in Beverage Equipment Worldwide, ThermoFresh, Titan, trifacta, TRIFECTA (stylized logo), Velocity Brew, Air Brew, Beverage Bar Creator, Beverage Profit Calculator, Brew better, not bitter., Build-A-Drink, BUNNSource, Coffee At Its Best, Cyclonic Heating System, Daypart, Digital Brewer Control, Element, Milk Texturing Fusion, Nothing Brews Like a BUNN, Picture Prompted Cleaning, Pouring Profits, Signature Series, Sure Tamp, Tea At Its Best, The Horizontal Red Line, Ultra are either trademarks or registered trademarks of Bunn-O-Matic Corporation. The commercial trifacta® brewer housing configuration is a trademark of Bunn-O-Matic Corporation.

TABLE OF CONTENTS

Covers, Panels & Drip Tray	4
Door Assembly	8
Pump & Tubing	10
Cooling Fan & Air Duct.....	12
Pump Assembly.....	14
Water Inlet & Tank Drain	16
Tank Assembly	18
Dispense Valve and Lines.....	20
Auger Drive & Hopper Assy	22
Mixing/Whipper Chamber & Drive Motor.....	24
Electrical Components	28
Numerical Index.....	30

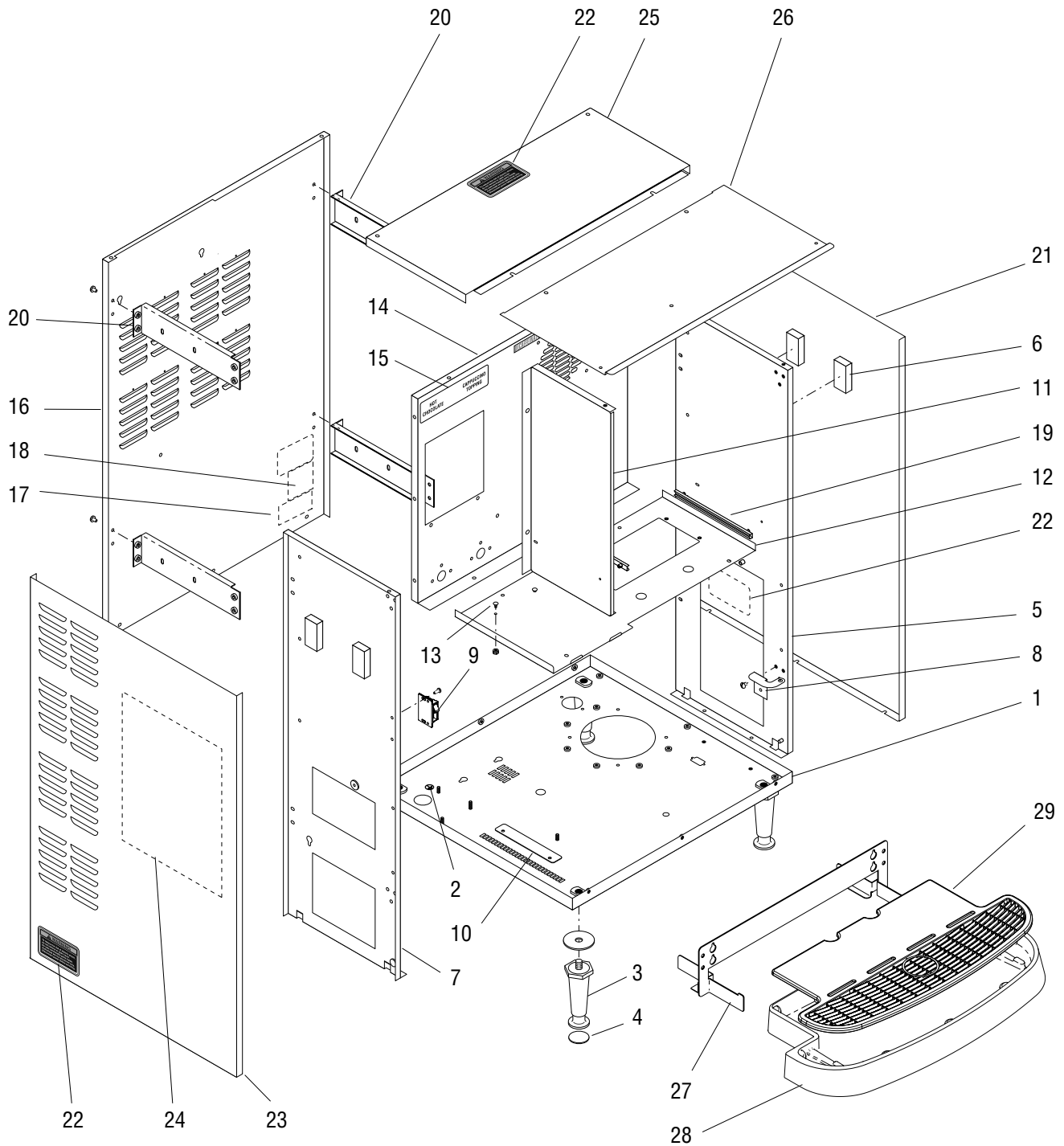

COVERS, PANELS AND DRIP TRAY

ITEM	PART NO.	QTY.	DESCRIPTION
1	38664.1003	1	Base w/Decals (Includes item 2)
2	00824.0002	1	Decal, Grounding Location
3	26528.0000	4	Leg, 4.0" Adjustable
	01526.0001	4	Washer
4	03996.0000	4	Pad, Anti Skid
5	38080.0001	1	Panel, Inner Right
	01311.0001	5	Screw, Truss Head Locking #8-32 x .25"
6	36896.0000	4	Pad
7	38082.0000*	1	Panel, Inner Left
	01311.0001	5	Screw, Truss Head Locking #8-32 x .25"
8	36647.0001	1	Bracket, Hinge, Lower Right
	01311.0001	3	Screw, Truss Head Locking #8-32 x .25"
9	34666.0000	1	Catch, Door latch
	02336.0000	2	Screw, Truss Head #4-40 x .38"
	01509.0001	2	Lockwasher, Internal-tooth #4
10	39284.0000	1	Plate, Retainer
11	45389.0000	1	Panel, Center
	01311.0001	4	Screw, Truss Head Locking #8-32 x .25"
12	38084.0003	1	Platform, Hopper Mounting
	01311.0000	4	Screw, Truss Head #8-32 x .25"
13	20960.0000	2	Shoulder Screw
	00991.0002	2	Nut, Lock #6-32
14	38077.1006	1	Panel w/Decals, Inner Rear (Includes item 15)
15	39583.0000	1	Decal, Hopper Placement
16	38990.1001	1	Panel w/Decals, Rear (Includes items 17 & 18)
	01311.0003	11	Screw, Truss Head BLK #8-32 x .25"
17	00986.0000	1	Decal, Warning Electrical
18	00656.0001	1	Decal, Comply to Plumbing
19	26008.0001	2	Mount, Card Snap-In
20	35926.0000	4	Bracket, Side Support
	01311.0001	8	Screw, Truss Head Locking #8-32 x .25"
21	35912.1001	1	Panel w/Decals, Right Side (Includes item 22)
	01311.0003	3	Screw, Truss Head BLK #8-32 x .25"
22	37881.0000	3	Decal, No Serviceable Parts
23	35912.1004	1	Panel w/Decals, Left Side (Includes items 22 & 24)
	01311.0003	3	Screw, Truss Head BLK #8-32 x .25"
24	39318.0008	1	Schematic, Electrical
25	35916.1002	1	Panel w/Decals, Top Rear (Includes item 22)
	01311.0003	2	Screw, Truss Head BLK #8-32 x .25"

(Continued)

* Indicates the part number listed is for reference only. See DESCRIPTION for possible service replacement.

(Continued)

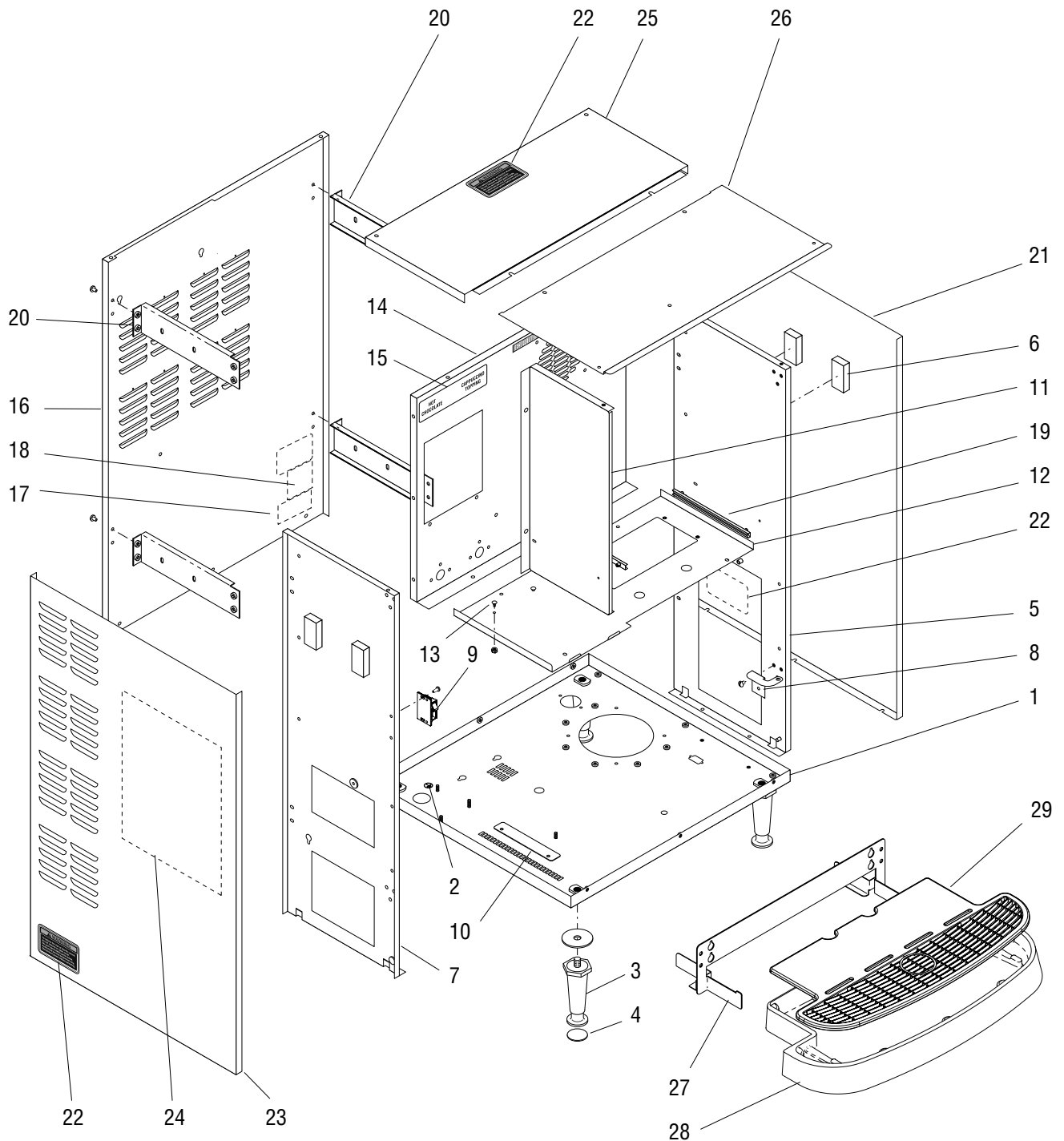

COVERS, PANELS AND DRIP TRAY

ITEM	PART NO.	QTY.	DESCRIPTION
26	35915.1002	1	Panel, Top Front
	01382.0002	2	Screw, Truss Head BLK #6-32 x .38"
	01311.0003	3	Screw, Truss Head BLK #8-32 x .25"
27	37065.0001	1	Bracket, Drip Tray
28	36670.0000	1	Drip Tray Assy
29	39308.0000	1	Cover, Drip Tray

* Indicates the part number listed is for reference only. See DESCRIPTION for possible service replacement.

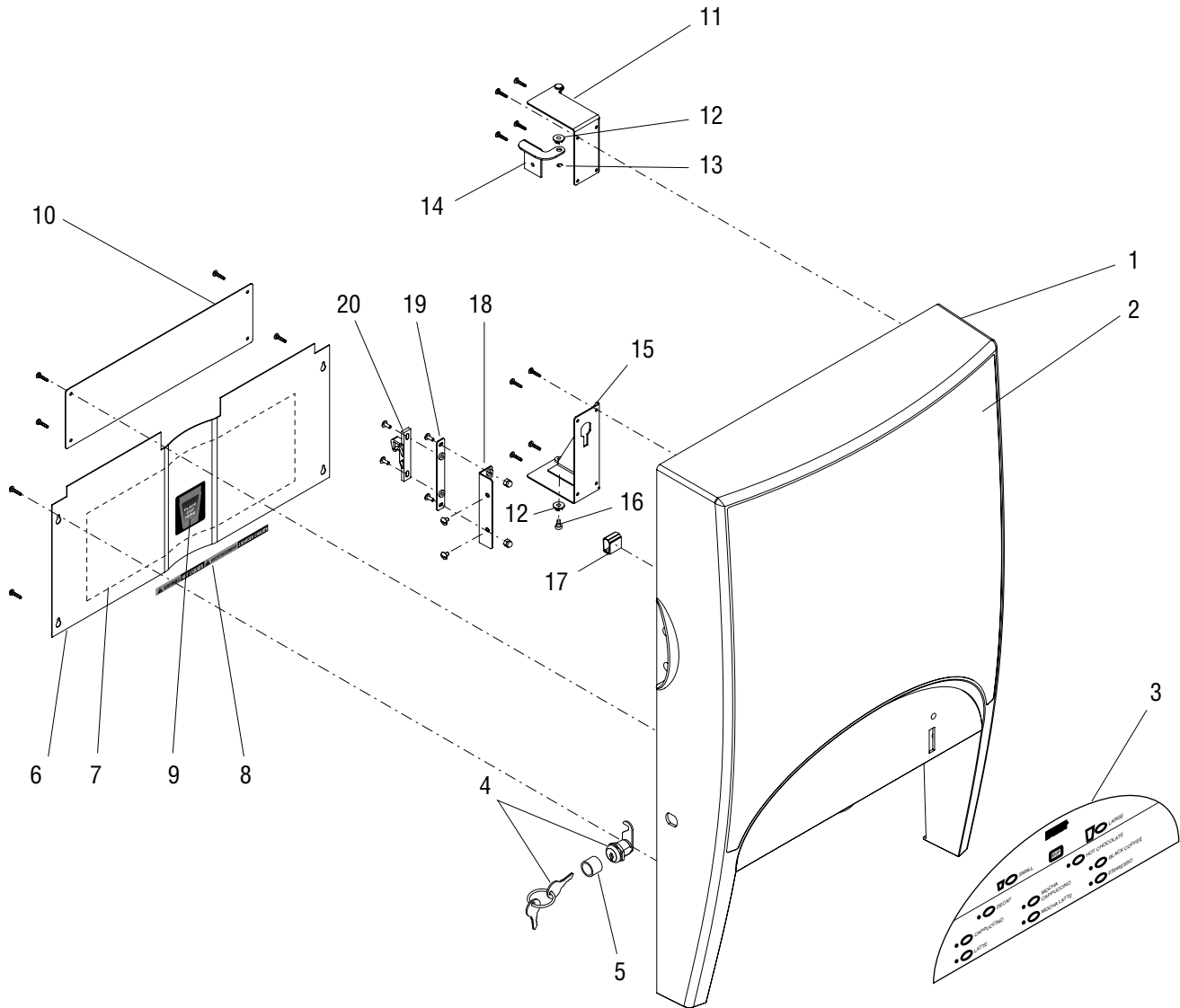

DOOR ASSEMBLY

ITEM	PART NO.	QTY.	DESCRIPTION
-	39041.1004	1	Door Assembly (Includes items 1 - 20)
1	38933.0000	1	Door
2	39167.0003	1	Decal, Door
3	39258.0007	1	Membrane Switch
4	34472.1001	1	Lock Assy (Includes Keys)
	28095.0000	1	Keys (Set of 2)
5	35052.1002	1	Tube, Silicone
6	39030.0000	1	Splash Panel
	38838.0001	4	Screw, Pan Head #6 Type 25 x .625"
7	39479.0000	1	Decal, Cleaning
8	11646.0002	1	Decal, Warning - Hot Liquids
9	39474.0000	1	Decal, Cup Placement
10	39040.1000	1	Panel, Inner Access (Includes item 21)
	38838.0001	4	Screw, Pan Head #6 Type 25 x .625"
11	39034.0000	1	Bracket, Upper Door
	38838.0001	4	Screw, Pan Head #6 Type 25 x .625"
12	34362.0000	2	Bushing
13	01403.0000	1	E-ring
14	36647.0001	1	Bracket, Hinge
	01311.0001	3	Screw, Truss Head Locking #8-32 x .25"
15	39033.0000	1	Bracket, Lower Door
	38838.0001	4	Screw, Pan Head #6 Type 25 x .625"
16	24457.0002	1	Screw, Shoulder
17	35260.0000	1	Cable Mount (Door Cable)
18	39036.0000	1	Bracket, Latch
	38838.0001	2	Screw, Pan Head #6 Type 25 x .625"
	01347.0000	2	Screw, Truss Head #6-32 x .38"
	24224.0000	2	Nut, Acorn #6-32
19	39038.0000	1	Plate, Latch
	01347.0000	2	Screw, Truss Head #6-32 x .38"
20	34667.0000	1	Keeper, Door Latch
	01311.0005	2	Screw, Truss Head BLK #8-32 x .38"

* Indicates the part number listed is for reference only. See DESCRIPTION for possible service replacement.

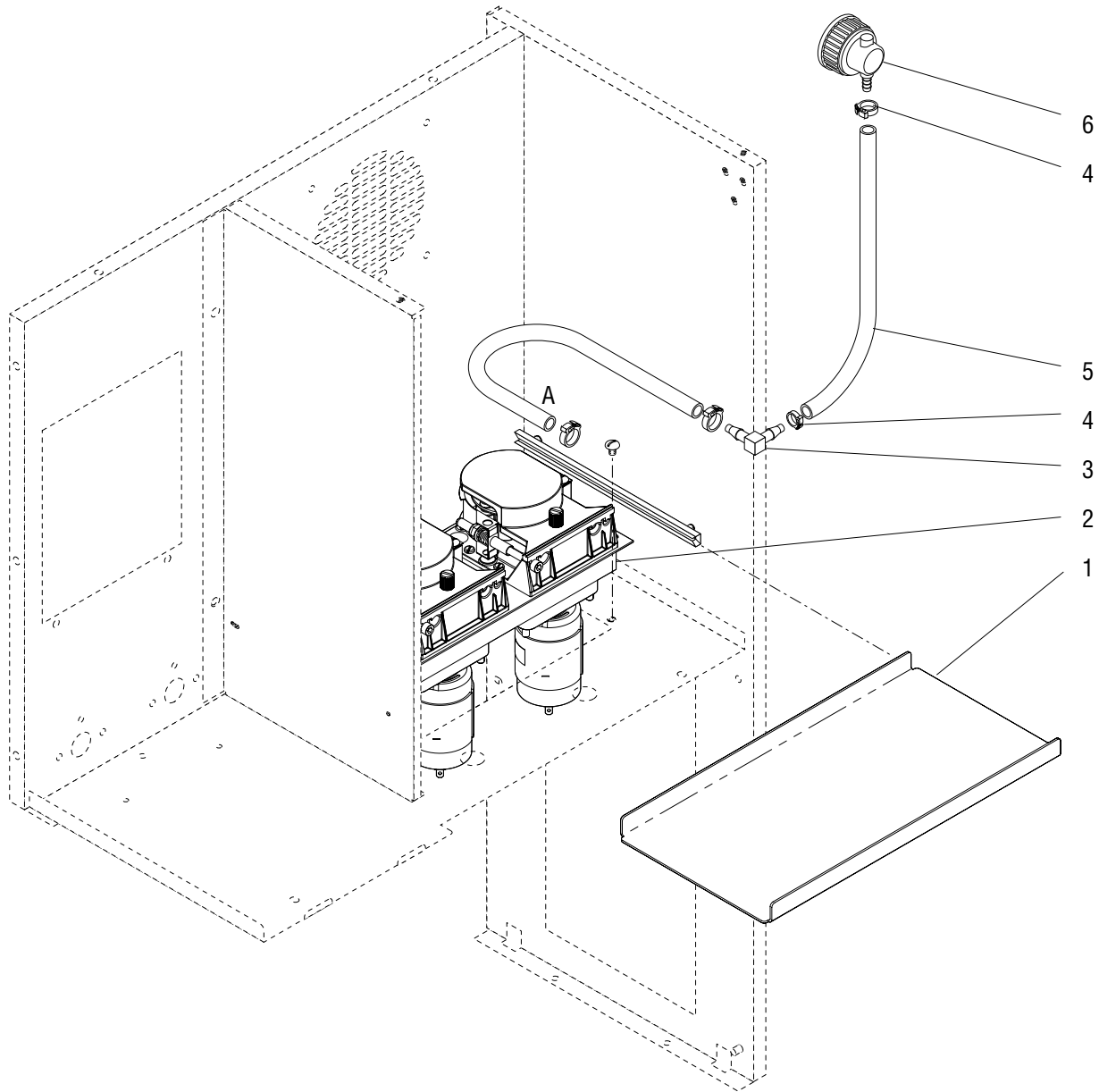

NOTE: Letters appearing within this illustration correspond to matching connections in other illustrations.

P4327.75

PUMP & TUBING

ITEM	PART NO.	QTY.	DESCRIPTION
1	45391.0000	1	Panel, BIB Support
2	----- 01311.0001	1 4	Pump Assy. (See PUMP ASSEMBLY) Screw, Truss Head #8-32 x .25" Lkg
3	34714.0000	2	Elbow, Sngl Barb
4	12422.0003	8	Clamp, Hose .34 - .39"
5	34729.0003	4	Tube, Norprene .187" ID x 9.13"
6	35057.0000	2	Connector, BIB
7	46828.1000	-	Tube Kit (Includes items 3 - 6)

* Indicates the part number listed is for reference only. See DESCRIPTION for possible service replacement.

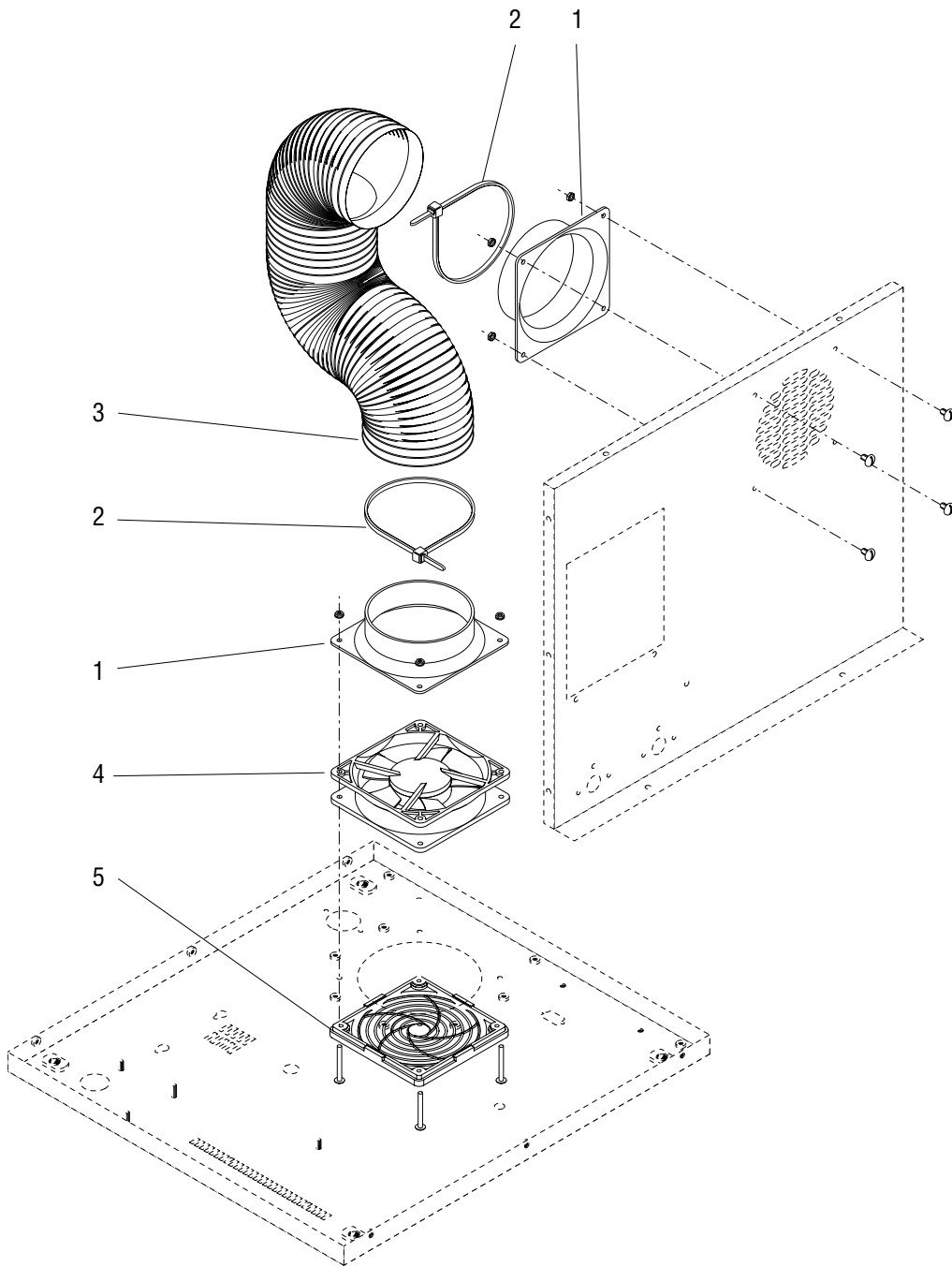

COOLING FAN & DUCT

ITEM	PART NO.	QTY.	DESCRIPTION
1	38808.0000	2	Adapter
	00970.0000	8	Nut, Keps #8-32
	01315.0000	4	Screw, Truss Head #8-32 x .38"
2	32734.0000	2	Tie, Cable
3	38811.0000	1	Duct, 4.0"
4	33297.0002	1	Fan Assy
	01384.0002	4	Screw, Truss Head #8-32 x 2.0"
5	41415.0000	1	Fan Guard

* Indicates the part number listed is for reference only. See DESCRIPTION for possible service replacement.

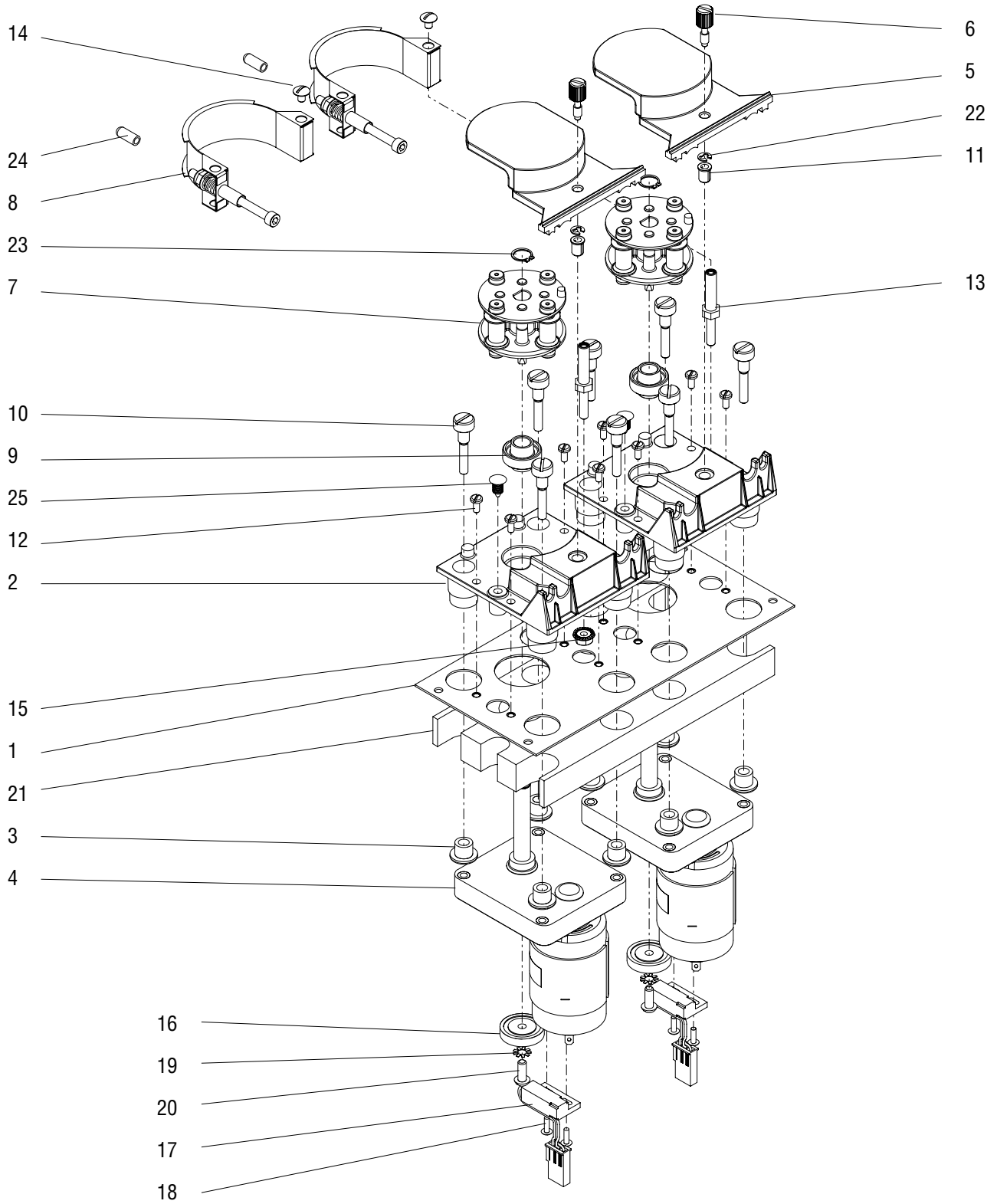

PUMP ASSEMBLY

ITEM	PART NO.	QTY.	DESCRIPTION
-	39286.1000	1	Pump Assy (Includes items 1 thru 25)
1	38683.0000	1	Bracket, Dual Pump
2	34166.1002	2	Block Assy, Pump (Includes items 9 & 11)
3	32957.0000	8	Bushing
4	34536.0001	2	Motor, Gear 24VDC
5	34167.0000	2	Cover, Pump Block
6	34997.0001	2	Screw, Captive #10-32 X .625"
7	32706.1000	2	Rotor Assy
8	40037.1000	2	Compression Band Assy.
9	33825.0000	2	Bearing, Sleeve-Pump Assy
10	32927.0000	8	Screw, Shoulder #10-32 UNF
11	32928.0000	2	Insert, Threaded #10-32
12	02328.0003	8	Screw, Pan Head #6-32 x .312"
13	32609.0000	2	Standoff, Pump Band
14	01311.0001	2	Screw, Truss Head Locking #8-32 x .25"
15	34765.0000	2	Nut, Flanged #10-32
16	32654.0000	2	Magnet Hub
17	33608.1000	2	Sensor Assy, RPM
18	02336.0000	4	Screw, Truss Head #4-40 x .38"
19	01512.0000	2	Lockwasher, Ext - tooth #10
20	01331.0004	2	Screw, Round Head Locking #10-32 x .5"
21	39293.0000	1	Insulation, Pump
22	34998.0000	2	E-ring, Retaining
23	32652.0000	2	Retaining Ring
24	12919.0009	2	Cap
25	36149.0000	2	Fastener, Snap in

* Indicates the part number listed is for reference only. See DESCRIPTION for possible service replacement.

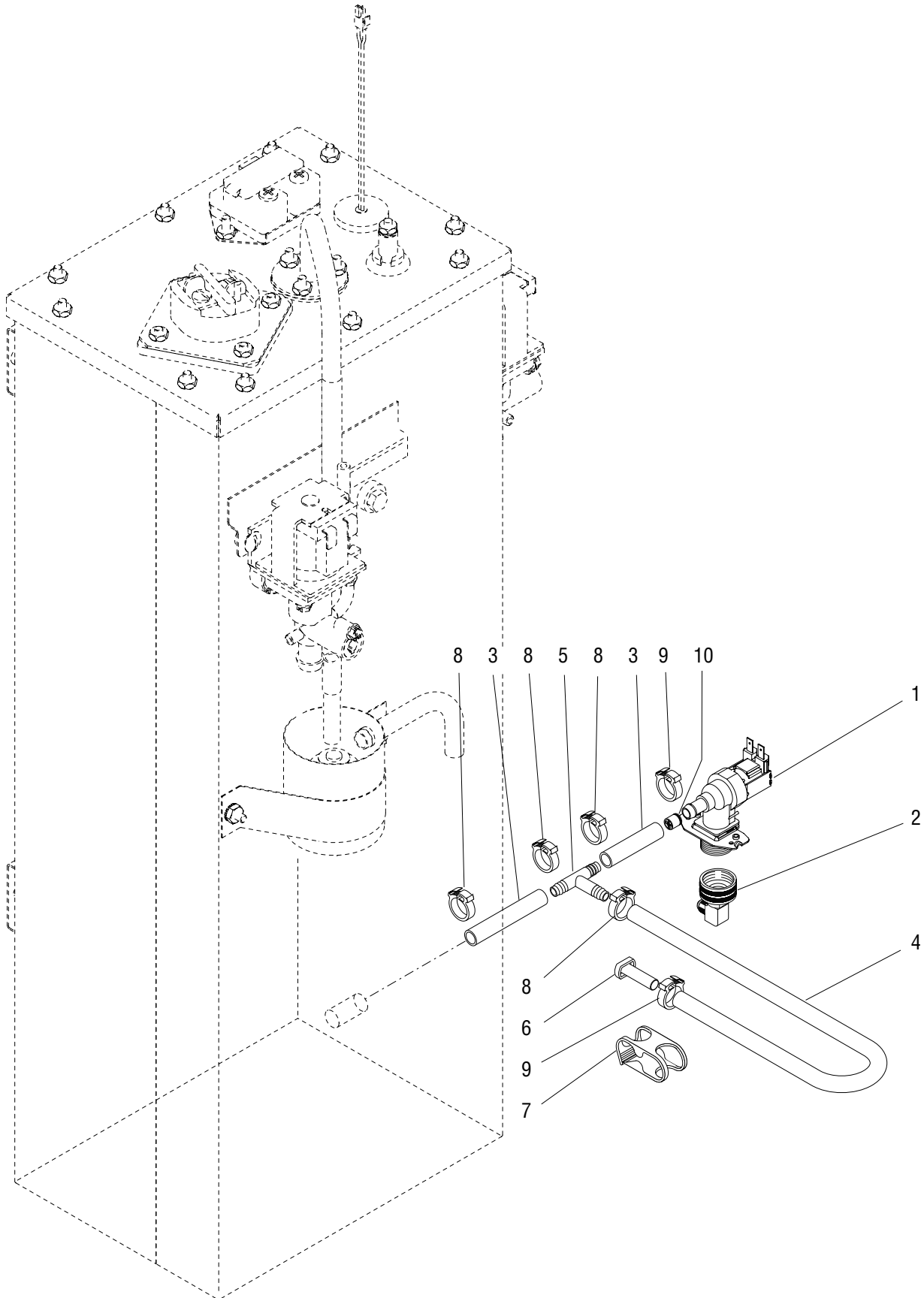

WATER INLET & TANK DRAIN

ITEM	PART NO.	QTY.	DESCRIPTION
1	40506.0004	1	Valve, Water Inlet
	32283.0000	2	Screw, Pan Head M4 x 6mm
2	37297.0006	1	Fitting, Elbow .75" x .25" Flare
3	20976.0014*	2	Tube, Silicone .38" ID x 3.25" (Order item 11)
4	20976.0000*	1	Tube, Silicone .38" ID x 30.0" (Order item 11)
5	38948.0000	1	Tee .50" Barb
6	34392.0000	1	Plug, Hose
7	11630.0001	1	Clamp, Shut Off
8	12422.0005	4	Clamp, Hose .62 - .71"
9	12422.0001	2	Clamp, Hose .59 - .66"
10	36378.0001	1	Valve, Check 2.5psi
11	20976.1000	-	Tube, Silicone .38" ID x 12.0" (Use as required)
	20976.1001	-	Tube, Silicone .38" ID x 36.0" (Use as required)
	20976.1002	-	Tube, Silicone .38" ID x 120.0" (Use as required)

* Indicates the part number listed is for reference only. See DESCRIPTION for possible service replacement.

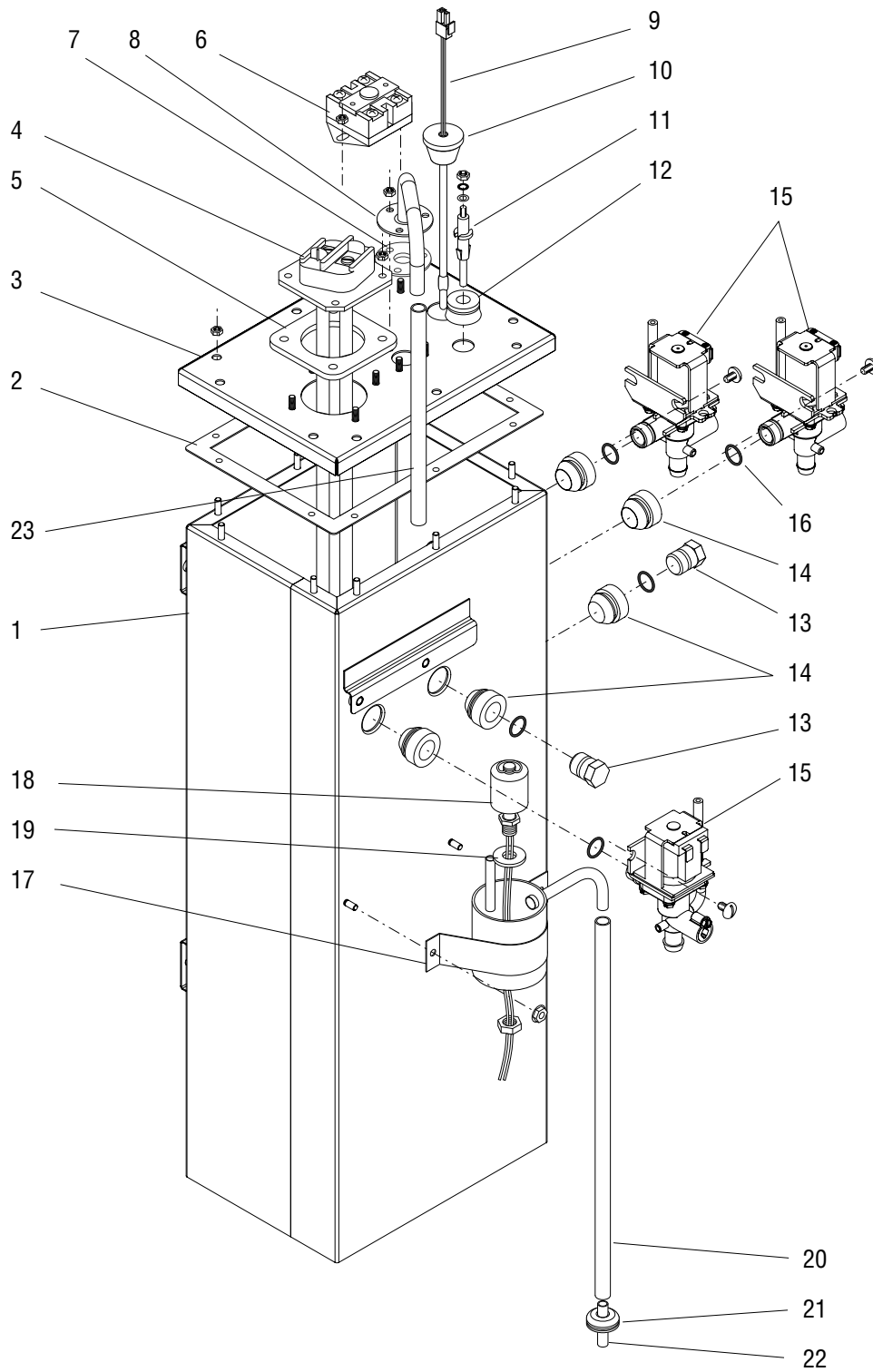

TANK ASSEMBLY

ITEM	PART NO.	QTY.	DESCRIPTION
1	37978.1002	1	Tank
	01317.0005	3	Screw, Truss Head Locking #8-32 x .38"
2	22978.0000	1	Gasket, Tank Lid
3	28281.0003	1	Lid, Tank
	00908.0000	10	Nut, Hex #8-32
4	36741.1000	1	Tank Heater 1700W (Includes item 5)
	00908.0000	4	Nut, Hex #8-32
5	12398.0002	1	Gasket, Tank Heater
6	23717.0003	1	Limit Thermostat
	00908.0000	2	Nut, Hex #8-32
7	05515.0000	1	Gasket, Overflow Tube
8	28292.0003	1	Tube, Overflow
	00908.0000	3	Nut, Hex #8-32
9	28891.1008	1	Probe, Temperature & Dry Plug
10	33801.0003	1	Grommet
11	20936.1000	1	Probe, Liquid Level (Includes hardware below)
	01501.0000	1	Washer
	20203.0100	1	Lockwasher, Internal-Tooth #8
	00908.0000	1	Nut, Hex #8-32
12	38114.0000	1	Grommet
13	26369.1000	2	Plug (Includes item 16)
14	37970.0000	5	Grommet
15	39285.1000	3	Valve Assy, Vented (Each includes item 16)
	01326.0000	3	Screw, Truss Head #10-32 x .25"
16	24733.0011	5	O-ring
17	12552.0003	1	Cup, Overflow
	00970.0000	2	Nut, Keps #8-32
18	03803.0002	1	Switch, Level (Includes item 19)
	00946.0000	1	Nut, Hex Brass
19	03633.0000	1	Gasket
20	28526.0002*	1	Tube, Silicone .38" ID x 16.0" (Order item 24)
21	02536.0000	1	Grommet
22	21801.0002	1	Tube SST
23	28526.0028*	1	Tube, Silicone .38" ID x 9.5" (Order item 24)
24	28526.1000	-	Tube, Silicone .38" ID x 12.0" (Use as required)
	28526.1001	-	Tube, Silicone .38" ID x 36.0" (Use as required)
	28526.1002	-	Tube, Silicone .38" ID x 60.0" (Use as required)
	28526.1003	-	Tube, Silicone .38" ID x 120.0" (Use as required)

* Indicates the part number listed is for reference only. See DESCRIPTION for possible service replacement.

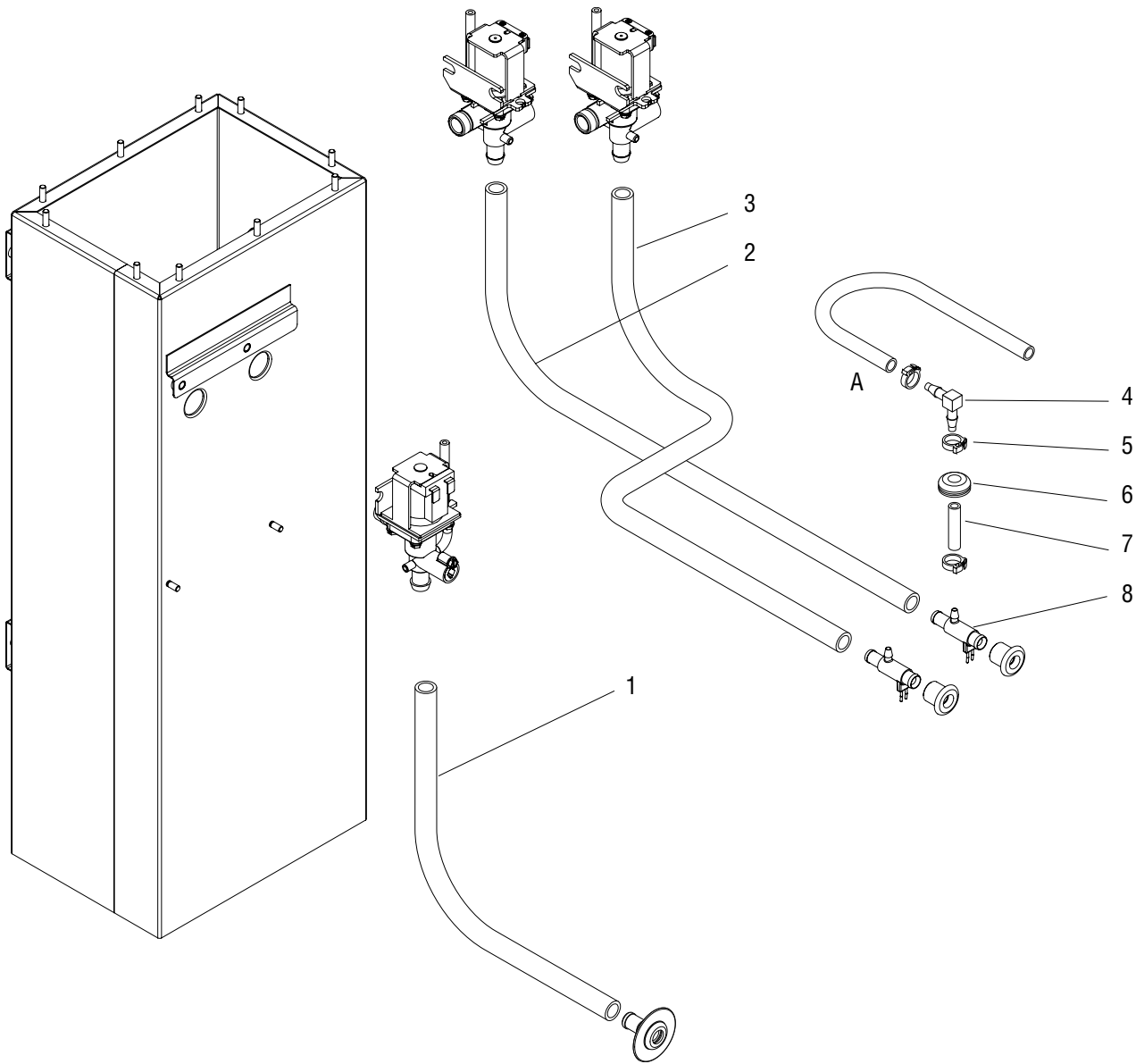

P4330.70

NOTE: Letters appearing within this illustration correspond to matching connections in other illustrations.

DISPENSE VALVES & LINES

ITEM	PART NO.	QTY.	DESCRIPTION
1	28526.0023*	1	Tube, Silicone .313" ID x 17.0" (Order item 9)
2	28526.0001*	1	Tube, Silicone .313" ID x 18.5" (Order item 9)
3	28526.0027*	1	Tube, Silicone .313" ID x 16.5" (Order item 9)
4	34714.0000	2	Elbow
5	12422.0003	4	Clamp, Hose .34 - .39"
6	02536.0000	2	Grommet
7	34729.0006*	2	Tube, Norprene .187" ID x 1.25" (Order item 10)
8	44249.0000	2	Manifold
9	28526.1000	-	Tube, Silicone .313" ID x 12.0" (Use as required)
	28526.1001	-	Tube, Silicone .313" ID x 36.0" (Use as required)
	28526.1002	-	Tube, Silicone .313" ID x 60.0" (Use as required)
	28526.1003	-	Tube, Silicone .313" ID x 120.0" (Use as required)
10	34729.1000	-	Tube, Norprene .187" ID x 8.9" (Use as required)

* Indicates the part number listed is for reference only. See DESCRIPTION for possible service replacement.

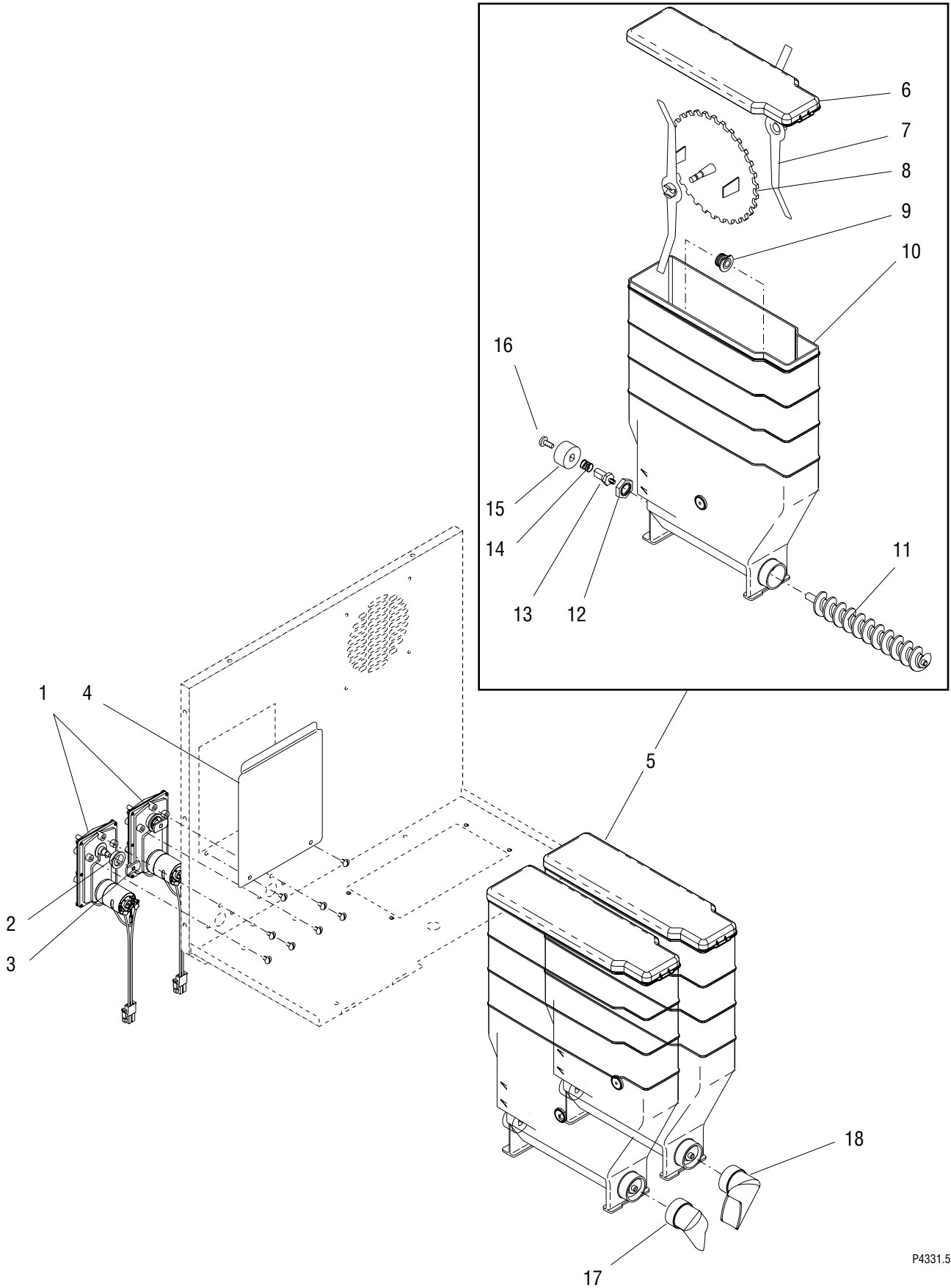

P4331.50

AUGER DRIVE & HOPPER ASSY.

ITEM	PART NO.	QTY.	DESCRIPTION
1	37037.0001	2	Gearmotor Assy (Includes items 2 & 3)
	01311.0000	6	Screw, Truss Head #8-32 x .25"
2	26401.0000	2	Dust Seal
3	36773.0000	2	Drive Plate
4	38701.0000	1	Panel, Inner Access
	01311.0000	2	Screw, Truss Head #8-32 x .25"
5	37010.1002	2	Hopper Assy (Each includes items 6 - 16)
6	36653.0001	1	Lid, Hopper
7	32337.0000	2	Mixing Blade
8	32386.0001	1	Disk, Agitator (30 Tooth)
9	28067.0000	1	Bushing, Auger Drive Shaft
10	37011.0001	1	Hopper
11	38330.0000	1	Auger
12	25743.0000	1	Locknut
13	37539.1000	1	Shaft, Hopper Drive (Includes item 16)
14	36774.0000	1	Spring
15	36770.0000	1	Coupling, Auger Drive
16	01326.0002	1	Screw, Truss Head Locking #10-32 x .312"
17	39263.0000	1	Elbow, Ejector Left
18	39263.0001	1	Elbow, Ejector Right

* Indicates the part number listed is for reference only. See DESCRIPTION for possible service replacement.

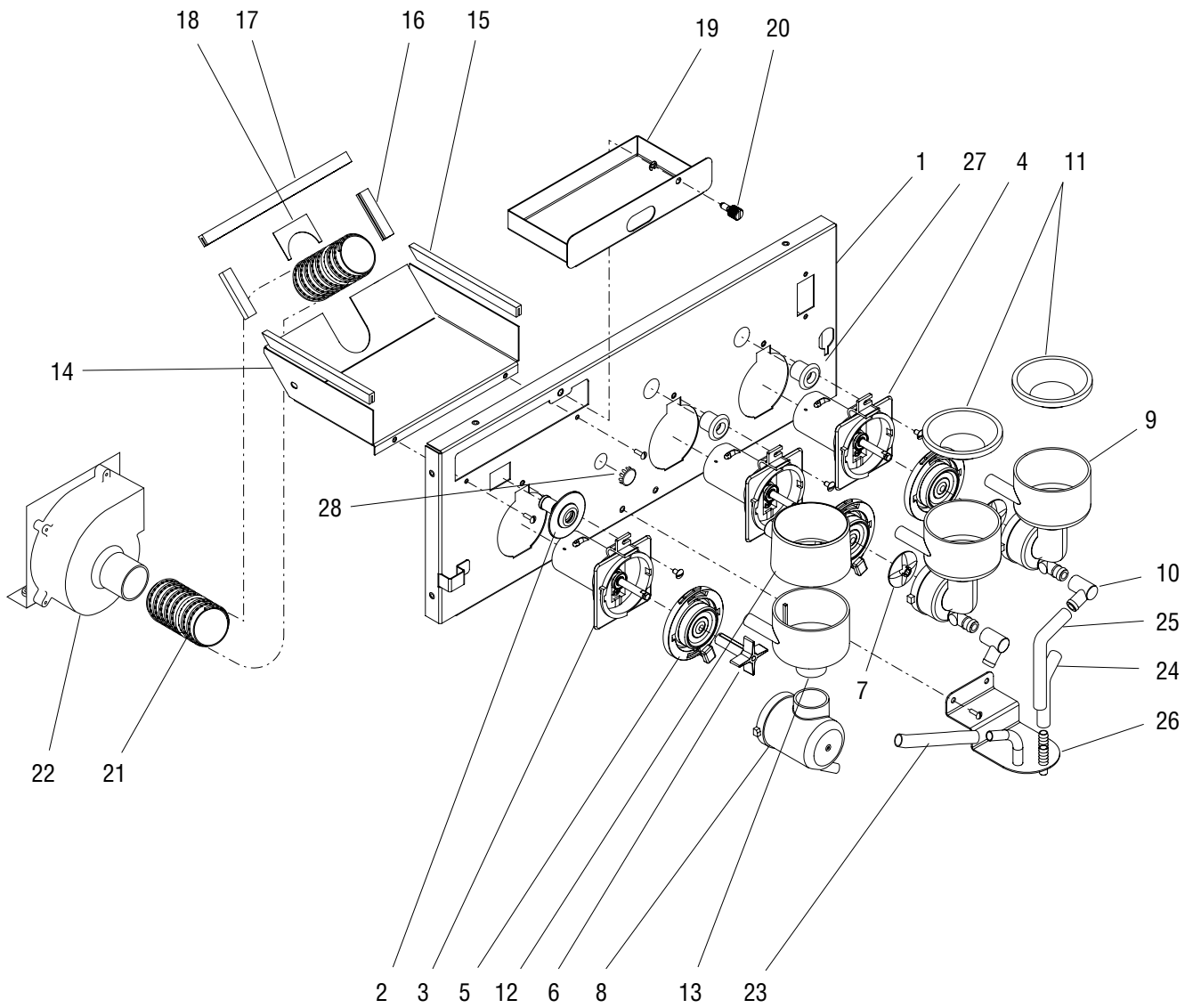

MIXING/WHIPPER CHAMBER & DRIVE MOTOR

ITEM	PART NO.	QTY.	DESCRIPTION
1	38089.0009	1	Panel, Whipper
	01311.0001	5	Screw, Truss Head Locking #8-32 x .25"
2	39315.0000	1	Fitting, Water Inlet
3	39309.0001	1	Motor, Whipper
	01308.0000	1	Screw, Truss Head #6-32 x .25"
4	39309.0000	2	Motor, Whipper
	01308.0000	2	Screw, Truss Head #6-32 x .25"
5	39313.1001	3	Base, Whipper Chamber (Includes O-ring & Shaft Seal)
6	42266.0000	1	Frother (Refer to item 31)
7	39314.0000	2	Impeller (Refer to item 31)
8	42647.0000	1	Whipper Chamber
9	39311.0000	2	Whipper Chamber
10	39312.0000	2	Fitting, Outlet
11	39552.0000	2	Trap, Condensation
12	39310.0000	1	Steam Collector
13	42281.0000	1	Mixing Bowl
14	38086.0002	1	Shelf
	02336.0000	2	Screw, Truss Head #4-40 x .38"
15	02434.0014*	2	Gasket, U-channel 4.85" (Order item 29)
16	02434.0017*	2	Gasket, U-channel 1.67" (Order item 29)
17	02434.0016*	1	Gasket, U-channel 6.50" (Order item 29)
18	38345.0000	1	Plate, Filler
19	38087.0003	1	Tray
20	37988.0000	1	Screw, Captive #10-32 x .50"
	34998.0000	1	E-ring
21	28297.0000	1	Hose, Vacuum
22	28295.0000	1	Fan, Blower
	01311.0001	2	Screw, Truss Head Locking #8-32 x .25"
23	11707.0054*	1	Tube, Silicone .25" ID x 3.25" (Order item 30)
24	11707.0046*	1	Tube, Silicone .25" ID x 2.5" (Order item 30)
25	11707.0047*	1	Tube, Silicone .25" ID x 6.5" (Order item 30)
26	38096.0003	1	Bracket, Beverage Outlet
	01311.0001	2	Screw, Truss Head Locking #8-32 x .25"

(Continued)

* Indicates the part number listed is for reference only. See DESCRIPTION for possible service replacement.

(Continued)

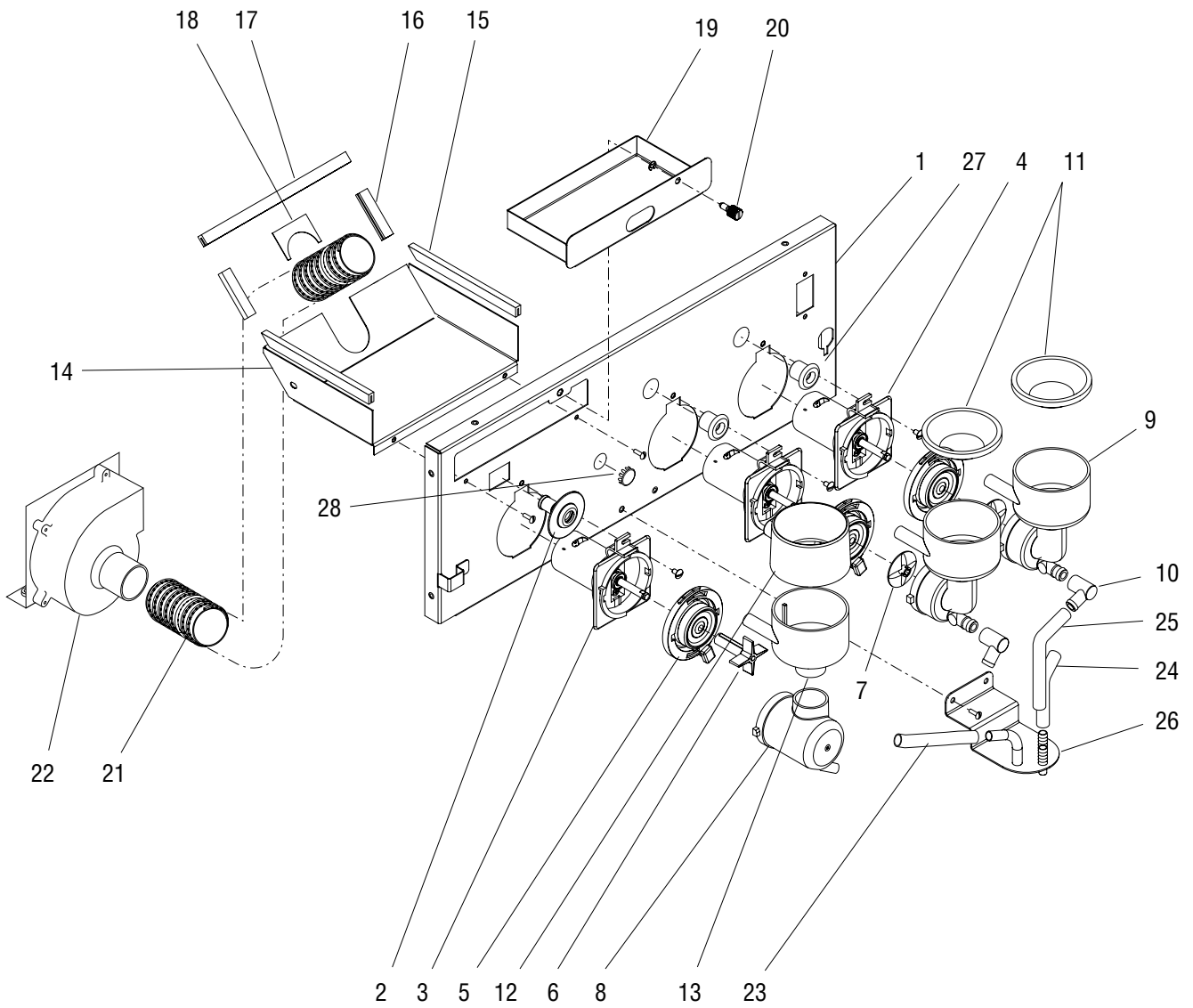

MIXING/WHIPPER CHAMBER & DRIVE MOTOR

ITEM	PART NO.	QTY.	DESCRIPTION
27	43620.0000	2	Grommet
28	00619.0009	1	Plug, Hole
29	02434.1000	-	Gasket, U-channel 18.0" (Use as required)
	02434.1001	-	Gasket, U-channel 36.0" (Use as required)
30	11707.1000	-	Tube, Silicone .25" ID x 12.0" (Use as required)
	11707.1001	-	Tube, Silicone .25" ID x 36.0" (Use as required)
	11707.1002	-	Tube, Silicone .25" ID x 120.0" (Use as required)
31	42934.0000	-	Tool, Frother Removal (Not Illustrated)

* Indicates the part number listed is for reference only. See DESCRIPTION for possible service replacement.

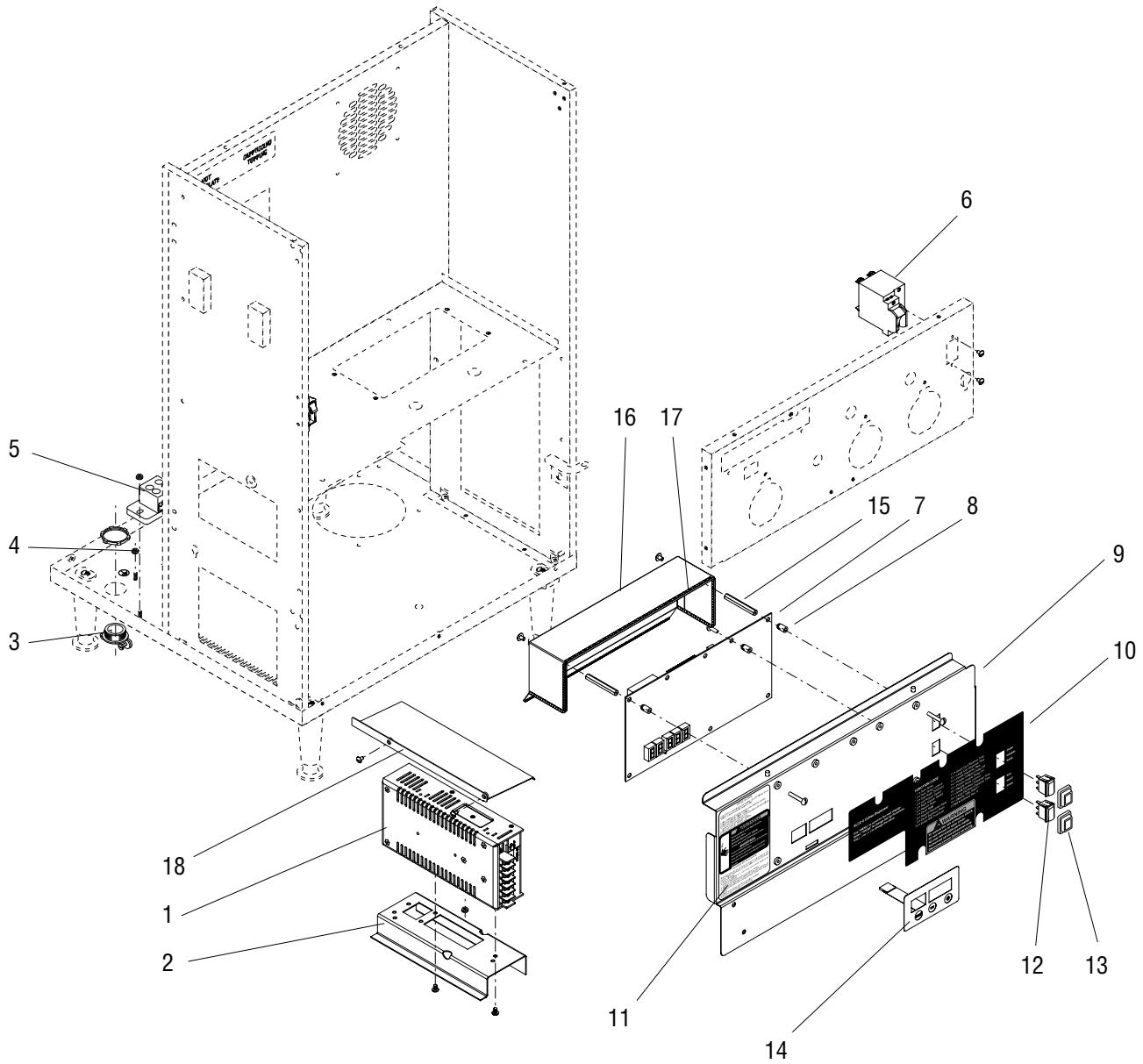

ELECTRICAL COMPONENTS

ITEM	PART NO.	QTY.	DESCRIPTION
1	33363.0004	1	Power Supply Module
	24003.0201	3	Screw, Pan Head M3 x 4mm
2	34345.0001	1	Bracket
	00970.0000	1	Nut, Keps #8-32
3	01590.0000	1	Cable Connector
4	00970.0000	1	Nut, Keps #8-32 (Grounding)
5	07038.0000	1	Terminal Block
	00970.0000	2	Nut, Keps #8-32
6	38894.0001	1	Switch
	01308.0000	2	Screw, Truss Head #6-32 x .25"
7	39044.1004	1	Circuit Board
	01390.0000	6	Screw, Round Head #8-32 x .625"
8	29081.0001	9	Spacer
9	36224.1001	1	Panel w/Decals, Lower Control (Includes items 10 & 11)
	01311.0001	2	Screw, Truss Head Locking #8-32 x .25" (Drip Tray Mounting)
	01311.0000	2	Screw, Truss Head #8-32 x .25"
10	39280.0002	1	Decal, Main Panel
11	39591.0000	1	Decal, Rinse Alarm
12	27437.0001	2	Switch
13	34390.0000	2	Cap, Rocker Switch
14	39141.0000	1	Membrane Switch
15	41851.0000	2	Stand-off, Hex #8-32
	01321.0000	2	Screw, Truss Head #8-32 x 1.0"
16	41853.1001	1	Cover (Includes item 17)
	01311.0000	2	Screw, Truss Head #8-32 x .25"
17	38278.1002	-	Edging 36"
18	42018.0000	1	Panel
	01311.0001	2	Screw, Truss Head #8-32 x .25"

The following items are not illustrated:

19	35260.0000	1	Cable Mount
20	39291.0007	1	Wiring Harness, Main
21	39292.0001	1	Wiring Harness, Door Interconnect
22	01666.0001	2	Bushing, Strain Relief (Door Harness)
23	39317.0000	1	Wiring Harness, Pumps
24	20630.0005	1	Power Cord

* Indicates the part number listed is for reference only. See DESCRIPTION for possible service replacement.

NUMERICAL INDEX

PART NO.	PAGE NO.	PART NO.	PAGE NO.	PART NO.	PAGE NO.	PART NO.	PAGE NO.
00619.0009.....	27	12552.0003.....	19	33825.0000.....	15	38278.1002.....	29
00656.0001.....	5	12919.0009.....	15	34166.1002.....	15	38330.0000.....	23
00824.0002.....	5	20203.0100.....	19	34167.0000.....	15	38345.0000.....	25
00908.0000.....	19	20630.0005.....	29	34345.0001.....	29	38664.1003.....	5
00946.0000.....	19	20936.1000.....	19	34362.0000.....	9	38683.0000.....	15
00970.0000.....	13,19,29	20960.0000.....	5	34390.0000.....	29	38701.0000.....	23
00986.0000.....	5	20976.0000.....	17	34392.0000.....	17	38808.0000.....	13
00991.0002.....	5	20976.0014.....	17	34472.1001.....	9	38811.0000.....	13
01308.0000.....	25,29	20976.1000.....	17	34536.0001.....	15	38838.0001.....	9
01311.0000.....	5,23,29	20976.1001.....	17	34666.0000.....	5	38894.0001.....	29
01311.0001.....	5,9,11,15,25,29	20976.1002.....	17	34667.0000.....	9	38933.0000.....	9
01311.0003.....	5,7	21801.0002.....	19	34714.0000.....	11,21	38948.0000.....	17
01311.0005.....	9	22978.0000.....	19	34729.0003.....	11	38990.1001.....	5
01315.0000.....	13	23717.0003.....	19	34729.0006.....	21	39030.0000.....	9
01317.0005.....	19	24003.0201.....	29	34729.1000.....	21	39033.0000.....	9
01321.0000.....	29	24224.0000.....	9	34765.0000.....	15	39034.0000.....	9
01326.0000.....	19	24457.0002.....	9	34997.0001.....	15	39036.0000.....	9
01326.0002.....	23	24733.0011.....	19	34998.0000.....	15,25	39038.0000.....	9
01331.0004.....	15	25743.0000.....	23	35052.1002.....	9	39040.1000.....	9
01347.0000.....	9	26008.0001.....	5	35057.0000.....	11	39041.1004.....	9
01382.0002.....	7	26369.1000.....	19	35260.0000.....	9,29	39044.1004.....	29
01384.0002.....	13	26401.0000.....	23	35912.1001.....	5	39141.0000.....	29
01390.0000.....	29	26528.0000.....	5	35912.1004.....	5	39167.0003.....	9
01403.0000.....	9	27437.0001.....	29	35915.1002.....	7	39258.0007.....	9
01501.0000.....	19	28067.0000.....	23	35916.1002.....	5	39263.0000.....	23
01509.0001.....	5	28095.0000.....	9	35926.0000.....	5	39263.0001.....	23
01512.0000.....	15	28281.0003.....	19	36149.0000.....	15	39280.0002.....	29
01526.0001.....	5	28292.0003.....	19	36224.1001.....	29	39284.0000.....	5
01590.0000.....	29	28295.0000.....	25	36378.0001.....	17	39285.1000.....	19
01666.0001.....	29	28297.0000.....	25	36647.0001.....	5,9	39286.1000.....	15
02328.0003.....	15	28526.0001.....	21	36653.0001.....	23	39291.0007.....	29
02336.0000.....	5,15	28526.0002.....	19	36670.0000.....	7	39292.0001.....	29
02336.0000.....	25	28526.0023.....	21	36741.1000.....	19	39293.0000.....	15
02434.0014.....	25	28526.0027.....	21	36770.0000.....	23	39308.0000.....	7
02434.0016.....	25	28526.0028.....	19	36773.0000.....	23	39309.0000.....	25
02434.0017.....	25	28526.1000.....	19,21	36774.0000.....	23	39309.0001.....	25
02434.1000.....	27	28526.1001.....	19,21	36896.0000.....	5	39310.0000.....	25
02434.1001.....	27	28526.1002.....	19,21	37010.1002.....	23	39311.0000.....	25
02536.0000.....	19,21	28526.1003.....	19,21	37011.0001.....	23	39312.0000.....	25
03633.0000.....	19	28891.1008.....	19	37037.0001.....	23	39313.1001.....	25
03803.0002.....	19	29081.0001.....	29	37065.0001.....	7	39314.0000.....	25
03996.0000.....	5	32283.0000.....	17	37297.0006.....	17	39315.0000.....	25
05515.0000.....	19	32337.0000.....	23	37539.1000.....	23	39317.0000.....	29
07038.0000.....	29	32386.0001.....	23	37881.0000.....	5	39318.0008.....	5
11630.0001.....	17	32609.0000.....	15	37970.0000.....	19	39474.0000.....	9
11646.0002.....	9	32652.0000.....	15	37978.1002.....	19	39479.0000.....	9
11707.0046.....	25	32654.0000.....	15	37988.0000.....	25	39552.0000.....	25
11707.0047.....	25	32706.1000.....	15	38077.1006.....	5	39583.0000.....	5
11707.0054.....	25	32734.0000.....	13	38080.0001.....	5	39591.0000.....	29
11707.1000.....	27	32927.0000.....	15	38082.0000.....	5	40037.1000.....	15
11707.1001.....	27	32928.0000.....	15	38084.0003.....	5	40506.0004.....	17
11707.1002.....	27	32957.0000.....	15	38086.0002.....	25	41415.0000.....	13
12398.0002.....	19	33297.0002.....	13	38087.0003.....	25	41851.0000.....	29
12422.0001.....	17	33363.0004.....	29	38089.0009.....	25	41853.1001.....	29
12422.0003.....	11,21	33608.1000.....	15	38096.0003.....	25	42018.0000.....	29
12422.0005.....	17	33801.0003.....	19	38114.0000.....	19	42266.0000.....	25

NUMERICAL INDEX

PART NO.	PAGE NO.	PART NO.	PAGE NO.	PART NO.	PAGE NO.	PART NO.	PAGE NO.
42281.0000.....	25						
42647.0000.....	25						
42934.0000.....	27						
43620.0000.....	27						
44249.0000.....	21						
45389.0000.....	5						
45391.0000.....	11						
46828.1000.....	11						