

# BUNN®

# TCD-1/2



## INSTALLATION & OPERATING GUIDE With ILLUSTRATED PARTS

**NOTE: LIFT THE DISPENSER USING THE HANDLES ONLY. DO NOT LIFT THE DISPENSER FROM THE BOTTOM.**

### **BUNN-O-MATIC CORPORATION**

POST OFFICE BOX 3227

SPRINGFIELD, ILLINOIS 62708-3227

PHONE: (217) 529-6601 FAX: (217) 529-6644

To ensure you have the latest revision of the Operating Manual, or to view the Illustrated Parts Catalog, Programming Manual, or Service Manual, please visit the Bunn-O-Matic website, at [www.bunn.com](http://www.bunn.com). This is absolutely FREE, and the quickest way to obtain the latest catalog and manual updates. For Technical Service, contact Bunn-O-Matic Corporation at 1-800-286-6070.



## BUNN-O-MATIC COMMERCIAL PRODUCT WARRANTY

Bunn-O-Matic Corp. ("BUNN") warrants equipment manufactured by it as follows:

- 1) Airpots, thermal carafes, decanters, GPR servers, iced tea/coffee dispensers, MCR/MCP/MCA single cup brewers, thermal servers and ThermoFresh® servers (mechanical and digital) 1 year parts and 1 year labor.
- 2) All other equipment - 2 years parts and 1 year labor plus added warranties as specified below:
  - a) Electronic circuit and/or control boards - parts and labor for 3 years.
  - b) Compressors on refrigeration equipment - 5 years parts and 1 year labor.
  - c) Grinding burrs on coffee grinding equipment to grind coffee to meet original factory screen sieve analysis - parts and labor for 4 years or 40,000 pounds of coffee, whichever comes first.

These warranty periods run from the date of installation BUNN warrants that the equipment manufactured by it will be commercially free of defects in material and workmanship existing at the time of manufacture and appearing within the applicable warranty period. This warranty does not apply to any equipment, component or part that was not manufactured by BUNN or that, in BUNN's judgment, has been affected by misuse, neglect, alteration, improper installation or operation, improper maintenance or repair, non periodic cleaning and descaling, equipment failures related to poor water quality, damage or casualty. In addition, the warranty does not apply to replacement of items subject to normal use including but not limited to user replaceable parts such as seals and gaskets. This warranty is conditioned on the Buyer 1) giving BUNN prompt notice of any claim to be made under this warranty by telephone at (217) 529-6601 or by writing to Post Office Box 3227, Springfield, Illinois 62708-3227; 2) if requested by BUNN, shipping the defective equipment prepaid to an authorized BUNN service location; and 3) receiving prior authorization from BUNN that the defective equipment is under warranty.

**THE FOREGOING WARRANTY IS EXCLUSIVE AND IS IN LIEU OF ANY OTHER WARRANTY, WRITTEN OR ORAL, EXPRESS OR IMPLIED, INCLUDING, BUT NOT LIMITED TO, ANY IMPLIED WARRANTY OF EITHER MERCHANTABILITY OR FITNESS FOR A PARTICULAR PURPOSE.** The agents, dealers or employees of BUNN are not authorized to make modifications to this warranty or to make additional warranties that are binding on BUNN. Accordingly, statements by such individuals, whether oral or written, do not constitute warranties and should not be relied upon.

If BUNN determines in its sole discretion that the equipment does not conform to the warranty, BUNN, at its exclusive option while the equipment is under warranty, shall either 1) provide at no charge replacement parts and/or labor (during the applicable parts and labor warranty periods specified above) to repair the defective components, provided that this repair is done by a BUNN Authorized Service Representative; or 2) shall replace the equipment or refund the purchase price for the equipment.

**THE BUYER'S REMEDY AGAINST BUNN FOR THE BREACH OF ANY OBLIGATION ARISING OUT OF THE SALE OF THIS EQUIPMENT, WHETHER DERIVED FROM WARRANTY OR OTHERWISE, SHALL BE LIMITED, AT BUNN'S SOLE OPTION AS SPECIFIED HEREIN, TO REPAIR, REPLACEMENT OR REFUND.**

In no event shall BUNN be liable for any other damage or loss, including, but not limited to, lost profits, lost sales, loss of use of equipment, claims of Buyer's customers, cost of capital, cost of down time, cost of substitute equipment, facilities or services, or any other special, incidental or consequential damages.

392, A Partner You Can Count On, Air Infusion, AutoPOD, AXIOM, BrewLOGIC, BrewMETER, Brew Better Not Bitter, BrewWISE, BrewWIZARD, BUNN Espresso, BUNN Family Gourmet, BUNN Gourmet, BUNN Pour-O-Matic, BUNN, BUNN with the stylized red line, BUNNlink, Bunn-O-Matic, Bunn-O-Matic, BUNNserve, BUNNSERVE with the stylized wrench design, Cool Froth, DBC, Dr. Brew stylized Dr. design, Dual, Easy Pour, EasyClear, EasyGard, FlavorGard, Gourmet Ice, Gourmet Juice, High Intensity, iMIX, Infusion Series, Intellisteam, My Café, Phase Brew, PowerLogic, Quality Beverage Equipment Worldwide, Respect Earth, Respect Earth with the stylized leaf and coffee cherry design, Safety-Fresh, savemycoffee.com, Scale-Pro, Silver Series, Single, Smart Funnel, Smart Hopper, SmartWAVE, Soft Heat, SplashGard, The Mark of Quality in Beverage Equipment Worldwide, ThermoFresh, Titan, trifacta, TRIFECTA (stylized logo), Velocity Brew, Air Brew, Beverage Bar Creator, Beverage Profit Calculator, Brew better, not bitter., Build-A-Drink, BUNNSource, Coffee At Its Best, Cyclonic Heating System, Daypart, Digital Brewer Control, Element, Milk Texturing Fusion, Nothing Brews Like a BUNN, Picture Prompted Cleaning, Pouring Profits, Signature Series, Sure Tamp, Tea At Its Best, The Horizontal Red Line, Ultra are either trademarks or registered trademarks of Bunn-O-Matic Corporation. The commercial trifacta® brewer housing configuration is a trademark of Bunn-O-Matic Corporation.

## INTRODUCTION

These dispensers are designed to mix liquid tea concentrate with water to produce iced tea by the glass or pitcher. The concentrate can be stored either inside the dispenser, or outside with a hose connection to the dispenser. The dispenser must be placed on a sturdy counter or shelf.

## PLUMBING REQUIREMENTS

This dispenser must be connected to a cold water system with operating pressure between 30 and 90 psi (0.138 and 0.620 MPa) from a 1/2" or larger supply line. A shut-off valve should be installed in the line before the dispenser. The water inlet fitting is 1/4" flare.

**NOTE** - Bunn-O-Matic recommends 1/4" copper (or 3/8" braided flex) tubing for all installations from the 1/2" water supply line. A tight coil of copper tubing in the water line will facilitate moving the dispenser to clean the counter top. Bunn-O-Matic does not recommend the use of a saddle valve to install the dispenser. The size and shape of the hole made in the supply line by this type of device may restrict water flow.

**As directed in the International Plumbing Code of the International Code Council and the Food Code Manual of the Food and Drug Administration (FDA), this equipment must be installed with adequate backflow prevention to comply with federal, state and local codes. For models installed outside the U.S.A., you must comply with the applicable Plumbing /Sanitation Code for your area.**

## USER NOTICES

Carefully read and follow all notices in this manual and on the equipment. All labels on the equipment should be kept in good condition. Replace any unreadable or damaged labels.

**As directed in the International Plumbing Code of the International Code Council and the Food Code Manual of the Food and Drug Administration (FDA), this equipment must be installed with adequate backflow prevention to comply with federal, state and local codes. For models installed outside the U.S.A., you must comply with the applicable Plumbing /Sanitation Code for your area.**

00656.0001

### PRESSURE REGULATOR ADJUSTMENT

1. Pull Knob out to unlock.
2. Adjust to 20 psi while faucet is open, dispensing product.
3. Push knob in to lock.

38465.0000



## WARNING

### FAUCET UNDER PRESSURE

Shut off water before cleaning. Use only BUNN approved faucet part #03260.0004 (Plastic Body Faucet, Locking Handle), #03260.0009 (Plastic Body Faucet, Non-Locking Handle) or #03260.0005 (Chrome Body Faucet), specifically designed for this equipment. Close the water valve at night or when not in use.

38130.0000

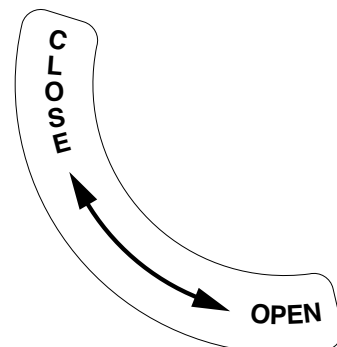

38466.0000

## SET UP AND OPERATING PROCEDURES

1. Remove dispenser from the box and place on a sturdy, level counter.
2. Remove the brass cap and any packing material from the end of the water inlet fitting located on the rear of the dispenser.
3. Attach a 1/4" water line to the inlet fitting. This supply line must have at least 30 psi of pressure.
4. Using a screwdriver, turn the adjustment screw on the venturi mixer clockwise until the screw contacts the seat (DO NOT OVERTIGHTEN THIS SCREW!).
5. Turn on the water supply and open the water inlet valve on the rear of the dispenser and check for leaks in the system.
6. Place a container under faucet(s); fully open the faucet(s) for approximately 10 seconds to remove all the air out of the lines, then close the faucet(s). Discard the water.
7. Connect the proper BIB (Bag in a Box) adapter(s) to the concentrate inlet tube(s) and clamp. If bottle concentrate is used, connect the stainless formed tube(s) to the inlet hose(s) and clamp.
8. Attach the connector(s) to the BIB, or insert the bottle adapter into the bottle(s).
9. Place the concentrate container(s) in the location they will be used for normal operations.
  - a. In the dispenser housing: Coil the tube in the dispenser and place the BIB (bottle) on top of the coiled tubing with the connector facing down, under the bag.
  - b. Under the counter: Place the BIB under the counter and rout the tubing to the dispenser, avoiding sharp bends and kinks. Cut off excess tubing to keep the over length of tubing to minimum.

**NOTE:** It is critical that the dispenser is upright and the concentrate container(s) be in the proper location and orientation that they will be during normal operation, before making any strength adjustments.

10. Slide the dispenser to the edge of the counter to gain access to the adjustment screw from the bottom.
11. Turn the adjustment screw approximately 1/2 turn counterclockwise.
12. Place a container under the faucet(s) and open faucet(s) until the entire concentrate line(s) fill and tea is dispensed for approximately 5 seconds. Close the faucet(s). Discard this solution.
13. Place a glass under the faucet and open to fill the glass. Adjust the screw to achieve the desired strength of tea. To increase the amount of concentrate (stronger tea), turn the adjustment screw counterclockwise slightly (1/16 to 1/8 of a turn at a time). To reduce the amount of concentrate (weaker tea), turn the adjustment screw clockwise slightly (1/16 to 1/8 of a turn at a time).
14. Dispense a couple of 8 ounce glasses of tea after each adjustment and test for taste or color. Continue this process until the taste or color profile is achieved.

**NOTE:** The ratio adjustment setting is very sensitive. Make very small adjustments with the screw, then taste or color check the results. You do not have to turn the screw very much to change the ratio.

15. Once the desired ratio of concentrate to water has been set, slide the dispenser back to the desired location on the counter top. For under counter BIB's, make sure the tubes do not get kinked, when the dispenser is slid back into place.

The dispenser is now ready for use.

## DISPENSER CLEANING AND SANITIZING

### Daily Cleaning:

1. Turn handle on rear of dispenser to shut off the water supply.
2. Open the faucet to relieve pressure in the system.
3. Since the bag connector(s) have an internal shut off valve, it will be necessary to prop the valve open during cleaning.

NOTE: Cutting off the mating connector of an empty concentrate bag works well for this. Keep this mating end for future cleanings of the system.

4. Turn on water supply to the dispenser.
5. Place the open bag connector into a 1/2 gallon container of dish soap and warm to hot water (130° F/54° C).
6. Place a large container under dispenser faucet.
7. Open faucet until the soap/water mixture in the container is empty.
8. After the soap mixture has been flushed through the system, fill the container with warm to hot tap water only (no soap) and repeat steps 5 thru 7 until all soap has been flushed from the system.
9. Remove the mating end of connector and attach dispenser's connector to a Bag In a Box and dispense several cups to prime the concentrate line or until consistency of the product is correct.
10. Wash the entire outside surface of dispenser with a clean, damp cloth.

NOTE: When the system is not in use for extended periods of time (nights, weekends, etc.), turn the water supply valve off.

### Weekly Cleaning:

1. Turn handle on rear of dispenser to shut off the water supply.
2. Open the faucet to relieve pressure in the system.

On models with chrome nut (Complete Step 3, then skip to Step 6):

On models with wing nut (Skip Step 3 - Start at Step 4):

3. Unscrew the faucet bonnet (a) and remove all faucet components, leaving the faucet body (b) in place on the venturi assembly.
4. Twist the faucet wing nut in a clockwise direction and remove faucet from the dispenser.
5. Remove and clean the O-ring (Optional).

- a. Remove the o-ring from the venturi assembly nozzle. Be very careful when removing this o-ring. Do Not scratch or nick the o-rings sealing surface when removing.
- b. Clean the groove and o-ring with the same solutions as used to clean the faucet, Step 6.
- c. When finished, slide the o-ring back into the groove on the venturi nozzle.

6. Sanitizing the faucet:

This procedure requires three cleaning solutions of approximately ½ gal each, a mild detergent and warm water solution, clean hot water only and a warm chlorine solution (at least 50 ppm of chlorine at 75° F [24° C]). NOTE: DO NOT use full strength bleach.

- a. Disassemble the faucet.
- b. Thoroughly wash all faucet parts in the mild detergent solution.
- c. Rinse the parts in hot water.
- d. Sanitize the parts by soaking for one minute in the warm chlorine solution.
- e. Re-rinse the parts in hot water to remove all the chlorine solution.
- f. Reassemble the faucet and attach it to the dispenser.

7. Sanitizing the BIB connector, tubing and metering valve:

This procedure requires a 1/2 gallon container of sanitizing solution, (100 ppm of chlorine at 100° F (38° C) water).

- a. Since the bag connector(s) have an internal shut off valve, it will be necessary to prop the valve open during cleaning. NOTE: Cutting off the mating connector of an empty concentrate bag works well for this. Keep this mating end for future cleanings of the system.
  - b. Turn on water supply to the dispenser.
  - c. Place open bag connector into the 1/2 gallon container of sanitizing solution.
  - d. Place a large container under dispenser faucet.
  - e. Open faucet until the chlorine mixture in the container is empty.
  - f. Allow dispenser to sit overnight before flushing sanitizer out of the system.
  - g. Flush system by filling a container with warm to hot tap water only (no chlorine) and opening the faucet - until all chlorine has been flushed from the system.
8. Remove the mating end of connector and attach dispenser's connector to a Bag In a Box and dispense several cups to prime the concentrate line or until consistency of the product is correct.

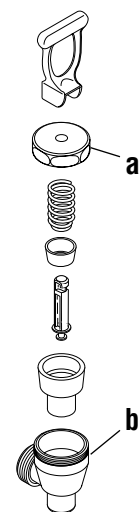

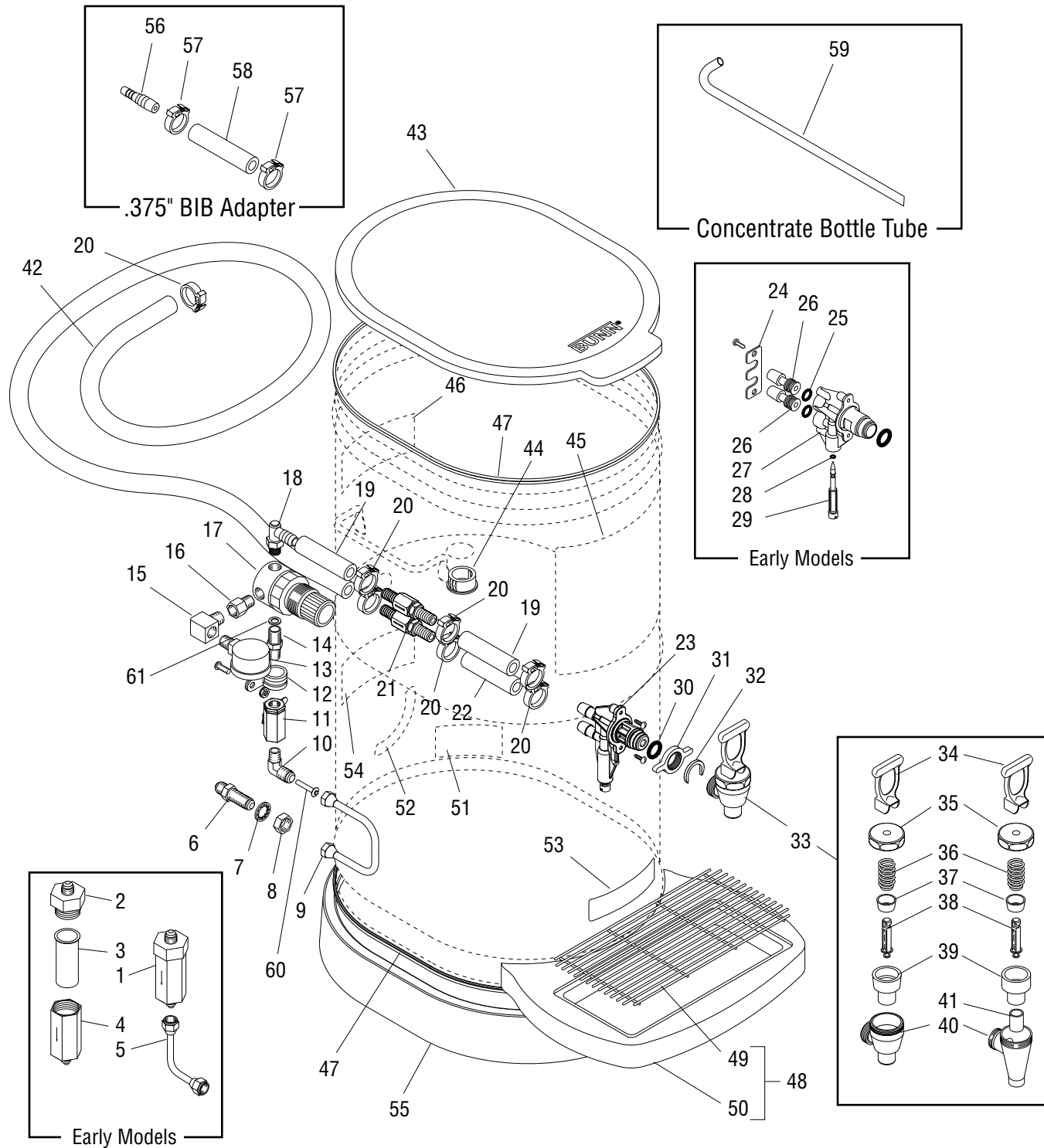

## REPLACEMENT PARTS (TCD-1)

ITEM	PART NO.	QTY.	DESCRIPTION	
<b>NOTE: Effective August 2006, the Venturi and product delivery tubing was changed from .25"ID to .375"ID to improve flow rate. If for first replacement, order Tube Replacement Kit P/N 39169.0000 (2 kits required for TCD-2)</b>				
1	23820.1000	1	Water Strainer Assy (Includes items 2 thru 4)	} Early Models
2	22249.0000	1	Cap, Water Strainer	
3	23721.0000	1	Screen	
4	23819.0000*	1	Housing (Order item 1)	
5	00310.0006	1	Tube Assy, Strainer to Bulkhead	
6	00459.0001	1	Fitting, Bulkhead	
7	01532.0000	1	Lockwasher, Internal Tooth .438"	
8	00463.0000	1	Nut, .438" - 20	
9	37689.0000	1	Tube Assy, Bulkhead to Shut-off	
10	32891.0001	1	Elbow, Male .25" FLR x .25" MPT	
11	33113.0000	1	Valve, Ball .25" FPT x .25" FPT	
12	32360.0001	1	Clamp, .613" ID	
	01315.0000	1	Screw, Truss Head #8-32 x .375"	
	00991.0000	1	Nut #8-32	
13	37898.0000	1	Gauge, Pressure	
14	37742.0001	1	Nipple, .25" MPT	
15	00432.0001	1	Elbow, .125" NPT Male/Female	
16	00430.0001	1	Adapter, .125" NPT Male/Female	
17	21993.0005	1	Regulator, Water, Low Flow (TCD models except 37750.0037 & 37750.0038)	
	21993.0006	1	Regulator, Water, Low Flow (TCD models 37750.0037 & 37750.0038 only)	
18	37460.0000	1	Fitting, Barb Elbow .25" NPT	
19	37720.0001*	2	Tube, Silicone .375" ID x 5.25" (Order item 64)	
20	12422.0001	8	Clamp, Hose .59"/.66"	
21	40071.0001	2	Valve, Check .375" Barb	
22	37720.0004*	1	Tube, Silicone .375" ID x 1.75" (Order item 64)	
23	37736.1000	1	Venturi Assy (.25" product tubing)(Includes item 24,25, 27-29 & 32)	} Early Models
	37736.1001	1	Venturi Assy (.375" product tubing)(Includes item 24 thru 29 & 32)	
	37736.1002	1	Venturi Assy w/Barbs (.375" tubing)(Includes item 28, 29 & 30)(Late Models)	
	38044.0000	2	Screw, Plastite #6 x .375"	
24	43111.0000	1	Plate, Fitting Retainer	
	01360.0002	2	Screw, Plascrew #6 x .375"	
25	32849.0001	2	O-ring	
26	32631.1002	2	Fitting, Barb .375"	

(continued)

\* Indicates the part number listed is for reference only. See DESCRIPTION for possible service replacement.

(continued)

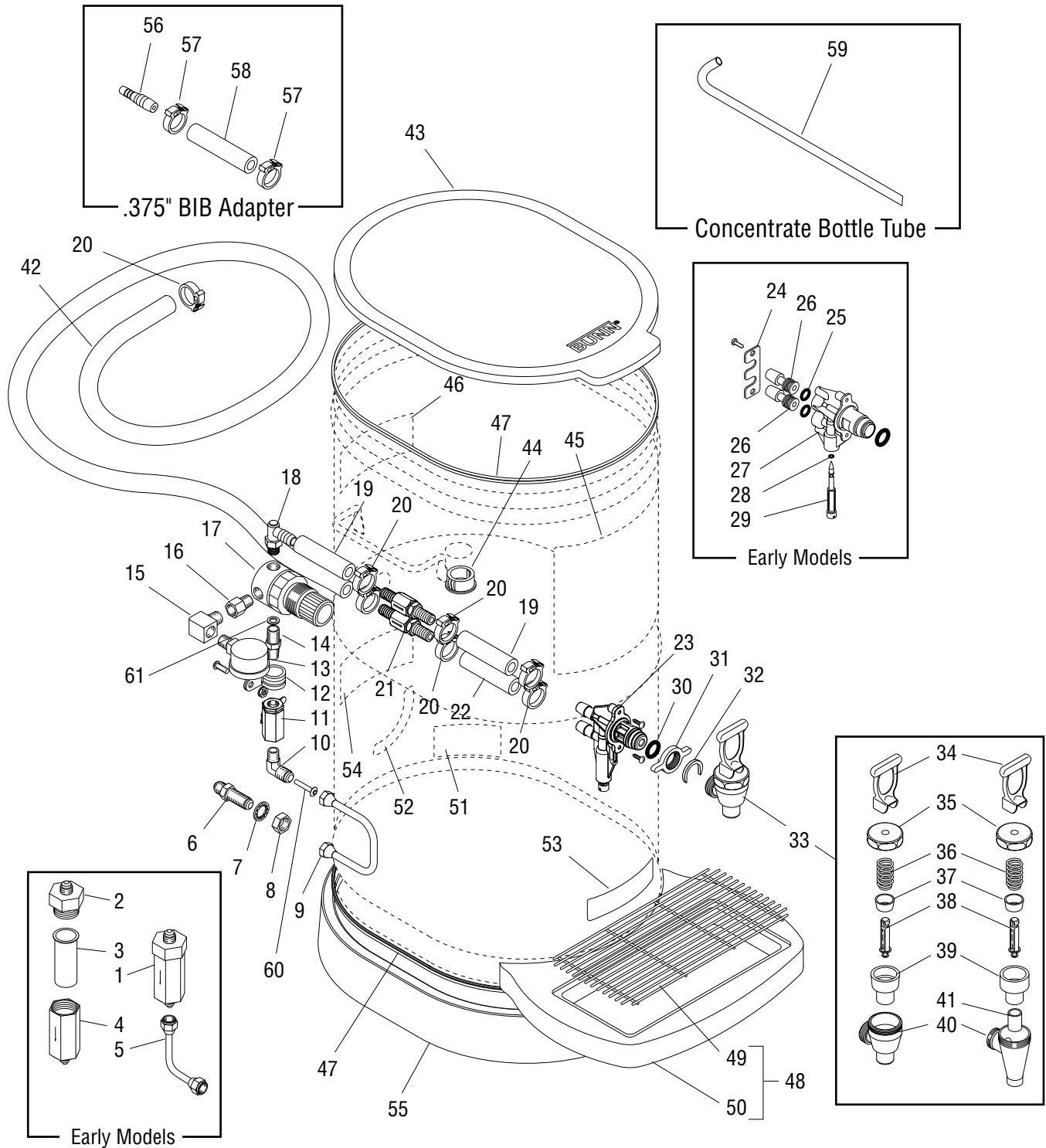



## REPLACEMENT PARTS (TCD-1)

ITEM	PART NO.	QTY.	DESCRIPTION
27	-----	1	Venturi Mixer (Order item 23)
28	37691.0000	1	O-ring
29	37486.0000	1	Adjustment Screw, Venturi
30	32852.0000	1	O-ring
31	03093.0001	1	Wing Nut, Faucet
	01268.0000	1	Chrome Nut, Faucet Union (Optional)
32	01221.0001	1	C-Ring, Faucet Shank
33	03260.0004	1	Faucet Assy, Black Plastic Body (Includes items 34 thru 40)(Refer to page 18 for important ordering information)(See item 67)
	03260.0005	1	Faucet Assy, Chrome Body (Includes items 34 thru 41)(See item 67)
34	29163.0007	1	Handle, Faucet
	29163.0012	1	Handle, Faucet (SWEET)
	29163.0013	1	Handle, Faucet (UNSWEET) } Optional
35	29165.0002	1	Bonnet, Faucet
36	00601.0001	1	Spring Faucet
37	37715.0000	1	Collar, Spring (Refer to item 66)
38	29164.0000	1	Stem, Faucet
39	00600.0001	1	Seat Cup, Faucet (Refer to item 66)
40	35758.0002*	1	Faucet Body, Black Plastic (Order item 33)
	35206.0000*	1	Faucet Body, Chrome (Order item 33)
41	38473.0000	1	Insert
42	-----	1	Tube, Silicone .25" ID x 36.0" (For first replacement, order item 59)
	20976.0078*	1	Tube, Silicone .375" ID x 60.0" (Order item 64)
43	34093.0000	1	Lid, Reservoir
44	01592.0000	2	Bushing, 1.0" Dia
45	03043.0006	1	Decal, Iced Tea (See page 18 for proper placement)
46	38130.0000	1	Decal, Faucet Under Pressure
47	38278.0002*	2	Edging 36.0" (Order item 69)
48	38029.1000	1	Drip Tray Assy (Includes items 49 & 50)
49	26801.0000	1	Drip Tray Cover
50	03207.0004	1	Drip Tray
51	38465.0000	1	Decal, Pressure Regulator
52	38466.0000	1	Decal, Shut-off

(continued)

\* Indicates the part number listed is for reference only. See DESCRIPTION for possible service replacement.

(continued)

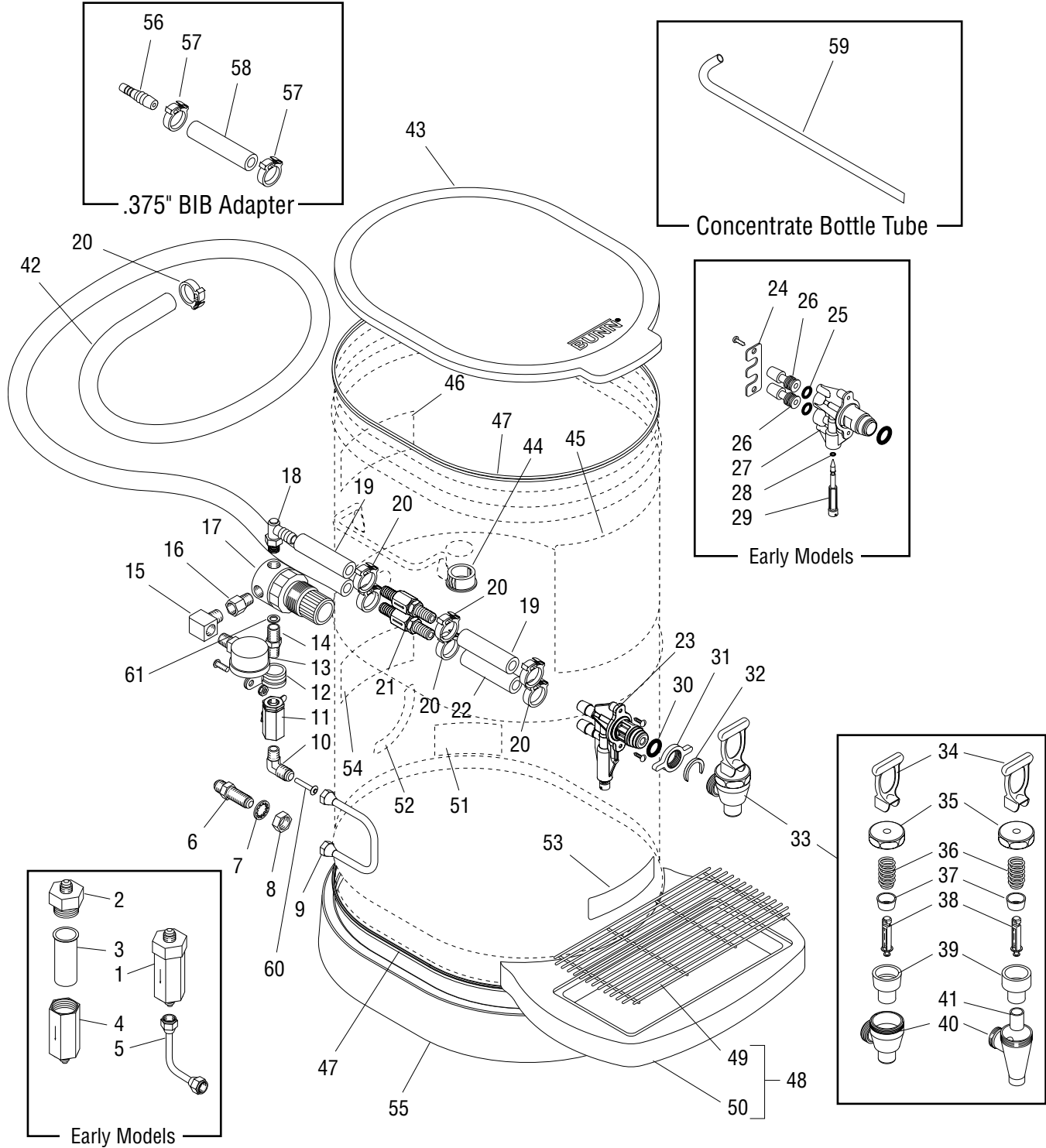

## REPLACEMENT PARTS (TCD-1)

ITEM	PART NO.	QTY.	DESCRIPTION	
53	00651.0000	1	Decal, BUNN	
54	00656.0001	1	Decal, Plumbing Code	
55	38839.0000	1	Stand (Optional)	
56	26443.0000	1	Reducer, Barb .375" x .25"	} For use with .375" BIB adapter
	34644.0000	1	Connector, Barb .375" x .375"	
57	12422.0001	2	Clamp, Hose .59"/.66"	
58	37720.0000*	1	Tube, Silicone .375" ID x 3.0" (Order item 64)	} Optional
59	37744.0000	1	Tube, Concentrate Bottle .25"	
	37744.0001	1	Tube, Concentrate Bottle .375"	
60	39216.0000	1	Screen Filter (Late Models)	
61	27574.0000	1	Sealing Washer	

### The Following Items Are Not Illustrated

62	00674.0000	1	Brush, Tube .75"
	00674.1000	1	Brush, Tube .75" (Includes 6 Brushes)
63	M2531.0000	1	Lube&Sealant Compound
64	37721.1000	-	Tube, Silicone .25" ID x 12.0"
	37721.1001	-	Tube, Silicone .25" ID x 36.0"
	37721.1002	-	Tube, Silicone .25" ID x 120.0"
65	20976.1000	-	Tube, Silicone .375" ID x 12.0"
	20976.1001	-	Tube, Silicone .375" ID x 36.0"
	20976.1002	-	Tube, Silicone .375" ID x 120.0"
66	37747.1000	-	Parts Bag (Includes items 1,5,20,33,45 & 59)(with 3.0" BIB hose)
	37747.1001	-	Parts Bag (Includes items 1,5,20,33,48,58 & 59)(with 36.0" BIB hose)
67	38471.0000	-	Kit, Faucet Seat Cup (Includes items 37 & 39)
68	28707.0004	-	Kit, Faucet Repair (Includes items 34 & 36-39)
69	38278.1002	-	Edging 36.0" (Use as required)
70	39169.0000	-	Tube Replacement Kit (Includes items 20,21,22,26 & 42)

\* Indicates the part number listed is for reference only. See DESCRIPTION for possible service replacement.

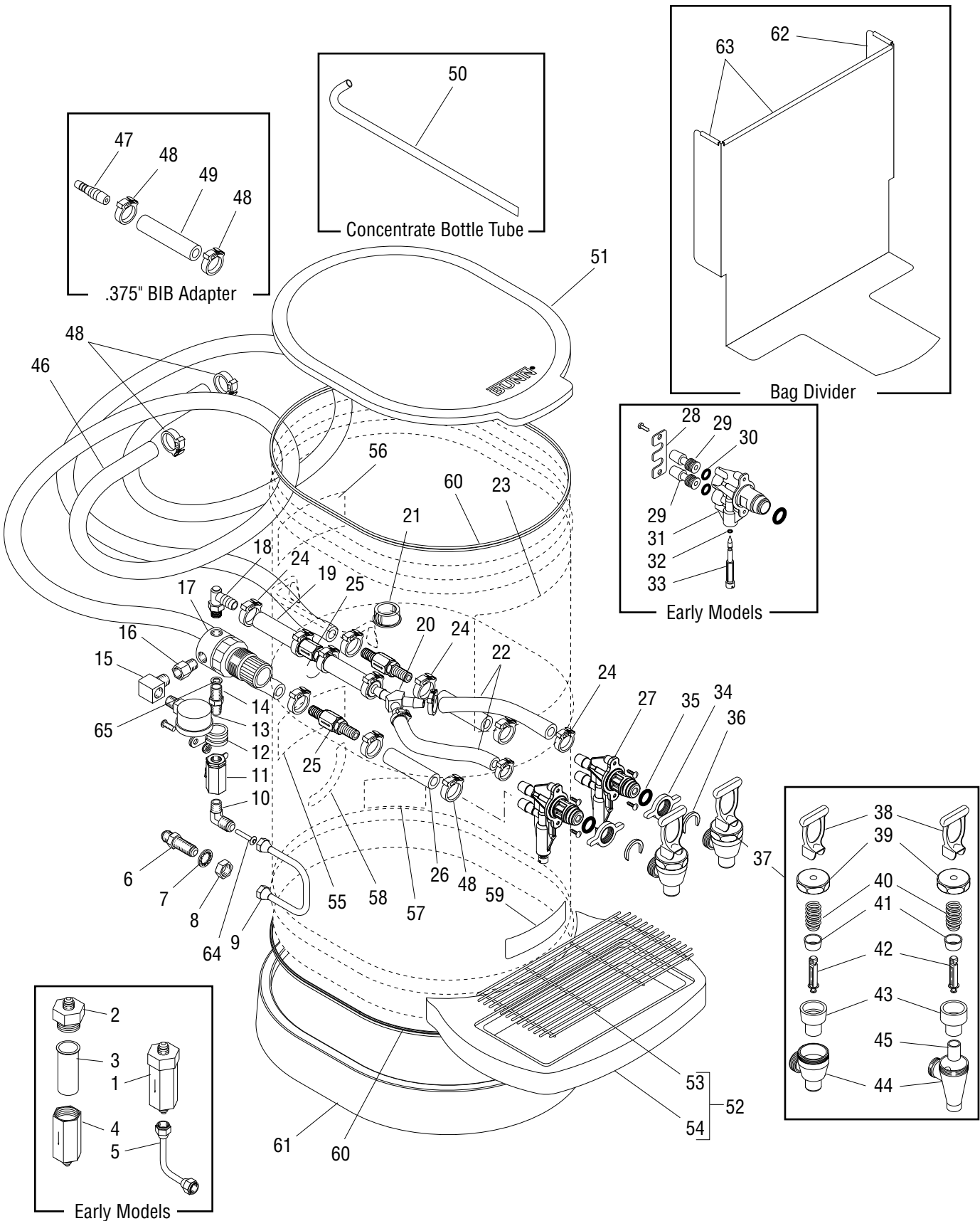

## REPLACEMENT PARTS (TCD-2)

ITEM	PART NO.	QTY.	DESCRIPTION
<b>NOTE: Effective August 2006, the Venturi and product delivery tubing was changed from .25"ID to .375"ID to improve flow rate. If for first replacement, order Tube Replacement Kit P/N 39169.0000 (2 kits required for TCD-2)</b>			
1	23820.1000	1	Water Strainer Assy (Includes items 2 thru 4)
2	22249.0000	1	Cap, Water Strainer
3	23721.0000	1	Screen
4	23819.0000*	1	Housing (Order item 1)
5	00310.0006	1	Tube Assy, Strainer to Bulkhead
6	00459.0001	1	Fitting, Bulkhead
7	01532.0000	1	Lockwasher, Internal Tooth .438"
8	00463.0000	1	Nut, .438" - 20
9	37689.0000	1	Tube Assy, Bulkhead to Shut-off
10	32891.0001	1	Elbow, Male .25" FLR x .25" MPT
11	33113.0000	1	Valve, Ball .25" FPT x .25" FPT
12	32360.0001	1	Clamp, .613" ID
	01315.0000	1	Screw, Truss Head #8-32 x .375"
	00991.0000	1	Nut #8-32
13	37898.0000	1	Gauge, Pressure
14	37742.0001	1	Nipple, .25" MPT
15	00432.0001	1	Elbow, .125" NPT Male/Female
16	00430.0001	1	Adapter, .125" NPT Male/Female
17	21993.0005	1	Regulator, Water, Low Flow (TCD models except 37750.0037 & 37750.0038)
	21993.0006	1	Regulator, Water, Low Flow (TCD models 37750.0037 & 37750.0038 only)
18	37460.0000	1	Fitting, Barb Elbow .25" NPT
19	37720.0004*	2	Tube, Silicone .375" ID x 1.75" (Order item 68)
20	38023.0000	1	Y-Fitting, Barb .25" Hose
21	01592.0000	4	Bushing, 1.0" Dia
22	37720.0001*	2	Tube, Silicone .375" ID x 5.25" (Order item 68)
23	03043.0006	1	Decal, Iced Tea (See page 18 for proper placement)
24	12422.0001	16	Clamp, Hose .59"/.66"
25	40071.0001	3	Valve, Check .375"
26	-----	2	Tube, Silicone .25" ID x 3.5" (If for first replacement, order item 73)
	37720.0004*	2	Tube, Silicone .375" ID x 1.75" (Order item 68)
27	37736.1000	2	Venturi Assy (.25" product tubing)(Each includes items 28,30-33 & 36)
	37736.1001	2	Venturi Assy (.375" product tubing)(Each includes items 28 thru 33 & 36)
	37736.1002	2	Venturi Assy w/Barbs (.375" tubing)(Includes item 32, 33 & 35)(Late Models)
	01360.0002	4	Screw, Plascrew #6 x .375"
28	43111.0000	1	Plate, Fitting Retainer
	38044.0000	2	Screw, Plastite #6 x .375"

Early Models

(continued)

\* Indicates the part number listed is for reference only. See DESCRIPTION for possible service replacement.

(continued)

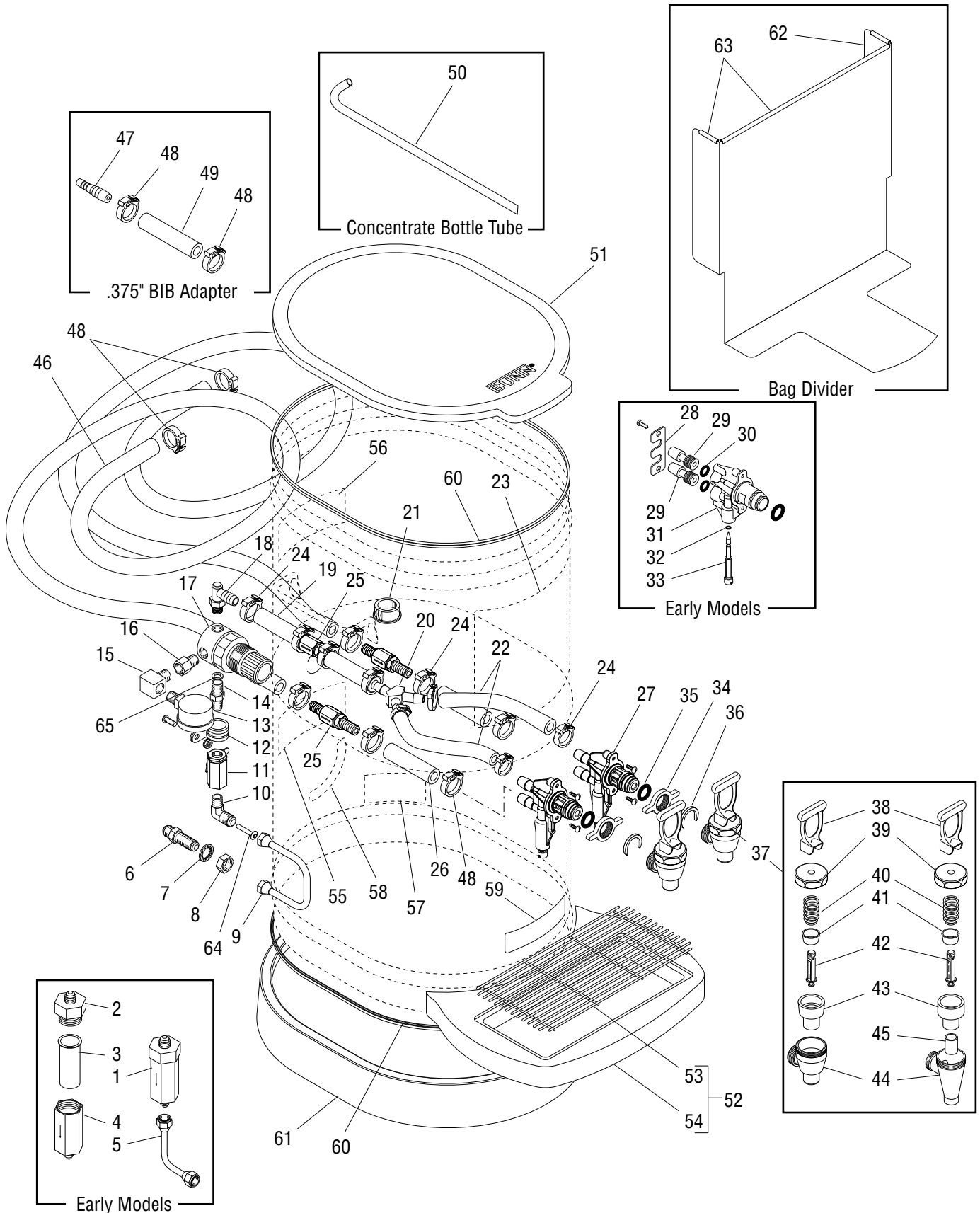

## REPLACEMENT PARTS (TCD-2)

ITEM	PART NO.	QTY.	DESCRIPTION
29	32631.1002	2	Fitting, Barb .375"
30	32849.0001	2	O-ring
31	-----	1	Venturi Mixer (Order item 27)
32	37691.0000	1	O-ring
33	37486.0000	1	Adjustment Screw, Venturi
34	03093.0001	2	Wing Nut, Faucet
	01268.0000	2	Chrome Nut, Faucet Union (Optional)
35	32852.0000	2	O-ring
36	01221.0001	2	C-Ring, Faucet Shank
37	03260.0004	2	Faucet Assy, Black Plastic Body (Includes items 38 thru 44)(Refer to page 18 for important ordering information)(See item 71)
	03260.0005	2	Faucet Assy, Chrome Body (Includes items 38 thru 45)(See item 71)
38	29163.0007	1	Handle, Faucet
	29163.0012	1	Handle, Faucet (SWEET)
	29163.0013	1	Handle, Faucet (UNSWEET)
			} Optional
39	29165.0002	1	Bonnet, Faucet
40	00601.0001	1	Spring Faucet
41	37715.0000	1	Collar, Spring (Refer to item 70)
42	29164.0000	1	Stem, Faucet
43	00600.0001	1	Seat Cup, Faucet (Refer to item 70)
44	35758.0002*	1	Faucet Body, Black Plastic (Order item 37)
	35206.0000*	1	Faucet Body, Chrome (Order item 37)
45	38473.0000	1	Insert
46	-----	2	Tube, Silicone .25" ID x 36.0" (If for first replacement, order item 73)
	20976.0078*	2	Tube, Silicone .375" ID x 60.0" (Order item 68)
47	26443.0000	2	Reducer, Barb .375" x .25"
	34644.0000	2	Connector, Barb .375" x .375"
48	12422.0001	12	Clamp, Hose .59"/.66"
49	37720.0000*	2	Tube, Silicone .375" ID x 3.0" (Order item 68)
			} For use with .375" BIB adapter
50	37744.0000	2	Tube, Concentrate Bottle .25"
	37744.0001	2	Tube, Concentrate Bottle .375"
			} Optional
51	34093.0000	1	Lid, Reservoir
52	38029.1000	1	Drip Tray Assy (Includes items 53 & 54)
53	26801.0000	1	Drip Tray Cover
54	03207.0004	1	Drip Tray
55	00656.0001	1	Decal, Plumbing Code
56	38130.0000	1	Decal, Faucet Under Pressure

(continued)

\* Indicates the part number listed is for reference only. See DESCRIPTION for possible service replacement.

(continued)

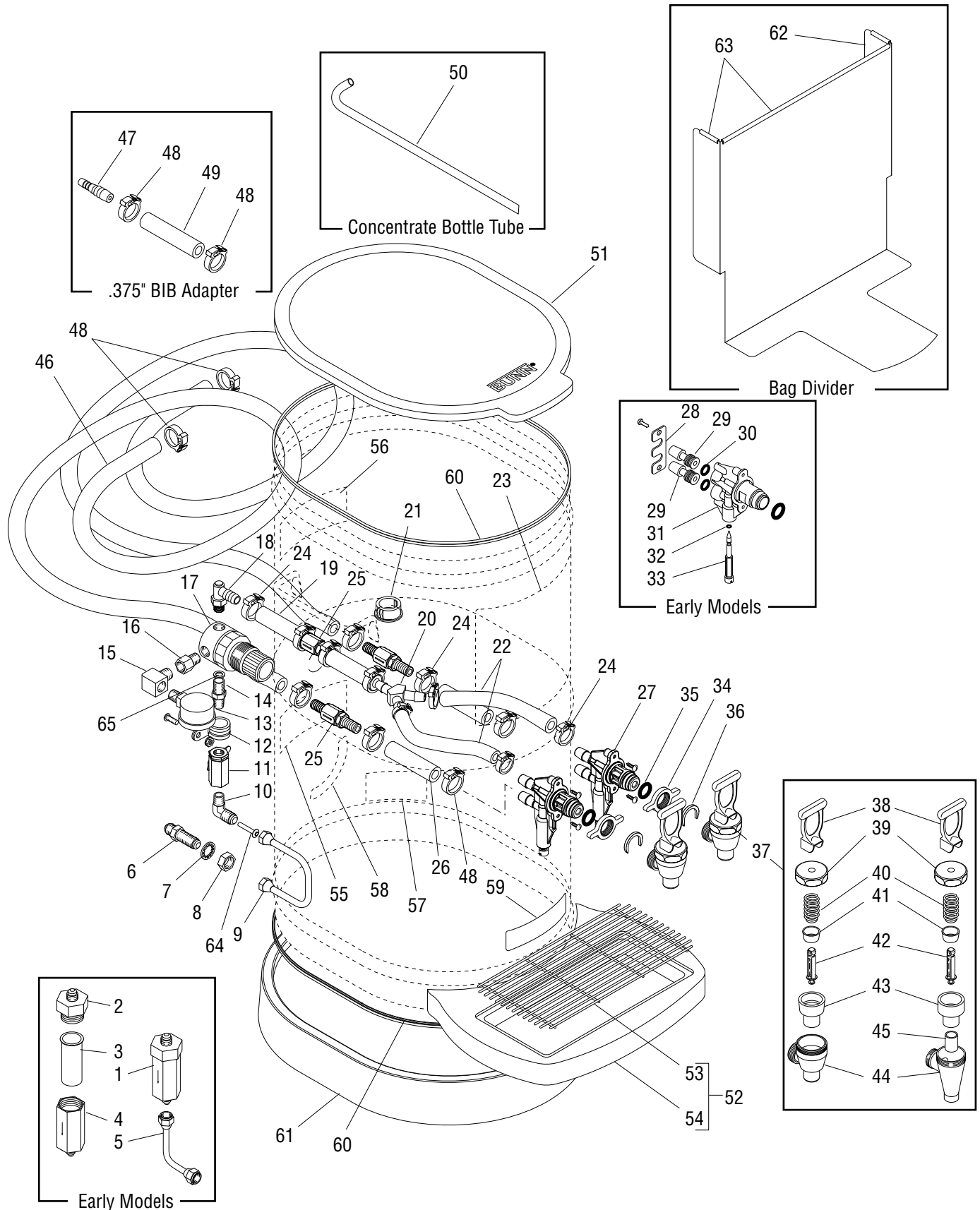



## REPLACEMENT PARTS (TCD-2)

ITEM	PART NO.	QTY.	DESCRIPTION
57	38465.0000	1	Decal, Pressure Regulator
58	38466.0000	1	Decal, Shut-off
59	00651.0000	1	Decal, BUNN
60	38278.0002*	2	Edging 36.0" (Order item 73)
61	38839.0000	1	Stand
62	38745.1000	1	Bag Divider (Includes Item 63)
63	38278.0001*	1	Edging 9.5" (Order item 72)
	38278.0003*	2	Edging 1.0" (Order item 72)
64	39216.0000	1	Screen Filter (Late Models)
65	27574.0000	1	Sealing Washer
<b>The Following Items Are Not Illustrated</b>			
66	00674.0000	1	Brush, Tube .75"
	00674.1000	1	Brush, Tube .75" (Includes 6 Brushes)
67	M2531.0000	1	Lube&Sealant Compound
68	37721.1000	-	Tube, Silicone .25" ID x 12.0"
	37721.1001	-	Tube, Silicone .25" ID x 36.0"
	37721.1002	-	Tube, Silicone .25" ID x 120.0"
69	20976.1000	-	Tube, Silicone .375" ID x 12.0"
	20976.1001	-	Tube, Silicone .375" ID x 36.0"
	20976.1002	-	Tube, Silicone .375" ID x 120.0"
70	37747.1002	-	Parts Bag (Includes items 1,5,23,37,48 & 50)(with 3.0" BIB hose)
	37747.1003	-	Parts Bag (Includes items 1,5,37,47,48,49,50 & 52)(with 36.0" BIB hose)
71	38471.0000	-	Kit, Faucet Seat Cup (Includes items 41 & 43)
72	28707.0004	-	Kit, Faucet Repair (Includes items 38 & 40-43)
73	38278.1002	-	Edging 36.0" (Use as required)
74	39169.0000	-	Tube Replacement Kit (Includes items 25,29,46,48-50)(Two Kits required for TCD-2)

\* Indicates the part number listed is for reference only. See DESCRIPTION for possible service replacement.

## ICED TEA DECAL PLACEMENT

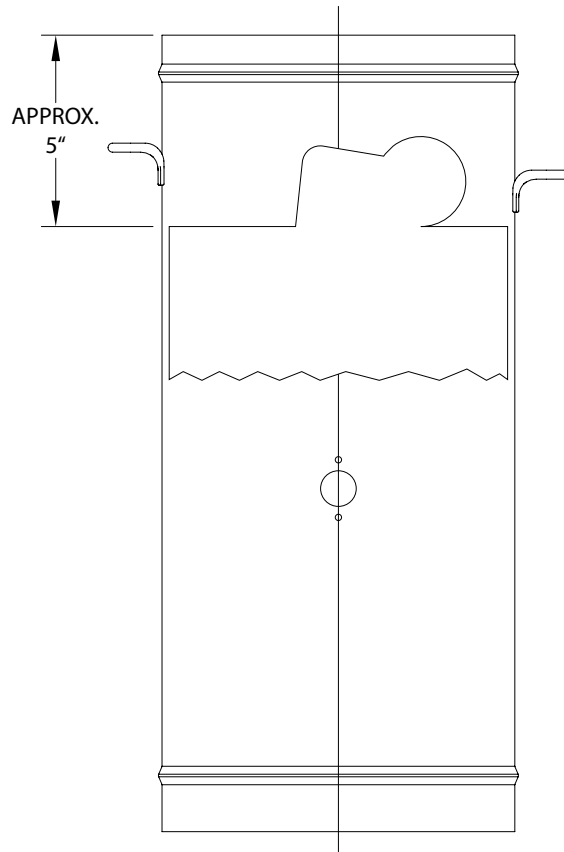

## PLASTIC BODY FAUCET COMPARISON

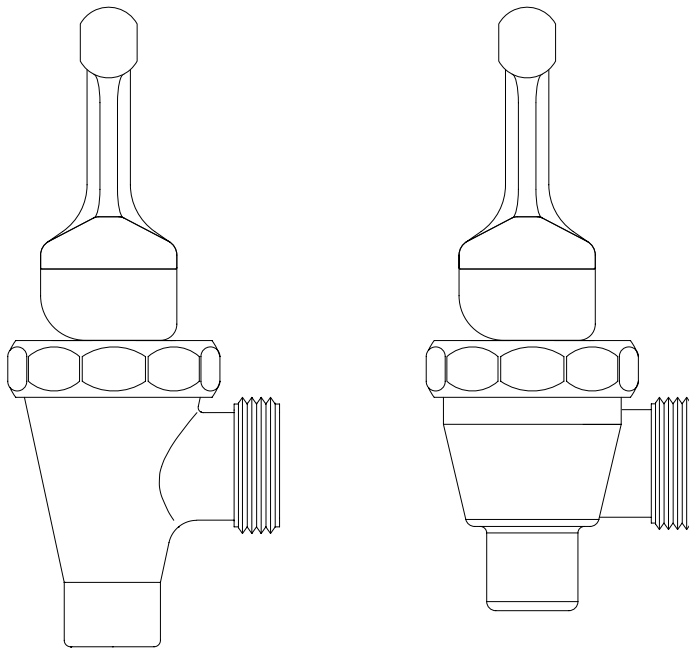

If you have a plastic body faucet of this design, you must order a complete new plastic faucet.

New Plastic Faucet Design