

# **BUNN**<sup>®</sup>

## **3.0 Gallon TITAN TF SERVER**

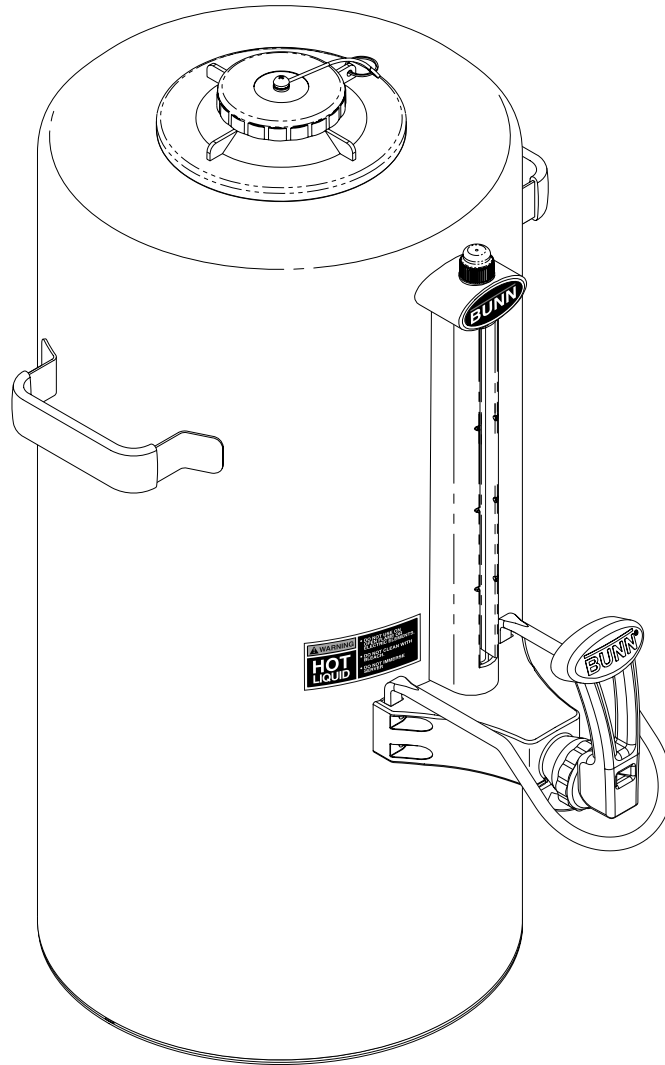

## **USE & CARE INFORMATION**

**CAUTION:** CLEAN AND SANITIZE YOUR SERVER BEFORE USING. SEE NOTE 1 of DAILY CLEANING.

### **BUNN-O-MATIC CORPORATION**

POST OFFICE BOX 3227  
SPRINGFIELD, ILLINOIS 62708-3227  
PHONE: (217) 529-6601 FAX: (217) 529-6644



## INTRODUCTION

This server is intended for use with a BUNN® TITAN DUAL, or TITAN SINGLE coffee brewer only. When proper precautions are followed, 1.5 to 3.0 gallons of coffee may be brewed directly into the server and then transported to a remote serving location. The server must be placed on a sturdy counter or shelf.

## USER NOTICES

The notices on this server should be kept in good condition. Replace unreadable or damaged labels.

#26186.0000



## DAILY CLEANING

### **CAUTION: CLEAN AND SANITIZE YOUR SERVER DAILY**

**NOTE:** Bunn-O-Matic recommends the three step method for cleaning and sanitizing the server. The 3 step method consists of hot soapy water using an mild, non-citrus detergent, a fresh water rinse and an aqueous sanitizing solution using a non-chlorine sanitizer. Do not submerge the server. Failure to follow the recommended cleaning procedures can cause corrosion to the stainless steel surface and damage the vacuum seal. **USE OF ANY CHLORINATED PRODUCT VOIDS THE FACTORY WARRANTY.**

1. Run a complete brew cycle *of just hot water* into the server and let it set for a minute. Empty the server completely by opening the faucet.
2. Remove the lid, fill server with cleaning solution and thoroughly clean the inside of server.
3. Rinse server thoroughly using fresh water rinse.
4. Fully fill server with sanitizing solution for 5 minutes then drain through fully open faucet.
5. Remove the faucet handle/stem assembly by unscrewing the faucet nut just behind the faucet handle.
6. Use enclosed cleaning brush to thoroughly clean the faucet spout and connector.
7. Remove the cap, sight gauge tube and washers.
8. Use enclosed cleaning brush to thoroughly clean the fill tube of the lid assembly and sight gauge tube.
9. Disassemble the faucet/stem assembly. Thoroughly wash all faucet parts and lid in a mild detergent and water solution. Rinse the parts in hot water. Sanitize the parts for five minutes, then air dry completely.
10. Reassemble the faucet/stem assembly and attach it to the faucet. When reassembling - **CAUTION: DO NOT over-tighten faucet wing nut or faucet bonnet - HAND TIGHTEN ONLY.**
11. Install the sight gauge tube and washers in the shroud and secure with the shroud cap.
12. Clean the entire outside surface of the server using a clean **SOFT, Non-abrasive** cloth dampened with any mild, non-citrus, non-abrasive, liquid detergent.
13. Thoroughly rinse the entire server after cleaning.

# SERVER

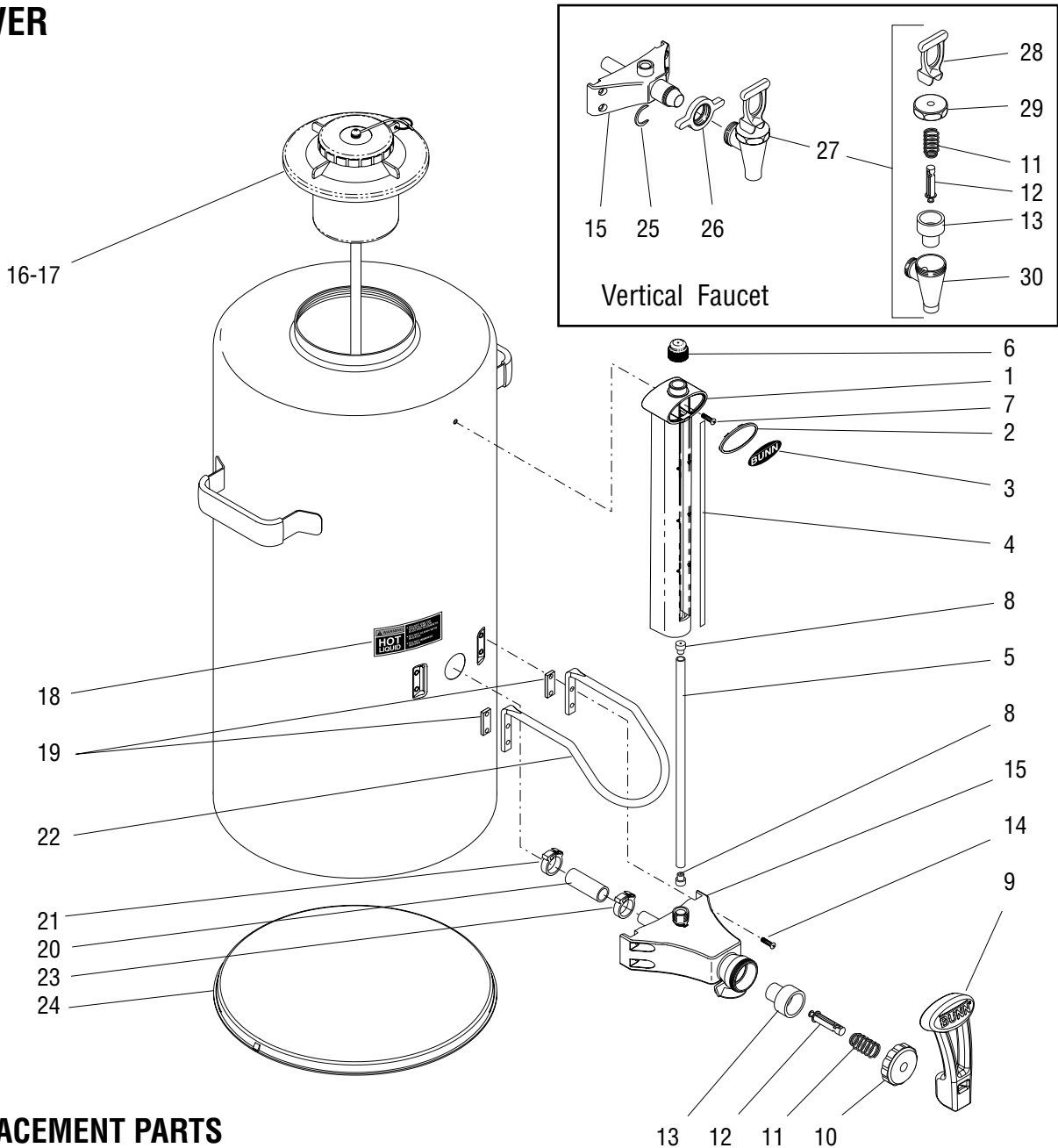

P3896

## REPLACEMENT PARTS

1.	39542.1000	Shroud, Sight Gauge (Includes Item 4)	18.	26186.0000	Decal, Warning Hot Liquid
2.	35010.0000	Plate, Decal Mounting	19.	40097.0001	Spacer
3.	35009.0000	Decal, Bunn	20.	32591.1000	Tube, Silicone .50" I.D. x 2.0"(Cut to length)
	35009.0001	Decal, Plain Black	21.	12422.0001	Clamp, Tube .59"/.66" I.D.
4.	35004.0002	Backing, Sight Gauge 3.0 Gal.	22.	39543.0001	Guard, Faucet
5.	35005.0003	Sight Gauge Tube 3.0 Gal.	23.	12422.0012	Clamp, Tube .81"/.97" I.D.
6.	39083.0000	Cap, Shroud	24.	40271.1100	Cover, Bottom
7.	02367.0000	Screw, Truss Head #6-32 x .62"		45279.0000	Screw, Pan Head #8-32 x .25"
8.	39143.0001	Washer, Sight Gauge Tube	25.	01221.0000	C-Ring, Faucet Shank
9.	39081.0000	Handle, Faucet, Bunn (Horizontal Faucet)	26.	03093.0002	Wing Nut, Faucet
10.	35003.0000	Nut, Faucet Spout (Horizontal Faucet)	27.	26685.0000	Faucet Assy, Bunn Handle
11.	00601.0000*	Faucet Spring		26685.0003	Faucet Assy, Plain Black Handle
12.	29164.0000*	Faucet Stem	28.	26684.0000*	Faucet Handle, Bunn
13.	00600.0000*	Faucet Seat Cup		07096.0007*	Faucet Handle, Plain black
14.	35074.0000	Screw, Hex Hd Black M4 x .7x25	29.	29165.0001*	Faucet Bonnet
15.	40132.0000	Spout, Faucet (Horizontal Faucet)	30.	-----*	Faucet Body (Not available. Order item 27)
	41159.0001	Shank, Faucet (Vertical Faucet)	31.	35301.0000	Brush, Cleaning (Not Illustrated)
16.	39487.1000	Lid Assembly 3.0 Gal. (Includes item 17)			
17.	40106.0000	Cap Assembly			

\* Component of item 27

## BUNN-O-MATIC COMMERCIAL PRODUCT WARRANTY

Bunn-O-Matic Corp. ("BUNN") warrants equipment manufactured by it as follows:

- 1) Airpots, thermal carafes, decanters, GPR servers, iced tea/coffee dispensers, MCR/MCP/MCA single cup brewers, thermal servers and ThermoFresh® servers (mechanical and digital) 1 year parts and 1 year labor.
- 2) All other equipment - 2 years parts and 1 year labor plus added warranties as specified below:
  - a) Electronic circuit and/or control boards - parts and labor for 3 years.
  - b) Compressors on refrigeration equipment - 5 years parts and 1 year labor.
  - c) Grinding burrs on coffee grinding equipment to grind coffee to meet original factory screen sieve analysis - parts and labor for 4 years or 40,000 pounds of coffee, whichever comes first.

These warranty periods run from the date of installation BUNN warrants that the equipment manufactured by it will be commercially free of defects in material and workmanship existing at the time of manufacture and appearing within the applicable warranty period. This warranty does not apply to any equipment, component or part that was not manufactured by BUNN or that, in BUNN's judgment, has been affected by misuse, neglect, alteration, improper installation or operation, improper maintenance or repair, non periodic cleaning and descaling, equipment failures related to poor water quality, damage or casualty. In addition, the warranty does not apply to replacement of items subject to normal use including but not limited to user replaceable parts such as seals and gaskets. This warranty is conditioned on the Buyer 1) giving BUNN prompt notice of any claim to be made under this warranty by telephone at (217) 529-6601 or by writing to Post Office Box 3227, Springfield, Illinois 62708-3227; 2) if requested by BUNN, shipping the defective equipment prepaid to an authorized BUNN service location; and 3) receiving prior authorization from BUNN that the defective equipment is under warranty.

**THE FOREGOING WARRANTY IS EXCLUSIVE AND IS IN LIEU OF ANY OTHER WARRANTY, WRITTEN OR ORAL, EXPRESS OR IMPLIED, INCLUDING, BUT NOT LIMITED TO, ANY IMPLIED WARRANTY OF EITHER MERCHANTABILITY OR FITNESS FOR A PARTICULAR PURPOSE.** The agents, dealers or employees of BUNN are not authorized to make modifications to this warranty or to make additional warranties that are binding on BUNN. Accordingly, statements by such individuals, whether oral or written, do not constitute warranties and should not be relied upon.

If BUNN determines in its sole discretion that the equipment does not conform to the warranty, BUNN, at its exclusive option while the equipment is under warranty, shall either 1) provide at no charge replacement parts and/or labor (during the applicable parts and labor warranty periods specified above) to repair the defective components, provided that this repair is done by a BUNN Authorized Service Representative; or 2) shall replace the equipment or refund the purchase price for the equipment.

**THE BUYER'S REMEDY AGAINST BUNN FOR THE BREACH OF ANY OBLIGATION ARISING OUT OF THE SALE OF THIS EQUIPMENT, WHETHER DERIVED FROM WARRANTY OR OTHERWISE, SHALL BE LIMITED, AT BUNN'S SOLE OPTION AS SPECIFIED HEREIN, TO REPAIR, REPLACEMENT OR REFUND.**

In no event shall BUNN be liable for any other damage or loss, including, but not limited to, lost profits, lost sales, loss of use of equipment, claims of Buyer's customers, cost of capital, cost of down time, cost of substitute equipment, facilities or services, or any other special, incidental or consequential damages.

392, A Partner You Can Count On, Air Infusion, AutoPOD, AXIOM, BrewLOGIC, BrewMETER, Brew Better Not Bitter, BrewWISE, BrewWIZARD, BUNN Espresso, BUNN Family Gourmet, BUNN Gourmet, BUNN Pour-O-Matic, BUNN, BUNN with the stylized red line, BUNNlink, Bunn-O-Matic, Bunn-O-Matic, BUNNserve, BUNNSERVE with the stylized wrench design, Cool Froth, DBC, Dr. Brew stylized Dr. design, Dual, Easy Pour, EasyClear, EasyGard, FlavorGard, Gourmet Ice, Gourmet Juice, High Intensity, iMIX, Infusion Series, Intellisteam, My Café, Phase Brew, PowerLogic, Quality Beverage Equipment Worldwide, Respect Earth, Respect Earth with the stylized leaf and coffee cherry design, Safety-Fresh, savemycoffee.com, Scale-Pro, Silver Series, Single, Smart Funnel, Smart Hopper, SmartWAVE, Soft Heat, SplashGard, The Mark of Quality in Beverage Equipment Worldwide, ThermoFresh, Titan, trifacta, TRIFECTA (stylized logo), Velocity Brew, Air Brew, Beverage Bar Creator, Beverage Profit Calculator, Brew better, not bitter., Build-A-Drink, BUNNSource, Coffee At Its Best, Cyclonic Heating System, Daypart, Digital Brewer Control, Element, Milk Texturing Fusion, Nothing Brews Like a BUNN, Picture Prompted Cleaning, Pouring Profits, Signature Series, Sure Tamp, Tea At Its Best, The Horizontal Red Line, Ultra are either trademarks or registered trademarks of Bunn-O-Matic Corporation. The commercial trifacta® brewer housing configuration is a trademark of Bunn-O-Matic Corporation.