

# **BUNN**®

## ***TITAN DUAL™*** ***TITAN SINGLE™***

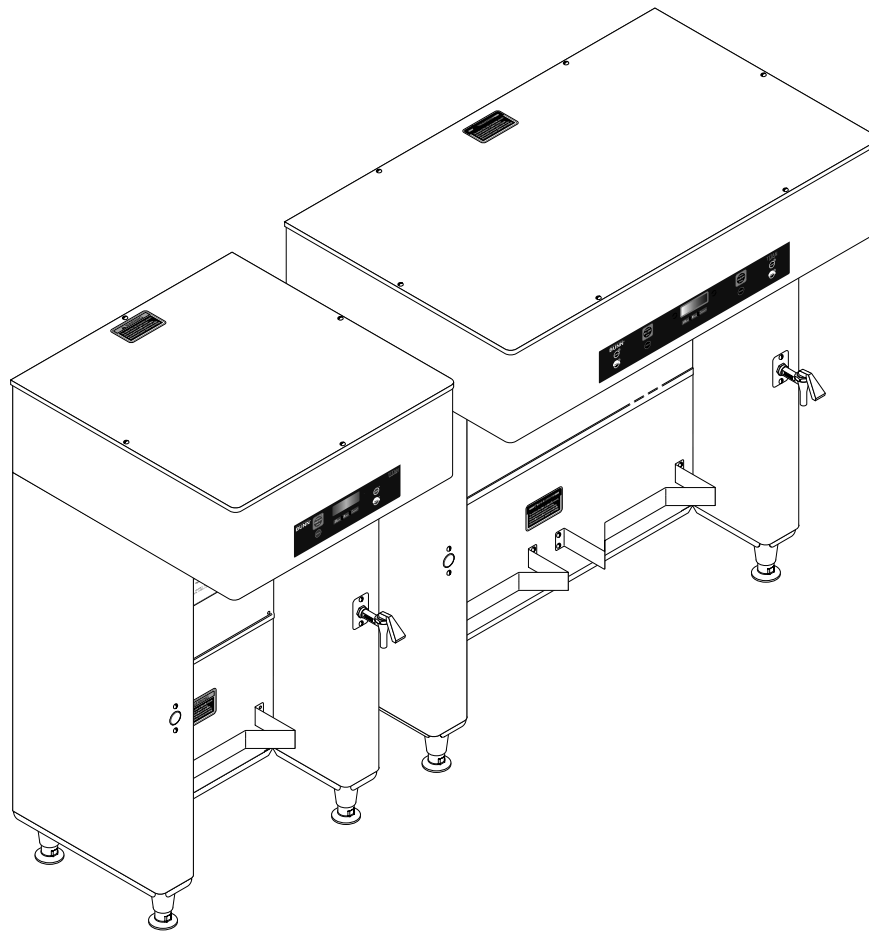

## **SERVICE & REPAIR MANUAL**

**BUNN-O-MATIC CORPORATION**

POST OFFICE BOX 3227

SPRINGFIELD, ILLINOIS 62708-3227

PHONE: (217) 529-6601 FAX: (217) 529-6644

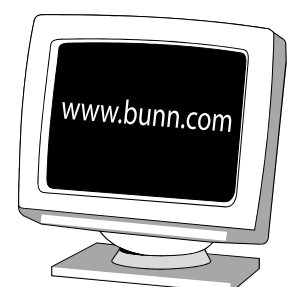

## **BUNN-O-MATIC COMMERCIAL PRODUCT WARRANTY**

Bunn-O-Matic Corp. ("BUNN") warrants equipment manufactured by it as follows:

- 1) Airpots, thermal carafes, decanters, GPR servers, iced tea/coffee dispensers, MCP/MCA pod brewers thermal servers and Thermofresh servers (mechanical and digital)- 1 year parts and 1 year labor.
- 2) All other equipment - 2 years parts and 1 year labor plus added warranties as specified below:
  - a) Electronic circuit and/or control boards - parts and labor for 3 years.
  - b) Compressors on refrigeration equipment - 5 years parts and 1 year labor.
  - c) Grinding burrs on coffee grinding equipment to grind coffee to meet original factory screen sieve analysis - parts and labor for 4 years or 40,000 pounds of coffee, whichever comes first.

These warranty periods run from the date of installation BUNN warrants that the equipment manufactured by it will be commercially free of defects in material and workmanship existing at the time of manufacture and appearing within the applicable warranty period. This warranty does not apply to any equipment, component or part that was not manufactured by BUNN or that, in BUNN's judgment, has been affected by misuse, neglect, alteration, improper installation or operation, improper maintenance or repair, non periodic cleaning and descaling, equipment failures related to poor water quality, damage or casualty. In addition, the warranty does not apply to replacement of items subject to normal use including but not limited to user replaceable parts such as seals and gaskets. This warranty is conditioned on the Buyer 1) giving BUNN prompt notice of any claim to be made under this warranty by telephone at (217) 529-6601 or by writing to Post Office Box 3227, Springfield, Illinois 62708-3227; 2) if requested by BUNN, shipping the defective equipment prepaid to an authorized BUNN service location; and 3) receiving prior authorization from BUNN that the defective equipment is under warranty.

**THE FOREGOING WARRANTY IS EXCLUSIVE AND IS IN LIEU OF ANY OTHER WARRANTY, WRITTEN OR ORAL, EXPRESS OR IMPLIED, INCLUDING, BUT NOT LIMITED TO, ANY IMPLIED WARRANTY OF EITHER MERCHANTABILITY OR FITNESS FOR A PARTICULAR PURPOSE.** The agents, dealers or employees of BUNN are not authorized to make modifications to this warranty or to make additional warranties that are binding on BUNN. Accordingly, statements by such individuals, whether oral or written, do not constitute warranties and should not be relied upon.

If BUNN determines in its sole discretion that the equipment does not conform to the warranty, BUNN, at its exclusive option while the equipment is under warranty, shall either 1) provide at no charge replacement parts and/or labor (during the applicable parts and labor warranty periods specified above) to repair the defective components, provided that this repair is done by a BUNN Authorized Service Representative; or 2) shall replace the equipment or refund the purchase price for the equipment.

**THE BUYER'S REMEDY AGAINST BUNN FOR THE BREACH OF ANY OBLIGATION ARISING OUT OF THE SALE OF THIS EQUIPMENT, WHETHER DERIVED FROM WARRANTY OR OTHERWISE, SHALL BE LIMITED, AT BUNN'S SOLE OPTION AS SPECIFIED HEREIN, TO REPAIR, REPLACEMENT OR REFUND.**

In no event shall BUNN be liable for any other damage or loss, including, but not limited to, lost profits, lost sales, loss of use of equipment, claims of Buyer's customers, cost of capital, cost of down time, cost of substitute equipment, facilities or services, or any other special, incidental or consequential damages.

392, AutoPOD, AXIOM, BrewLOGIC, BrewMETER, Brew Better Not Bitter, BrewWISE, BrewWIZARD, BUNN Espresso, BUNN Family Gourmet, BUNN Gourmet, BUNN Pour-O-Matic, BUNN, BUNN with the stylized red line, BUNNlink, Bunn-OMatic, Bunn-O-Matic, BUNNserve, BUNNSERVE with the stylized wrench design, Cool Froth, DBC, Dr. Brew stylized Dr. design, Dual, Easy Pour, EasyClear, EasyGard, FlavorGard, Gourmet Ice, Gourmet Juice, High Intensity, iMIX, Infusion Series, Intellisteam, My Café, Phase Brew, PowerLogic, Quality Beverage Equipment Worldwide, Respect Earth, Respect Earth with the stylized leaf and coffee cherry design, Safety-Fresh, savemycoffee.com, Scale-Pro, Silver Series, Single, Smart Funnel, Smart Hopper, SmartWAVE, Soft Heat, SplashGard, The Mark of Quality in Beverage Equipment Worldwide, ThermoFresh, Titan, trifecta, Velocity Brew, A Partner You Can Count On, Air Brew, Air Infusion, Beverage Bar Creator, Beverage Profit Calculator, Brew better, not bitter., BUNNSource, Coffee At Its Best, Cyclonic Heating System, Daypart, Digital Brewer Control, Nothing Brews Like a BUNN, Pouring Profits, Signature Series, Tea At Its Best, The Horizontal Red Line, Ultra are either trademarks or registered trademarks of Bunn-O-Matic Corporation.

## INTRODUCTION

This equipment will brew coffee into an awaiting server or airpot. The brewer may have an auxillary hot water faucet. It is only for indoor use on a sturdy and level counter or shelf. Please install in an area where there are no water jet devices.

This brewer can be programmed to adjust different functions of the brewing process, such as brew temperature, brew volumes, bypass percentages, pulse brew, etc. Other features are Energy Savings mode, Freshness Timer and Clean Alert.

## CONTENTS

Warranty .....	2
Table of Contents .....	3
Troubleshooting .....	4
Service Tools.....	15
Component Access .....	18
Control Board .....	18
Membrane Switch.....	19
Dispense and Bypass Valves.....	20
Refill Valves .....	21
Tank Heaters .....	22
Temperature Probe .....	23
Limit Thermostats .....	22
Contactor .....	23
Main Power Switch.....	24
Schematic (Wiring Diagram).....	25

## TROUBLESHOOTING

A troubleshooting guide is provided to suggest probable causes and remedies for the most likely problems encountered. If the problem remains after exhausting the troubleshooting steps, contact the Bunn-O-Matic Technical Service Department.

- Inspection, testing, and repair of electrical equipment should be performed only by qualified service personnel.
- All electronic components have 120-240 volt ac and low voltage dc potential on their terminals. Shorting of terminals or the application of external voltages may result in board failure.
- Intermittent operation of electronic circuit boards is unlikely. Board failure will normally be permanent. If an intermittent condition is encountered, the cause will likely be a switch contact or a loose connection at a terminal or crimp.
- Solenoid removal requires interrupting the water supply to the valve. Damage may result if solenoids are energized for more than ten minutes without a supply of water.
- The use of two wrenches is recommended whenever plumbing fittings are tightened or loosened. This will help to avoid twists and kinks in the tubing.
- Make certain that all plumbing connections are sealed and electrical connections tight and isolated.
- This brewer is heated at all times. Keep away from combustibles.

- WARNING** –
- Exercise extreme caution when servicing electrical equipment.
  - Unplug the brewer when servicing, except when electrical tests are specified.
  - Follow recommended service procedures.
  - Replace all protective shields or safety notices.

## TROUBLESHOOTING (cont.)

<u>PROBLEM</u>	<u>PROBABLE CAUSE</u>	<u>REMEDY</u>
Temperature Too Low	1. Water temperature in the tank does not meet the ready temperature.	A) Wait for the brewer to heat to the proper temperature.  B) Disable the <b>BREW LOCKOUT</b> function. Refer to Programming Manual for procedure.
Heating Time Too Long	1. Tank Heater failure.  2. Control Board/Thermistor failure	Service required  Service required
Fill Time Too Long	1. Water shut off to brewer  2. Inlet Solenoid failure  3. Control Board failure  4. ON/OFF switch is OFF	Check water supply shut-off  Service Required  Service Required  Turn switch ON
Temp Sensor Out Of Range, Check For Bad Connections	1. Temperature Sensor Probe wire(s) broken or not making connection	Check wire and connection of both black and white wires of temperature probe.
Temp Sensor Out Of Range, Check Wire For Shorts	1. Temperature Sensor Probe wire(s) shorted to housing or to each other.	Check to confirm that wire(s) are not pinched between two surfaces or connected to each other.
Equipment will not operate	1. No power or incorrect voltage	Measure the voltage at the terminal block and confirm that it matches the voltage specified on the brewer data plate withing +/- 10%.

## TROUBLESHOOTING (cont.)

<u>PROBLEM</u>	<u>PROBABLE CAUSE</u>	<u>REMEDY</u>
Brew cycle will not start	1. No water	Check plumbing and shut-off valves
	2. No power or incorrect voltage to the brewer	Check for voltage across the terminals at the terminal block.
	3. ON/OFF switch	Test the ON/OFF switch. Refer to the test switch procedures on page 17.
	4. Brew switch	Test the BREW switch. Refer to the test switch procedures on page 17.
	5. Brew valve	Test the brew valve. Refer to the test outputs procedures on page 15.
	6. Control Board	Substitute a control board known to be in good working order.

## TROUBLESHOOTING (cont.)

<u>PROBLEM</u>	<u>PROBABLE CAUSE</u>	<u>REMEDY</u>
Automatic refill will not operate or display shows FILL TIME TOO LONG	<ol style="list-style-type: none"><li>1. No water</li><li>2. Refill valve</li><li>3. Refill probe or Sensitivity setting</li></ol>	<p>Check plumbing and shut-off valves</p> <p>Remove the strainer and check for obstructions. Clear or replace.</p> <p>Check the sensitivity setting. Refer to the <b>REFILL</b> function in Programming Manual. If the left three digit number is less than the right number, the machine “thinks” it is full and the refill valve should be off. If the left number is larger than the right, then the refill valve will automatically be turned on to fill the tank. The right number is the threshold setting and can be adjusted to compensate for extreme water conditions: very pure, low conductance water requires a higher setting, while high mineral content, high conductance water requires a lower setting. Note that the left number changes from a high value when water is NOT touching the refill probe to a low value when water IS touching the probe. For best operation, the right number should be set to a value midway between these low and high numbers. Before changing the setting, confirm that the refill probe is free of scale buildup and the connection to it is secure. Test the refill valve. Refer to the test outputs procedures on page 15.</p>

## TROUBLESHOOTING (cont.)

<u>PROBLEM</u>	<u>PROBABLE CAUSE</u>	<u>REMEDY</u>
Automatic refill will not operate or display shows FILL TIME TOO LONG (Continued)		Refill valve – Disconnect the brewer from the power source and remove wires from refill valve coil. Check for continuity across the terminals of the solenoid coil. If continuity is not present, replace the refill valve. If continuity is present, the coil may be stuck closed. Shut water off to brewer. Press the ON/OFF switch to turn off the brewer. Open the faucet and drain water down in the tank until flow stops or slows to a trickle. Attach a voltmeter to the terminals of the refill solenoid. Connect the brewer to the power source. Press the ON/OFF switch to turn the brewer on. Within five seconds, voltage should be present at the solenoid terminals. If voltage is not present, refer to the wiring schematic and check the wiring harness.
	4. Control Board	Substitute a control board known to be in good working order.
	5. ON/OFF Switch	ON/OFF switch must be ON for the refill circuit to operate. Turn ON.
	6. Overflow Safety Switch	When this condition occurs, the brewer will display OVERFLOW CUP FULL. EMPTY CUP. The reason for overfilling could be a defective refill valve, an incorrect sensitivity setting, (see above) or boiling.



## TROUBLESHOOTING (cont.)

<u>PROBLEM</u>	<u>PROBABLE CAUSE</u>	<u>REMEDY</u>
Water flows into tank continuously with power removed from brewer.	<ol style="list-style-type: none"><li>1. Refill valve</li><li>2. Refill probe or sensitivity setting</li></ol>	<p>Foreign material lodged in valve, holding it in open state.</p> <p>Check the sensitivity setting. Refer to the <b>REFILL</b> function in Programming Manual. If the left three digit number is less than the right number, the machine “thinks” it is full and the refill valve should be off. If the left number is larger than the right, then the refill valve will automatically be turned on to fill the tank. The right number is the threshold setting and can be adjusted to compensate for extreme water conditions: very pure, low conductance water requires a higher setting, while high mineral content, high conductance water requires a lower setting. Note that the left number changes from a high value when water is NOT touching the refill probe to a low value when water IS touching the probe. For best operation, the right number should be set to a value midway between these low and high numbers. Before changing the setting, confirm that the refill probe is free of scale buildup and the connection to it is secure.</p>
	<ol style="list-style-type: none"><li>3. Control Board</li></ol>	<p>Substitute a control board known to be in good working order.</p>

## TROUBLESHOOTING (cont.)

PROBLEM	PROBABLE CAUSE	REMEDY
Water will not heat or display shows HEATING TIME TOO LONG.	1. Limit Thermostats	Remove power from the brewer. Check for continuity through the limit thermostat. <b>CAUTION:</b> Do not eliminate or bypass limit thermostat. Use only replacement part 23717.0003.
	2. Temperature probe	Remove the probe from the grommet and submerge in a water bath of approximately 70°F (21°C). Connect an ohmmeter to the pins in the connector. At 60°F (16°C), the reading should be 15.3k ± 2k OHMS, at 70°F (21°C) the reading should be 11.8k ± 2k OHMS, and at 80°F (27°C) the reading should be 9.3k ± 2k OHMS. If the probe is within these parameters, reconnect to the control board.
	3. Tank heaters	Remove power from the brewer. Check for continuity through the tank heaters. If no continuity is present, check for a wiring problem (consult wiring schematic), then replace the tank heater if no wiring problem is found.
	4. Control Board	Remove power from the brewer. Connect a voltmeter across the tank heater. Reapply power to the brewer and refer to testing outputs on page 15. If the voltage measured when the tank heater is turned on is very low or zero, then substitute a control board known to be good working order.

## TROUBLESHOOTING (cont.)

<u>PROBLEM</u>	<u>PROBABLE CAUSE</u>	<u>REMEDY</u>
No bypass water	1. Bypass valve	Test the bypass valve. Refer to the test outputs procedures on page 15.
Spitting or unusual steaming from sprayhead or air vent.	1. Lime buildup	Inspect the probe and tank assembly for excessive lime deposits. Delime as required.
	2. Temperature probe	Remove the probe from the grommet and submerge in a water bath of approximately 70°F (21°C). Connect an ohmmeter to the pins in the connector. At 60°F (16°C), the reading should be 15.3k ± 2k OHMS, at 70°F (21°C) the reading should be 11.8k ± 2k OHMS, and at 80°F (27°C) the reading should be 9.3k ± 2k OHMS. If the probe is within these parameters, reconnect to the control board.
	3. Control Board	Remove power from the brewer. Connect a voltmeter across the tank heater. Reapply power to the brewer and refer to testing outputs on page 15. If the voltage measured when the tank heater is turned on is very low or zero, then substitute a control board known to be good working order.

## TROUBLESHOOTING (cont.)

<u>PROBLEM</u>	<u>PROBABLE CAUSE</u>	<u>REMEDY</u>
Inconsistent beverage level in server/dispenser	1. Improper water pressure	Check operating water pressure to the brewer. It must be between 20 and 90 psi (138 and 620 kPa).
	2. Brew valve	Test the brew valve. Refer to test outputs on page 15. Turn the valve on for 30 seconds and collect the water dispensed from the spray-head. Repeat the test several times to confirm a consistent volume of dispensed water. If not consistent, check the valve, tubing and spray-head for lime buildup.
	3. Bypass valve	If bypass is being used on the inconsistent brew, test the bypass valve. Refer to test outputs on page 15. Turn the valve on for 30 seconds and collect the water collected from the funnel. Repeat the test several times to confirm a consistent volume of dispensed water. If not consistent, check the valve, tubing and fittings for lime buildup.
	4. Lime buildup	Inspect for lime buildup that could block the tank, tank fittings, tubing, valves and sprayhead.
	5. Brew volume adjustment	Adjust the brew volume, calibrate sprayhead and bypass as required to achieve the desired volume for each brew cycle.

## TROUBLESHOOTING (cont.)

<u>PROBLEM</u>	<u>PROBABLE CAUSE</u>	<u>REMEDY</u>
Dripping from sprayhead.	1. Brew valve	Repair or replace leaky valve
Water overflows filter.	1. Type of paper filter	BUNN paper filters should be used for proper extraction
	2. No sprayhead	Check sprayhead
Beverage overflows server.	1. Beverage left in server from previous brew	The brew cycle should be started only with an empty server under the funnel.
	2. Brew volume adjustment	Adjust the brew volume, calibrate sprayhead and bypass as required to achieve the desired volume for each brew cycle
Brewer is making unusual noises.	1. Solenoids	The mounting screws on the solenoids must be tight or they will vibrate during operation
	2. Plumbing lines	Plumbing lines should not be resting on the countertop.
	3. Water supply	The brewer must be connected to a cold water line. Water pressure to the brewer must not be higher than 90 psi (620 kPa). Install a regulator if necessary to lower the working pressure to approximately 50 psi (345 kPa).
	4. Tank heaters	Remove and clean lime off tank heaters.

## TROUBLESHOOTING (cont.)

<u>PROBLEM</u>	<u>PROBABLE CAUSE</u>	<u>REMEDY</u>
Weak beverage.	1. Type of paper filter	BUNN paper filters should be used for proper extraction
	2. Coffee	A sufficient quantity of fresh drip or regular grind should be used for proper extraction.
	3. Sprayhead	Bunn-O-Matic sprayhead should be used to properly wet the bed of ground coffee in the funnel
	4. Funnel Loading	The BUNN paper filter should be centered in the funnel and the bed of grounds leveled by gently shaking. Use the four wire loops on the funnel to hold filter in place while brewing.
	5. Water temperature	Empty the server, remove its cover, and place the server beneath the sprayhead. Place empty funnel over the server entrance (not in the funnel rails). Press brew. Check the water temperature immediately below the sprayhead with a thermometer. The reading should not be less than 195°F (90°C).

## TROUBLESHOOTING (cont.)

### SERVICE TOOLS

This function allows the testing of individual components and the ability to check switches for proper function.

#### Procedure to test components and outputs:

The following components can be individually tested:

#### SINGLE Brewers

Brew Valve  
Bypass Valve  
Funnel Lock  
Refill Valve  
Tank Heater Relay

#### DUAL Brewers

Left Brew Valve  
Left Bypass Valve  
Left Funnel Lock  
Right Brew Valve  
Right Bypass Valve  
Right Funnel Lock  
Refill Valve  
Tank Heater Relay

#### Procedure to test components (outputs):

1. Place brew funnel(s) into rails on the brewer (both sides on DUAL brewers).
2. Place a server(s) beneath the brew funnel(s).
3. Press and hold the right hidden button until the display reads **SET LANGUAGE**. Press the right hidden button until the display reads **SERVICE TOOLS**.
4. Press and release **YES**. The display should now read **TEST OUTPUTS?** Press and release **YES** to test individual components and outputs. Pressing **NO** will advance to the next programming function, **TEST SWITCHES**.
5. The display should now read:  
**BREW VALVE** on SINGLE brewers  
**<- <- BREW VALVE** on DUAL brewers.  
To test the brew valve, press **ON**. If the brew valve is functional, water should run from the funnel (left side on DUAL brewers).
6. Press **OFF** to end the flow of water.

7. Press **NEXT** to advance to the next component to be tested.

**NOTE:** To bypass testing any component, press **NEXT** to advance to the next component without testing the previous one.

8. The display should now read:  
**BYPASS VALVE** on SINGLE brewers  
**<- <- BYPASS VALVE** on DUAL brewers  
To test the left bypass valve, press **ON**. If the bypass valve is functional, water should run from the funnel (left funnel on DUAL brewers).
9. Press **OFF** to end the flow of water.
10. Press **NEXT** to advance to the next component to be tested.
11. To test **FUNNEL LOCK** on SINGLE brewers or **LEFT FUNNEL LOCK** on DUAL brewers, press **ON**. If the funnel lock is functional, the lock will come down to hold the funnel in place.
12. Press **OFF** to retract the funnel lock.
13. For DUAL brewers, follow steps 5-12 to test the right side components.
14. To test the **REFILL VALVE**, press **ON**. If the refill valve is functional, the sound of the valve operating will be heard.
15. Press **OFF** to end testing of the refill valve.
16. Press **NEXT** to advance to the next component to be tested, **TANK HEATR RELAY**.
17. To test the tank heater relay, connect a voltmeter across each of the tank heaters to check for voltage.
18. Press **ON**. The correct voltage should be present at the heater terminals.
19. Press **OFF** to end testing of the tank heater relay.

**NOTE:** The tank heater will automatically turn off if left on too long.

20. Press **NEXT** to return to the **TEST OUTPUTS** screen. To advance to the next function screen, **TEST SWITCHES**, press **NO**. To exit programming, press and release the ON/OFF switch (either on DUAL brewers) to return to the **MAIN SCREEN**.

# TROUBLESHOOTING (cont.)

## SERVICE TOOLS (cont.)

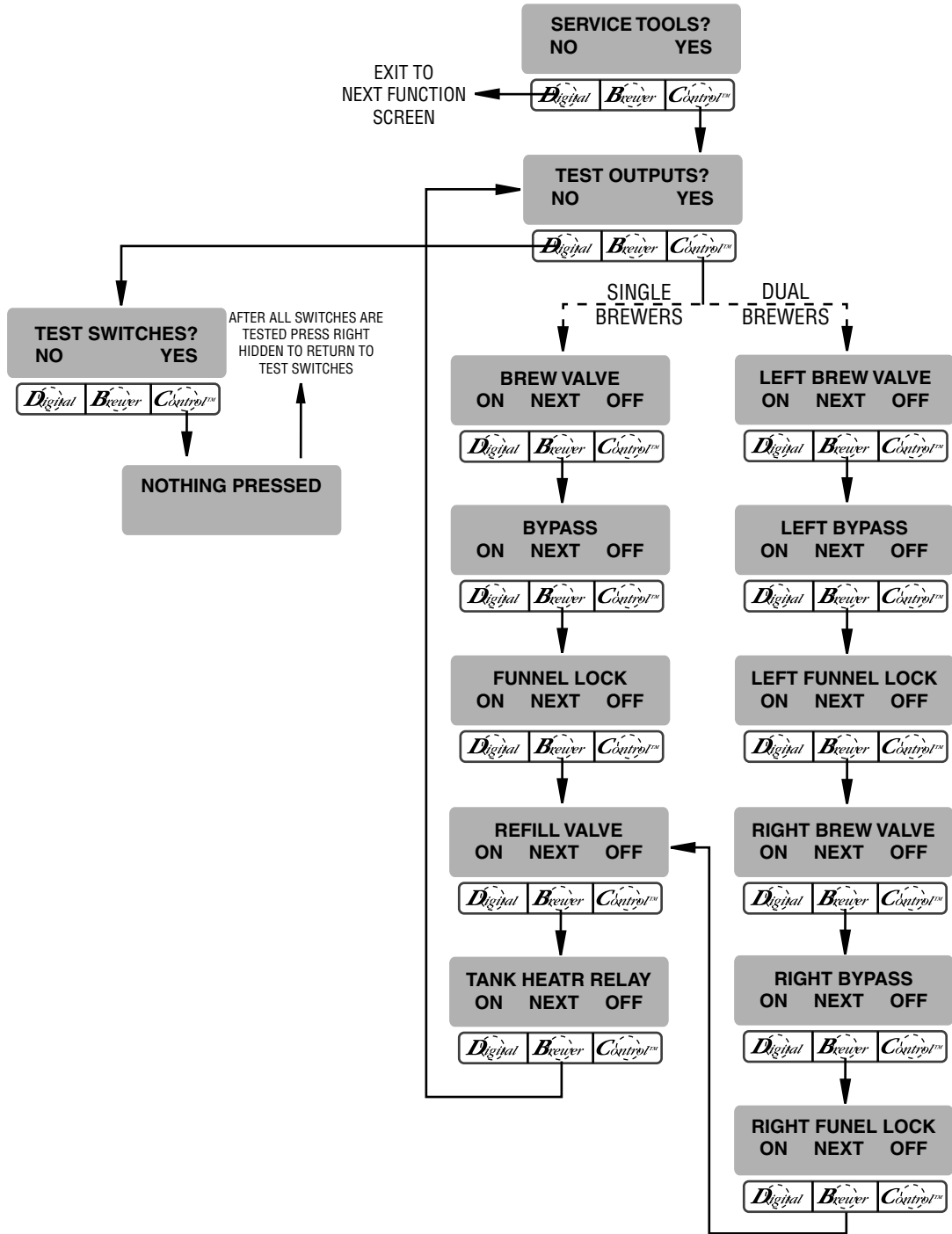



## TROUBLESHOOTING (cont.)

### SERVICE TOOLS (cont.)

#### Procedure to test switches:

This function allows the operator to test the operation of the individual switches on the front panel. The following switches can be individually tested:

#### SINGLE Brewers:

Full Batch  
Half Batch  
Power  
Brew Switch  
Left Hidden  
DONE  
(-)  
(+)

#### DUAL Brewers:

<- <- Full Batch	Full Batch -> ->
<- <- Half Batch	Half Batch -> ->
<- <- Power	Power -> ->
<- <- Brew Switch	Brew Switch -> ->
Left Hidden	DONE
(-)	(+)

1. Place brew funnel(s) into rails on the brewer (both sides on DUAL brewers).
2. Place server(s) beneath the brew funnel(s).
3. Press and hold the upper right hidden switch until display reads **SET LANGUAGE**. Release the switch. Continue to press and release switch until **SERVICE TOOLS** appears.
4. Press and release **YES**. The display should read **TEST OUTPUTS?**. Press and release **NO** to advance to **TEST SWITCHES**.
5. Pressing **NO** in this screen will advance to the next function. Press **YES** in the **TEST SWITCHES** screen to test the switches. The display will read **NOTHING PRESSED**.
6. From this screen, press any of the switches on the front of the brewer except the upper right hidden switch. While the switch is pressed, the display shows the name of that switch. If the name does not appear, or if it remains after the switch has been released, the switch is defective. Each switch can be tested in this manner.
7. After all switches have been tested, press and release the right hidden switch (®). This will return to **TEST SWITCHES?**. To exit programming, press

and release the ON/OFF switch (either on DUAL brewers) located on the front switch panel. This will exit **TEST SWITCHES** and return to the **MAIN SCREEN**.

**NOTE:** If the operator wishes to test more than one function in the **SERVICE TOOLS** section (outputs or switches), it is not necessary to exit the program. Use the flow chart for **SERVICE TOOLS** to navigate to a particular function.

## COMPONENT ACCESS

This section provides procedures for testing and replacing various major components used in this brewer should service become necessary. Refer to Troubleshooting for assistance in determining the cause of any problem.

**WARNING** - Inspection, testing, and repair of electrical equipment should be performed only by qualified service personnel. The brewer should be disconnected from power source when servicing, except when electrical tests are required and the test procedure specifically states to plug in the brewer.

**WARNING** - Disconnect the brewer from the power source before the removal of any panel or the replacement of any component.

All components are accessible by the removal of the top cover, front access panel.

**Refer to wiring diagrams at the back of this manual when reconnecting wires.**

## CONTROL BOARD

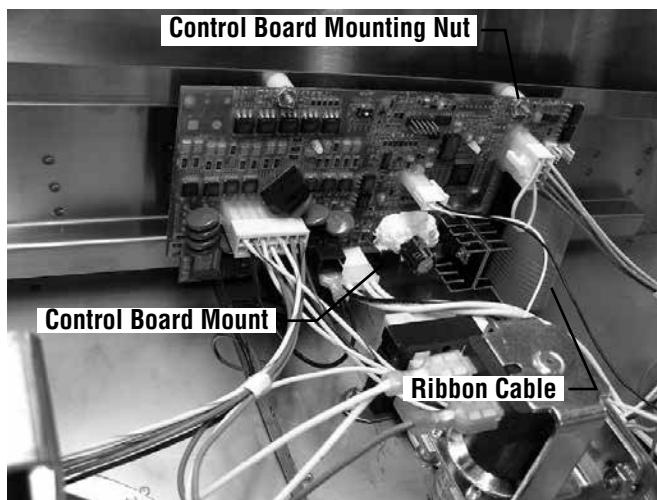

**FIG 1 CONTROL BOARD MOUNTING**

### Location:

The Control Board (Fig 1) is located under the top cover behind the control panel.

### Check for Power to board:

1. Insert one meter lead in J17-pin 9 and the other lead in J17-pin 11.
2. With the power connected to brewer, the voltage reading to the board should be the line voltage rated for that model.

**If no voltage is present, check wiring to the board. If voltage is present, and brewer does not power on, replace board.**

### Removal and Replacement:

1. Disconnect brewer from power source.
2. Disconnect the main harness from the 14 pin connector J17 on the control board.
3. Disconnect the ribbon cable from connector J2 on the control board.
4. Disconnect the temperature probe harness from connector J13 on the control board.
5. Disconnect level probe and overflow cup from the 8 pin connector J3 on the control board.
6. Disconnect transformer from connector J15 on the control board.
7. Remove the two mounting nuts securing the top of the control board to the hood.
8. Tilt the control board inward to clear the display section and lift out of the control board mount.
9. Place the bottom edge of the new control board in the control board mount, tilt the board forward, and secure with the two keps nuts.
10. Re-connect wires to the circuit board.

## COMPONENT ACCESS (cont)

### MEMBRANE SWITCH



**FIG 2 MEMBRANE SWITCH**

#### Location:

The Membrane Switch (Fig 2) is located on the front of the hood with a ribbon cable extending through the hood and connected to the control board.

#### Test Procedures:

There are two methods for testing the membrane switch. The easiest method is to use the built in test mode. Refer to the Trouble Shooting Section for Service Tools/Test Switches. If for some reason you can't get into the program modes, or brewer won't power up, you can test it with an ohmmeter or continuity tester. Refer to the schematic to trace the appropriate pins.

**NOTE:** Pin 1 is the static shield & will not provide a reading to the other pins. There are three commons in this circuit, pins #9, 10 & 21.

Disconnect brewer from power source before disconnecting ribbon cable from control board.

#### Removal and Replacement:

1. Disconnect the ribbon cable from 22-pin connector on the control board.
2. Gently peel the membrane switch from the hood.
3. Remove any adhesive that remains on the hood.

4. Remove the adhesive backing from the new membrane switch. Insert the ribbon cable through the slot in the hood and apply the membrane switch to the front of the hood.
5. Reconnect the ribbon cable to the 22-pin connector on the control board making sure every pin on the control board is inserted into the ribbon cable connector.

## COMPONENT ACCESS (cont)

### BYPASS VALVES

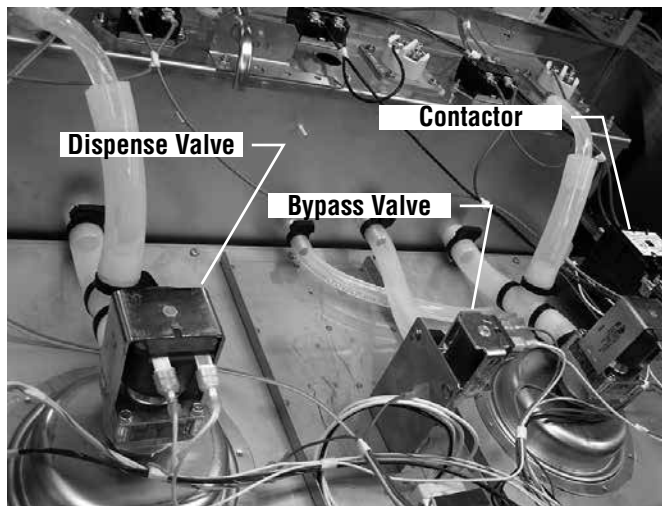

**FIG 3 BYPASS/DISPENSE VALVES**

#### Location:

The bypass valve(s) (Fig 3) are located inside the hood under the top cover.

#### Test Procedures:

1. Refer to the Trouble Shooting Section for Service Tools/Test Outputs/Bypass Valve.
2. Be sure brew funnel & server are in place before activating valve.
3. Check the valve for coil action. Turn on the valve with the test mode. Listen carefully in the vicinity of the bypass valve for a click as the coil pulls the plunger in.

If no sound is heard as described, proceed to #4.

If the sound is heard as described, there may be a blockage in the valve, hose, or tank. Disconnect the brewer from the power source. Remove the valve and inspect for blockage, and de-lime all related areas.

4. Connect the voltmeter leads to the coil terminals. Turn on the valve with the test mode. **NOTE: Due to the internally rectified coil, the indication will be 120VAC all the time.** Set the meter to DC volts. The indication should be 170VDC when activated. If the polarity of meter leads are reversed, reading will indicate -170VDC. (Double these readings for 240 volt coils)

If voltage is present as described, but no coil action is observed, valve is defective. Replace valve and test again to verify repair.

If voltage is not present as described, refer to Wiring Diagrams and check the brewer wiring harness. Also check the control board and switch for proper operation.

#### Removal and Replacement:

1. Disconnect the brewer from the power source.
2. Disconnect wires from the valve.
3. Drain enough water from the tank so the water level is below the outlet.
4. Remove tube(s) from the valve.
5. Remove the two #8-32 nuts mounting valve to the bracket.
6. Install new valve using nut(s) removed in step 5.
7. Reconnect tube(s) to the valve and secure in place with clamp(s).

### DISPENSE VALVES

#### Location:

The dispense valve(s) (Fig 3) are located inside the hood under the top cover.

#### Test Procedures:

1. Refer to the Trouble Shooting Section for Service Tools/Test Outputs/Dispense Valve.
2. Be sure brew funnel & server are in place before activating valve.
3. Check the valve for coil action. Turn on the valve with the test mode. Listen carefully in the vicinity of the dispense valve for a click as the coil pulls the plunger in.

If no sound is heard as described, proceed to #4.

If the sound is heard as described, there may be a blockage in the valve, hose, tank, or sprayhead. Disconnect the brewer from the power source. Remove the valve and inspect for blockage, and de-lime all related areas.

## COMPONENT ACCESS (cont)

### DISPENSE VALVES (cont)

4. Connect the voltmeter leads to the coil terminals. Set the meter to AC volts. Turn on the valve with the test mode. The indication should be the line voltage rated for that model.

If voltage is present as described, but no coil action is observed, valve is defective. Replace valve and test again to verify repair.

If voltage is not present as described, refer to Wiring Diagrams and check the brewer wiring harness. Also check the control board and switch for proper operation.

#### Removal and Replacement:

1. Disconnect the brewer from the power source.
2. Disconnect wires from the valve.
3. Drain enough water from the tank so the water level is below the outlet.
4. Remove tube from the valve.
5. Remove the sprayhead and nut securing valve to the sprayhead panel.
6. Install new valve using nut removed in step 5. Clean and install the sprayhead.
7. Reconnect tube to the valve and secure in place with clamp.

### REFILL VALVE

#### Location:

The refill valve (Fig 4) is located inside the front of the brewer behind the front access panel.

#### Test Procedures:

1. Enter programming level 2, scroll to "Service Tools" then scroll to "Refill Valve".
2. Briefly activate the refill valve in the test mode. With a voltmeter, check the voltage across the coil wires.
3. The indication must be 120 volts ac for 120/208 and 120/240 volt models or 230 volts ac for 230/400 volt models.

If voltage is present, proceed to # 4.



**FIG 4 REFILL VALVE**

If voltage is not present, refer to Wiring Diagrams and check main wiring harness. If harness checks ok, replace control board.

4. Check the refill valve for coil action. Briefly activate the refill valve in the test mode and listen carefully near the refill valve for a "clicking" sound as the magnetic coil pulls the plunger in.

If the sound is heard as described and water will not pass through the refill valve, there may be a blockage in the water line before the refill valve or, the solenoid valve may require inspection for wear, and removal of waterborne particles.

If the sound is not heard as described, proceed to # 5.

5. Disconnect the brewer from the power source.
6. Check for continuity across the refill valve coil terminals.

If continuity is not present as described, replace the refill valve.

If continuity is present as described, there could be some debris in the valve.

#### Removal and Replacement:

1. Shut off the water supply and drain the tank.
2. Remove both wires from the refill valve.
3. Disconnect both water lines at the valve.



## COMPONENT ACCESS (cont)

### REFILL VALVE (cont)

4. Remove the two 1/4"-20 screws securing the valve to the component mounting bracket.
5. Using the two 1/4"-20 screws, install the new valve to the component mounting bracket.
6. Securely fasten the water lines to the valve.
7. Refer to wiring diagrams when reconnecting the wires.
8. Install access panels and covers and refer to Initial Set-up for refill and operation.

### TANK HEATERS

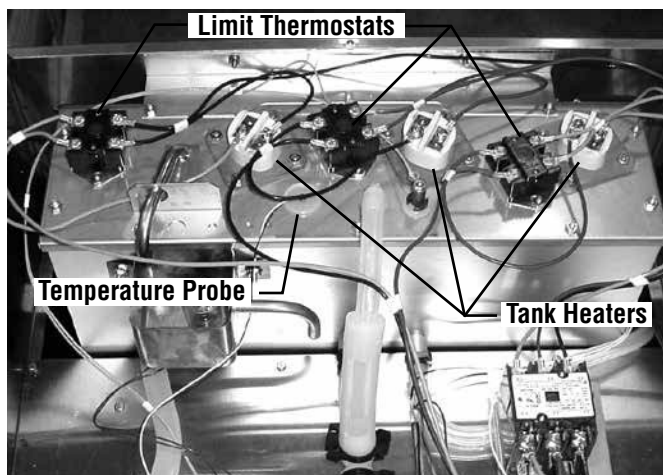

**FIG 5 TANK HEATERS, LIMIT THERMOSTATS, TEMPERATURE PROBE**

#### Location:

The tank heaters (Fig 5) are located inside the tank, secured to the tank lid.

#### Test Procedures:

1. With a voltmeter, check voltage across the two terminals on top of the tank heaters. Connect brewer to the power source. The indication must be 208 volts ac for three wire 120/208 volt models, 240 volts ac for three wire 120/240 volt models, and 230 volts ac for 230/400 volt models (during a heating cycle).
2. Disconnect the brewer from the power source.

If voltage is present as described, proceed to #3.

If voltage is not present as described, refer to the Wiring Diagrams and check wiring harness. If harness checks ok, replace control board.

3. Disconnect the wires from the tank heater terminals.
4. Check resistance value across tank heater terminals and compare to chart.

If resistance is present as described, reconnect the wires, the tank heater is ok.

If resistance is not present as described, replace the tank heater.

NOTE- If any resistance is read between sheath and either terminal, remove and inspect heater for cracks in the sheath.

HEATER	RESISTANCE
4000W-208V	11.0 $\Omega$
4000W-240V	14.47 $\Omega$
TERMINAL TO SHEATH - INFINITE (OPEN)	

#### Removal and Replacement:

1. Remove the top cover from the brewer.
2. Disconnect the wires from tank heater terminals.
3. Remove the four #8-32 nuts securing the tank heater(s) to the tank lid assembly.
4. Remove tank heater(s) with gasket(s) and discard.
5. Install new tank heater(s) with new gasket(s) to the tank lid assembly with the original nuts.
6. Reconnect the wires to the tank heater(s) terminals.

### LIMIT THERMOSTATS

#### Location:

The limit thermostats (Fig 5) are located under the top cover on the tank lid assembly.

#### Test Procedures:

1. Disconnect the brewer from the power source.
2. Disconnect the wires from the limit thermostat.
3. With an ohmmeter, check for continuity across the limit thermostat terminals.

## COMPONENT ACCESS (cont)

### LIMIT THERMOSTATS (cont)

If continuity is present as described, the limit thermostat is operating properly.

If continuity is not present as described, replace the limit thermostat.

#### Removal and Replacement:

1. Remove the wires from limit thermostat terminals.
2. Remove the two #8-32 nuts securing the limit thermostat to the tank lid and lift limit thermostat off the studs.
3. Install the new limit thermostat onto the studs on the tank lid and secure with original nuts.
4. Connect the wires to the limit thermostat.

### TEMPERATURE PROBE

#### Location:

The temperature probe (Fig 5) is inserted into a grommet in the tank lid assembly.

#### Test Procedures:

1. Disconnect the brewer from the power source.
2. With a DC voltmeter, check voltage across the black and white wires at J13 on control board (Black voltmeter probe to black wire, red voltmeter probe to white wire). Connect the brewer to the power source. The indication should be approximately between 4vdc cool to 1vdc at ready temperature.
3. Disconnect the brewer from the power source.

If voltage is present as described, circuit is working correctly, check limit thermostat.

If voltage is not present as described, proceed to #4.

4. Disconnect temperature probe from J13 on control board. Check the resistance across the two terminals of the temperature probe. The indication should be approximately between 10.5K $\Omega$  cool to 870 $\Omega$  at ready temperature.

If resistance is to specification, replace the control board.

If resistance is not to specification, replace the temperature probe.

#### Removal and Replacement:

1. Disconnect the brewer from the power source.
2. Disconnect the temperature probe wires from J13 on the control board and pull probe from grommet in tank lid.
3. Install new temperature probe into grommet and connect wires to J13 on control board,

### CONTACTOR

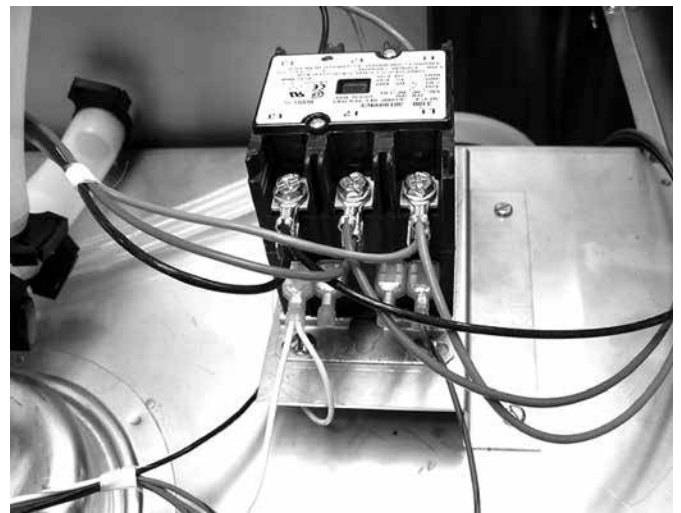

FIG 6 CONTACTOR

#### Location:

The contactor assembly (Fig 6) is located inside the hood under the top cover.

#### Test Procedure:

1. Disconnect the brewer from the power source.
2. Disconnect the white wire and red/black wire from the contactor coil.
3. With a voltmeter, check the voltage across the white wire and red/black wire. Connect the brewer to the power source. The indication must be 120 volts ac for 120/208 and 120/240 volt models or 230 volts ac for 230/400 volt models.
4. Disconnect the brewer from the power source.

If voltage is present as described, proceed to #5.  
If voltage is not present as described, refer to the *Wiring*

## COMPONENT ACCESS (cont)

### CONTACTOR (cont)

*Diagrams* and check the brewer wiring harness.

5. Locate the black, red and blue wires on the L1, L2 and L3 terminals on the contactor.
6. With a voltmeter, carefully check the voltage across L1-L2, L1-L3 and L2-L3. The indication must be, 208 volts ac for 120/208 volt models, 240 volts ac for 120/240 volt models or 230 volts ac for 230/400 volt models.
7. Disconnect the brewer from the power source.

If voltage is present as described, proceed to #8.  
If voltage is not present as described, refer to the *Wiring Diagrams* and check brewer wiring harness.

8. Check for continuity across the terminals on the left side of the contactor by manually closing the contacts. Continuity must not be present when the contact is released.
9. Check for continuity across the terminals in the center of the contactor by manually closing the contacts. Continuity must not be present when the contact is released.
10. Check for continuity across the terminals on the right side of the contactor by manually closing the contacts. Continuity must not be present when the contact is released.

If continuity is present as described, the contactor is operating properly.

If continuity is not present as described, replace the contactor.

#### Removal and Replacement:

1. Remove all wires from the contactor.
2. Remove the four #10-32 slotted head screws securing contactor to the inside of the hood.
3. Securely install the new contactor inside the hood.
4. Connect wires to the contactor terminals.

### POWER SWITCH

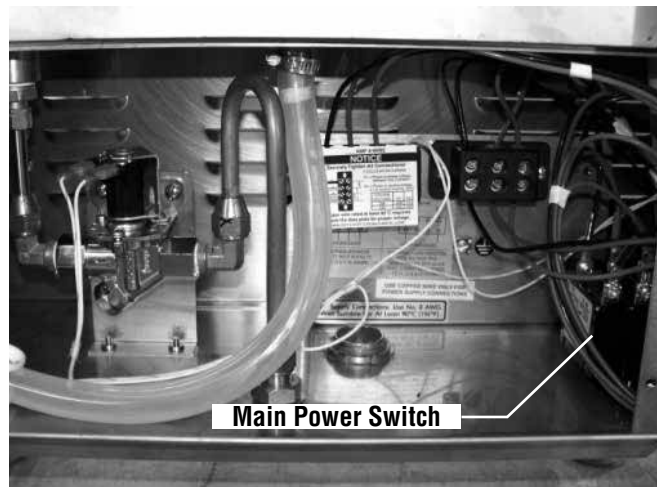

**FIG 7 MAIN POWER SWITCH**

#### Location:

The main power switch is located under the brewer in front of the right rear leg.

#### Test Procedure:

1. Disconnect the brewer from the power source.
2. Disconnect the wires from the power switch. With the switch in the ON position, check for continuity between terminals opposite each other.

There should be continuity between terminals opposite each other when the switch is in the ON position, no continuity when in the OFF position.

If continuity is not present as described, replace the switch.

#### Removal and Replacement:

1. Disconnect the brewer from the power source.
2. Disconnect the wires from the power switch.
3. Remove the switch mounting screws from the under the base.
4. Install new switch in trunk with the two 6-32 x 1/4" mounting screws.
5. Connect wires to the switch terminals.



# SCHEMATIC WIRING DIAGRAM TITAN SINGLE

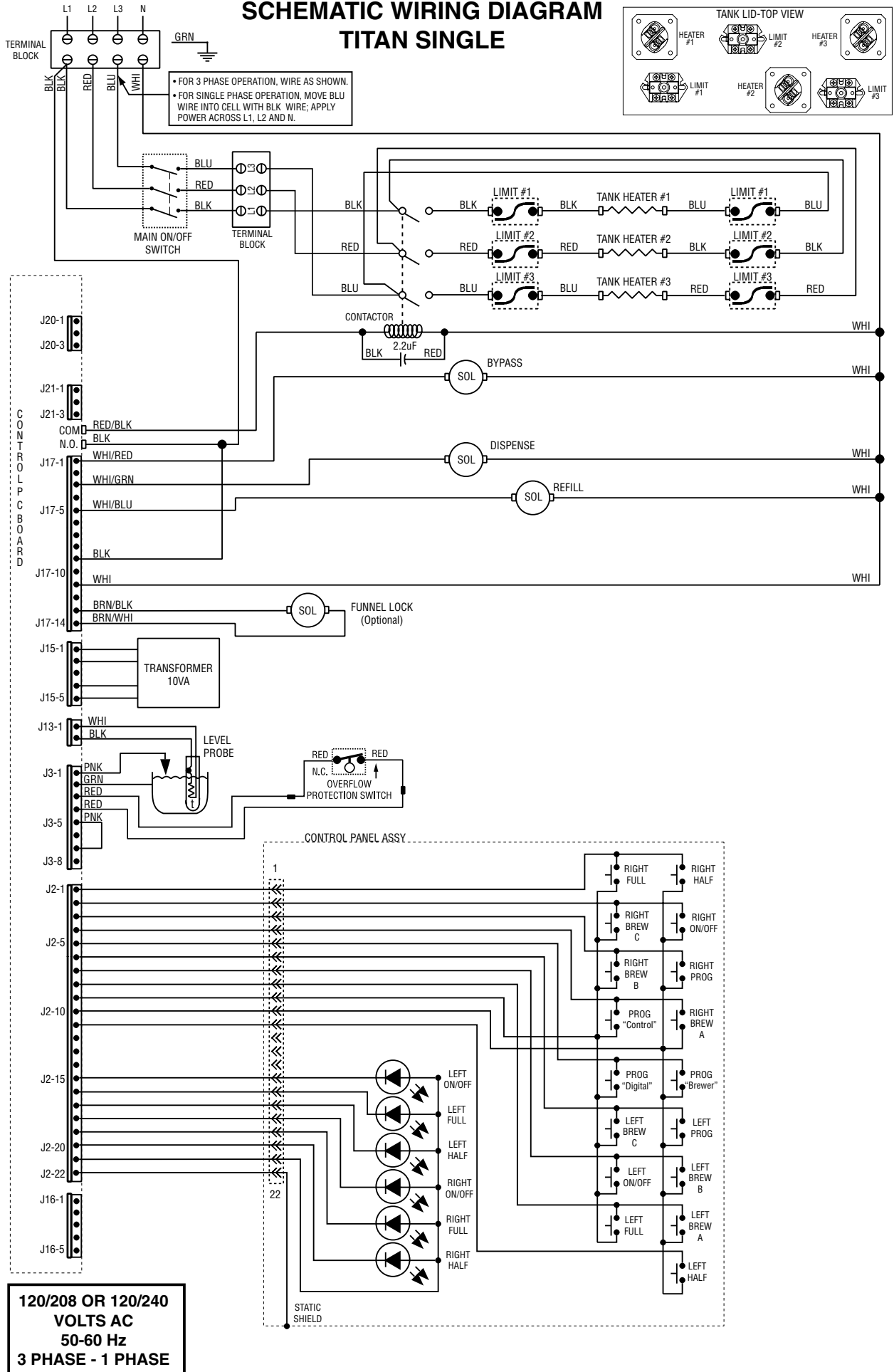

**120/208 OR 120/240  
VOLTS AC  
50-60 Hz  
3 PHASE - 1 PHASE**

# SCHEMATIC WIRING DIAGRAM TITAN SINGLE CE

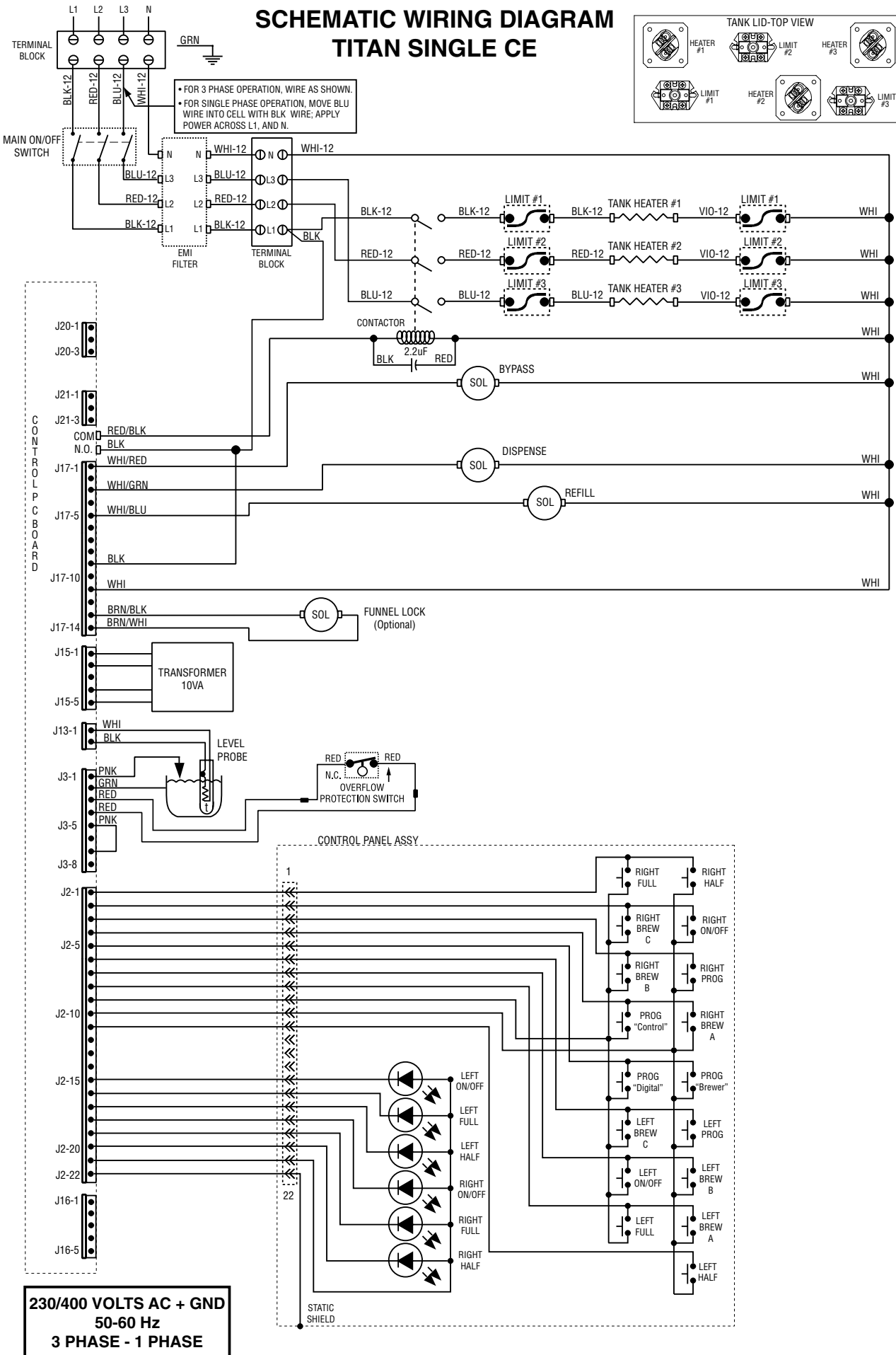
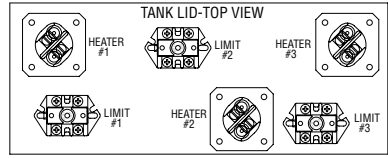

# SCHEMATIC WIRING DIAGRAM TITAN SINGLE

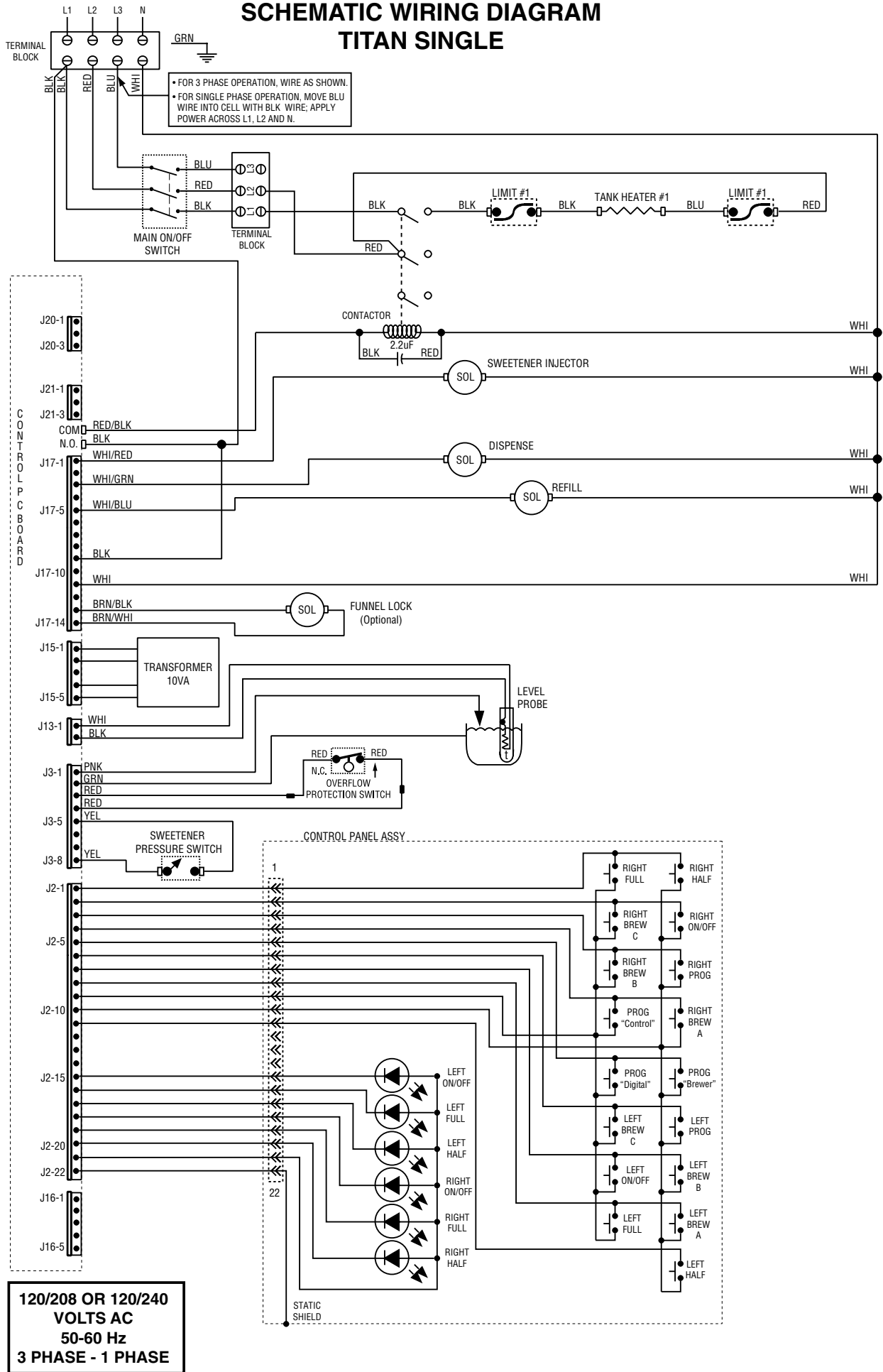

# SCHEMATIC WIRING DIAGRAM TITAN DUAL 200V

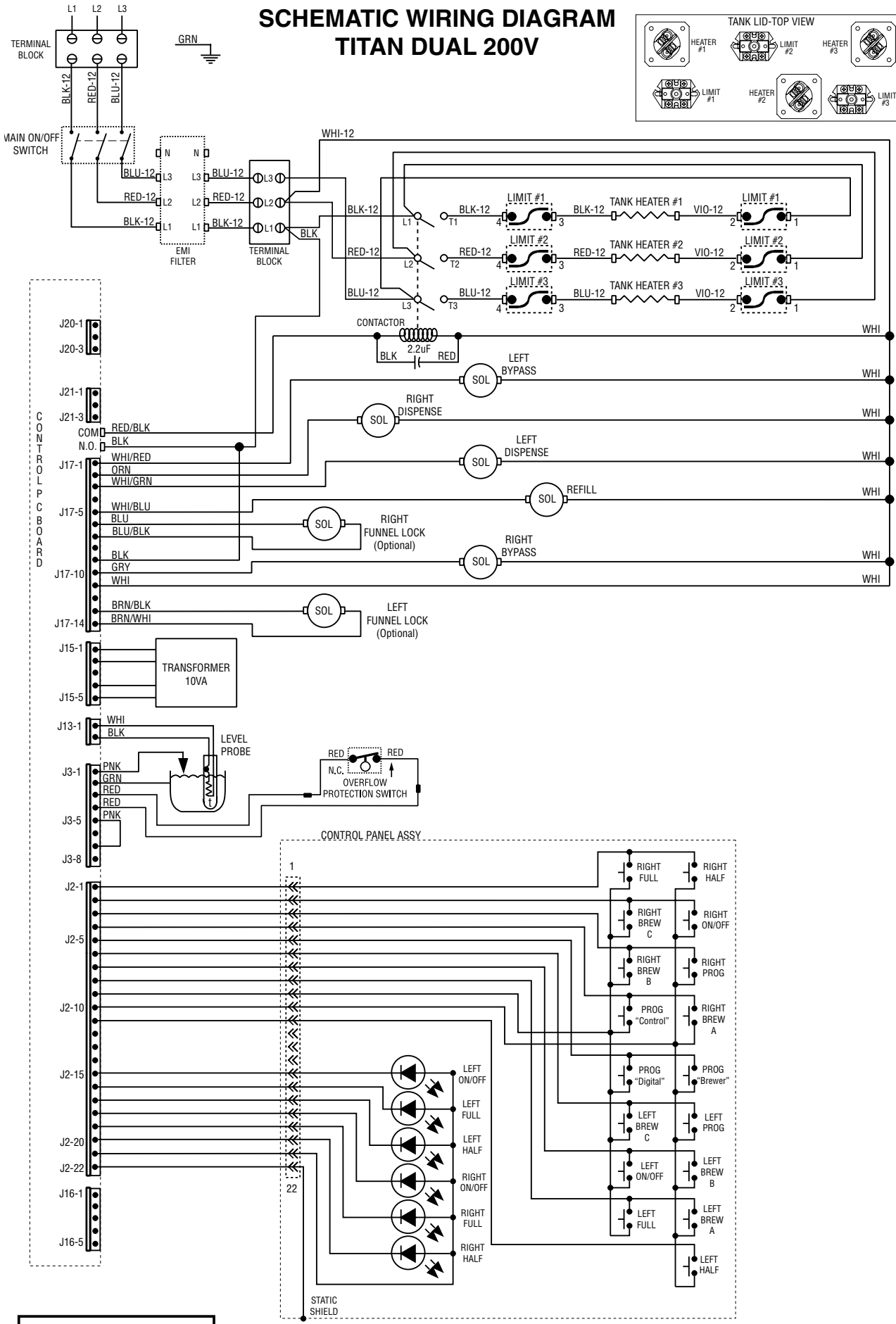
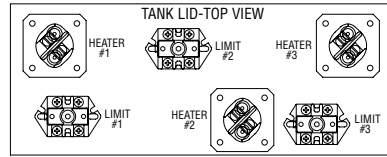

**200 VOLTS AC + GND  
50-60 Hz 3 PHASE**

# SCHEMATIC WIRING DIAGRAM TITAN DUAL CE

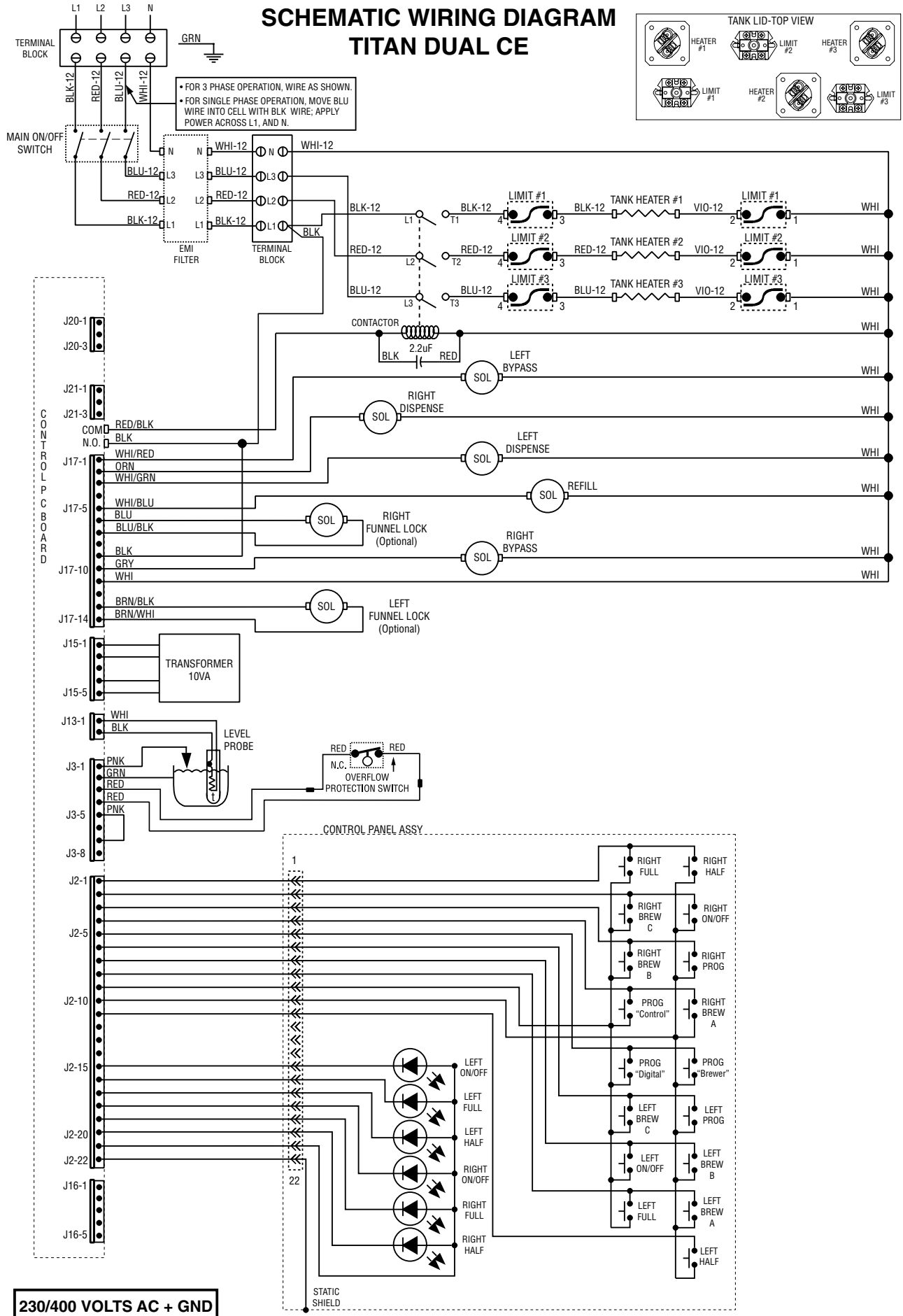

**230/400 VOLTS AC + GND**  
**50-60 Hz**  
**3 PHASE - 1 PHASE**

