

BUNN®

TNT-3

TNTF-3

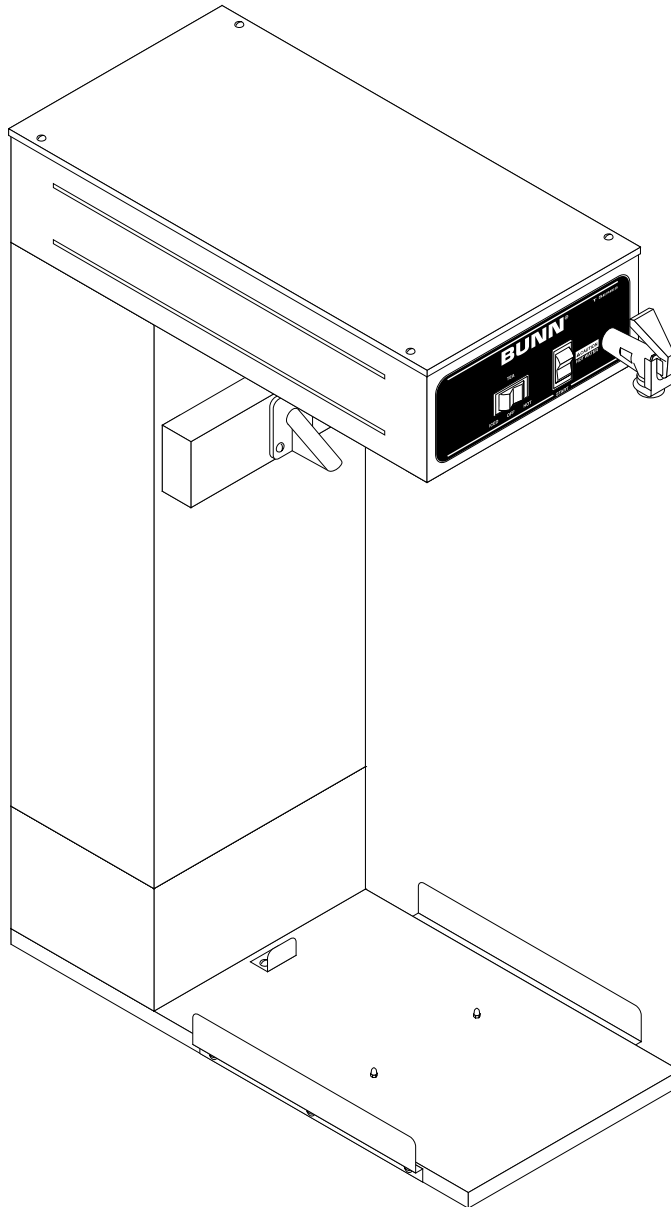

OPERATING & SERVICE MANUAL

BUNN-O-MATIC CORPORATION

POST OFFICE BOX 3227

SPRINGFIELD, ILLINOIS 62708-3227

TELEPHONE: (217) 529-6601 FAX: (217) 529-6644

CONTENTS

Introduction	2
Warranty	2
User Notices	3
Electrical Requirements	4
Plumbing Requirements	4
Initial Set-Up	5
Adjusting Brew Volumes	6
Operating Controls	7
Cleaning	7
Tea Brewing	7
Troubleshooting	8
Service	14
Wiring Diagram	30

INTRODUCTION

This equipment will brew a half-gallon batch of fresh hot tea into an airpot server or three-gallon batch of fresh tea into a dispenser and dispense at approximately room temperature to conserve ice. The brewer is only for indoor use on a sturdy counter or shelf.

WARRANTY

Bunn-O-Matic Corp. (“Bunn”) warrants the equipment manufactured by it to be commercially free from defects in material and workmanship existing at the time of manufacture and appearing within one year from the date of installation. In addition:

- 1.) Bunn warrants electronic circuit and/or control boards to be commercially free from defects in material and workmanship for two years from the date of installation.
- 2.) Bunn warrants the compressor on refrigeration equipment to be commercially free from defects in material and workmanship for two years from the date of installation.
- 3.) Bunn warrants that the grinding burrs on coffee grinding equipment will grind coffee to meet original factory screen sieve analysis for three years from date of installation or for 30,000 pounds of coffee, whichever comes first.

This warranty does not apply to any equipment, component or part that was not manufactured by Bunn or that, in Bunn’s judgement, has been affected by misuse, neglect, alteration, improper installation or operation, improper maintenance or repair, damage or casualty.

THE FOREGOING WARRANTY IS EXCLUSIVE AND IS IN LIEU OF ANY OTHER WARRANTY, WRITTEN OR ORAL, EXPRESS OR IMPLIED, INCLUDING, BUT NOT LIMITED TO, ANY IMPLIED WARRANTY OF EITHER MERCHANTABILITY OR FITNESS FOR A PARTICULAR PURPOSE. The agents, dealers or employees of Bunn are not authorized to make modifications to this warranty or to make additional warranties that are binding on Bunn. Accordingly, statements by such individuals, whether oral or written, do not constitute warranties and should not be relied upon.

The Buyer shall give Bunn prompt notice of any claim to be made under this warranty by telephone at (217) 529-6601 or by writing to Post Office Box 3227, Springfield, Illinois, 62708-3227. If requested by Bunn, the Buyer shall ship the defective equipment prepaid to an authorized Bunn service location. If Bunn determines, in its sole discretion, that the equipment does not conform to the warranty, Bunn shall repair the equipment with no charge for parts during the warranty period and no charge for labor by a Bunn Authorized Service Representative during the warranty period. If Bunn determines that repair is not feasible, Bunn shall, at its sole option, replace the equipment or refund the purchase price for the equipment.

THE BUYER’S REMEDY AGAINST BUNN FOR THE BREACH OF ANY OBLIGATION ARISING OUT OF THE SALE OF THIS EQUIPMENT, WHETHER DERIVED FROM WARRANTY OR OTHERWISE, SHALL BE LIMITED, AS SPECIFIED HEREIN, TO REPAIR OR, AT BUNN’S SOLE OPTION, REPLACEMENT OR REFUND.

In no event shall Bunn be liable for any other damage or loss, including, but not limited to, lost profits, lost sales, loss of use of equipment, claims of Buyer’s customers, cost of capital, cost of down time, cost of substitute equipment, facilities or services, or any other special, incidental or consequential damages.

USER NOTICES

Carefully read and follow all notices on the equipment and in this manual. They were written for your protection. All notices on the equipment should be kept in good condition. Replace any unreadable or damaged labels.

#00831.0000

⚠ WARNING
<ul style="list-style-type: none">◆ Fill water tank before turning -on thermostat or connecting appliance to power source.◆ Use only on a properly protected circuit capable of the rated load.◆ Electrically ground the chassis.◆ Follow national/local electrical codes.◆ Do not use near combustibles.
FAILURE TO COMPLY RISKS EQUIPMENT DAMAGE, FIRE, OR SHOCK HAZARD
READ THE ENTIRE OPERATING MANUAL BEFORE BUYING OR USING THIS PRODUCT
THIS APPLIANCE IS HEATED WHENEVER CONNECTED TO A POWER SOURCE
<small>00831.0000F 3/98 © 1988 BUNN-O-MATIC CORPORATION</small>

#00656.0000

This equipment is to be installed to comply with the Basic Plumbing Code of the Building Officials and Code Administrators International, Inc. (BOCA) and the Food Service Sanitation Manual of the Food and Drug Administration (FDA).

#03408.0000

	⚠ WARNING
	REMOVE FUNNEL SLOWLY

#03409.0000

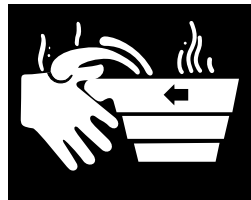
	⚠ WARNING
	HOT LIQUID

ELECTRICAL REQUIREMENTS

CAUTION - The brewer must be disconnected from the power source until specified in *Initial Set-Up*.

120V model brewers require 2-wire, grounded service rated 120 volt ac, 15 amp, single phase, 60 Hz.

120/208V model brewers require 3-wire, grounded service rated 120/208 volt, 20 amp, single phase, 60 Hz.

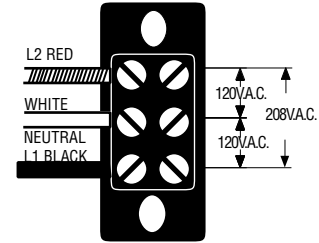

Electrical Hook-Up

CAUTION – Improper electrical installation will damage electronic components.

1. An electrician must provide electrical service as specified.
2. Remove the top lid and rotate the control thermostat knob fully counterclockwise to the "OFF" position.
3. a) 120V brewers have an attached cordset. Plug in the brewer and proceed to #6.
b) 120/208V brewers, feed the cord through the strain relief at the rear of the brewer and connect it to the terminal block.
4. Using a voltmeter, check the voltage and color coding of each conductor at the power source.
5. Connect the brewer to the power source and verify the voltage at the terminal block.
6. If plumbing is to be hooked up later be sure the brewer is disconnected from the power source. If plumbing has been hooked up, the brewer is ready for *Initial Set-Up*.

PLUMBING REQUIREMENTS

These brewers must be connected to a cold water system with operating pressure between 20 (138) and 90 psi (620 kPa) from a ½" or larger supply line. A shut-off valve should be installed in the line before the brewer. Install a regulator in the line when pressure is greater than 90 psi (620 kPa) to reduce it to 50 psi (345 kPa). The water inlet fitting is ¼" flare.

NOTE - Bunn-O-Matic recommends ¼" copper tubing for installations of less than 25 feet and ⅜" for more than 25 feet from the ½" water supply line. A tight coil of copper tubing in the water line will facilitate moving the brewer to clean the countertop. Bunn-O-Matic does not recommend the use of a saddle valve to install the brewer. The size and shape of the hole made in the supply line by this type of device may restrict water flow.

This equipment must be installed to comply with the Basic Plumbing Code of the Building Officials and Code Administrators International, Inc. (BOCA) and the Food Service Sanitation Manual of the Food and Drug Administration (FDA).

PLUMBING REQUIREMENTS (cont.)

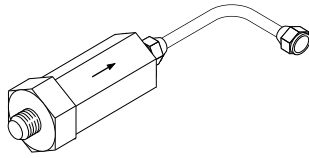

P1394

BREWERS W/OUT FAUCET

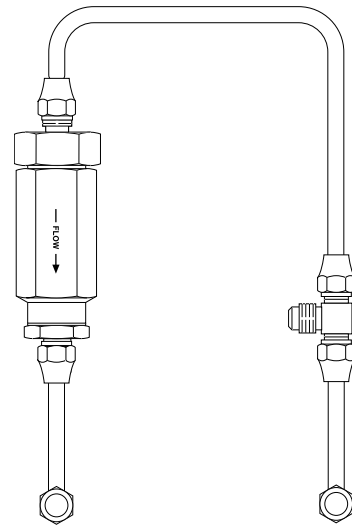

P1392

BREWERS W/FAUCET

1. Remove the shipping cap(s) from the bulkhead fitting(s) on the rear of the brewer.
2. Attach the flare fitting from the short piece of tubing on the strainer/flow control (supplied) to the water inlet fitting(s) at the rear of the brewer.
3. Flush the water line and securely attach it to the flare fitting on the tee or strainer/flow control.
4. Turn on the water supply.
5. On Brewers with a faucet place an empty vessel beneath the faucet and lift the handle until water is dispensed.

INITIAL SET-UP

CAUTION – The brewer must be unplugged throughout the initial set-up, except when specified in the instructions.

1. Remove the top lid from the brewer.
2. Rotate the control thermostat knob fully counterclockwise to the “OFF” position and replace the top lid.
3. Insert the funnel (empty) into the funnel rails.
4. Place an empty tea dispenser on the brewer base. Be prepared to empty the dispenser a few times.
5. Plug in the brewer, place the ICED/OFF/HOT switch in the “HOT” position, and momentarily press the start switch. When the flow of water into the tank stops, press the start switch to initiate a second cycle. Wait until the flow of water stops and start a third cycle.. During the third cycle, the tank will fill to its capacity and the excess will flow from the funnel into the dispenser. Empty the dispenser when this third cycle stops.
6. Place the ICED/OFF/HOT switch in the “ICED” position and begin another brew cycle.
7. Measure the total water volume from the dispenser. It should be approximately (396 ounces.)
8. If not, adjust the Iced Tea timer as required. See *Adjusting Brew Volumes*.
9. Start and measure another cycle.
10. Repeat steps 7-9 until the recommended total water volume (396 ounces) is achieved.
11. The concentrate valve is preadjusted to deliver the correct ratio of brew water to dilution water.
12. Unplug the brewer, remove the top lid, rotate the control thermostat knob fully clockwise to the “ON” position and replace the top lid.

INITIAL SET-UP (cont.)

13. Empty the dispenser.
14. Plug in the brewer and wait for the water in the tank to heat to brewing temperature (approximately 20 minutes). Some water will drip from the funnel during this time; this is due to expansion and should not occur thereafter.
15. Place the ICED/OFF/HOT switch in the “HOT” position and begin another brew cycle. Empty the reservoir after water has stopped flowing from the funnel.
16. Allow the water in the tank to heat to the proper temperature and begin another brew cycle.
17. Measure the total water volume from the dispenser. It should be approximately 64 ounces.
18. If not, adjust the Hot Tea timer as required. See *Adjusting Brew Volumes*.
19. Start and measure another cycle.
20. Repeat steps 17-19 until the recommended total water volume (64 ounces) is achieved.
21. The brewer is now ready to brew approximately one-half gallon of hot tea or 3-gallons of freshly brewed room temperature tea.

ADJUSTING BREW VOLUMES

CAUTION - Disconnect the power source from the brewer prior to the removal of any panel for the replacement or adjustment of any component.

NOTE: Prior to setting or modifying batch sizes, check that the brewer is connected to water supply, the tank is properly filled, and a funnel and server are in place.

1. **Modifying batch sizes.** To modify a batch volume, first check that the SET/LOCK switch is in the “SET” position on the circuit board.
 - To increase a batch size.** Press and hold the START or BREW switch until three clicks are heard. Release the switch (Failure to release the switch within two seconds after the third click causes the volume setting to be aborted and previous volume setting will remain in memory) and press it again one or more times. Each time the switch is pressed, two seconds are added to the brew time period. Allow the brew cycle to finish in order to verify that the desired volume has been achieved.
 - To decrease a batch size.** Press and release the START or BREW switch once for every two-second interval to be removed from the total brew time period; then immediately press and hold down the START or BREW switch until three clicks are heard. Release the switch. (Failure to release the switch within two seconds after the third click causes the volume setting to be aborted and previous volume setting will remain in memory). Allow the brew cycle to finish in order to verify that the desired volume has been achieved.
2. **Setting batch sizes.** To set a batch volume, first check that the SET/LOCK switch is in the “SET” position on the circuit board. Press and hold the START or BREW switch until three distinct clicks are heard, and then release the switch. (Failure to release the switch within two seconds after the third click causes the volume setting to be aborted and previous volume setting will remain in memory). View the level of the liquid being dispensed. When the desired level is reached, turn the ON/OFF switch to “OFF” (lower). The brewer remembers this volume and will continue to brew batches of this size until the volume setting procedure is repeated.

NOTE: When brewing coffee, batch volumes will decrease due to absorption by the coffee grounds.
3. **Setting programming disable feature.** If it becomes necessary to prevent anyone from changing brew times once programmed, you can set the SET/LOCK switch to the “LOCK” position. This will prevent any programming to be done until switch is once again placed in the “SET” position.

CLEANING

CAUTION – Do not keep brewed tea overnight. Clean and sanitize your iced tea dispenser **daily**

1. Remove and thoroughly clean the brew funnel. The funnel tip and screen must be free from any tea particles or residue. Reassemble the funnel.
2. Unplug the brewer. Remove and thoroughly rinse the sprayhead. The holes must be open and clear of any mineral deposits. Wipe the sprayhead panel clean with a damp cloth.
3. Insert the delimiting spring into the sprayhead fitting until no more than one inch is visible and move it in and out 5 or 6 times. Insert the spring into the airvent hole in the sprayhead panel and move it in and out 5 or 6 times. Reattach the sprayhead.
4. Wash the entire outside surface of the brewer with a clean damp cloth.

OPERATING CONTROLS

A. ICED/OFF/HOT Switch

ICED – Placing the switch in the left position allows the start switch to activate a timed brew cycle delivering .5 gallon of tea concentrate and 2.5 gallons of dilution water into the dispenser.

OFF – Placing the switch in the center position stops the brew cycle. Stopping a brew cycle after it has started will not stop the flow of water into the funnel until the tank syphons down to its level. The switch should always be placed in this position after a brew cycle and whenever the brewer is unattended.

HOT – Placing the switch in the right position allows the start switch to activate a timed brew cycle delivering .5 gallon of hot tea into an airpot dispenser.

B. Start Switch

Starts a brew cycle when the ICED/OFF/HOT switch is in either the “ICED” or “HOT” position.

BREWING

1. Begin brewing with a clean empty brew funnel and dispenser. (Be sure the dispenser is open.)
2. Insert a BUNN® filter into the funnel.
3. Pour the fresh loose tea leaves into the filter.
4. Level the bed of tea leaves by gently shaking.
5. Slide the funnel into the funnel rails until it stops.
6. Place the ICED/OFF/HOT switch in the desired position.
7. Momentarily press the start switch.
8. Carefully remove the brew funnel and discard its contents after liquid stops flowing from the funnel.

CAUTION – The funnel contains hot liquid. Remove funnel slowly.

9. Place the ICED/OFF/HOT switch in the “OFF” position to prevent a false start.

TROUBLESHOOTING

A troubleshooting guide is provided to suggest probable causes and remedies for the most likely problems encountered. If the problem remains after exhausting the troubleshooting steps, contact the Bunn-O-Matic Technical Service Department.

- Inspection, testing, and repair of electrical equipment should be performed only by qualified service personnel.
- All electronic components have 120 volt ac and low voltage dc potential on their terminals. Shorting of terminals or the application of external voltages may result in board failure.
- Intermittent operation of electronic circuit boards is unlikely. Board failure will normally be permanent. If an intermittent condition is encountered, the cause will likely be a switch contact or a loose connection at a terminal or crimp.
- Solenoid removal requires interrupting the water supply to the valve. Damage may result if solenoids are energized for more than ten minutes without a supply of water.
- The use of two wrenches is recommended whenever plumbing fittings are tightened or loosened. This will help to avoid twists and kinks in the tubing.
- Make certain that all plumbing connections are sealed and electrical connections tight and isolated.
- This brewer is heated at all times. Keep away from combustibles.

WARNING –

- Exercise extreme caution when servicing electrical equipment.
- Unplug the brewer when servicing, except when electrical tests are specified.
- Follow recommended service procedures
- Replace all protective shields or safety notices

Problem	Probable Cause	Remedy
Brew cycle(s) will not start	1. No water	Water lines and valves to the brewer must be open.
	2. No power or incorrect voltage to the brewer	Check circuit breakers or fuses.
	3. External Strainer/ Flow Control (.750 GPM)	(A) Direction of flow arrow must be pointing towards the brewer. (B) Remove the strainer/flow control and check for obstructions. Clear or replace.
	4. ICED/OFF/HOT Switch	Refer to <i>Service</i> - ICED/OFF/HOT Switch for testing. See page 26
	5. Start Switch	Refer to <i>Service</i> - Start Switch for testing procedures. See page 27

TROUBLESHOOTING (cont.)

PROBLEM

Brew cycle(s) will not start (cont.)

PROBABLE CAUSE

6. Brew Timer
A) Iced Tea

B) Hot Tea

7. Brew Solenoid Valve

A) Iced Tea

B) Hot Tea

8. Internal Flow control (.222 GPM)
(Hot Tea Only)

REMEDY

Refer to *Service* - Brew Timer (Iced Tea) for testing procedures. See page 20 or 21

Refer to *Service* - Brew Timer (Hot Tea) for testing procedures. See page 17 or 18

Refer to *Service* - Brew Solenoid Valve (Iced Tea) for testing procedures. See page 16

Refer to *Service*- Brew Solenoid Valve (Hot Tea) for testing procedures. See page 15

(A) Direction of flow arrow must be pointing towards brewer.

(B) Remove the flow control and check for obstructions. Clear or replace.

Brew water is not hot

1. Limit Thermostat

CAUTION - Do not eliminate or bypass limit thermostat. Use only BOM replacement part #29329.1000

2. Thermal Fuse

CAUTION - Do not eliminate or bypass thermal fuse.

3. Control Thermostat

4. Tank Heater

Refer to *Service* - Limit Thermostat for testing procedures. See page 25

Refer to *Service* - Thermal fuse for testing procedures. See page 29

Refer to *Service* - Control Thermostat for testing procedures. See page 23

Refer to *Service* - Tank Heater for testing procedures. See page 28

Dilution (Iced Tea) cycle will not start

1. ICED/OFF/HOT Switch

Refer to *Service* - ICED/OFF/HOT Switch for testing procedures. See page 26

TROUBLESHOOTING (cont.)

PROBLEM

Dilution (Iced Tea) cycle will not start (cont.)

PROBABLE CAUSE

2. Start Switch

3. Brew Timer (Iced Tea)

4. Brew Solenoid Valve (Iced Tea)

5. Dilution Solenoid Valve

REMEDY

Refer to *Service* - Start Switch for testing procedures. See page 27

Refer to *Service*- Brew Timer (Iced Tea) for testing procedures. See page 20 or 21

Refer to *Service* - Brew Solenoid Valve (Iced Tea) for testing procedures. See page 16

Refer to *Service* - Dilution Solenoid Valve for testing procedures. See page 24

Inconsistent beverage level in dispenser (Hot Tea)

1. Internal Flow Control (.222 GPM)

(A) Direction of flow arrow must be pointing towards the brewer.

(B) Remove the flow control and check for obstruction. Clear or replace.

2. Syphon System

The brewer must be level or slightly lower in front to syphon properly.

3. Lime Build-up

CAUTION - Tank and tank components should be delimed regularly depending on local water conditions. Excessive mineral build-up on stainless steel surfaces can initiate corrosive reactions resulting in serious leaks.

Inspect the tank assembly for excessive lime deposits. Delime as required.

4. Water Pressure

The water pressure to the brewer must be at least 20 psi.

Consistently high or low beverage level in the dispenser

1. Brew Timer

With the ICED/OFF/HOT switch in the "ICED" position adjust the needle valve to achieve the recommended 76 oz of concentrate then the timer to achieve a total of 396 oz for each three-gallon brew cycle.

TROUBLESHOOTING (cont.)

PROBLEM

PROBABLE CAUSE

REMEDY

Consistently high or low beverage level in the dispenser. (cont.)

2. External Strainer/Flow Control (.750 GPM)

(A) Direction of flow arrow must be pointing towards brewer.

(B) Remove the strainer/flow control and check for obstructions. Clear or replace.

Spitting or excessive steaming

1. Lime Build-up
CAUTION - Tank and tank components should be delimed regularly depending on local water conditions. Excessive mineral build-up on stainless steel surfaces can initiate corrosive reactions resulting in serious leaks.

Inspect tank assembly for excessive lime deposits. Delime as required.

2. Control Thermostat

Refer to *Service* - Control Thermostat for testing procedures. See page 23

Drip-out time too long

1. Funnel Tip

The brew funnel should be cleaned thoroughly before each brew cycle to lessen the chance of tea leaf particles clogging the drip-out tip.

Dripping from sprayhead

1. Syphon System

The brewer must be level or slightly lower in front to syphon properly.

2. Lime Build-up
CAUTION - Tank and tank components should be delimed regularly depending on local water conditions. Excessive mineral build-up on stainless steel surfaces can initiate corrosive reactions resulting in serious leaks.

Inspect the tank assembly for excessive lime deposits. Delime as required.

3. Brew Solenoid Valve
A) Iced Tea

Refer to *Service* - Brew Solenoid Valve (Iced Tea) for testing procedures. See page 16

B) Hot Tea

Refer to *Service*- Brew Solenoid Valve (Hot Tea) for testing procedures. See Page 15

TROUBLESHOOTING (cont.)

PROBLEM	PROBABLE CAUSE	REMEDY
Water flows into tank continuously (ICED/OFF/HOT Switch in the "ICED or "HOT" position)	1. Brew Timer A) Iced Tea	Refer to <i>Service</i> - Brew Timer (Iced Tea) for testing procedures. See page 20
	B) Hot Tea	Refer to <i>Service</i> - Brew Timer (Hot Tea) for testing procedures. See page 17
Water flows into tank continuously (ICED/OFF/HOT Switch in the "OFF" position)	1. Brew Solenoid Valve A) Iced Tea	Refer to <i>Service</i> - Brew Solenoid Valve (Iced Tea) for testing procedures. See page 16
	B) Hot Tea	Refer to <i>Service</i> - Brew Solenoid Valve (Hot Tea) for testing procedures. See page 15
Beverage overflows dispenser	1. Dispenser	The dispenser must be completely empty before starting a brew cycle.
	2. Brew Timer A) Iced Tea	Refer to <i>Service</i> - Brew Timer (Iced Tea) for testing procedures. See page 20 or 21
	B) Hot Tea	Refer to <i>Service</i> - Brew Timer (Hot Tea) for testing procedures. See page 17 or 18
	3. Brew Solenoid Valve A) Iced Tea	Remove the Iced Tea Brew Solenoid Valve and clean any obstruction. Rebuild or replace the valve if necessary. See page 16
B) Hot Tea	Remove the Hot Tea Brew Solenoid Valve and clean any obstruction. Rebuild or replace the valve if necessary. See page 15	
	4. Dilution Solenoid Valve	Refer to <i>Service</i> - Dilution Solenoid Valve for testing procedures. See page 24

TROUBLESHOOTING (cont.)

PROBLEM

Weak beverage

PROBABLE CAUSE

1. Filter Type
2. Tea
3. Sprayhead
4. Funnel Loading
5. Water Temperature

REMEDY

BUNN® paper filters must be used for proper extraction.

A sufficient quantity of fresh, loose tea leaves should be used for proper extraction.

A six-hole stainless steel sprayhead must be used for proper extraction.

The BUNN® paper filter must be centered in the funnel and the bed of tea leaves leveled by gentle shaking.

Place an empty funnel on an empty dispenser beneath the sprayhead. Initiate a brew cycle and check the water temperature immediately below the sprayhead with a thermometer. The reading should not be less than 200°F (93°C). Adjust the control thermostat to increase the water temperature. Replace if necessary.

Dry tea leaves remain in the funnel

1. Funnel Loading

The BUNN® paper filter must be centered in the funnel and the bed of grounds leveled by gently shaking.

Brewer is making unusual noises

1. Solenoid(s)
2. Plumbing Lines
3. Water Supply
4. Tank Heater

The nut on the solenoid(s) must be tight or it will vibrate during operation.

Plumbing lines should not be resting on the counter top.

(A) The brewer must be connected to a cold water line.

(B) Water pressure to the brewer must not exceed 90 psi (620 kPa). Install a regulator if necessary to lower the working pressure to approximately 50 psi (345 kPa).

Remove and clean lime off the tank heater. See page 28

SERVICE

This section provides procedures for testing and replacing various major components used in this brewer should service become necessary. Refer to *Troubleshooting* for assistance in determining the cause of any problem.

WARNING - Inspection, testing, and repair of electrical equipment should be performed only by qualified service personnel. The brewer should be disconnected from the power source when servicing, except when electrical tests are required and the test procedure specifically states to plug in the brewer.

COMPONENT ACCESS

WARNING - Disconnect the brewer from the power source before the removal of any panel or the replacement of any component.

All components are accessible by the removal of the top cover and rear inspection panel.

The top cover is attached with four #6-32 screws. Removal of the top cover will allow access to ICED/OFF/HOT switch, start switch, brew timers, control thermostat, limit thermostat, thermal fuse and tank heater.

The rear inspection panel is attached with six #8-32 screws. Removal of the rear panel will allow access to the brew solenoid valves and the dilution solenoid valve .222 GPM flow control and check valve.

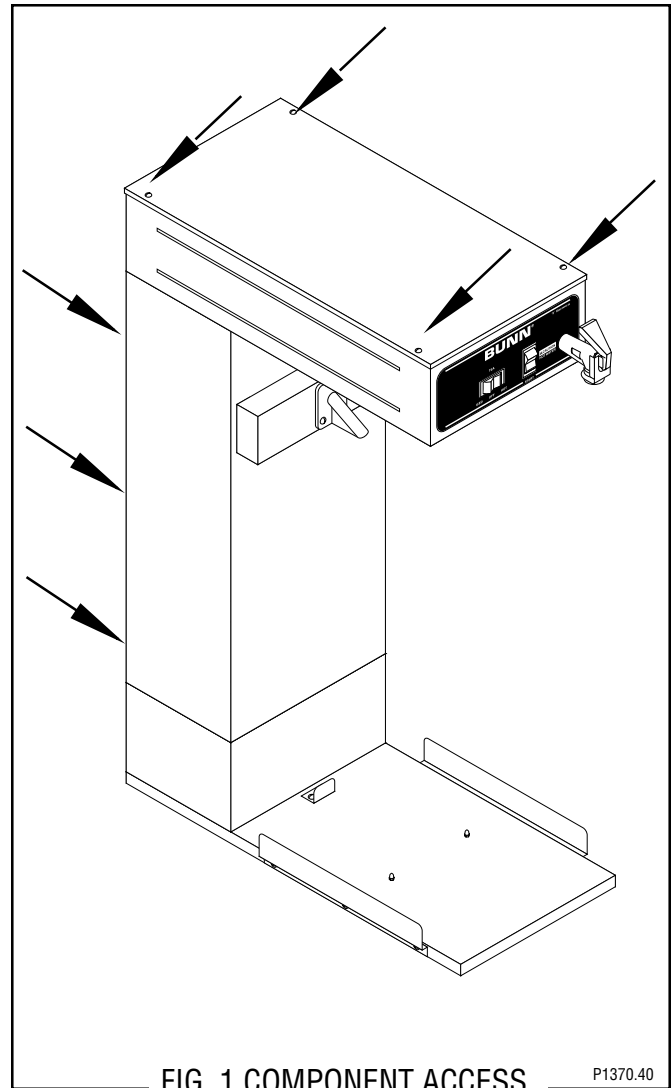

FIG. 1 COMPONENT ACCESS

P1370.40

Contents

Brew Solenoid Valve (Hot Tea)	15
Brew Solenoid Valve (Iced Tea)	16
Brew Timer (Hot Tea) (Early Models)	17
Digital Brew Timer (Hot Tea)(Late Models)	18
Brew Timer (Iced Tea) (Early Models)	20
Digital Brew Timer (Iced Tea)(Late Models)	21
Control Thermostat	23
Dilution Solenoid Valve	24
Limit Thermostat	25
ICED/OFF/HOT Switch	26
Start Switch	27
Tank Heater	28
Thermal Fuse	29
Wiring Diagrams	30

SERVICE (cont.)
BREW SOLENOID VALVE (HOT TEA)

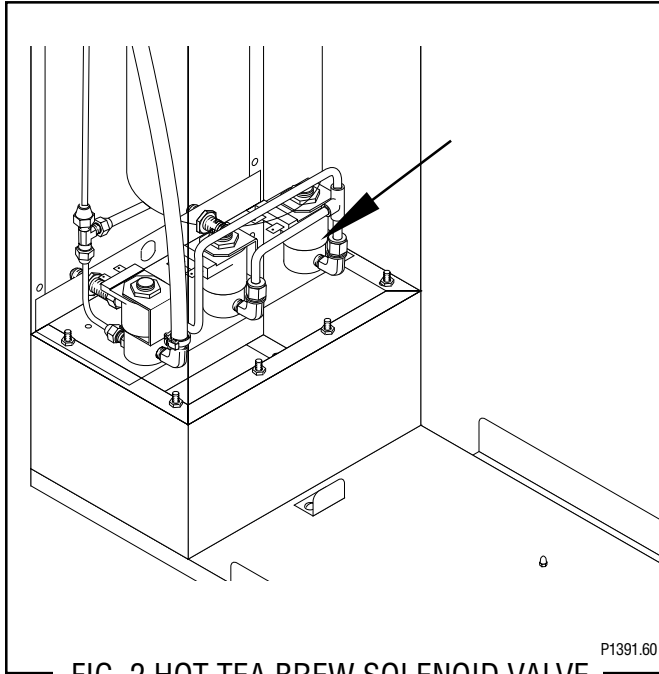

FIG. 2 HOT TEA BREW SOLENOID VALVE

Location:

Viewing the brewer from the rear, the hot tea brew solenoid valve is mounted on the left side of the mounting bracket.

Test Procedures:

1. Disconnect the brewer from the power source.
2. Disconnect the white/red and white/green wires from the hot tea solenoid valve. With the ICED/OFF/HOT switch in the "HOT" position press the start switch.
3. With a voltmeter, check the voltage across the white/red and white/green wires. Connect the brewer to the power source. The indication must be 120 volts ac for two wire 120 volt models and three wire 120/208 volt models.
4. Disconnect the brewer from the power source.

If voltage is present as described, proceed to #5
 If voltage is not present as described, refer to *Wiring Diagram* and check brewer wiring harness.

5. Check for continuity across the hot tea solenoid valve coil terminals.

If continuity is present as described, reconnect the white/red and white/green wires from the hot tea brew timer.

If continuity is not present as described, replace the solenoid valve.

6. Check the hot tea solenoid valve for coil action. Connect the brewer to the power source. With ICED/OFF/HOT switch in the "HOT" position press the start switch and listen carefully in the vicinity of the solenoid valve for a "clicking" sound as the coil magnet attracts.
7. Disconnect the brewer from the power source.

If the sound is heard as described and water will not pass through the solenoid valve, there may be a blockage in the water line before the solenoid valve or, the solenoid valve may require inspection for wear, and removal of waterborne particles.

If the sound is not heard as described, replace the solenoid valve.

Removal and Replacement:

1. Remove all wires from solenoid valves.
2. Turn off the water supply to the brewer.
3. Disconnect the water lines to and from the solenoid valves.
4. Remove the two #8-32 keps nuts holding the mounting bracket to the brewer base.
5. Lift out the bracket.
6. Remove the two #10-32 slotted-head screws holding the hot tea solenoid valve to the mounting bracket.
7. Securely install the new hot tea solenoid valve to the mounting bracket.
8. Attach the mounting bracket to the brewer base.
9. Securely fasten the water lines to and from the solenoid valves.
10. Refer to Fig.3 when reconnecting the wires.

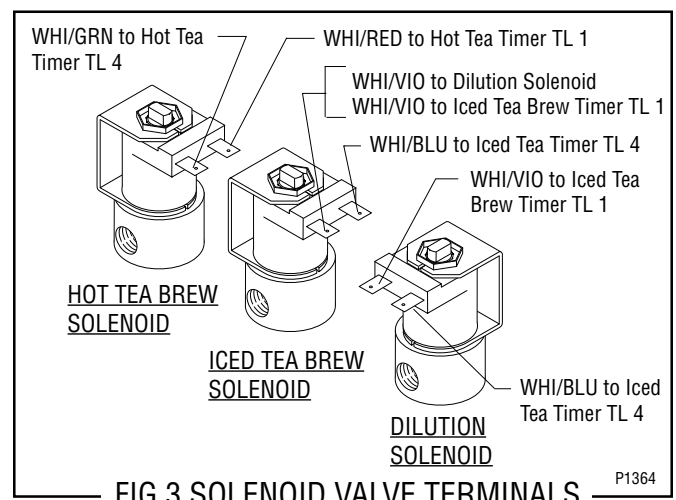

FIG.3 SOLENOID VALVE TERMINALS

SERVICE (cont.)

BREW SOLENOID VALVE (ICED TEA)

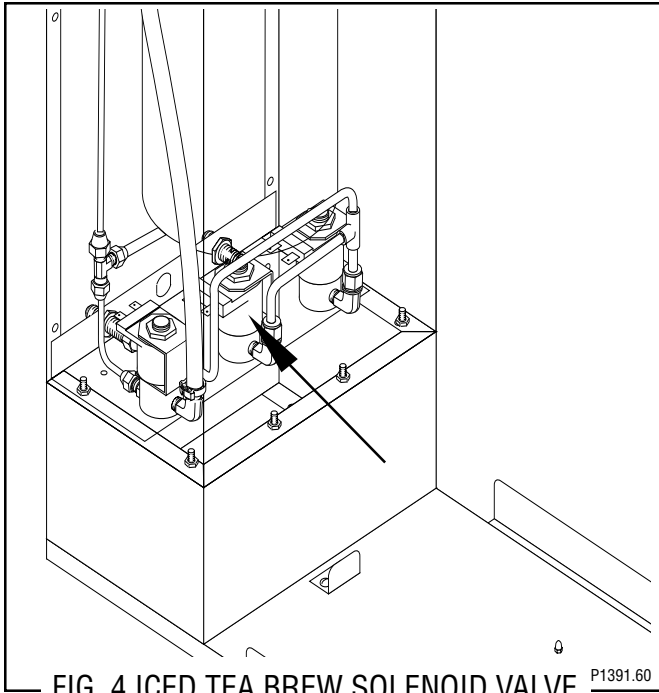

FIG. 4 ICED TEA BREW SOLENOID VALVE P1391.60

Location:

Viewing the brewer from the rear, the iced tea brew solenoid valve is mounted in the center of the mounting bracket.

Test Procedures:

1. Disconnect the brewer from the power source.
2. Disconnect the white/violet and white/blue wires from the iced tea brew solenoid valve. With the ICED/OFF/HOT switch in the "ICED" position press the start switch.
3. With a voltmeter, check the voltage across the white/violet and white/blue wires. Connect the brewer to the power source. The indication must be 120 volts ac for two wire 120 volt models and three wire 120/208 volt models.
4. Disconnect the brewer from the power source.

If voltage is present as described, proceed to #5
If voltage is not present as described, refer to *Wiring Diagram* and check brewer wiring harness.

5. Check for continuity across the iced tea brew solenoid valve coil terminals.

If continuity is present as described, reconnect the white/violet and white/blue wires from the iced tea brew timer.

If continuity is not present as described, replace the solenoid valve.

6. Check the iced tea solenoid valve for coil action. Connect the brewer to the power source. With ICED/OFF/HOT switch in the "ICED" position press the start switch and listen carefully in the vicinity of the solenoid valve for a "clicking" sound as the coil magnet attracts.
7. Disconnect the brewer from the power source.

If the sound is heard as described and water will not pass through the solenoid valve, there may be a blockage in the water line before the solenoid valve, or the solenoid valve may require inspection for wear, and removal of waterborne particles.

If the sound is not heard as described, replace the solenoid valve.

Removal and Replacement:

1. Remove all wires from solenoid valves.
2. Turn off the water supply to the brewer.
3. Disconnect the water lines to and from the solenoid valves.
4. Remove the two #8-32 keps nuts holding the mounting bracket to the brewer base.
5. Lift out the bracket.
6. Remove the two #10-32 slotted-head screws holding the iced tea brew solenoid valve to the mounting bracket.
7. Securely install the new iced tea brew solenoid valve to the mounting bracket.
8. Attach the mounting bracket to the brewer base.
9. Securely fasten the water lines to and from the solenoid valves.
10. Refer to Fig. 5 when reconnecting the wires.

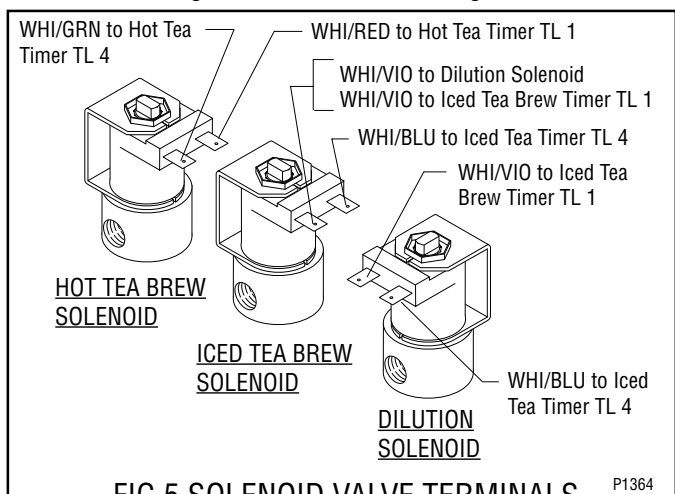
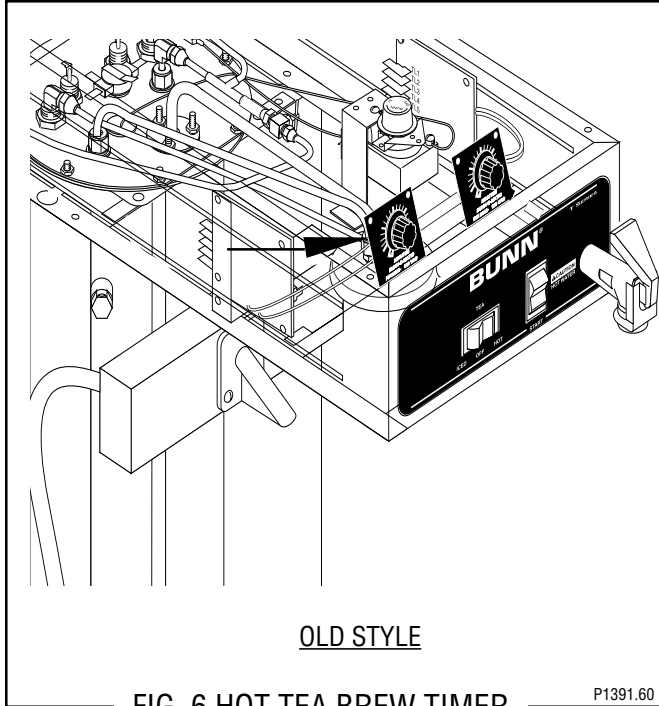

FIG. 5 SOLENOID VALVE TERMINALS P1364

SERVICE (cont.)

BREW TIMER (HOT TEA - EARLY MODELS)



Location.

The hot tea brew timer is located in the hood on the left side. It consists of a dial plate and circuit board.

Test Procedure:

1. Disconnect the brewer from the power source.
2. Remove the wires from terminals TL3, TL4, & TL5 of the timer and rotate the dial fully counterclockwise.
2. With a voltmeter, check the voltage across terminals TL1 and TL2 when the ICED/OFF/HOT switch is in the "HOT" position. Connect the brewer to the power source. The indication must be 120 volts ac for two wire 120 volt models and three wire 120/208 volt models.
3. Disconnect the brewer from the power source.

If voltage is present as described, proceed to #4.

If voltage is not present as described, refer to the *Wiring Diagram* and check the wiring harness.

4. Check for continuity across the white/orange and white/yellow wires when the start switch is held in the lower position.

If continuity is present as described, reconnect the wires to terminals TL3, TL4, & TL5 of the timer board and proceed to #5.

If continuity is not present as described, refer to the *Wiring Diagram* and check the wiring harness.

5. Check the voltage across terminals TL1 and TL4 with a voltmeter when the ICED/OFF/HOT switch is in the "HOT" position and the start switch is momentarily placed in the lower position. Connect the brewer to the power source. The indication must be 120 volts ac for two wire 120 volt models and three wire 120/208 volt models for approximately twenty seconds and then return to its previous indication.
6. Disconnect the brewer from the power source.

If voltage is present as described, the timer is operating properly. Adjust the timer dial as required.

If voltage is not present as described, replace the timer.

Removal and Replacement:

1. Remove all wires from the timer.
2. Remove the circuit board and dial plate from the brackets.
3. Install the new timer circuit board as described in *Late Model Timer* section on the following pages.
4. Refer to Fig.9 when reconnecting the wires.
5. Install the Timer Setting Decal, provided with the timer replacement kit, on the bottom of the hood cover.
6. Adjust the timer as required. See *Late Model Timer Section* on the following pages.

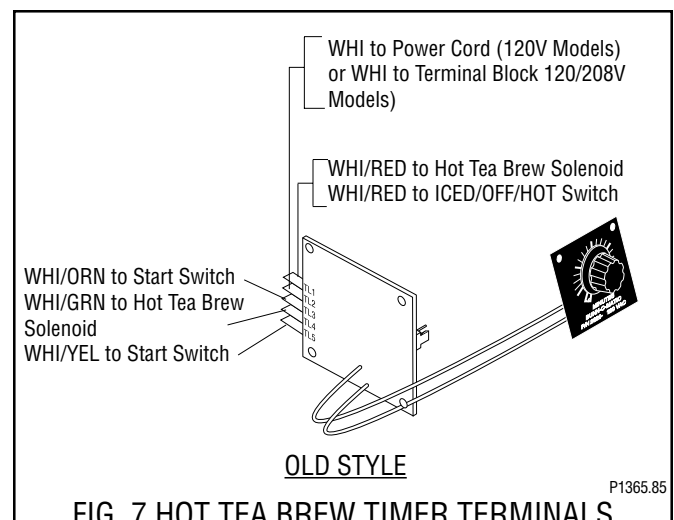

SERVICE (cont.)
BREW TIMER (HOT TEA - LATE MODELS)

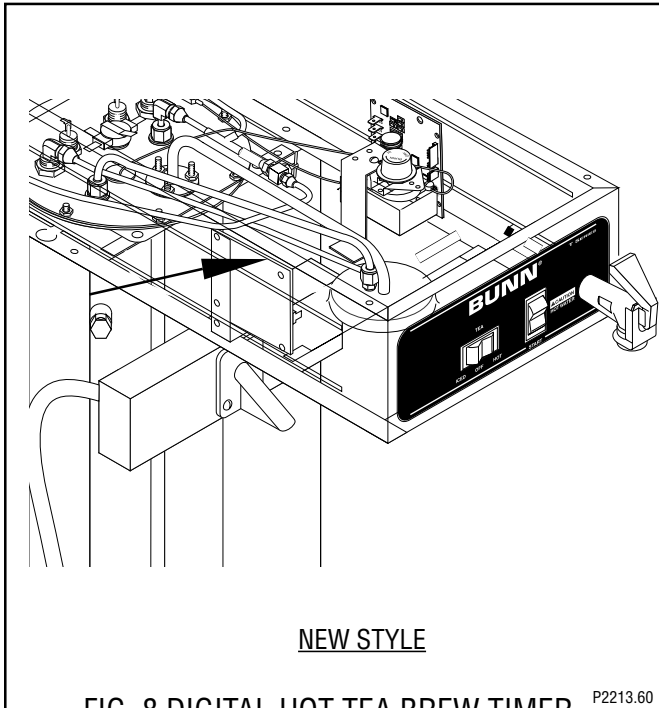

FIG. 8 DIGITAL HOT TEA BREW TIMER

Location:

The hot tea brew timer is located in the hood, on the left side.

Test Procedure.

NOTE: Do not remove or install wires while timer board is installed. Pressure applied to one side may cause damage to the board.

1. Disconnect the brewer from the power source and remove hood cover.
2. Remove the two #8-32 screws securing circuit board to the mounting bracket.
3. Remove circuit board and spacers (as required).
4. With a voltmeter, check the voltage across terminals TL1 and TL2 when the "ON/OFF" switch is in the "ON" position and the ICED/OFF/HOT switch is in the "HOT" position. Connect the brewer to the power source. The indication must be 120 volts ac for two wire 120 volt models and three wire 120/208 volt models.
5. Disconnect the brewer from the power source.

If voltage is present as described, proceed to #6.

If voltage is not present as described, refer to the *Wiring Diagram* and check the brewer wiring harness.

6. With a voltmeter, check the voltage across terminals TL1 and TL4 when the "ON/OFF" switch is in the "ON" position and the ICED/OFF/HOT switch is in the "HOT" position. Connect the brewer to the power source. The indication must be 0 volts.

If voltage is as described, proceed to #7.

If voltage is not as described, disconnect the brewer from the power source and replace the timer.

7. With a voltmeter, check the voltage across terminals TL1 and TL4 when the "ON/OFF" switch is in the "ON" position and the ICED/OFF/HOT switch is in the "HOT" position. Connect the brewer to the power source and press the "START" switch. The indication must be 120 volts ac for two wire 120 volt models and three wire 120/208 volt models.

If voltage is present as described, the brew timer is operating properly. Reset the timer as required, to obtain the desired brew volume.

If voltage is not present as described, disconnect the brewer from the power source and replace the timer.

Removal and Replacement:

1. Remove the two #8-32 screws securing circuit board to the mounting bracket.
2. Remove circuit board and spacers (as required).
3. Remove all wires from the timer.
4. Attach all wires to the replacement timer board prior to installation to the component mounting bracket. Refer to FIG. 9 when reconnecting the wires.
5. Install new circuit board with spacers (as required) to the component mounting bracket.
6. Adjust the timer as described below.

Timer Setting:

NOTE: Prior to setting or modifying volumes, check that the brewer is connected to water supply, the tank is properly filled, and a funnel and server are in place.

NOTE: All volume settings must be done with the sprayhead installed.

SERVICE (cont.)

BREW TIMER (HOT TEA - LATE MODELS)(cont.)

1. **Modifying brew volumes.** To modify a brew volume, first check that the SET/LOCK switch is in the “SET” position on the circuit board.

To increase a brew volume, place the ON/OFF switch in the “ON” position, press and hold the START switch until three clicks are heard. Release the switch and press it again one or more times. (Failure to release the switch within two seconds after the third click causes the volume setting to be aborted and previous volume setting will remain in memory.) Each time the switch is pressed, two seconds are added to the brew time period. Allow the brew cycle to finish in order to verify that the desired volume has been achieved.

To decrease a brew volume, place the ON/OFF switch in the “ON” position, press and release the START switch once for every two-second interval to be removed from the total brew time period; then immediately press and hold down the START switch until three clicks are heard. Release the switch. (Failure to release the switch within two seconds after the third click causes the volume setting to be aborted and previous volume setting will remain in memory). Allow the brew cycle to finish in order to verify that the desired volume has been achieved.

2. **Setting brew volumes.** To set a brew volume, first check that the SET/LOCK switch is in the “SET” position on the circuit board. Place the ON/OFF switch in the “ON” position, press and hold the START switch until three distinct clicks are heard and then release the switch. (Failure to release the switch within two seconds after the third click causes the volume setting to be aborted and previous volume setting will remain in memory.)

View the level of the liquid being dispensed. When the desired level is reached, turn the ON/OFF switch to “OFF”.

NOTE: Several ounces of water will continue to syphon from the tank after turning the switch “OFF”. The brewer remembers this volume and will continue to brew batches of this size until the volume setting

procedure is repeated.

NOTE: When brewing coffee, volume will decrease due to absorption by the coffee grounds.

3. **Setting programming disable feature.** If it becomes necessary to prevent anyone from changing brew time once programmed, you can set the SET/LOCK switch to the “LOCK” position. This will prevent any further programming until switch is once again put into the “SET” position.

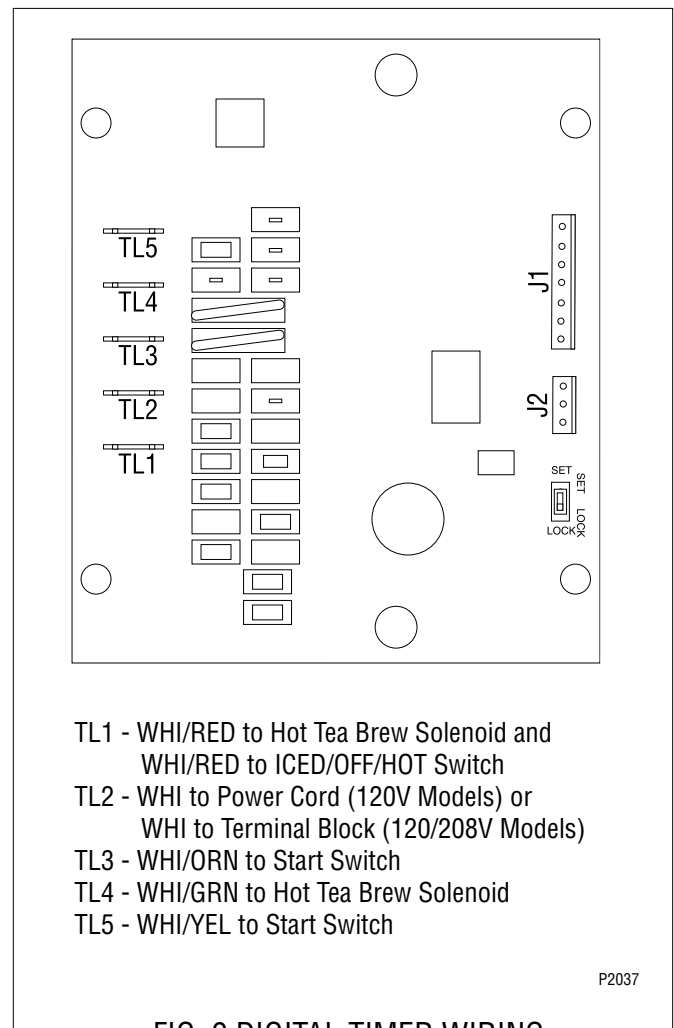

FIG. 9 DIGITAL TIMER WIRING

SERVICE (cont.)

BREW TIMER (ICED TEA - EARLY MODELS)

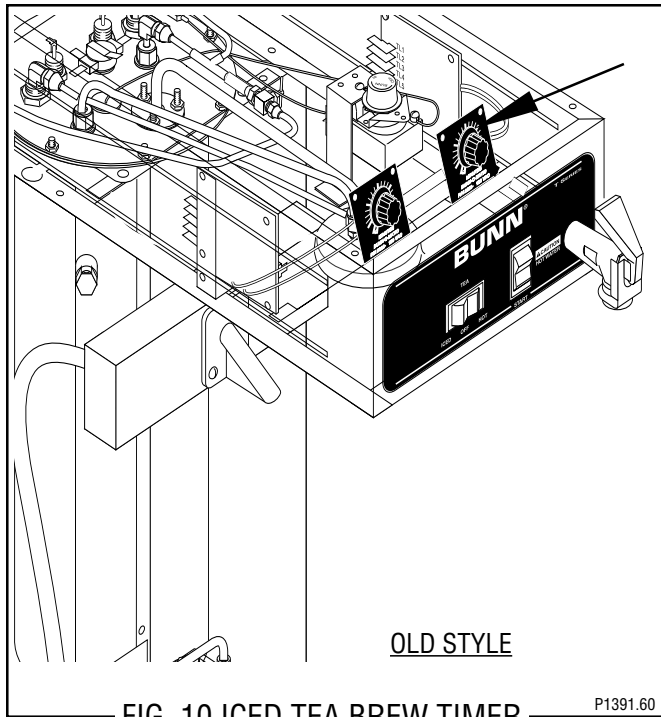

FIG. 10 ICED TEA BREW TIMER

Location:

The iced tea brew timer is located in the hood on the right side. It consists of the dial plate and circuit board.

Test Procedure:

1. Disconnect the brewer from the power source.
2. Remove the wires from terminals TL3, TL4, & TL5 of the iced tea timer and rotate the dial fully counterclockwise.
2. With a voltmeter, check the voltage across terminals TL1 and TL2 when the ICED/OFF/HOT switch is in the "ICED" position. Connect the brewer to the power source. The indication must be 120 volts ac for two wire 120 volt models and three wire 120/208 volt models.
3. Disconnect the brewer from the power source.

If voltage is present as described, proceed to #4.
If voltage is not present as described, refer to the *Wiring Diagram* and check the wiring harness.

4. Check for continuity across the orange and yellow wires when the start switch is held in the lower position.

If continuity is present as described, reconnect the wires to terminals TL3, TL4, & TL5 of the timer board and proceed to #5.

If continuity is not present as described, refer to the *Wiring Diagram* and check the wiring harness.

5. With a voltmeter, check the voltage across terminals TL1 and TL4 when the ICED/OFF/HOT switch is in the "ICED" position and the start switch is momentarily placed in the lower position. Connect the brewer to the power source. The indication must be 120 volts ac for two wire 120 volt models and three wire 120/208 volt models for approximately twenty seconds and then return to its previous indication.
6. Disconnect the brewer from the power source.

If voltage is present as described, the timer is operating properly. Adjust the timer dial as required.

If voltage is not present as described, replace the timer.

Removal and Replacement:

1. Remove all wires from the iced tea brew timer.
2. Remove the circuit board and dial plate from the brackets.
3. Install the new timer circuit board as described in *Late Model Timer* section on the following pages.
4. Refer to Fig. 13 when reconnecting the wires.
5. Install the Timer Setting Decal, provided with the timer replacement kit, on the bottom of the hood cover.
6. Adjust the timer as required. See *Late Model Timer Section* on the following pages.

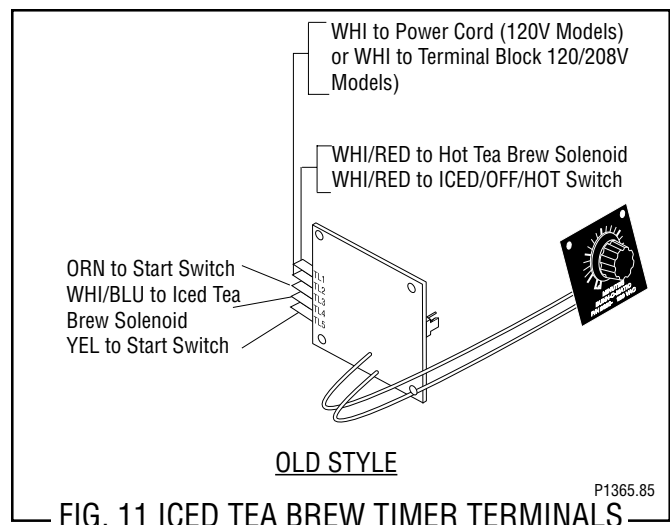

FIG. 11 ICED TEA BREW TIMER TERMINALS

SERVICE (cont.)

BREW TIMER (ICED TEA - LATE MODELS)

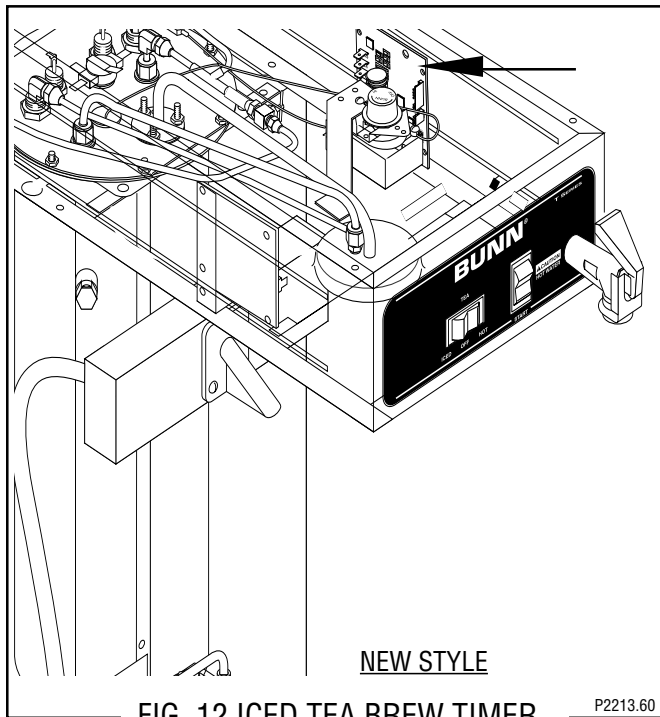

FIG. 12 ICED TEA BREW TIMER

P2213.60

Location:

The timer is located in the hood on the right side.

Test Procedure.

NOTE: Do not remove or install wires while timer board is installed. Pressure applied to one side may cause damage to the board.

1. Disconnect the brewer from the power source and remove the front access panel.
2. Remove the two #8-32 screws securing circuit board to the mounting bracket.
3. Remove circuit board and spacers (as required).
4. With a voltmeter, check the voltage across terminals TL1 and TL2 when the "ON/OFF" switch is in the "ON" position and the ICED/OFF/HOT switch is in the "ICED" position. Connect the brewer to the power source. The indication must be 120 volts ac for two wire 120 volt models and three wire 120/208 volt models.
5. Disconnect the brewer from the power source.

If voltage is present as described, proceed to #6.

If voltage is not present as described, refer to the *Wiring Diagrams* and check the brewer wiring harness.

6. With a voltmeter, check the voltage across terminals TL1 and TL4 when the "ON/OFF" switch is in the "ON" position and the ICED/OFF/HOT switch is in the "ICED" position. Connect the brewer to the power source. The indication must be 0 volts.

If voltage is as described, proceed to #7.

If voltage is not as described, disconnect the brewer from the power source and replace the timer.

7. With a voltmeter, check the voltage across terminals TL1 and TL4 when the "ON/OFF" switch is in the "ON" position and the ICED/OFF/HOT switch is in the "ICED" position. Connect the brewer to the power source and press the "START" switch. The indication must be as follows 120 volts ac for two wire 120 volt models and three wire 120/208 volt models.

If voltage is present as described, the brew timer is operating properly. Reset the timer as required, to obtain the desired brew volume.

If voltage is not present as described, disconnect the brewer from the power source and replace the timer.

Removal and Replacement:

1. Remove the two #8-32 screws securing circuit board to the mounting bracket.
2. Remove circuit board and spacers (as required).
3. Remove all wires from the timer.
4. Attach all wires to the replacement timer board prior to installation to the component mounting bracket. Refer to FIG. 13 when reconnecting the wires.
5. Install new circuit board with spacers (as required) to the component mounting bracket.
6. Adjust the timer as described below.

Timer Setting:

NOTE: Prior to setting or modifying volumes, check that the brewer is connected to water supply, the tank is properly filled, and a funnel and server are in place.

NOTE: All volume settings must be done with the sprayhead installed.

SERVICE (cont.)

BREW TIMER (ICED TEA - LATE MODELS)(cont.)

1. **Modifying brew volumes.** To modify a brew volume, first check that the SET/LOCK switch is in the “SET” position on the circuit board.

To increase a brew volume, place the ON/OFF switch in the “ON” position, press and hold the START switch until three clicks are heard. Release the switch and press it again one or more times. (Failure to release the switch within two seconds after the third click causes the volume setting to be aborted and previous volume setting will remain in memory.) Each time the switch is pressed, two seconds are added to the brew time period. Allow the brew cycle to finish in order to verify that the desired volume has been achieved.

To decrease a brew volume, place the ON/OFF switch in the “ON” position, press and release the START switch once for every two-second interval to be removed from the total brew time period; then immediately press and hold down the START switch until three clicks are heard. Release the switch. (Failure to release the switch within two seconds after the third click causes the volume setting to be aborted and previous volume setting will remain in memory.) Allow the brew cycle to finish in order to verify that the desired volume has been achieved.

2. **Setting brew volumes.** To set a brew volume, first check that the SET/LOCK switch is in the “SET” position on the circuit board. Place the ON/OFF switch in the “ON” position, press and hold the START switch until three distinct clicks are heard and then release the switch. (Failure to release the switch within two seconds after the third click causes the volume setting to be aborted and previous volume setting will remain in memory.)

View the level of the liquid being dispensed. When the desired level is reached, turn the ON/OFF switch to “OFF”.

NOTE: Several ounces of water will continue to siphon from the tank after turning the switch “OFF”. The brewer remembers this volume and will continue to brew batches of this size until the volume setting procedure is repeated.

NOTE: When brewing coffee, volume will decrease due to absorption by the coffee grounds.

3. **Setting programming disable feature.** If it becomes necessary to prevent anyone from changing brew time once programmed, you can set the SET/LOCK switch to the “LOCK” position. This will prevent any further programming until switch is once again put into the “SET” position.

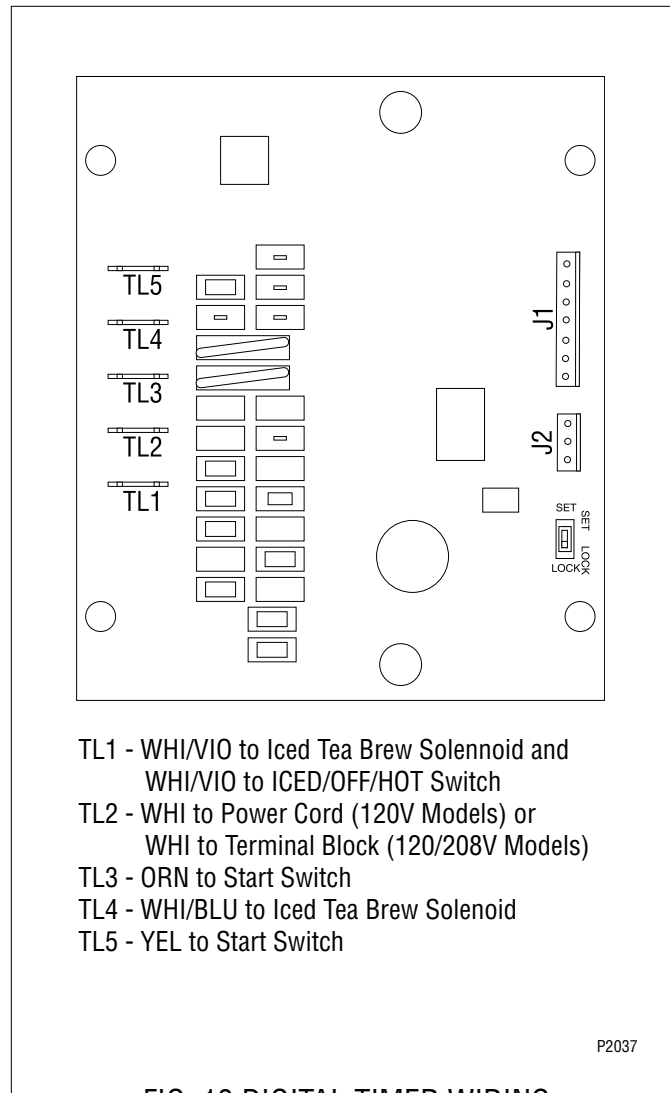

FIG. 13 DIGITAL TIMER WIRING

SERVICE (cont.)

CONTROL THERMOSTAT

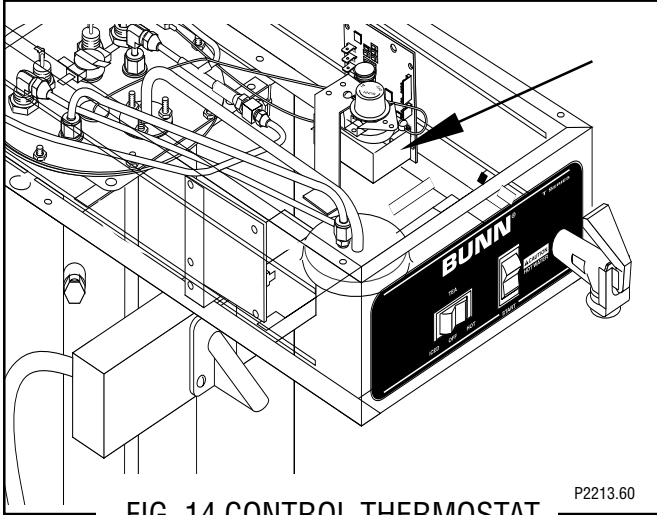

FIG. 14 CONTROL THERMOSTAT

Location:

The control thermostat is located inside hood on the right side just behind the iced tea brew timer.

Test Procedures:

1. Disconnect the brewer from the power source.
2. With a voltmeter, check the voltage across the blue wire on the control thermostat and the white wire on the tank heater for 120 volt two wire models or red wire on the tank heater for 120/208 volt three wire models. Connect the brewer to the power source. The indication must be:
 - a) 120 volts ac for two wire 120 volt models.
 - b) 208 volts ac for three wire 120/208 volt models.
3. Disconnect the brewer from the power source.

If voltage is present as described, proceed to #4.

If voltage is not present as described, refer to the *Wiring Diagram* and check the brewer wiring harness.

4. Locate the black wire on the control thermostat.
5. Gently remove the capillary bulb and grommet from the tank.
6. With a voltmeter, check the voltage across the black wire of the control thermostat and the white wire on the tank heater for 120 volt two wire models or red wire on the tank heater for 120/208 volt three wire models when the control thermostat is turned fully clockwise. Connect the brewer to the power source. The indication must be:
 - a) 120 volts ac for two wire 120 volt models.

b) 208 volts ac for three wire 120/208 volt models

8. Disconnect the brewer from the power source.

If voltage is present as described, reinstall the capillary tube into the tank to the line 4.5" above the bulb, the control thermostat is operating properly.

If voltage is not present as described, replace the thermostat.

Removal and Replacement:

1. Remove both wires from the control thermostat terminals.
 2. Remove the thermostat capillary bulb by firmly pulling up on the capillary tube at the tank lid. This will disengage the grommet from the tank lid.
 3. Remove the #8-32 screw holding the control thermostat to its bracket.
 4. Slide the grommet to the line 4.5" above the bulb on the new capillary tube.
 5. Insert the capillary bulb through the hole in the tank lid and press the grommet firmly and evenly so that the groove in the grommet fits into the tank lid.
 6. Carefully bend the capillary tube so that the tube and bulb inside the tank are in a vertical position.
- NOTE** – The capillary tube must be clear of any electrical termination and not kinked.
7. Fasten the new control thermostat to its bracket.
 8. Refer to Fig. 15 when reconnecting the wires.
 9. Adjust the control thermostat as required.

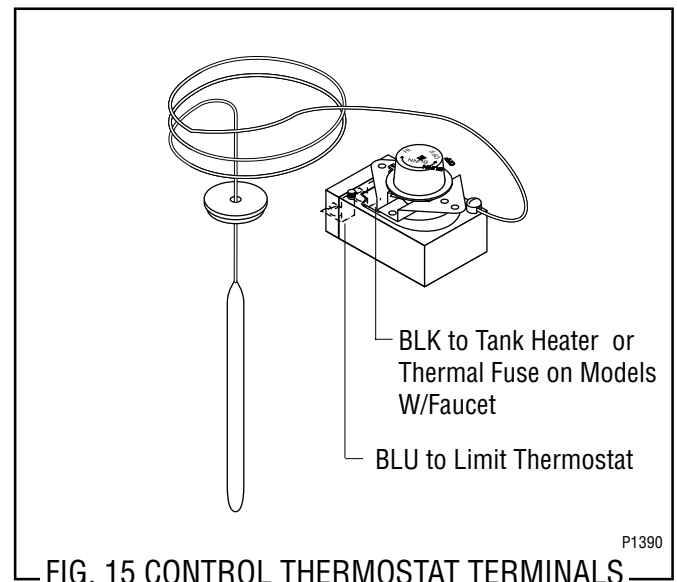
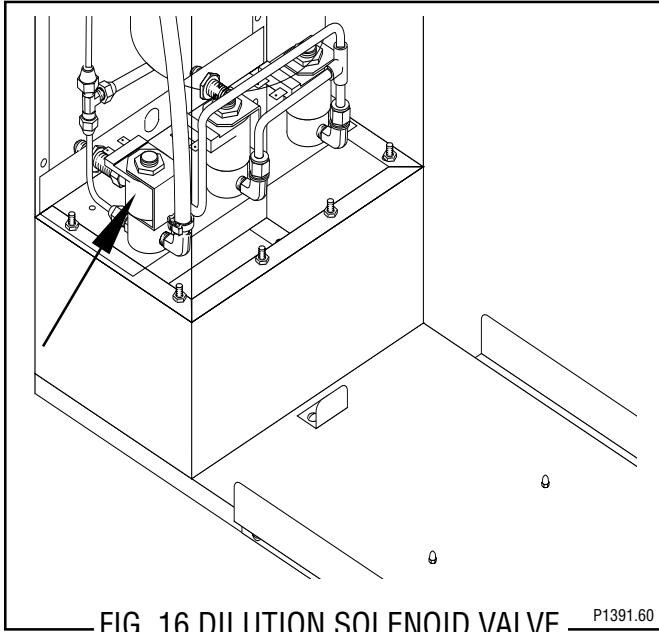

FIG. 15 CONTROL THERMOSTAT TERMINALS

SERVICE (cont.)

DILUTION SOLENOID VALVE



Location:

Viewing the brewer from the rear the dilution solenoid is mounted on the right side of the solenoid mounting bracket which is secured to the trunk base.

Test Procedure:

1. Disconnect the brewer from the power source.
2. With a voltmeter, check the voltage across the white/blue and white/violet wires on the dilution solenoid terminals when the ICED/OFF/HOT switch is in the "ICED" position and the start switch is momentarily placed in the lower position. Connect the brewer to the power source. The indication must be 120 volts ac for two wire 120 volt models and three wire 120/208 volt models.
3. Disconnect the brewer from the power supply.

If voltage is present as described, proceed to #4. If voltage is not present as described, refer to the *Wiring Diagram* and check the wiring harness.

4. Remove both wires from the coil and check for continuity across the coil terminals.

If continuity is present as described, reconnect the white/blue and white/violet wires and proceed to #5. If continuity is not present as described, replace the solenoid valve.

5. Check the solenoid valve for coil action. Connect the brewer to the power source, place the ICED/OFF/HOT switch in the "ICED" position and momentarily place the start switch in the lower position and release. Listen carefully in the vicinity of the solenoid valve for a "clicking" sound as the coil magnet attracts.
6. Disconnect the brewer from the power source.

If the sound is heard as described and water will not pass through the solenoid valve, there may be a blockage in the water line before or after the solenoid valve or, the solenoid valve may require inspection for wear, and removal of waterborne particles. If the sound is not heard as described, replace the solenoid valve.

Removal and Replacement:

1. Remove all wires from the solenoid valves.
2. Turn off the water supply to the brewer.
3. Disconnect the water lines to and from the solenoid valves.
4. Remove the two #8-32 keps nuts holding the mounting bracket to the trunk base.
5. Lift out the bracket.
6. Remove the two #10-32 slotted-head screws holding the solenoid valve to the mounting bracket.
7. Securely install the new solenoid valve to the mounting bracket.
8. Attach the mounting bracket to the trunk base.
9. Securely fasten the water lines to and from the solenoid valves.
10. Refer to Fig. 17 when reconnecting the wires.

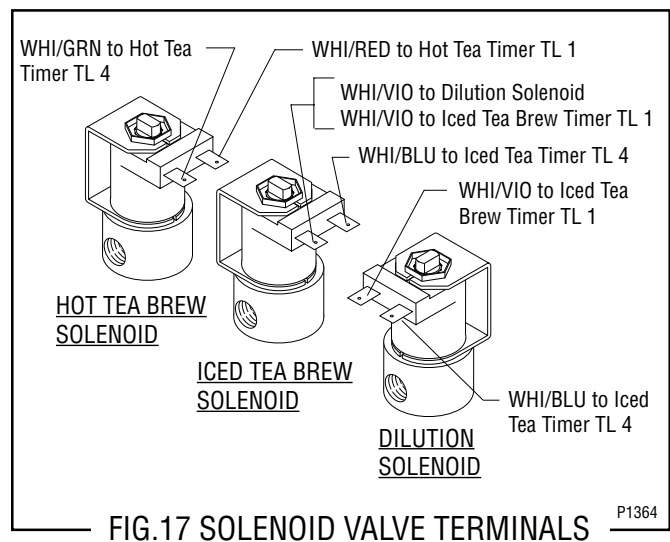

SERVICE (cont.)

LIMIT THERMOSTAT

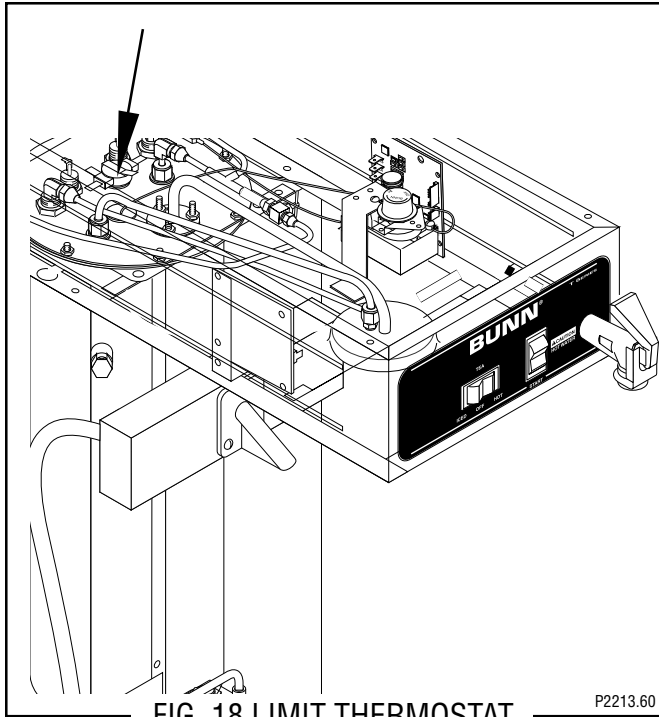

FIG. 18 LIMIT THERMOSTAT

Location:

The limit thermostat is located inside the hood on the tank lid.

Test Procedure:

1. Disconnect the brewer from the power source and remove the black wire from the limit thermostat.
2. With a voltmeter, check the voltage across the black wire removed from the limit thermostat and the white wire or red wire on the tank heater terminal. Connect the brewer to the power source. The indication must be:
 - a) 120 volts ac for two wire 120 volt models.
 - b) 208 volts ac for three wire 120/208 volt models.
3. Disconnect the brewer to from the power source.

If voltage is present as described, reconnect the black wire and proceed to #4.

If voltage is not present as described, refer to the *Wiring Diagram* and check the wiring harness.

4. Remove the blue wire from the limit thermostat.

5. With a voltmeter, check the voltage across the exposed terminal of the limit thermostat and the white wire from the power cord or the red wire from the terminal block. Connect the brewer to the power source. The indication must be:
 - a) 120 volts ac for two wire 120 volt models.
 - b) 208 volts ac for three wire 120/208 volt models.
6. Disconnect the brewer from the power source.

If voltage is present as described, reconnect the blue wire to the limit thermostat. The limit thermostat is operating properly.

If voltage is not present as described, replace the limit thermostat.

Removal and Replacement

1. Remove both wires from the limit thermostat terminals.
2. Carefully slide the limit thermostat out from under the retaining clip.
3. Carefully slide the new limit thermostat into the retaining clip.
4. Refer to Fig. 19 when reconnecting the wires.

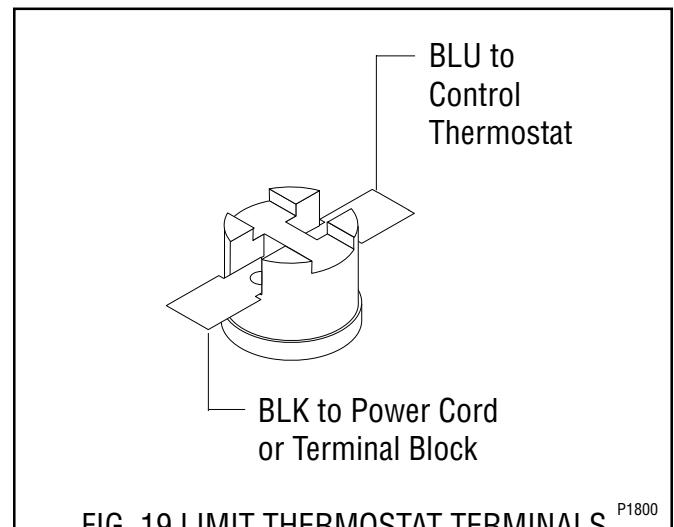

FIG. 19 LIMIT THERMOSTAT TERMINALS

SERVICE (cont.)

ICED/OFF/HOT SWITCH

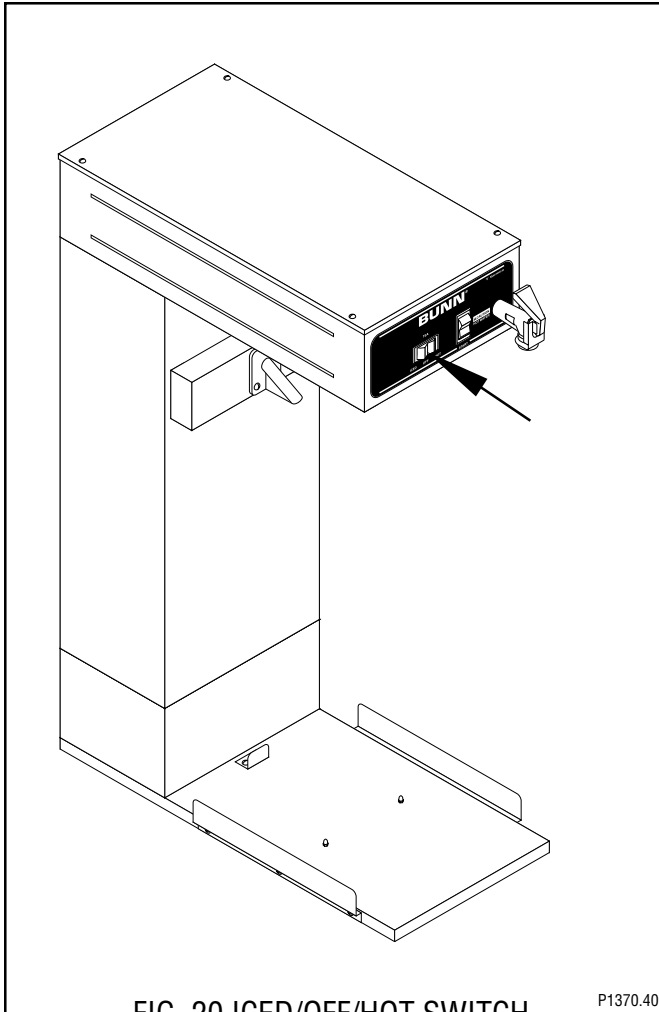

FIG. 20 ICED/OFF/HOT SWITCH

Location:

The ICED/OFF/HOT switch is located in the front of the hood, above and to the left of the brew funnel.

Test Procedure:

1. Disconnect the brewer from the power source.
2. Remove the black and white/violet wires from the switch terminals.
3. With a voltmeter, check the voltage across the black wire removed from the ICED/OFF/HOT switch and the white wire remaining on the switch terminal.
4. Connect the brewer to the power source. The indication must be 120 volts ac for two wire 120 volt models and three wire 120/208 volt models,
5. Disconnect the brewer from the power source.

If voltage is present as described, proceed to #6. If voltage is not present as described, refer to the *Wiring Diagram* and check the wiring harness.

6. Check for continuity across the center and left terminals of the top row when switch is in the "ICED" position and the center and right terminals of the top row when the switch is in the "HOT" position.

If continuity is present as described, replace the wires, the switch is operating properly.

If continuity is not present as described, replace the switch.

Removal and Replacement:

1. Remove the wires from the switch terminals.
2. Compress the clips inside the hood and gently push the switch through the opening.
3. Push the new switch into the opening and spread the clips to hold the switch captive in the hood.
4. Refer to FIG. 21 when reconnecting the wires.

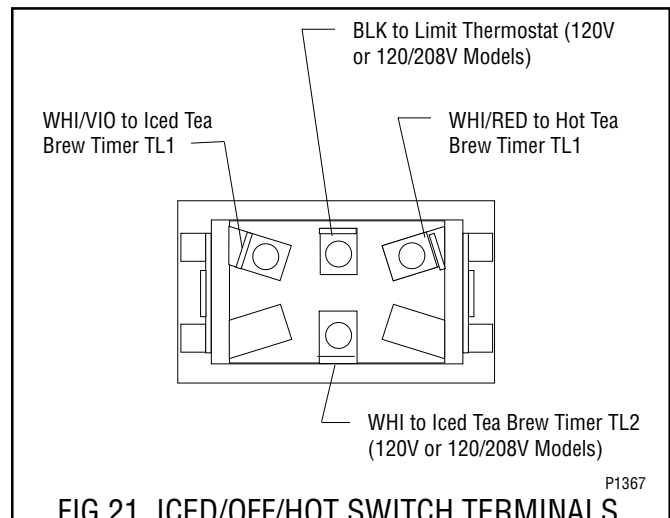

FIG. 21 ICED/OFF/HOT SWITCH TERMINALS

SERVICE (cont.)

START SWITCH

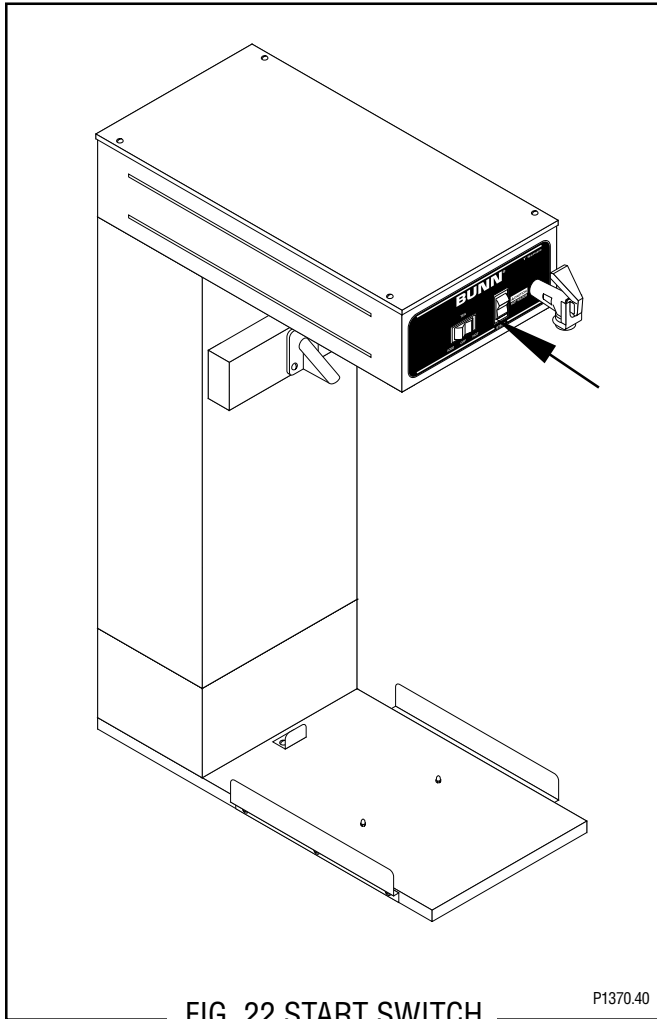

FIG. 22 START SWITCH

Location:

The start switch is located in the front of the hood, above and to the right of the brew funnel.

Test Procedure:

1. Disconnect the brewer from the power source.
2. Remove the wires from all four terminals.
3. Check for continuity across the two terminals on the right side of the switch when it is held in the lower position. Continuity must not be present across these terminals in the upper position.

If continuity is present as described, proceed to #4. If continuity is not present as described, replace the switch.

4. Check for continuity across the two terminals on the left side of the switch when it is held in the lower position. Continuity must not be present across these terminals in the upper position.

If continuity is present as described, reconnect the wires, the switch is operating properly. If continuity is not present as described, replace the switch.

Removal and Replacement:

1. Remove the wires from the switch terminals.
2. Compress the clips inside the hood and gently push the switch through the opening.
3. Push the new switch into the opening and spread the clips to hold the switch captive in the hood.
4. Refer to Fig. 23 when reconnecting the wires.

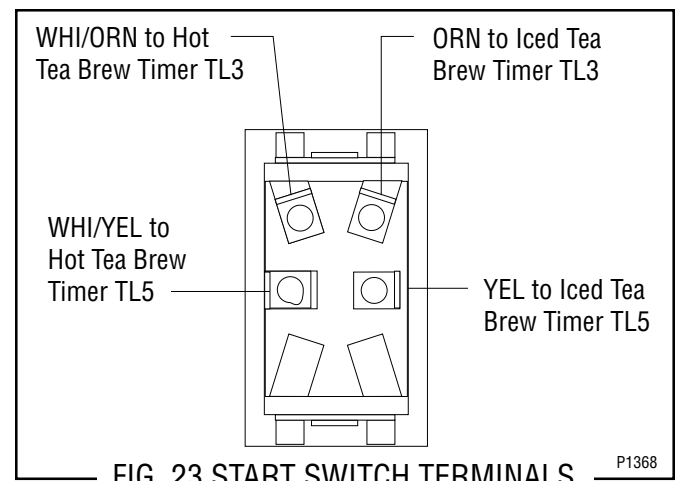
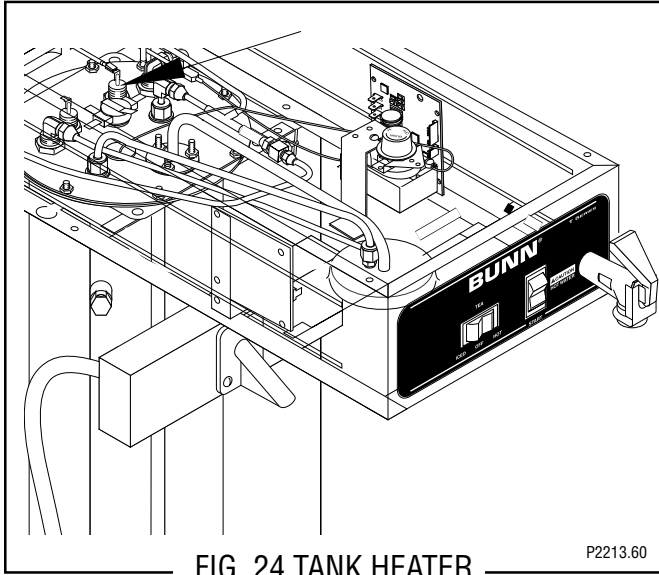

FIG. 23 START SWITCH TERMINALS

SERVICE (cont.)

TANK HEATER



Location:

The tank heater is located inside the tank and secured to the tank lid.

Test Procedures:

1. Disconnect the brewer from the power supply.
2. With a voltmeter, check the voltage across the black and white wires on 120 volt models or the black and red wires for 120/208 volt models with a voltmeter. Connect the brewer to the power source. The indication must be:
 - a) 120 volts ac for two wire 120 volt models .
 - b) 208 volts ac for three wire 120/208 volt models.
3. Disconnect the brewer from the power source.

If voltage is present as described, proceed to #4
If voltage is not present as described, refer to the *Wiring Diagrams* and check wiring harness.

4. Disconnect the black wire and the white wire or red wire from the tank heater terminals.
5. Check for continuity across the tank heater terminals.

If continuity is present as described, reconnect the wires, the tank heater is operating properly.
If continuity is not present as described, replace the tank heater.

NOTE- If the tank heater remains unable to heat, remove and inspect heater for cracks in the sheath.

Removal and Replacement:

1. Disconnect the black wire and the white or red wire from the tank heater terminals.
2. Remove sprayhead and the hex nut securing the sprayhead tube to the hood. Set aside for reassembly.
3. Disconnect vent tube.
4. Remove the six #10 thread cutting screws securing the tank lid to the tank.
5. Remove the tank lid with limit thermostat, sprayhead tube, tank heater and vent tube.
6. Remove the two hex nuts securing the tank heater to the tank lid. Remove tank heater with gaskets and discard.
7. Install new tank heater with gaskets on the tank lid and secure with two hex nuts.
8. Install tank lid with limit thermostat, sprayhead tube, tank heater and vent tube using six #10 thread cutting screws.
9. Secure sprayhead tube to hood using a hex nut.
10. Install sprayhead.
11. Connect vent tube to fitting.
12. Reconnect the wires to the limit thermostat and tank heater. See limit thermostat section in this manual when reconnecting wires.
13. Refer to Fig.25 when reconnecting the tank heater wires.

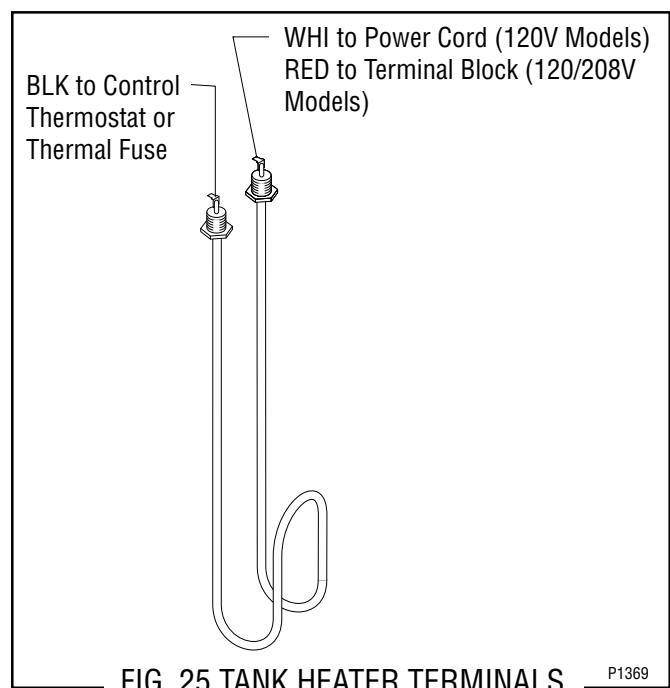

SERVICE (cont.)

THERMAL FUSE (Models W/Faucet Only)

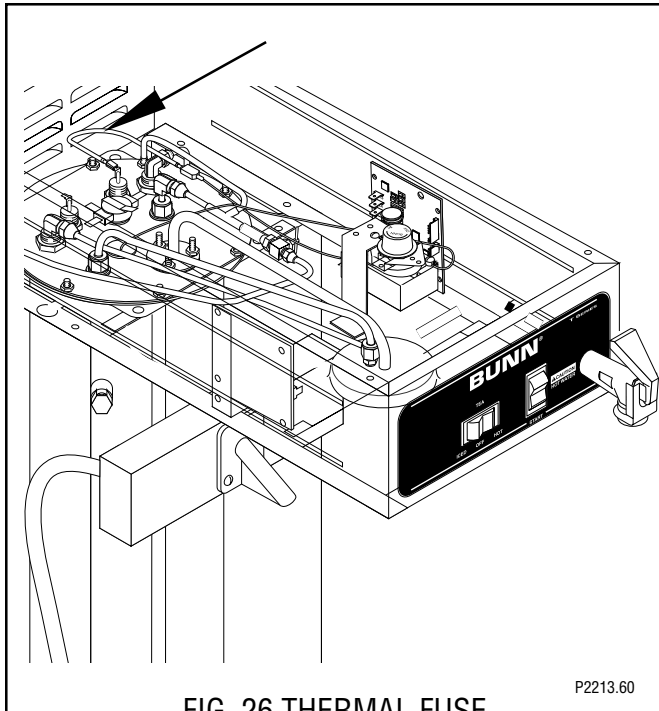

FIG. 26 THERMAL FUSE

Location:

The thermal fuse is located inside the hood connected to the right tank heater terminal.

Test Procedures:

1. Disconnect the brewer from the power source.
2. Disconnect the thermal fuse from the right tank heater terminal and the black lead from the control thermostat.
3. With an ohmmeter, check for continuity across the thermal fuse terminals.

If continuity is present as described, the thermal fuse is operating properly.

If continuity is not present as described, replace the thermal fuse.

Removal and Replacement:

1. Disconnect the thermal fuse from the right tank heater terminal and the black lead from the control thermostat.
2. Remove thermal fuse and discard.
3. Connect new thermal fuse to the right tank heater terminal and the black lead from the control thermostat.
4. Refer to Fig. 27 when reconnecting wires.

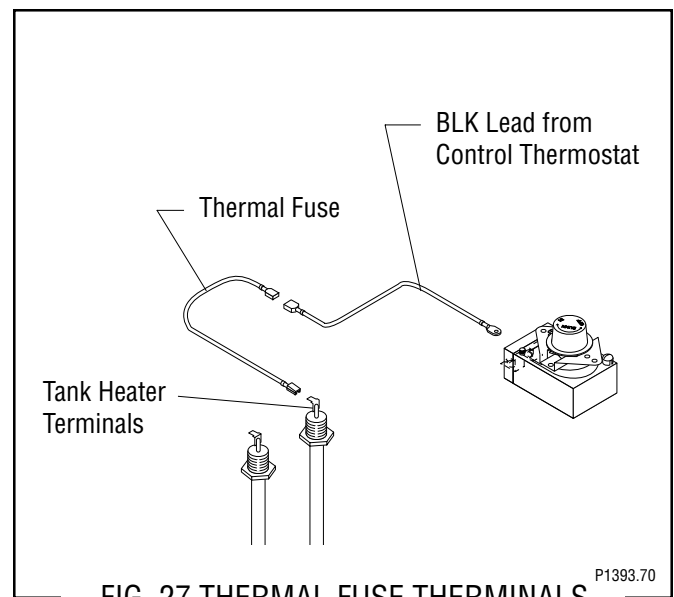
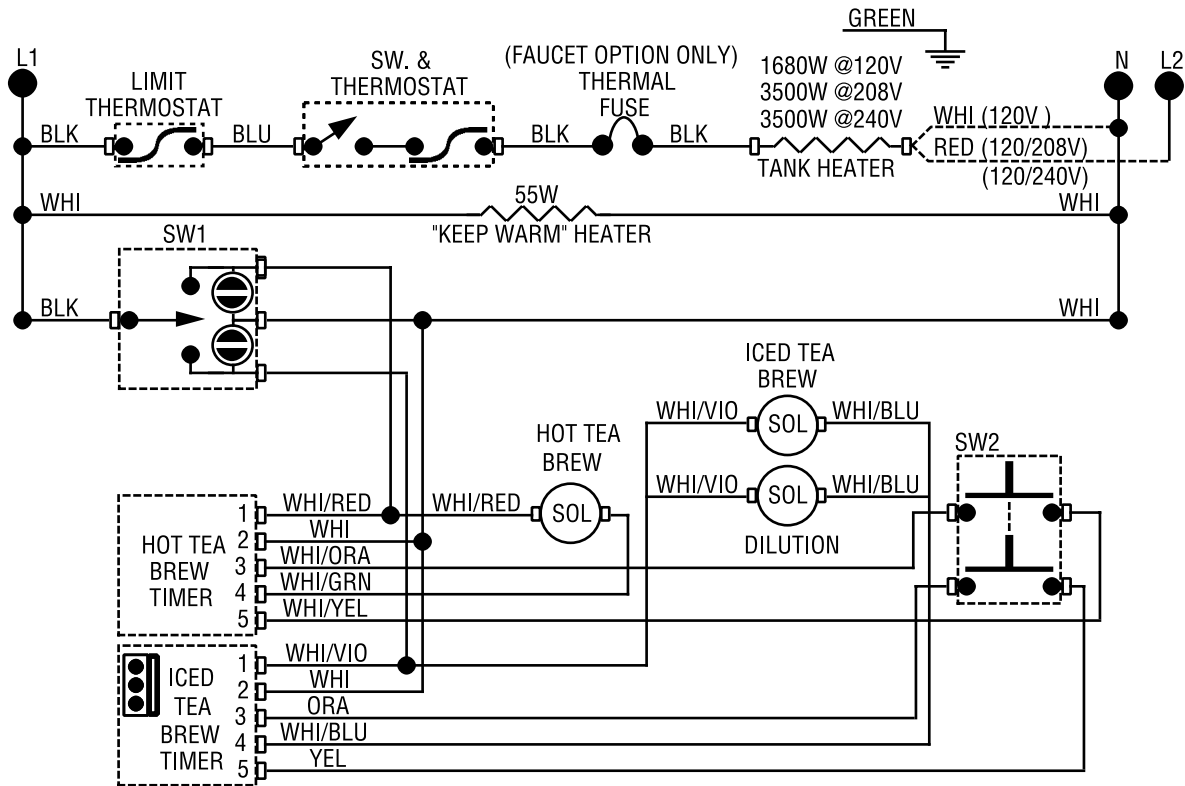

FIG. 27 THERMAL FUSE THERMINALS

SCHEMATIC WIRING DIAGRAM TNT & TNTF



120 VOLTS AC 2 WIRE
120/208VOLTS AC 3 WIRE
120/240VOLTS AC 3 WIRE
SINGLE PHASE