

# BUNN®

ThermoFresh®  
1/2 & 1 3/4 Gallon Server

---

## USE & CARE INSTRUCTIONS

---

### INTRODUCTION

These servers allow portable storage and dispensing of 1/2 or up to 1 3/4 gallons of hot beverage at remote locations. Coffee can be brewed directly into the server without removing the cover when used with a BUNN® Dual®-TF or Single®-TF coffee brewer. A brew batch sensor prohibits brewing 1/2 gallon when the 1 3/4 gallon server is in place on the brewer or vice versa. The spill-resistant design lessens the chance of hot beverage burns and splashes. An easy to use indicator on the front of the server shows when decaffeinated coffee is being used.

### WARRANTY

Bunn-O-Matic Corp. ("Bunn") warrants the equipment manufactured by it to be commercially free from defects in material and workmanship existing at the time of manufacture and appearing within one year from the date of installation. In addition:

1.) Bunn warrants electronic circuit and/or control boards to be commercially free from defects in material and workmanship for two years from the date of installation.

2.) Bunn warrants the compressor on refrigeration equipment to be commercially free from defects in material and workmanship for two years from the date of installation.

3.) Bunn warrants that the grinding burrs on coffee grinding equipment will grind coffee to meet original factory screen sieve analysis for three years from date of installation or for 30,000 pounds of coffee, whichever comes first.

This warranty does not apply to any equipment, component or part that was not manufactured by Bunn or that, in Bunn's judgement, has been affected by misuse, neglect, alteration, improper installation or operation, improper maintenance or repair, damage or casualty.

THE FOREGOING WARRANTY IS EXCLUSIVE AND IS IN LIEU OF ANY OTHER WARRANTY, WRITTEN OR ORAL, EXPRESS OR IMPLIED, INCLUDING, BUT NOT LIMITED TO, ANY IMPLIED WARRANTY OF EITHER MERCHANTABILITY OR FITNESS FOR A PARTICULAR PURPOSE. The agents, dealers or employees of Bunn are not authorized to make modifications to this warranty or to make additional warranties that are binding on Bunn. Accordingly, statements by such individuals, whether oral or written, do not constitute warranties and should not be relied upon.

The Buyer shall give Bunn prompt notice of any claim to be made under this warranty by telephone at (217) 529-6601 or by writing to Post Office Box 3227, Springfield, Illinois, 62708-3227. If requested by Bunn, the Buyer shall ship the defective equipment prepaid to an authorized Bunn service location. If Bunn determines, in its sole discretion, that the equipment does not conform to the warranty, Bunn shall repair the equipment with no charge for parts during the warranty period and no charge for labor by a Bunn Authorized Service Representative during the warranty period. If Bunn determines that repair is not feasible, Bunn shall, at its sole option, replace the equipment or refund the purchase price for the equipment.

THE BUYER'S REMEDY AGAINST BUNN FOR THE BREACH OF ANY OBLIGATION ARISING OUT OF THE SALE OF THIS EQUIPMENT, WHETHER DERIVED FROM WARRANTY OR OTHERWISE, SHALL BE LIMITED, AS SPECIFIED HEREIN, TO REPAIR OR, AT BUNN'S SOLE OPTION, REPLACEMENT OR REFUND.

In no event shall Bunn be liable for any other damage or loss, including, but not limited to, lost profits, lost sales, loss of use of equipment, claims of Buyer's customers, cost of capital, cost of down time, cost of substitute equipment, facilities or services, or any other special, incidental or consequential damages.

**BUNN-O-MATIC CORPORATION**

**POST OFFICE BOX 3227, SPRINGFIELD, ILLINOIS 62708-3227**

**TELEPHONE: (217) 529-6601    FAX: (217) 529-6644**

## USING THE SERVER

Simply select the desired brew batch size with the rotary switch on the brewer and place the corresponding server beneath the funnel dripout. One or one and three-quarter gallon batches may be brewed into the 1¾ gallon server. Press and release the start switch to initiate a brew cycle. Place the decaffeinated coffee indicator in the proper position for the type of coffee used before brewing. Fresh HOT coffee is immediately available at the faucet.

**NOTE** – Be careful that the server can hold the entire brew batch selected before initiating a brew cycle.

## USER NOTICES

The notices on this server should be kept in good condition. Replace unreadable or damaged labels.

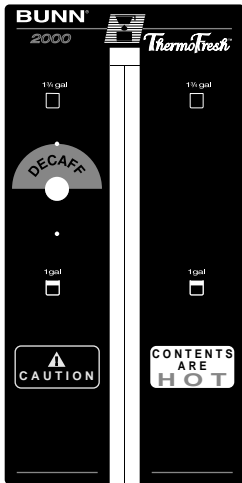

#26178.0001  
(1¾ gallon server)



#26186.0000

#26178.0002  
(½ gallon server)



## CLEANING

1. Turn the entire lid assembly one-quarter turn counterclockwise to remove it for daily dishwasher cleaning. Bunn-O-Matic recommends CASCADE® dishwashing detergent for thorough cleaning. **DO NOT** use bleach. CASCADE® is a registered trademark of Procter & Gamble Co., Cincinnati, Ohio.

2. Remove the ball retainer cap A from the top of the lid, the inlet tube assy D from the bottom of the lid, and balls B & C for cleaning. (See illustration at left.) They are removed by unscrewing in a counterclockwise direction.

**NOTE** – Be Careful not to lose the balls. They are necessary for the lid to function properly.

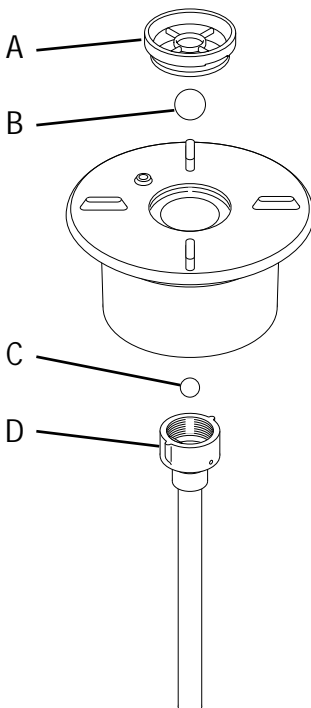

3. Using the supplied brush #26367.0000, clean the airvent E on the bottom of the lid assembly. (See illustration at right.)

4. After cleaning, reassemble the lid assembly, being careful to reinstall all parts removed.

5. Disassemble the faucet for thorough cleaning. Using the supplied #00674.0000 brush, clean the faucet shank. After cleaning, reassemble and reinstall the faucet.

6. Clean the sight gage with the supplied #00675.0000 brush.

7. Clean all other surfaces of the server with a damp cloth rinsed in any mild, non-abrasive, liquid detergent.

8. Thoroughly rinse the entire server after cleaning.

9. Fill with brew temperature water and leave full overnight. **NOTE-** Empty the water from the server before brewing.

