



# MODELS CMA-180 VL-FL PARTS MANUAL Rev 2.00B



**CMA DISHMACHINES  
12700 KNOTT AVENUE  
GARDEN GROVE, CALIFORNIA 92841**

**800-854-6417**

**FAX 714-895-2141**

[www.cmadishmachines.com](http://www.cmadishmachines.com)

[Buy Parts](#)

# TABLE OF CONTENTS

## MODEL CMA-180 VL-FL

<b>1. PARTS MANUAL .....</b>	<b>3</b>
1.1. INITIAL PARTS KIT #1100.16 .....	3
1.2. EXPLODED VIEW DRAWINGS.....	4
1.2.1. Straight Frame System Assembly.....	4
1.2.2. Heat Recovery System.....	5
1.2.3. Drain System Assembly (Ventless Unit).....	6
1.2.4. Plumbing System Assembly.....	7
1.2.5. Wash Spray System.....	8
1.2.6. Final Rinse System Assembly.....	9
1.2.7. Door Assembly.....	10
1.2.8. Pump System Assembly.....	11
1.2.9. Wash Tank Heater (Triangular Flange).....	12
1.2.10. Booster Tank Heater (Triangular Flange) .....	13
1.2.11. Control Box Assembly.....	14
1.2.12. Heat Recovery System Control Box.....	15
1.2.13. Door Safety Interlock (DSI) Assembly.....	16

## 1. Parts Manual

### 1.1. Initial Parts Kit #1100.16

P/N	DESCRIPTION	Qty
00121.17	^CMA-180 Drain Stopper	1
00200.10	Pump Assy. 115/220V 60Hz (Open)	1
00206.30	Pump Seal Kit	1
00304.29	^Rinse Arm w/ Bearings (180.180UC)	1
00307.20	^Spray Arm Assy CMA180 w/bearing&plug	1
00363.00	^Spray Base Pull Lock Pin	1
00404.85	Contactora 208/240V 20 Amp DP	1
00409.94	CMA-180VL-FL Timer Assy	
00411.00	Micro Switch	1
00421.78	Illuminated Plug CMA-180/44 P	1
00421.89	Rocker Switch Auto Fill	
00421.90	Power Switch Red 250V	1
00475.70	Toggle Switch DPDT 15 Amp/Delimer	1
00562.00	Roller Door Switch	1
00602.20	Door Spring	1
00631.05	Ice Cube Relay 220V 12 Amp	1
00706.00	3/4 Water Solenoid Repair Kit JE	1
00707.00	1/2 Water Solenoid Repair Kit JE	
00735.00	3/4 Vac Breaker Rep Kit Watts	1
00738.15	Solenoid Coil JE 220V (3/4 & 1/2)	1
03202.00	Thermometer (Capillary)	1
03408.55	Counter - Face Mount 220V/50Hz	1
03470.00	Toggle Switch (Momentary) Screw Term	1
03623.00	1/2 Vac Breaker Repair Kit Watts	1
13003.17	Contactora 60 Amp 3 Pole	1
13003.55	Contactora 30 Amp	1
13304.55	^SS Final Rinse Spray Jet SS	1
13417.92	Heater Thermostat	1
13422.71	^Immersion Heater 240V/12kW T-Flange	1
13463.14	^Liquid Level Switch-Long-D Flat	1
13605.00	Pressure Gauge	1
15518.00	Immersion Heater 6kW208-240V T-Flange	1
17523.51	Hi Limit Switch 250 Deg	1

## 1.2. Exploded View Drawings

### 1.2.1. Straight Frame System Assembly

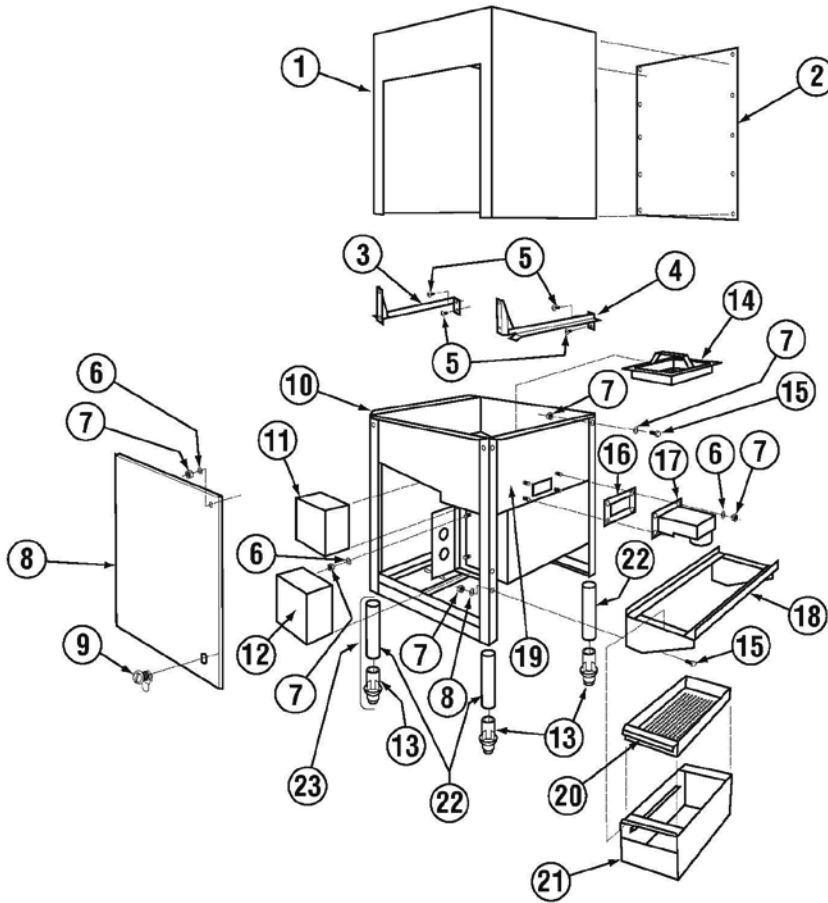

ITEM NO.	NO. REQ'D	P/N	DESCRIPTION
1	1	17670.00	Cma-180VI-FI Wrapper
2	1	17671.00	Cma-180VI-FI Wrapper Panel
3	1	17673.00	Cma-180VI-FI L.H. Tray Track
4	1	17672.00	Cma-180VI-FI R.H. Tray Track
5	4	00914.00	1/4-20 x 3/4 Hexhead Bolt
6	60	00924.00	1/4" SS Washer
7	30	00912.00	1/4"-20 Nylon Lock Nut
8	1	17546.00	CMA-180VL Skirt
9	1	00449.50	Keyless Lock
10	1	17532.18	Frame Stand
11	1	17522.00	Booster Heater Cover
12	1	17522.50	Wash Tank Heater Cover

ITEM NO.	NO. REQ'D	P/N	DESCRIPTION
13	4	01310.00	Bullet Feet
14	2	17510.00	Strainer Basket
15	23	00914.10	1/4-20 X 5/8 Hex Bolt
16	1	17402.00	Overflow Gasket
17	1	17511.00	Overflow
18	1	17579.00	Scrap Trap Holder
19	1	17531.17	Pan
20	1	01579.20	Scrap Trap Drawer
21	1	01579.10	Scrap Body SS
22	4	01572.10	SS Leg (A, AH, C, B)
23	1	01145.00	Leg Assembly, 10" w/Bullet Foot

## 1.2.2. Heat Recovery System

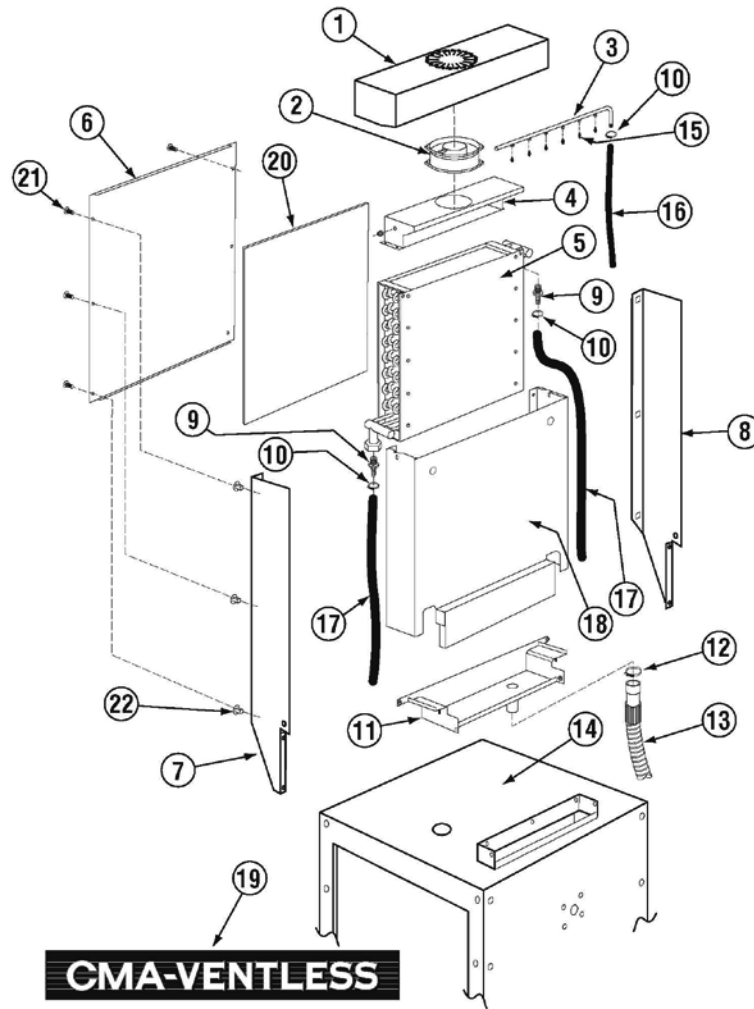

ITEM NO.	NO. REQ'D	P/N	DESCRIPTION
1	1	17595.00	CMA-180 Ventless Top Cover
2	1	02401.01	Motor Fan 230V, 50/60Hz
3	1	02401.17	Battery Self Cleaning Pipe
4	1	17593.00	CMA-180 Ventless Fan Mount
5	1	02401.05	Heat Recovery Battery
6	1	17596.00	CMA-180 Ventless Rear Cover
7	1	17598.00	CMA-180 Ventless Support L.H.
8	1	17597.00	CMA-180 Ventless Support R.H.
9	2	40014.00	1/2m x 1/2 Barb Straight
10	3	03101.45	Hose Clamp #4
11	1	17592.00	CMA-180 Ventless Drain Pan

ITEM NO.	NO. REQ'D	P/N	DESCRIPTION
12	1	03101.00	Hose Clamp #16 1"
13	1	15605.00	Drain Hose with Goose Neck (9-06)
14	1	17591.00	CMA-180 Ventless Wrapper
15	7	02101.01	UC 50e Stainless Steel Rinse Nozzle
16	1	03107.51	Flexible Black Hose 3/8"
17	2	03107.50	Flexible Black Hose 1/2"
18	1	17594.00	CMA-180 Ventless Shroud
19	1	06231.15	CMA Ventless Label 23.25 x 3.25
20	1	17599.15	Heat Recovery Battery Insulation
21	6	00982.00	Phil Truss Screws
22	6	00981.00	Nylon Pop-in Nut

### 1.2.3. Drain System Assembly (Ventless Unit)

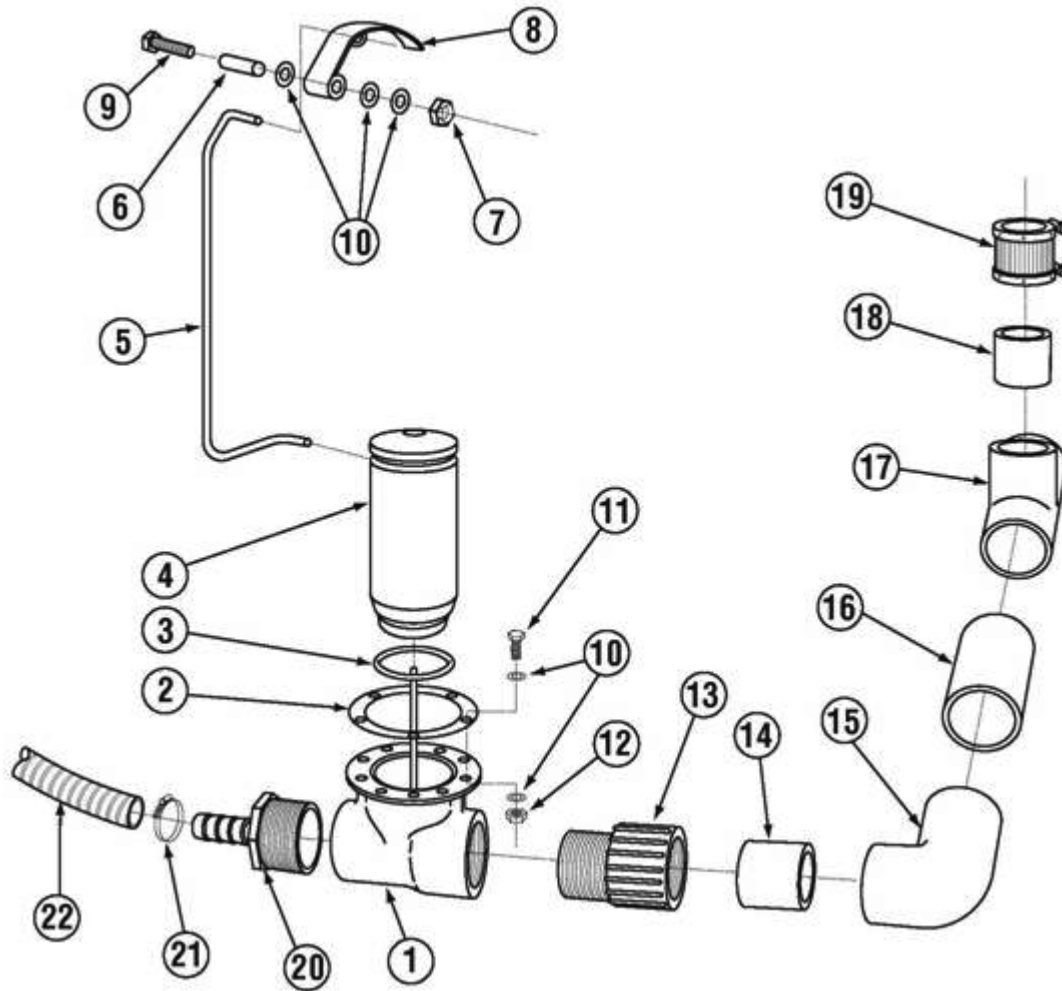

ITEM NO.	NO. REQ'D	P/N	DESCRIPTION
1	1	00113.17	Drain Tee Casting
2	1	00114.00	Drain Tee Gasket
3	1	00121.18	Drain Stopper "O" Ring
*4	1	00121.17	Drain Stopper
5	1	17581.00	Drain Linkage
6	1	17580.50	Drain Linkage Spacer
7	1	00912.00	1/4-20 Nylon Lock Nut
8	1	17580.00	Drain Lever
9	1	00910.00	1/4"-20 x 1 1/2" Hex Head Bolt
10	16	00926.00	5/16 S/S Washer
11	6	00901.00	5/16 -18 x 1" Hex Head Bolt
* #00121.17 includes #00121.18			

ITEM NO.	NO. REQ'D	P/N	DESCRIPTION
12	6	13805.00	5/16-18 Nylon Lock Nut
13	1	01313.00	2" PVC Slip x MIPT Adapter
14	1	05030.17	2" x 4" PVC Tubing
15	1	01312.00	PVC Slip x Slip 90 Ell
16	1	05030.27	2" x 6" PVC Tubing
17	1	01320.17	2" PVC Tee SxSxS
18	1	05030.10	2" x 3" PVC Tubing
19	1	01315.17	2" No Hub
20	1	50302.42	180VL Drain Hose Fitting
21	1	03101.00	Hose Clamp #16 1"
22	1	15605.00	Drain Hose with Goose Neck

### 1.2.4. Plumbing System Assembly

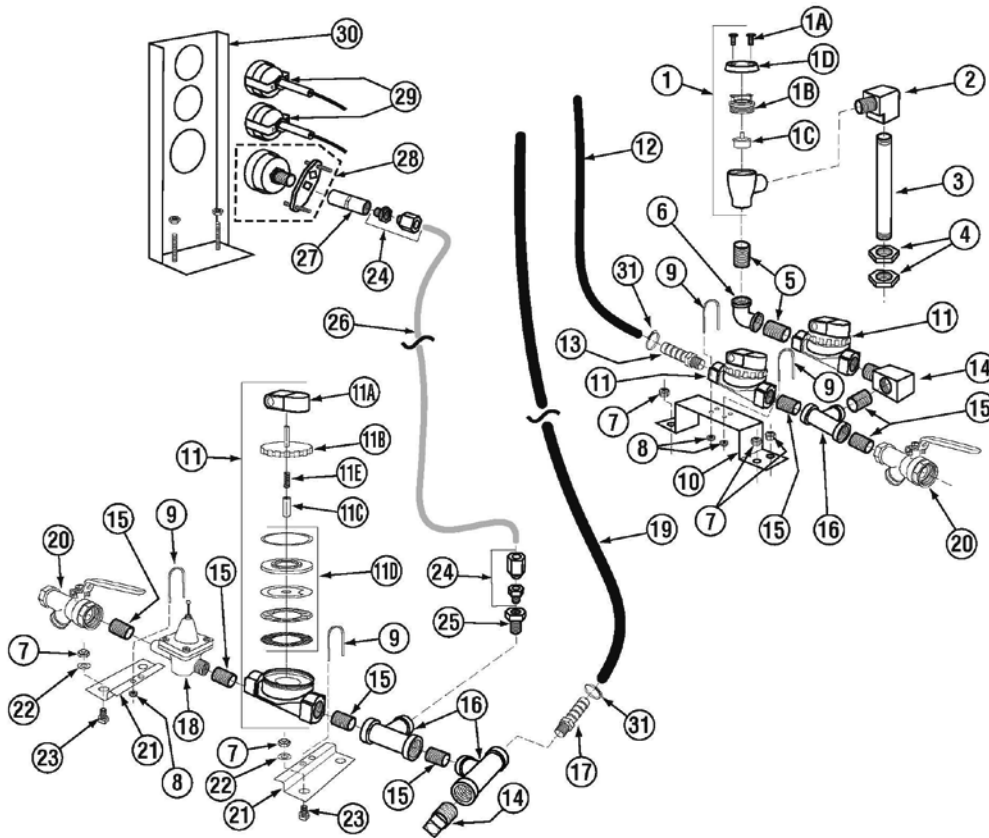

ITEM NO.	NO. REQ'D	P/N	DESCRIPTION
1	1	00710.50	Vacuum Breaker 3/4" Watts
1A	--	00421.51	Pan Head Screw SS 6-32 x 1/4"
1B	--	00735.60	Vacuum Breaker Brass Bonnet 3/4"
1C	--	00735.00	Vacuum Breaker Repair Kit 3/4"
1D	--	00739.50	Vacuum Breaker Cap
2	1	00704.00	Street Elbow 3/4" 90Deg
3	1	13613.00	Nipple 3/4" x 5 1/2" Brass
4	2	13606.10	Jamb Lock Nut Thin Pattern
5	2	13639.00	Nipple SS 3/4 x Close
6	2	13633.00	3/4 90 Ell F x F Brass
7	6	00912.00	1/4-20 Nylon Lock Nut
8	4	00912.00	1/4-20 Nylon Lock Nut
9	3	01526.10	Plumbing Bracket Strap
10	1	01526.00	Plumbing Support Bracket
11	3	03603.15	1/2 Solenoid Valve JE 240V/60Hz
11A	1	00738.15	Water Sol Valve Coil 220V
11B	--	03603.20	Water Sol Valve Bonnet 1/2"
11C	--	00786.00	Water Sol Plunger 1/2" & 3/4" w/spring
11D	--	00707.00	Water Sol Repair Kit JE 1/2"

ITEM NO.	NO. REQ'D	P/N	DESCRIPTION
12	1	03107.51	Flexible Black Hose 3/8"
13	1	40014.10	1/2m x 3/8" Barb Straight
14	1	13642.00	1/2" MIP Plug Brass Sq. Head
15	8	03614.00	Nipple Brass 1/2 Close
16	3	00743.10	Tee 1/2" F X F X F
17	1	40014.00	1/2m x 1/2 Barb Straigh
18	1	13602.20	Pressure Regulator 1/2
19	1	03107.00	Flexible Black Hose 1/2"
20	2	41062.00	1/2 Strainer Ball Valve
21	2	01528.00	Plumbing Support Bracket
22	2	00924.00	1/4 SS Washer
23	2	00906.00	1/4-20 X 1/2 Hexhead Bolt
24	2	40116.00	1/4 Comp x 1/4 MIP Fitting
25	1	13604.00	1/2 x 1/4 Bushing Brass
26	1	00425.54	Chemical Tubing
27	1	13618.11	Coupling 1/4" Brass
28	1	13605.45	Pressure Gauge 180-UC
29	2	03202.00	Thermometer Capillary
30	1	17534.50	Gauge Bracket

### 1.2.5. Wash Spray System

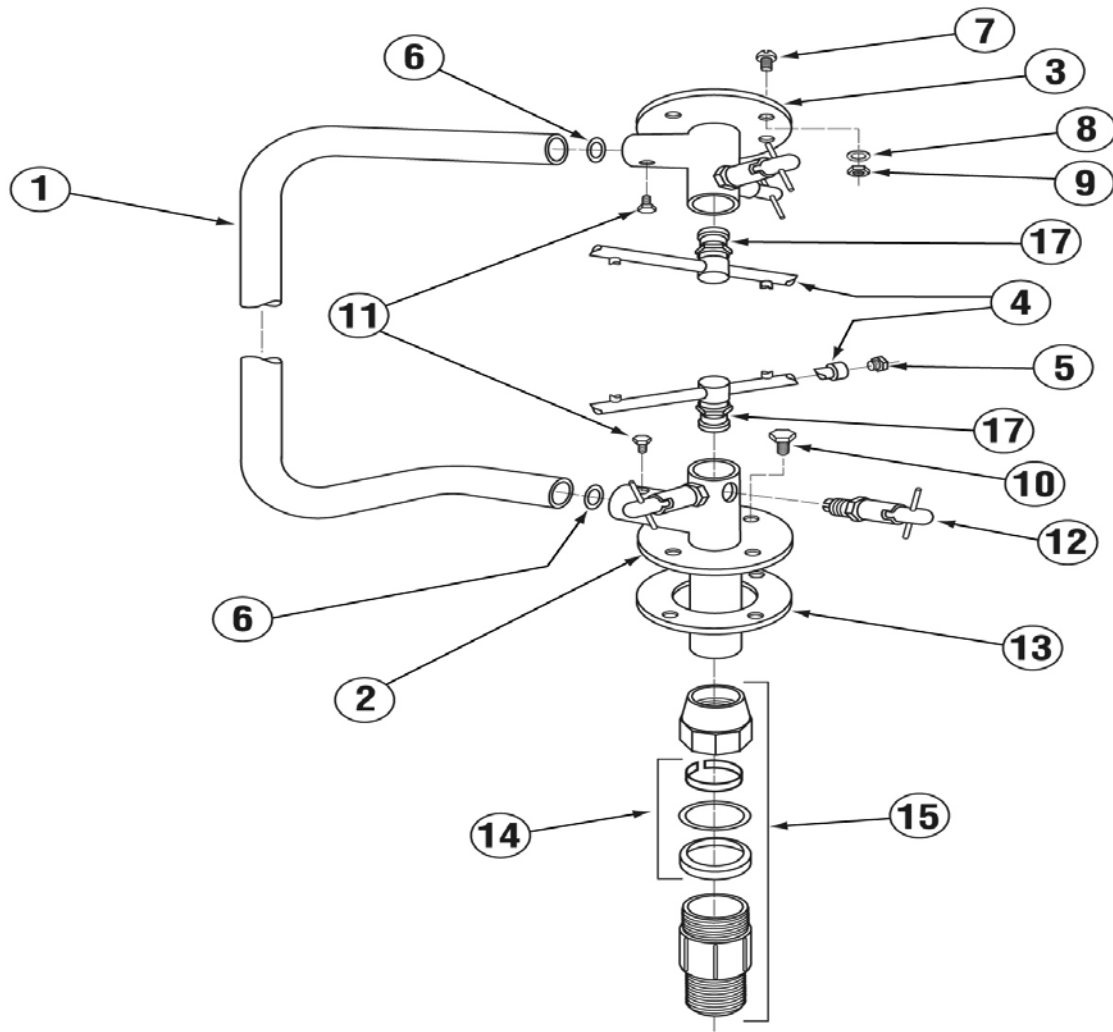

ITEM NO.	NO. REQ'D	P/N	DESCRIPTION
1	1	00303.17	Manifold
*2	1	00360.24	Lower Spray Base Assembly
**3	1	00361.10	Upper Spray Base Assembly
4	2	00304.17	Wash Spray Arm
5	4	00308.50	Spray Arm End Plug SS
6	2	00302.51	Spray Base "O" Ring
7	4	00905.00	Truss Head Bolt 1/4"-20"x1/2"
8	12	00924.00	SS Washer 1/4"

ITEM NO.	NO. REQ'D	P/N	DESCRIPTION
9	8	00912.00	Nylon Lock Nut 1/4" – 20
10	4	00914.10	Hex Head Bolt 1/4"-20"x5/8"
11	2	00966.10	Hex Head SS Bolt 10-32
12	4	00363.00	Spray Base Lock Pin
13	1	00302.00	Spray Base Gasket
14	1	00225.00	Compression Gasket
15	1	00221.20	1" Comp. Fit.x1"MIP SS
16	1	00759.17	Base Quick Release W/Nipple
17	2	00341.00	Spray Arm Bearing

\*\*P/N 00361.10 Includes Items 11,12 & 6

\*P/N 00360.24 Includes Items 11, 12 & 6



## 1.2.6. Final Rinse System Assembly

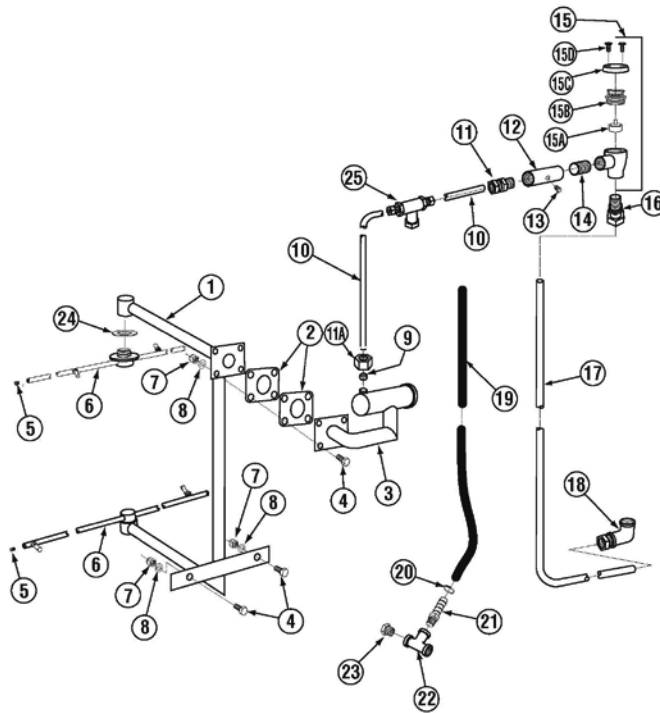

ITEM NO.	NO. REQ'D	P/N	DESCRIPTION
1	1	17401.00	Final Rinse Manifold
2	2	04305.17	Red Silicone Gasket (CMA-180)
3	1	13607.40	180VL Final Rinse Pipe Ass.
4	6	00914.00	¼"-20x5/8 Hex Bolt
5	4	00308.17	Rinse Arm SS End Plug
6	2	00304.29	^Rinse Arm w/ Bearings (180&180UC)
7	6	00912.00	¼"-20 Nylon Lock Nut
8	6	00924.00	¼"SS Washer
9	1	13607.20	3/8 Compression Fitting Sleeve
10	1	05004.10	3/8" SS Tubing
11	1	00436.20	3/8" Comp X 1/2" MIP Fitting
11A	1	13607.10	3/8 Compression Fitting Nut
12	1	13669.45	Mixing Chamber SS CMA 180UC
13	1	03232.00	1/8 Male Plug
14	1	13629.00	½" S.S. Close Nipple

ITEM NO.	NO. REQ'D	P/N	DESCRIPTION
15	1	03624.00	½" Vacuum Breaker
15A	--	03623.00	½" Vacuum Brkr Kit-
15B	--	03624.25	½" Brass Bonnet
15C	--	00739.50	¾" Vacuum Breaker Cap
15D	--	00421.51	6-32 x ¼" SS Pan Head Screw Phillips
16	1	00760 .00	5/8 Comp x 1/2" MIP Adapter
17	1	13607.44	180VL Rinse Plumbing Line
18	1	00745.00	1/2 90Deg Street Elbow
19	1	03107.00	Flexible Black Hose ½"
20	1	03101.45	Hose Clamp #4
21	1	40014.00	1/2m x 1/2 Barb Straight
22	1	00743.00	1/2 Tee F x F x F Brass (Plated)
23	1	13642.00	1/2" Male Plug Brass
24	1	4305.17	Red Silicone Gasket (CMA-180)
25	1	13607.55	CMA-180VL F.R. Thermometer Fitting

### 1.2.7. Door Assembly

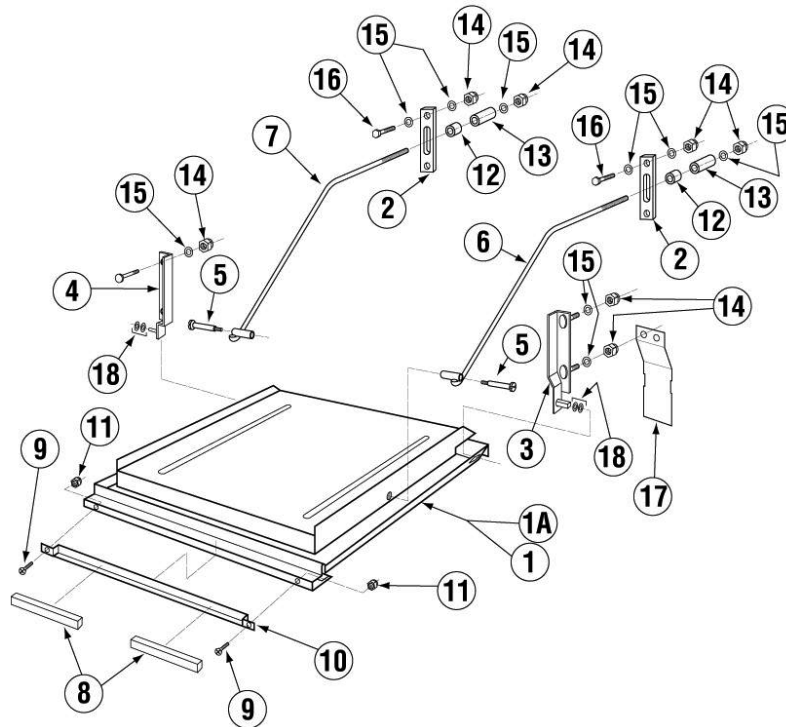

ITEM NO.	NO. REQ'D	P/N	DESCRIPTION
1	1	14506.00	Door for L-1X16
2	2	04517.60	Door Support Rod Block
3	1	14570.00	Door Hinge (RH)
4	1	14570.50	Door Hinge (LR)
5	2	04919.00	Door Rod Screw Pin for Door
6	1	04918.60	Door Support Rod Right
7	1	04919.50	Door Support Rod Left
8	3	00557.80	Door Magnet
9	2	00970.60	6 32 x 1/2" Flathead Screw

ITEM NO.	NO. REQ'D	P/N	DESCRIPTION
10	1	14558.61	Door Magnet Holder
11	2	00965.00	06-32 Lock Nut
12	2	00605.20	Door Rod Spacer
13	2	04517.15	Door Stop (Parallel)
14	10	00912.00	1/4"-20 Nylon Lock Nut
15	14	00924.00	1/4" SS Washer
16	4	00914.10	1/4"-20 x 5/8" Hex Head Bolt
17	2	14518.00	Splash Guard
18	4	00924.00	1/4 SS Washer

### 1.2.8. Pump System Assembly

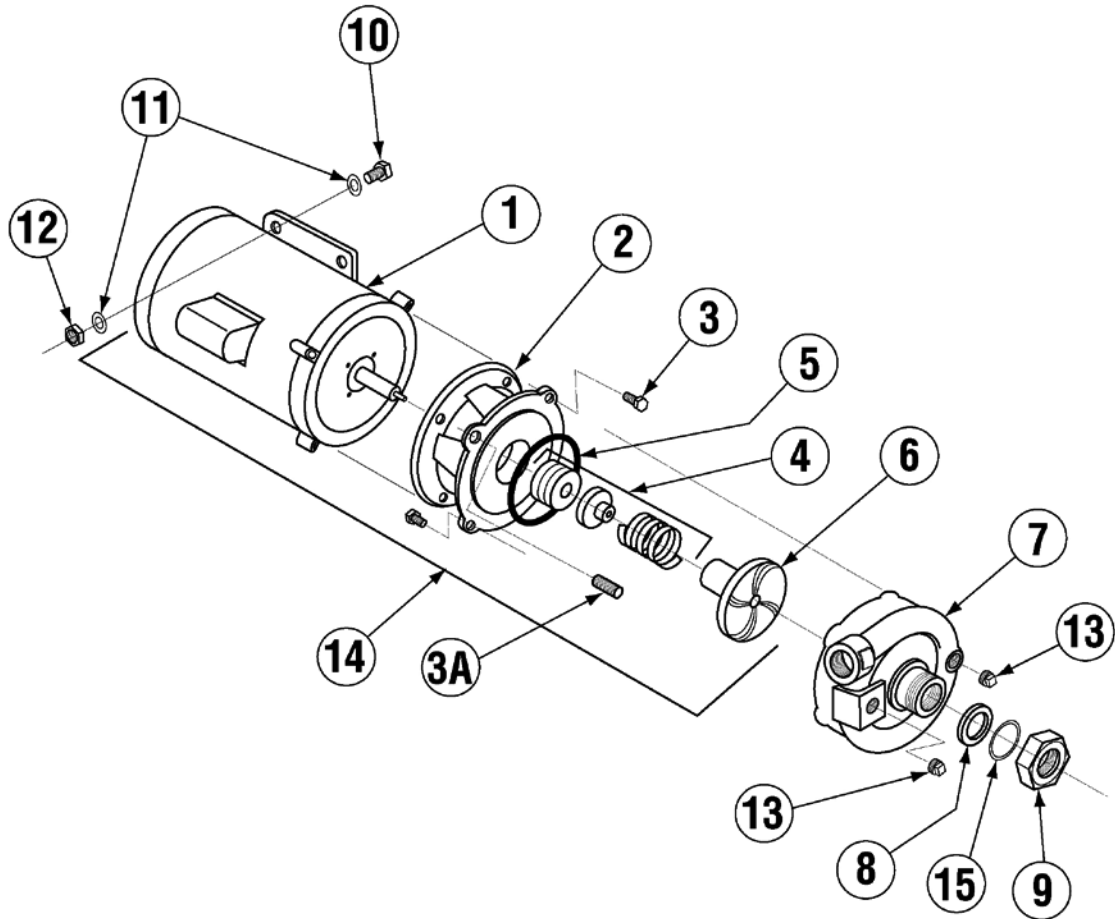

ITEM NO.	NO. REQ'D	P/N	DESCRIPTION
1	1	00201.00	Pump Motor 1 HP
2	1	04207.10	Small Pump Base
3	6	00921.00	3/8"-16 x 34" Hex Head Bolt
3A	2	00975.00	3/8-16 x 1 1/2" Stud
4	1	00206.00	Pump Seal Kit
5	1	03226.00	Pump "O" Ring
6	1	03222.05	Impeller
7	1	04207.20	Pump Cover

ITEM NO.	NO. REQ'D	P/N	DESCRIPTION
8	1	00208.00	Slip Joint Nut Gasket
9	1	04204.00	Compression Nut (2.5)
10	2	00906.00	1/4"-20 x 1/2" Hex Bolt
11	2	00924.00	1/4" SS Washer
12	2	00912.00	1/4"-20 Nylon Lock Nut
13	2	00238.00	3/8" Male Plug
*14	Assy.	00200.10	Pump Assy
15	1	00208.20	Slip Joint Nut Friction Ring

\*P/N 00200.10 Includes Items 1,2,3,4,5 and 6

### 1.2.9. Wash Tank Heater (Triangular Flange)

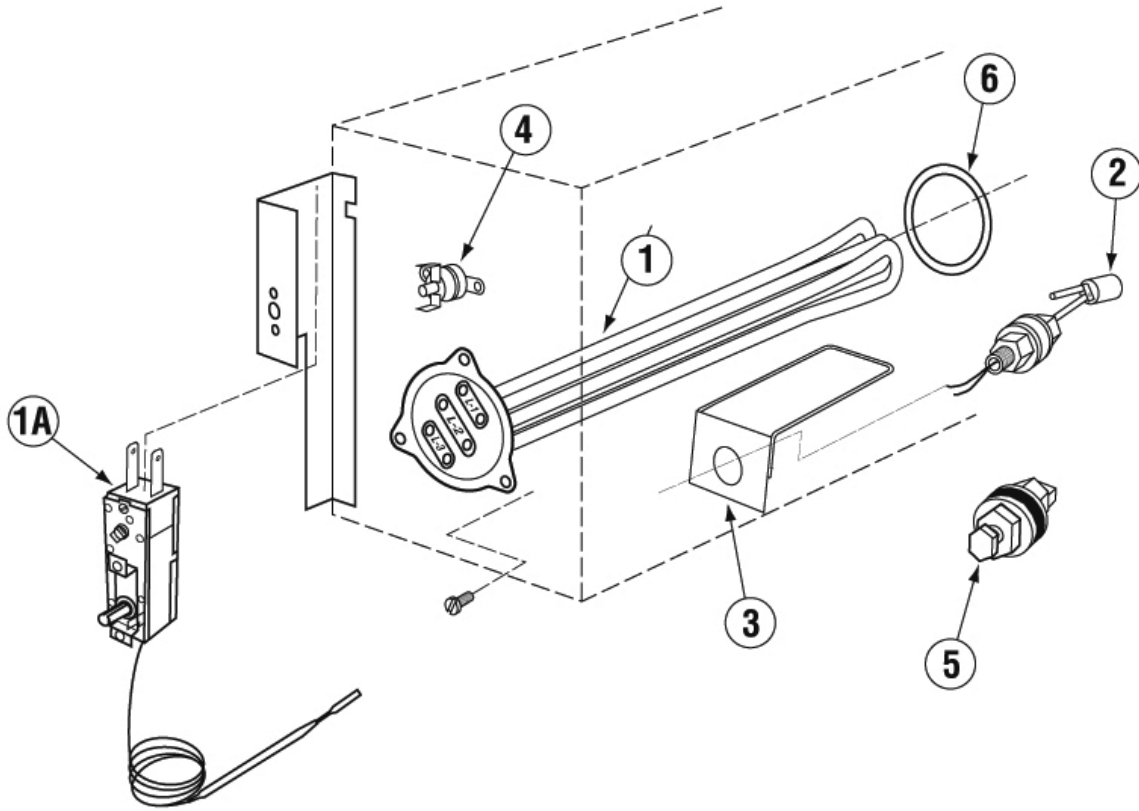

ITEM NO.	NO. REQ'D	P/N	DESCRIPTION
1	1	15518.00	Heater 6kW 220V Triangular Flange
1A	1	13417.92	Heater Thermostat
2	1	13463.14	Liquid Level Switch
3	1	13463.51	Liquid Level Switch Shield
4	1	17523.51	Hi-Limit Switch - Wash 250 Degrees
5	1	13477.20	7/8" Probe Hole Plug
6	1	15518.11	Gasket for Triangular Flange Heater

### 1.2.10. Booster Tank Heater (Triangular Flange)

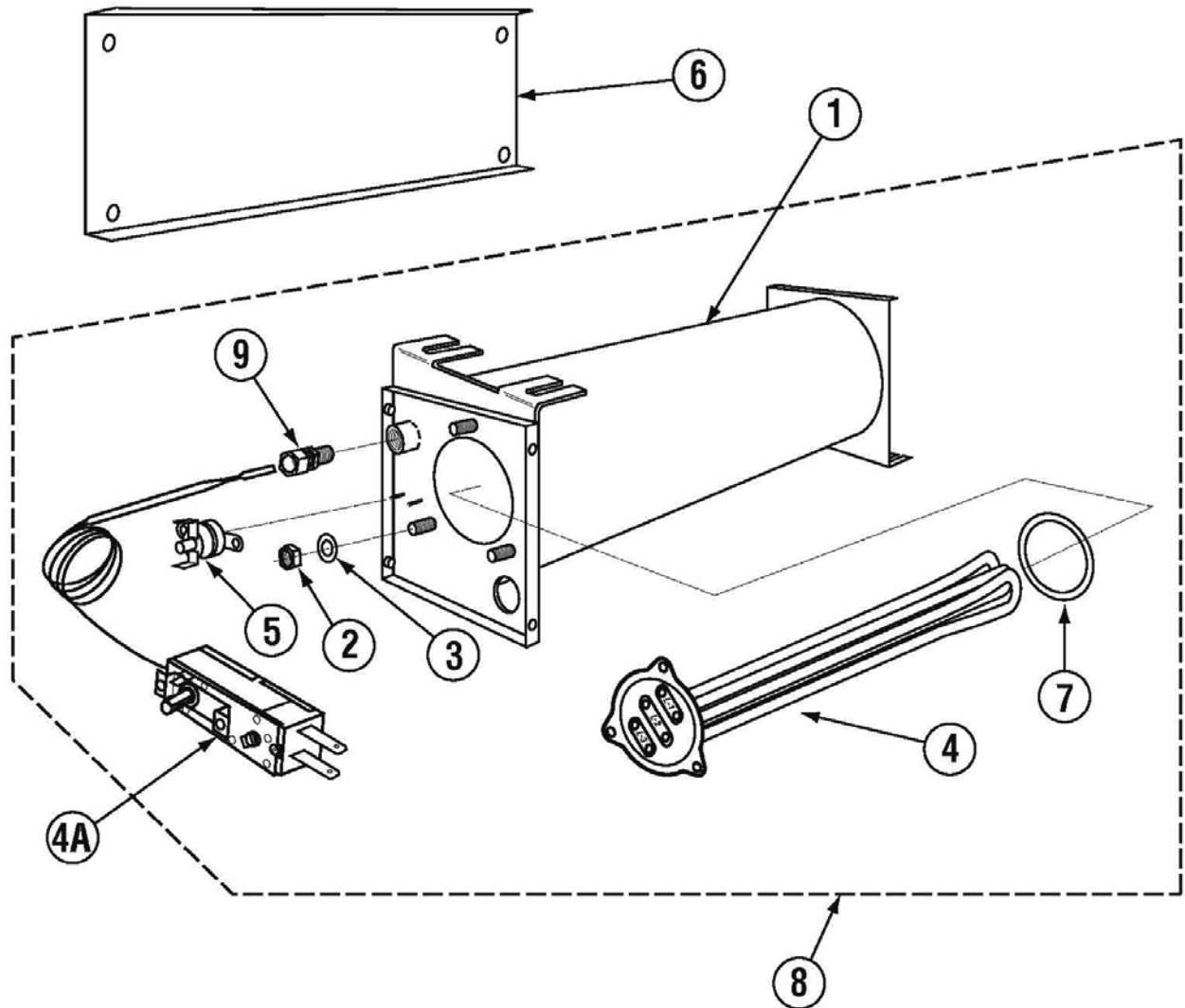

ITEM NO.	NO. REQ'D	P/N	DESCRIPTION
1	1	17550.20	Booster Tank
2	3	13805.00	Nylon Lock Nut 5/6"-18
3	3	00926.00	Washer SS 5/16"
4	1	13422.71 13422.75	240V 12KW Triangular Immersion Htr 480V 12 kW Triangular Immersion Htr
4A	1	13417.92	Thermostat 12KW Heater
5	1	17523.51	Hi-Limit Switch-Booster 250 degrees
*6	1	17520.00	Booster Heater Shield*
7	1	15518.11	Gasket for Triangular Flange Heater
8	1	17560.00	Complete Assembly
9	1	40116.00	1/4 Comp x 1/4 MIP Fitting

## 1.2.11. Control Box Assembly

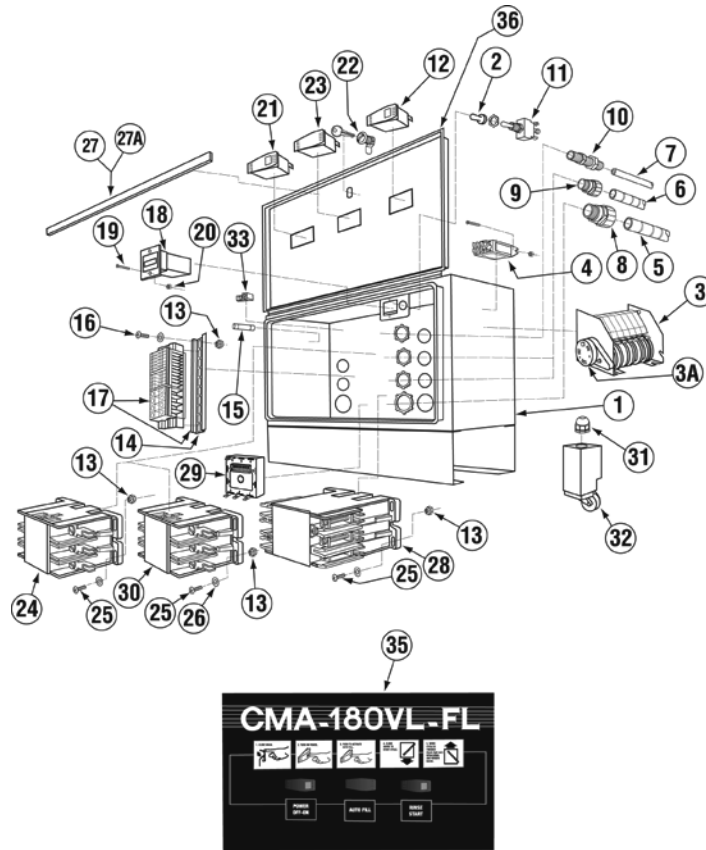

ITEM NO.	NO. REQ'D	P/N	DESCRIPTION
1	1	17503.39	CMA-180 Control Box Body
2	2	00470.10	Toggle Switch Rubber Boot
3	1*	00409.94	Timer CMA-180 VL-FL
3A	1	00500.10	Timer Motor
4	1(2*)	00631.05	Ice Cube Relay 220V
5	6 Ft.	00400.85	Conduit 1/2" Sealtite
6	6 Ft.	00400.10	Conduit 1/2" Sealtite
7	2 Ft.	00400.00	Conduit 3/8" Sealtite
8	1	00401.85	St-3/4" Straight Connector
9	1	00401.10	St-1/2" Straight Connector
10	1	00401.00	St-3/8" Straight Connector
11	1	00475.70	Delimiter Switch DPDT 15A
12	1	00421.35	Start/Fill Rocker Switch Amber 250V (Mom)
13	8	03801.00	Nylon Lock Nut 10-32
14	1	17400.06	Mountain Din Rail
15	1	13403.26	Fuse 3A/250V Slow Blow
16	2	00941.00	Pan Head Screw 10 -32 x 5/8"
17	1	17400.17	Terminal Block Assembly
17A	2	17400.04	30 Amp Terminal Block-Red
17B	3	17400.03	60 Amp Terminal Block-Black
17C	4	17400.02	85 Amp Terminal Block-Natural
17D	2	17400.08	30 Amp Terminal Block-Blue

\* Includes timer motor p/n 501.17 and microswitch 411.00

ITEM NO.	NO. REQ'D	P/N	DESCRIPTION
17E	2	17400.09	30 Amp Terminal Block-Natural
17F	1	17400.07	60 Amp Terminal Block-Green
18	1	03408.55	Counter Face Mount 220V
19	4	00911.00	Pan Head Screw 8-32 x 1/2"
20	4	00927.00	Lock Nut 8-32
21	1	00421.90	Power Switch
22	1	00449.50	Keyless Lock
23	1	00421.89	Rocker Switch Auto Fill
24	1	00404.85	Motor Contactor 208/240V 20A
25	6	13825.00	Pan Head Screw 8-31 x 1"
26	6	04806.00	#10 Brass Washer
27	2	17503.17	Control Box Sponge Long
27A	2	17503.18	Control Box Sponge Short
28	1**	13003.17	Contactor 60A 3 Pole 220V
29	1	13418.60	Dip Switch Timer 230V
30	1	13003.55	Heater Contactor 30 Amp
31	1	00562.60	Door Roller Switch Connector
32	1	00562.00	Door Roller Switch
33	1	13426.50	Ground Block
34	1	00421.78	Illuminated Plug
35	1	006231.80	Control Panel Label CMA-180VL-FL
36	1	17503.29	Control Box Lid

\*\* Only for the machines with booster heater

### 1.2.12. Heat Recovery System Control Box

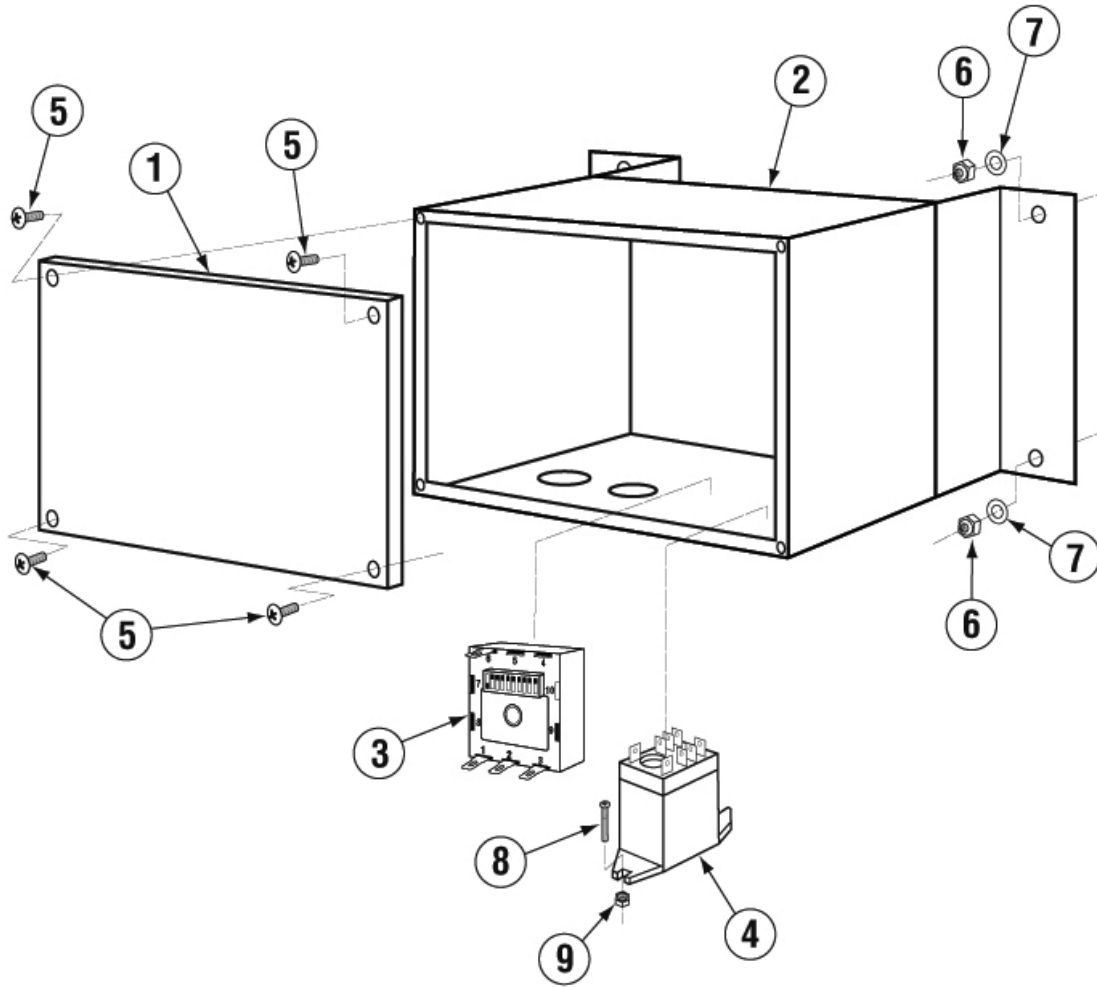

ITEM NO.	NO. REQ'D	P/N	DESCRIPTION
1	1	13905.23	Transformer Box Lid
2	1	13905.13	Transformer Box
3	1	13418.60	Dip Switch Timer 230 V
4	1	00631.05	Ice Cube Relay 220V 12 Amp
5	4	00940.50	10-32 X 3/8 Truss Head Screw
6	4	0013805	5/16-18 Nylon Insert Lock Nut
7	4	00926.00	5/16 SS Washer
8	2	00907.00	6-32 X 1/2 SS Panhead Screw
9	2	00965.00	6-32 Nylon Insert Lock Nut

### 1.2.13. Door Safety Interlock (DSI) Assembly

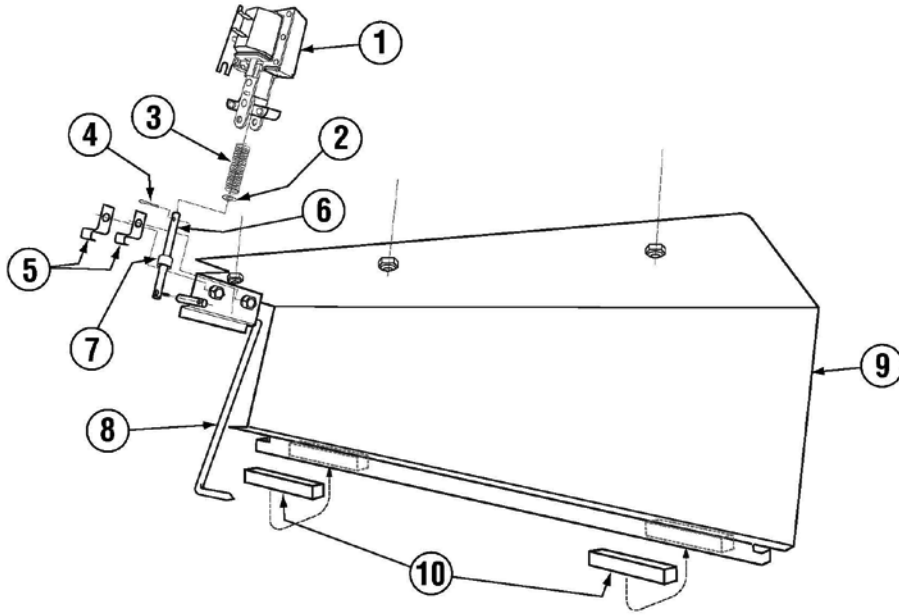

ITEM NO.	NO. REQ'D	P/N	DESCRIPTION
1	1	00100.05	Drain Ball Solenoid 240V
2	1		
3	1	00105.00	Solenoid Spring
4	1	00900.10	Cotter Pin 1/8" x 1"
5	2	13901.12	Wash Curtain Support ('07) (CMA-44)
6	1	17714.10	CMA-180VL DSI Solenoid Rod
7	1	13972.10	Conveyor Switch Rod Sleeve
8	1	17714.11	CMA-180VL DSI Door Rod
9	1	17675.00	CMA-180-VL-FL Magnet Holder
10	2	00557.80	Door Magnet