

MODEL CMA-66

PARTS MANUAL

REV 1.10B



CMA DISHMACHINES
12700 KNOTT AVENUE
GARDEN GROVE
CALIFORNIA 92841

800-854-6417
FAX 714-895-2141

Table of Contents

CMA-66

- 1. PARTS MANUAL..... 4**
- 1.1. Initial Parts Kit (P/N 13996.81)..... 4
- 1.2. Initial Parts Kit (P/N 13996.80)..... 5
- 1.3. Exploded View Drawings..... 6
 - 1.3.1. Cabinet Assembly 6
 - 1.3.2. Cabinet Assembly (Old)..... 7
 - 1.3.3. Cabinet Assembly (Effective 08/2001)..... 8
 - 1.3.4. 480V Control Box Assembly p/n 18611.48 (480V machines only) 9
 - 1.3.5. Control Box Assembly 10
 - 1.3.6. Control Box Assembly (Old Models) 11
 - 1.3.7. Curtain and Optional Vent System 12
 - 1.3.8. Temperature Control System 13
 - 1.3.9. Wash Pump Assembly..... 14
 - 1.3.10. Drain System Assembly..... 15
 - 1.3.11. Plumbing System Assembly (Auto-Fill) 16
 - 1.3.12. Plumbing System Assembly (Final Rinse)..... 17
 - 1.3.13. Plumbing System Assembly (Old Models) 18
 - 1.3.9. Wash System Assembly 19
 - 1.3.10. Wash System assembly (Old Models) 20
 - 1.3.11. Rocker Arm Assembly..... 21
 - 1.3.12. Rocker Arm Assembly (Old Models)..... 22
 - 1.3.13. Trip Switch Assembly p/n 13475.06..... 23
 - 1.3.14. Paddle Switch Assembly (Old Models)..... 24
- 2. TABLE LIMIT SWITCH INSTRUCTIONS (P/N 13469.20) 25**
- 3. DRAIN WATER TEMPERING KIT (OPTIONAL) 27**

1. Parts Manual

1.1. Initial Parts Kit (P/N 13996.81)

P/N	DESCRIPTION	Qty
00201.85	Pump Motor, 1HP, 3Ph, 60 Hz, 220V	1
00206.00	Pump Seal Kit	1
00208.40	Slip Joint Nut "O" Ring Buna N70	1
00421.83	M-2 Power Rocker Switch, Red	1
00557.30	Kynar Reed Switch Gray, 110/220V, 12'	1
00557.56	Kynar Reed Switch Black, 110/220V, 12'	1
00631.05	Ice Cube Relay 220V 12Amp	1
00706.00	3/4" Water Solenoid Repair Kit JE	1
00707.00	1/2" Water Solenoid Repair Kit JE	1
00735.00	3/4" Vac Breaker Rep Kit Watts	1
00738.15	3/4" & 1/2" Solenoid Coil JE 220V	1
03202.00	Thermometer (Capillary)	1
03226.00	Pump O-Ring Gasket	1
03623.00	1/2" Vac Breaker Repair Kit Watts	1
13003.50	Contactator, 30-Amp	1
13003.70	Toggle Switch SPDT 20AMP	1
13012.26	M-2P Motor Contactator, 220V	1
13403.26	Fuse, 3-Amp/250V Slow Blow	2
13417.80	Immersion Heater, 3Ph/1Ph, 208-230V, 10kW	1
13418.20	Delay On Break Timer 230V 6-240Sec	1
13418.25	Auto Fill Timer 230v	1
13463.10	Liquid Level Switch, SS – M-2	1
13501.85	Motor 1/3Hp 200-230/460 60hz 3ph	1
13507.65	Cma Bearing Assy (New Dec 2007)	1
13508.70	Heavy Duty Clutch Spring	1

1.2. Initial Parts Kit (P/N 13996.80)

P/N	DESCRIPTION	Qty
00201.85	Pump Motor, 1HP, 3Ph, 60 Hz, 220V	1
00206.00	Pump Seal Kit	1
00208.00	Slip Joint Nut Gasket	1
00411.00	Micro Switch	1
00421.83	CMA-44 Power Rocker Switch, Red	1
00421.87	CMA-44 Heater Rocker Switch, White	1
00557.30	Kynar Reed Switch Gray, 110/220V, 12'	1
00557.56	Kynar Reed Switch Black, 110/220V, 12'	1
00707.00	½" Water Solenoid Repair Kit JE	1
00738.15	¾" & ½" Solenoid Coil JE 220V	1
03202.00	Thermometer (Capillary)	1
03226.00	Pump O-Ring Gasket	1
03623.00	½ Vac Breaker Repair Kit Watts	1
13003.50	Contactactor, 30-Amp	1
13003.70	Toggle Switch SPDT 20AMP	1
13012.26	CMA-44P Motor Contactactor, 220V	1
13403.26	Fuse, 3-Amp/250V Slow Blow	2
13417.80	Immersion Heater, 3Ph/1Ph, 208-230V, 10kW	1
13418.85	60-Second Timer Relay	1
13463.10	Liquid Level Switch, SS – CMA-44	1
13501.85	Motor 1/3Hp 200-230/460 60hz 3ph	1
13507.50	Cam Bearing, SS	1
13508.60	Swivel Hook Spring Assembly	1

1.3. Exploded View Drawings

1.3.1. Cabinet Assembly

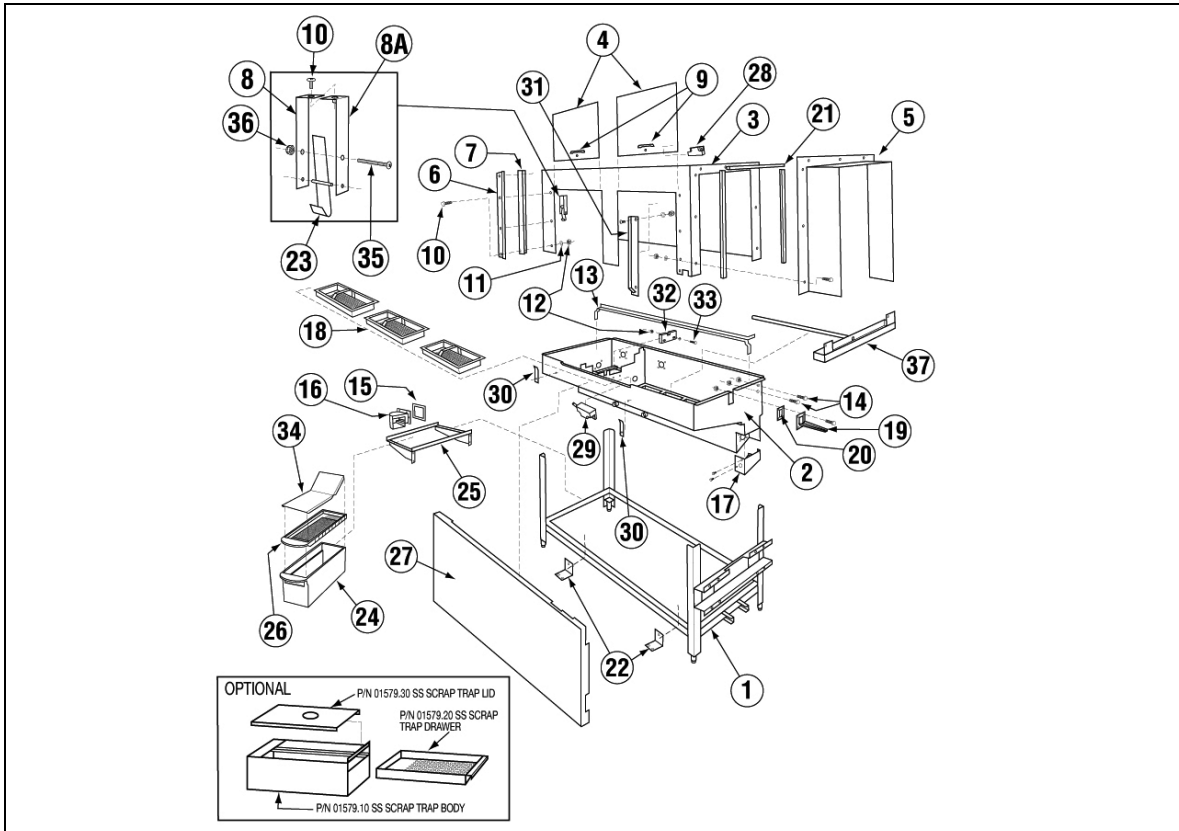

ITEM NO.	NO. REQ'D	P/N	DESCRIPTION
1	1	13903.09	CMA 44 Stand
2	1	13902.05	L-R CMA-44P Pan
		13902.15	R-L CMA-44P Pan
3	1	13900.06	L-R CMA-44P Wrapper
		13900.16	R-L CMA-44P Wrapper
4	1	01506.30	Door
5	2	13901.10	Wrapper Shield
6	2	01554.30	Door Guide
7	2	00636.10	Door Guide Plastic
8	1	13915.00	Door Latch Bracket
8A	1	13915.96	Door Latch Bracket W/Nut
9	1	00535.30	Door Handle
10	27	00905.00	1/4-20 x 1/2" Trusshead Bolt
11	60	00924.00	1/4" Washer, SS
12	52	00912.00	1/4-20 Nylon Lock Nut
13	2	13906.00	Tray Track Rail
14	8	00914.10	1/4-20 x 5/8" Hex Head Bolt
15	1	13511.26	Overflow Chute Gasket
16	1	13511.06	L-R Overflow Chute
17	1	13927.06	L-R Heater Cover

ITEM NO.	NO. REQ'D	P/N	DESCRIPTION
17	1	13927.16	R-L Heater Cover
18	3	13910.82	Strainer Basket, Wash/Rinse
19	1	13913.00	Drip Chute
20	1	13542.00	Drip Chute Gasket
21	4	03705.00	Foam Tape
22	2	13910.06	Drain Valve Handle Support
23	1	13701.00	Door Latch
24	1	01577.10	Scrap Trap Body Molded
25	1	17579.00	Scrap Trap Holder
26	1	01577.21	SS Scrap Trap Drawer
27	1	13912.06	Splash Shield
28	1	00557.60	Reed Switch Magnet
29	1	00557.30	Kynar Reed Switch Only 110/220
30	2	13912.81	Splash Shield Clip
31	1	13704.08	L-R Curtain Splash Shield
		13704.06	R-L Curtain Splash Shield
32	1	13522.00	Conveyor bar guide
33	2	00962.00	1/4"-20x1" Hexhead Bolt
34	1	01577.36	Scrap Trap Cover SS (Hi Temp)
35	1	00960.00	8-32x1-1/2" Panhead Screw
36	1	00927.00	8-32 Nylon Lock Nut
37	1	13560.00	Rinse Collector Pan

Parts Manual

1.3.2. Cabinet Assembly (Old)

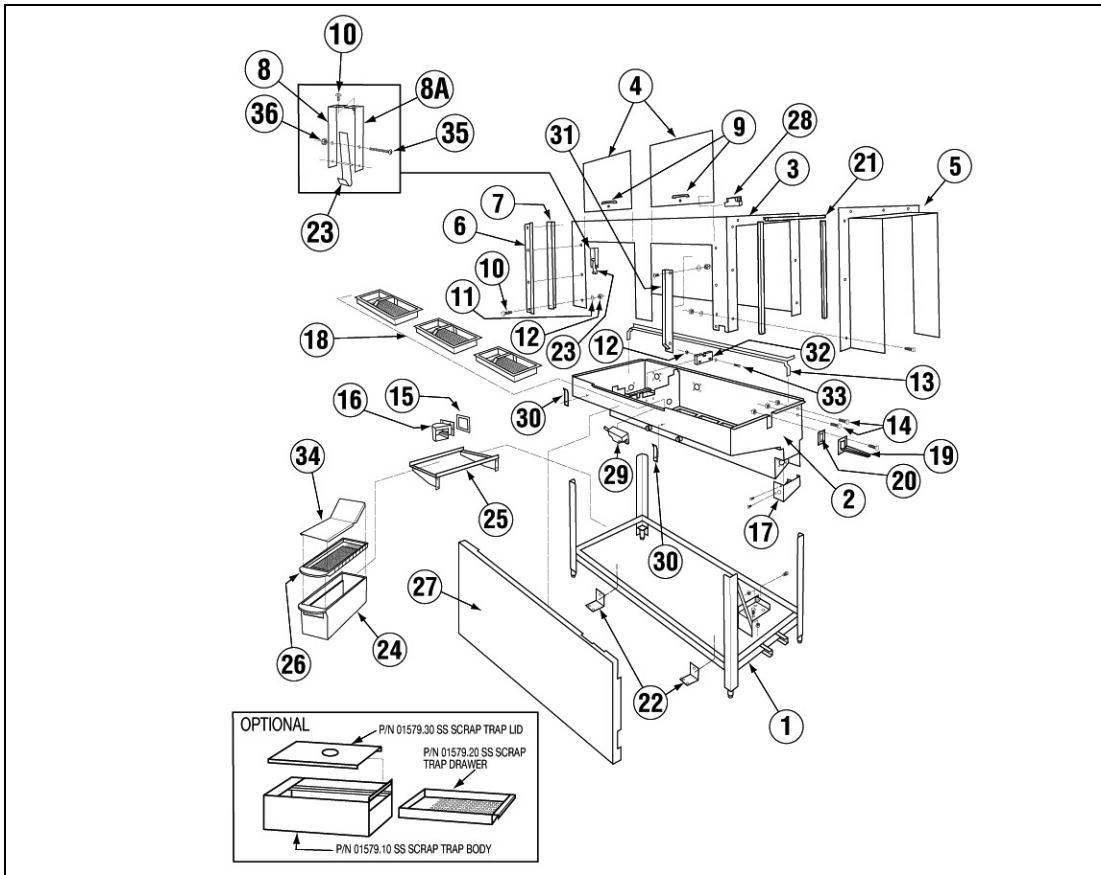

ITEM NO.	NO. REQ'D	P/N	DESCRIPTION
1	1	13903.05	L-R CMA-44P Frame Stand
		13903.15	L-R CMA-44P Frame Stand
2	1	13902.05	L-R CMA-44P Pan
		13902.15	R-L CMA-44P Pan
3	1	13900.06	L-R CMA-44P Wrapper
		13900.16	R-L CMA-44P Wrapper
4	1	01506.30	Door
5	2	13901.10	Wrapper Shield
6	2	01554.30	Door Guide
7	2	00636.10	Door Guide Plastic
8	1	13915.00	Door Latch Bracket
8A	1	13915.96	Door Latch Bracket W/Nut
9	1	00535.30	Door Handle
10	27	00905.00	1/4-20 x 1/2" Trusshead Bolt
11	60	00924.00	1/4" Washer, SS
12	52	00912.00	1/4-20 Nylon Lock Nut
13	2	13906.00	Tray Track Rail
14	8	00914.10	1/4-20 x 5/8" Hex Head Bolt
15	1	13511.26	Overflow Chute Gasket
16	1	13511.06	L-R Overflow Chute
17	1	13927.06	L-R Heater Cover

ITEM NO.	NO. REQ'D	P/N	DESCRIPTION
17	1	13927.16	R-L Heater Cover
18	3	13910.82	Strainer Basket, Wash/Rinse
19	1	13913.00	Drip Chute
20	1	13542.00	Drip Chute Gasket
21	4	03705.00	Foam Tape
22	2	13910.06	Drain Valve Handle Support
23	1	13701.00	Door Latch
24	1	01577.10	Scrap Trap Body Molded
25	1	17579.00	Scrap Trap Holder
26	1	01577.20	Scrap Trap Drawer Molded
27	1	13912.06	Splash Shield
28	1	00557.60	Reed Switch Magnet
29	1	00557.30	Kynar Reed Switch Only 110/220
30	2	13912.81	Splash Shield Clip
31	1	13704.08	L-R Curtain Splash Shield
		13704.06	R-L Curtain Splash Shield
32	1	13522.00	Conveyor bar guide
33	2	00962.00	1/4"-20x1" Hexhead Bolt
34	1	01577.36	Scrap Trap Cover SS (Hi Temp)
35	1	00960.00	8-32x1-1/2" Panhead Screw
36	1	00927.00	8-32 Nylon Lock Nut

Parts Manual

1.3.3. Cabinet Assembly (Effective 08/2001)

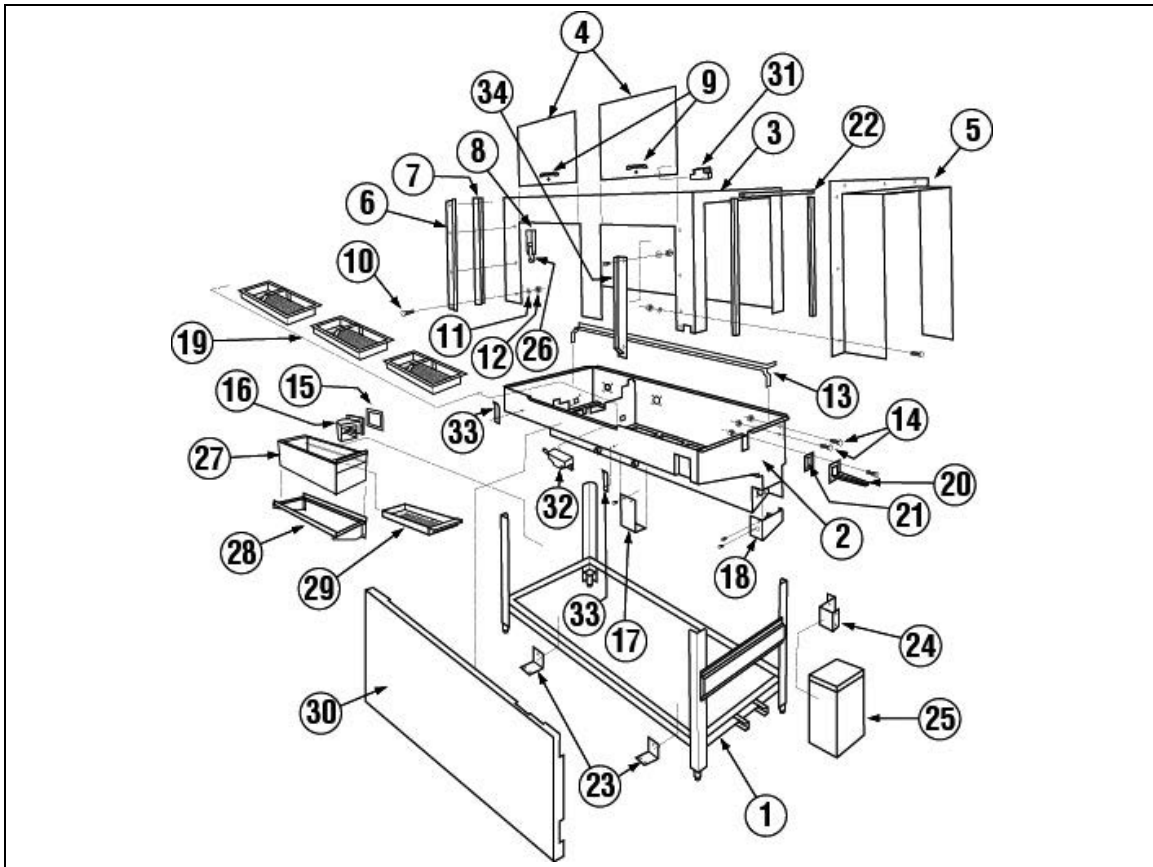

ITEM NO.	NO. REQ'D	P/N	DESCRIPTION
1	1	13903.36	Frame Stand
2	1	13902.36	L-R Pan
		13902.46	R-L Pan
		13900.36	L-R Wrapper
3	1	13900.46	R-L Wrapper
		01506.30	Door
4	2	01506.30	Door
5	2	13901.10	Wrapper Shield
6	4	01554.30	Door Guide
7	4	00636.10	Door Guide Plastic
8	4	13915.00	Door Latch Bracket
9	2	00535.30	Door Handle
10	26	00905.00	1/4-20 x 1/2" Trusshead Bolt
11	60	00924.00	1/4" Washer, SS
12	52	00912.00	1/4-20 Nylon Lock Nut
13	2	13906.36	Tray Track Rail
14	8	00914.10	1/4-20 x 5/8" Hex Head Bolt
15	1	13511.26	Overflow Chute Gasket
16	1	13511.06	L-R Overflow Chute
		13511.16	R-L Overflow Chute
17	1	13408.82	Trip Switch Cover

ITEM NO.	NO. REQ'D	P/N	DESCRIPTION
18	1	13927.06	L-R Heater Cover
		13927.16	R-L Heater Cover
19	3	13910.82	Strainer Basket, Wash/Rinse
20	1	13913.00	Drip Chute
21	1	13542.00	Drip Chute Gasket
22	4	03705.00	Foam Tape
23	2	13910.06	Drain Valve Handle Support
24	1	13504.26	Gearbox Cover Mount (Optional)
25	1	13504.06	Gearbox Cover (Optional)
26	2	13701.00	Door Latch
27	1	01579.10	Scrap Trap Body
28	1	17579.00	Scrap Trap Holder
29	1	01579.20	Scrap Trap Drawer
30	1	13912.36	Splash Shield
31	2	00557.60	Reed Switch Magnet
32	2	00557.26	Reed Switch
33	2	13912.81	Splash Shield Clip
34	1	13704.08	L-R Curtain Splash Shield
		13704.18	R-L Curtain Splash Shield

Parts Manual

1.3.4. 480V Control Box Assembly p/n 18611.48 (480V machines only)

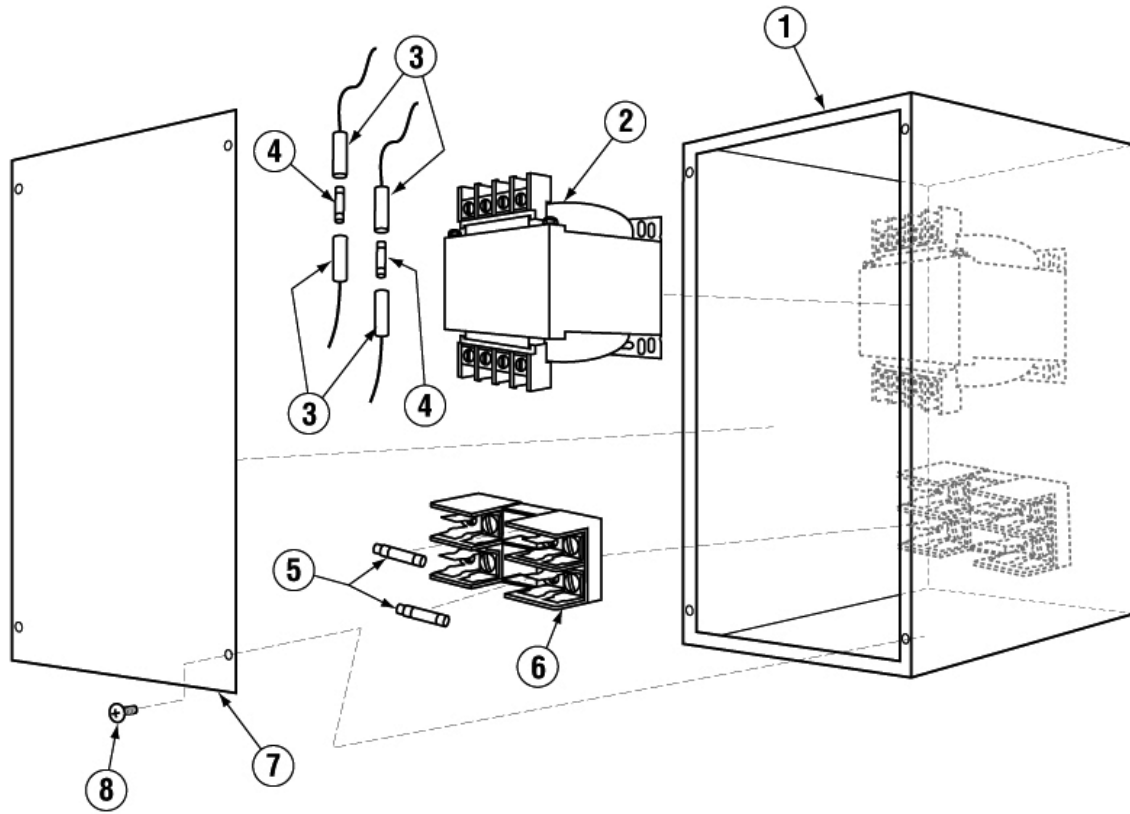

ITEM NO.	NO. REQ'D	P/N	DESCRIPTION
1	1	13905.12	Transformer Box
2	1	13423.82	Transformer 480V - 240V
3	2	13403.21	Fuse Holder - Inline
4	2	13403.40	Fuse 1.25 Amp 230V Slow Blow
5	2	13402.10	Fuse 1.50 Amp 600V Slow Blow
6	1	13420.10	Fuse Clip 2-Poll, Pressure Plate
7	1	13905.22	Transformer Box Lid
8	4	00940.50	10-32 X 3/8 Truss Head Screw

Parts Manual

1.3.5. Control Box Assembly

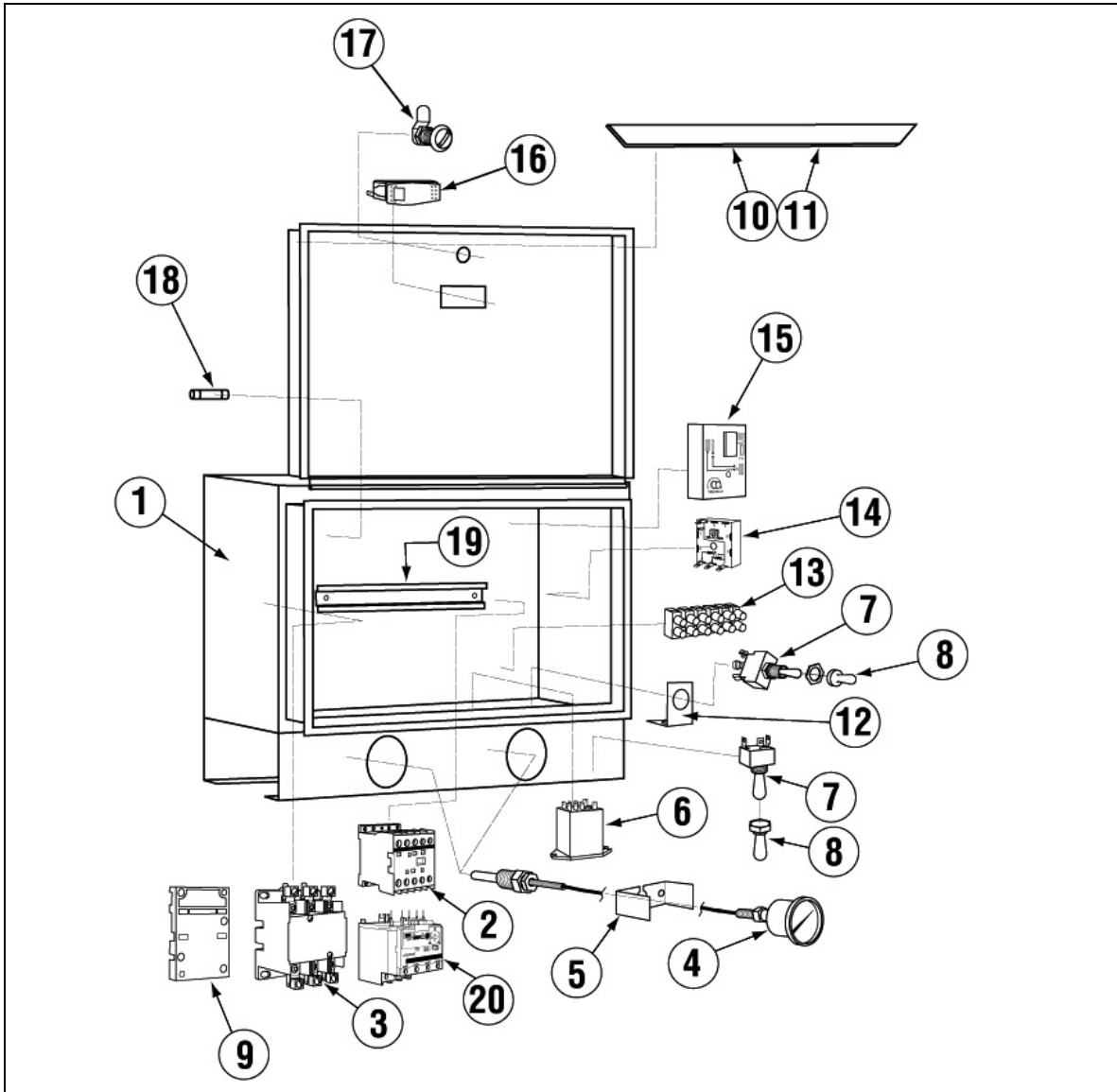

ITEM NO.	NO. REQ'D	P/N	DESCRIPTION
1	1	13904.06	Control Box w/Lid
2	1	13012.26	Motor Contactor, 220V
3	4	13003.50	Contactor, 30-Amp
4	2	03202.00	Thermometer
5	2	03202.08	Thermometer Bracket
6	1	00631.05	Ice Cube Relay 220 V
7	2	13003.70	Toggle Switch SPDT 20AMP
8	2	00470.10	Toggle Switch Rubber Boot
9	1	13003.62	Din Rail Mounting Bracket
10	2	17503.17	Control Box Sponge, Long

ITEM NO.	NO. REQ'D	P/N	DESCRIPTION
11	2	17503.18	Control Box Sponge, Short
12	1	00474.00	Toggle Switch Bracket
13	1	00454.06	6-Pole Terminal Block
14	2	13418.20	Delay On Break Timer 230V 6-240Sec
15	1	13418.25	Auto Fill Timer
16	1	00421.83	Power Rocker Switch, Red
17	1	00449.50	Lock, Keyless
18	2	13403.26	Fuse, 3-Amp/250V Slow Blow
19	1	13003.60	Starter DIN Rail
20	1	13013.30	1/3 HP Overload Relay 1.2amp-1.8Amp

Parts Manual

1.3.6. Control Box Assembly (Old Models)

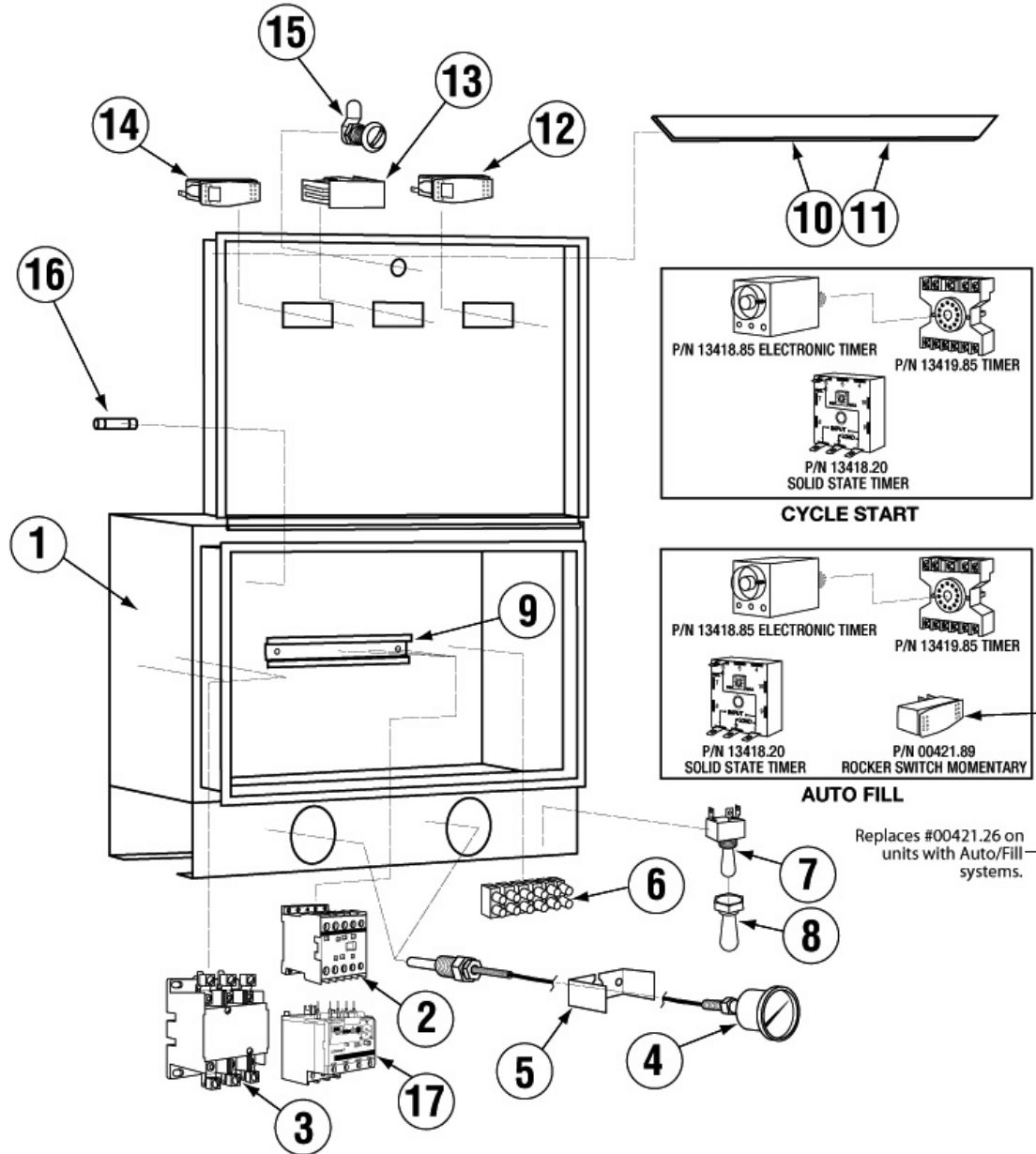

ITEM NO.	NO. REQ'D	P/N	DESCRIPTION
1	1	13904.06	Control Box w/Lid
2	3	13012.26	Motor Contactor, 220V
3	2	13003.50	Contactors, 30-Amp
4	2	03202.00	Thermometer
5	2	03202.08	Thermometer Bracket
6	1	00454.06	6-Pole Terminal Block
7	1	13003.70	Timer Relay Override Switch
8	1	00470.10	Toggle Switch Rubber Boot
9	1	13003.60	Starter DIN Rail

ITEM NO.	NO. REQ'D	P/N	DESCRIPTION
10	2	17503.17	Control Box Sponge, Long
11	2	17503.18	Control Box Sponge, Short
12	1	00421.87	Rocker Switch, White
13	1	00421.26	Rocker Switch Hole Plug
14	1	00421.83	Power Rocker Switch, Red
15	1	00449.50	Lock, Keyless
16	2	13403.26	Fuse, 3-Amp/250V Slow Blow
17	1	13013.30	1/3 HP Overload Relay 1.2amp-1.8Amp

Parts Manual

1.3.7. Curtain and Optional Vent System

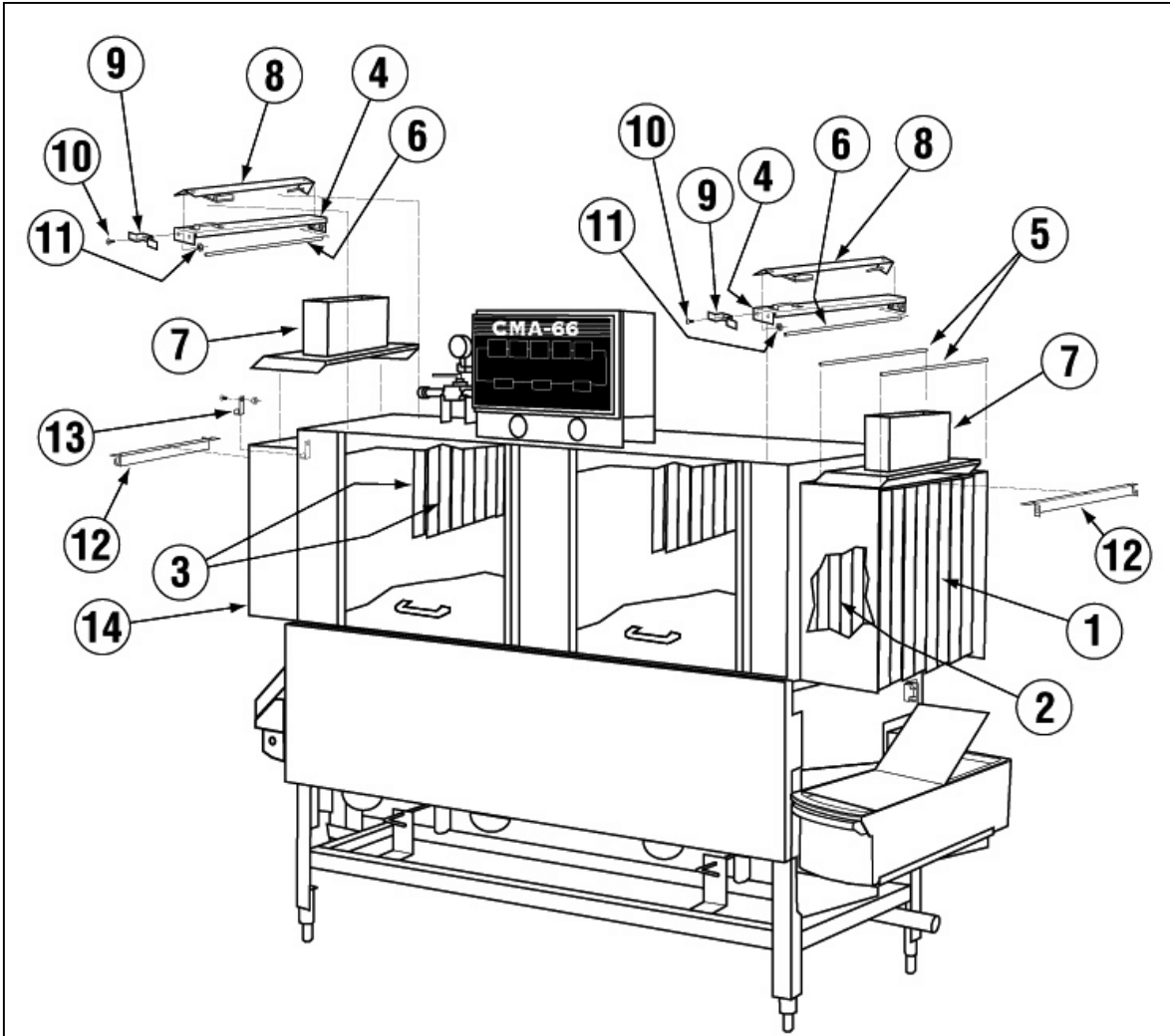

ITEM NO.	NO. REQ'D	P/N	DESCRIPTION
1	2	13702.25	Curtain, 20-5/8" x 15"
2	1	13702.15	Curtain, 20-5/8" x 11"
3	4	13702.30	Curtain, 24-5/8" x 15"
4	2	13704.26	Double Curtain Splash Guard Bracket
5	3	13705.00	Curtain Rod, Short
6	4	13705.10	Curtain Rod, Long
7	1	13901.84	Hood Adapter Set

ITEM NO.	NO. REQ'D	P/N	DESCRIPTION
8	2	13704.16	Dual Curtain Holder (Right to Left)
		13704.36	Dual Curtain Holder (Left to Right)
9	2	13704.46	Dual Curtain Rod Stop
10	4	00907.00	6-32 x 1/2" Pan Head Screw
11	4	00965.00	6-32 Nylon Lock Nut
12	2	13901.30	Outer Wrap Shield Curtain Support
13	2	13901.35	Inner Wrap Shield Curtain Support
14	2	13901.10	Wrapper Shield

1.3.8. Temperature Control System

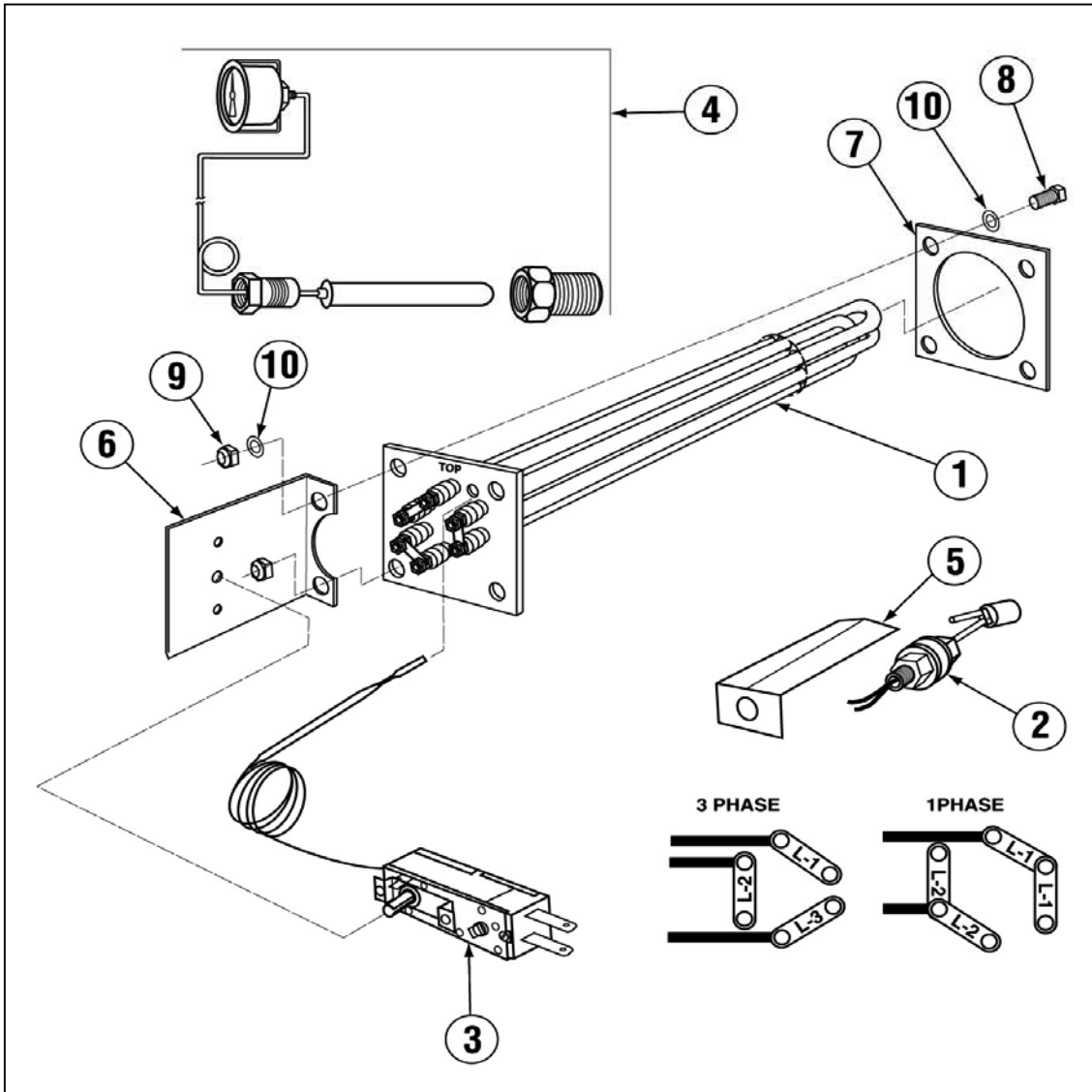

ITEM NO.	NO. REQ'D	P/N	DESCRIPTION
1	1	13417.80	Immersion Heater, 3Ph, 240V, 10kW*
2	1	13463.10	Liquid Level Switch, SS
3	1	13417.89	Thermostat 12KW Heater
4	1	03202.00	Thermometer
5	1	13463.50	Liquid Level Switch Shield

* Includes P/N 13417.89 Thermostat w/c can be ordered separately

ITEM NO.	NO. REQ'D	P/N	DESCRIPTION
6	1	13416.10	Thermostat Bracket
7	1	13417.45	Heater Gasket
8	4	00901.00	5/16 – 18 x 1" Hexhead Bolt
9	4	13805.00	5/16 – 18 Nylon Nut
10	8	00926.00	5/16" SS washer

Parts Manual

1.3.9. Wash Pump Assembly

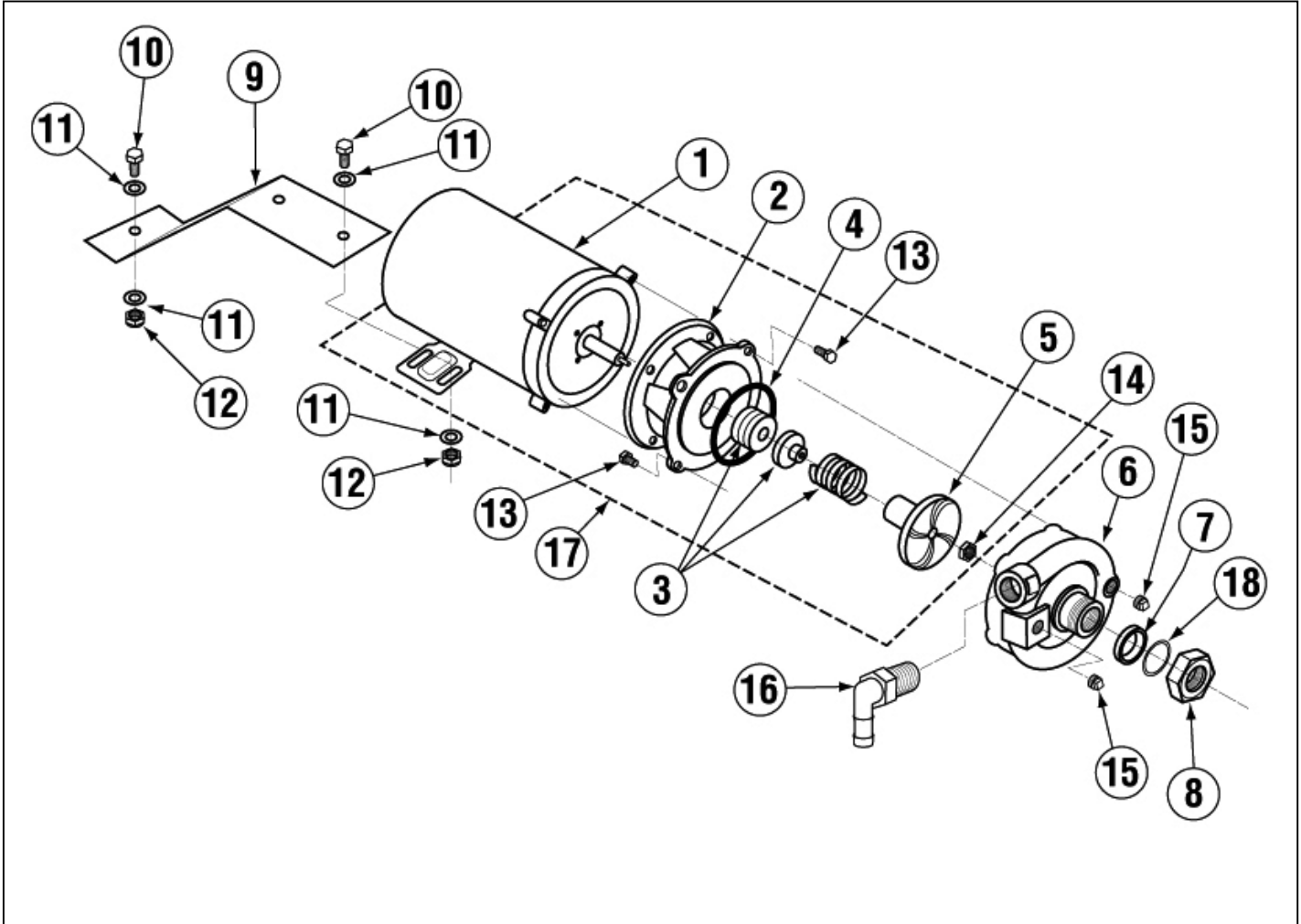

ITEM NO.	NO. REQ'D	P/N	DESCRIPTION
1	2	00201.85	Pump Motor, 1HP, 3Ph, 60 Hz, 220V
2	2	03224.00	Pump Base Mount
3	2	00206.30	Pump Seal Kit New
4	2	03226.00	Pump O-Ring Gasket
5	2	03222.10	Impeller (Open) SS
6	2	04206.00	Pump Cover
7	2	00208.00	Slip Joint Nut Gasket
8	2	04204.00	Compression Nut, 2.5"
9	2	13916.40	Motor Support Bracket

ITEM NO.	NO. REQ'D	P/N	DESCRIPTION
10	6	00906.00	1/4-20 x 1/2" Hex Bolt
11	12	00922.00	1/4" Lock Star Washer
12	6	00912.00	1/4-20 Nylon Lock Nut
13	16	00921.00	3/8-16 x 3/4" SS Hex Head Bolt
14	2	13829.00	7/16-20 Thin Nylon Lock Nut
15	4	00238.00	3/8" Male Plug
16	2	00704.85	1", 90° Elbow*
17	2	00200.85	Motor Assembly, 1HP, 3Ph, 220V, 60 Hz**
18	2	00208.20	Slip Joint Nut Friction Ring

*For CMA-44 R-L only.

**Includes Items 1, 2, 3, 4, 5 and 14.

1.3.10. Drain System Assembly

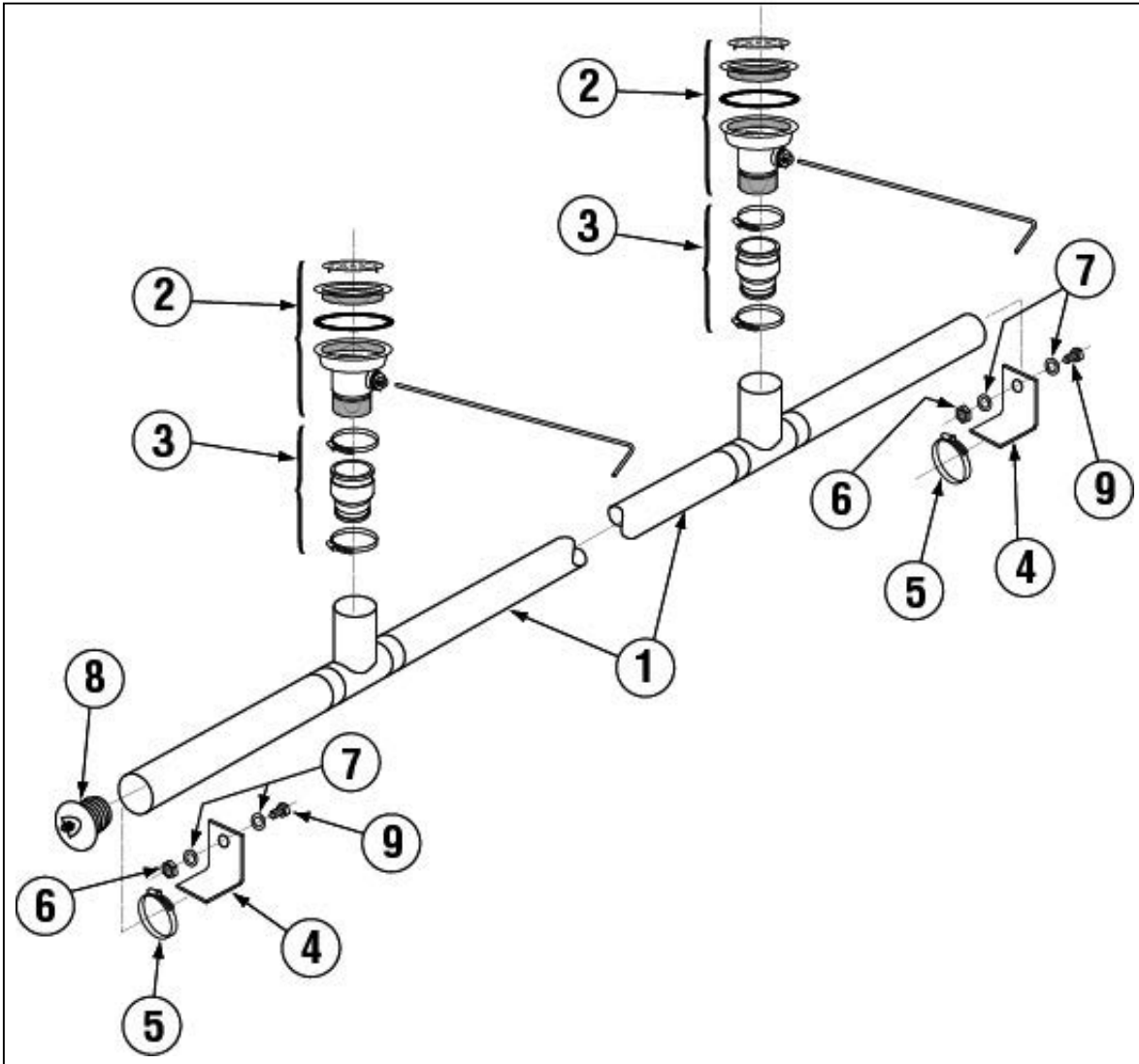

ITEM NO.	NO. REQ'D	P/N	DESCRIPTION
1	1	13001.85	Drain Manifold
2	2	20500.06	Waste Drain Valve
3	2	01317.17	1-1/2" x 2" No Hub
4	2	13001.82	Drain Pipe Support Bracket
5	2	50109.00	Hose Clamp

ITEM NO.	NO. REQ'D	P/N	DESCRIPTION
6	2	00912.00	1/4-20 Lock Nut
7	4	00924.00	1/4" Washer, SS
8	1	13024.00	Dynamite Plug, 2"
9	2	00906.0	1/4-20 x 1/2" Hex Head Bolt

1.3.11. Plumbing System Assembly (Auto-Fill)

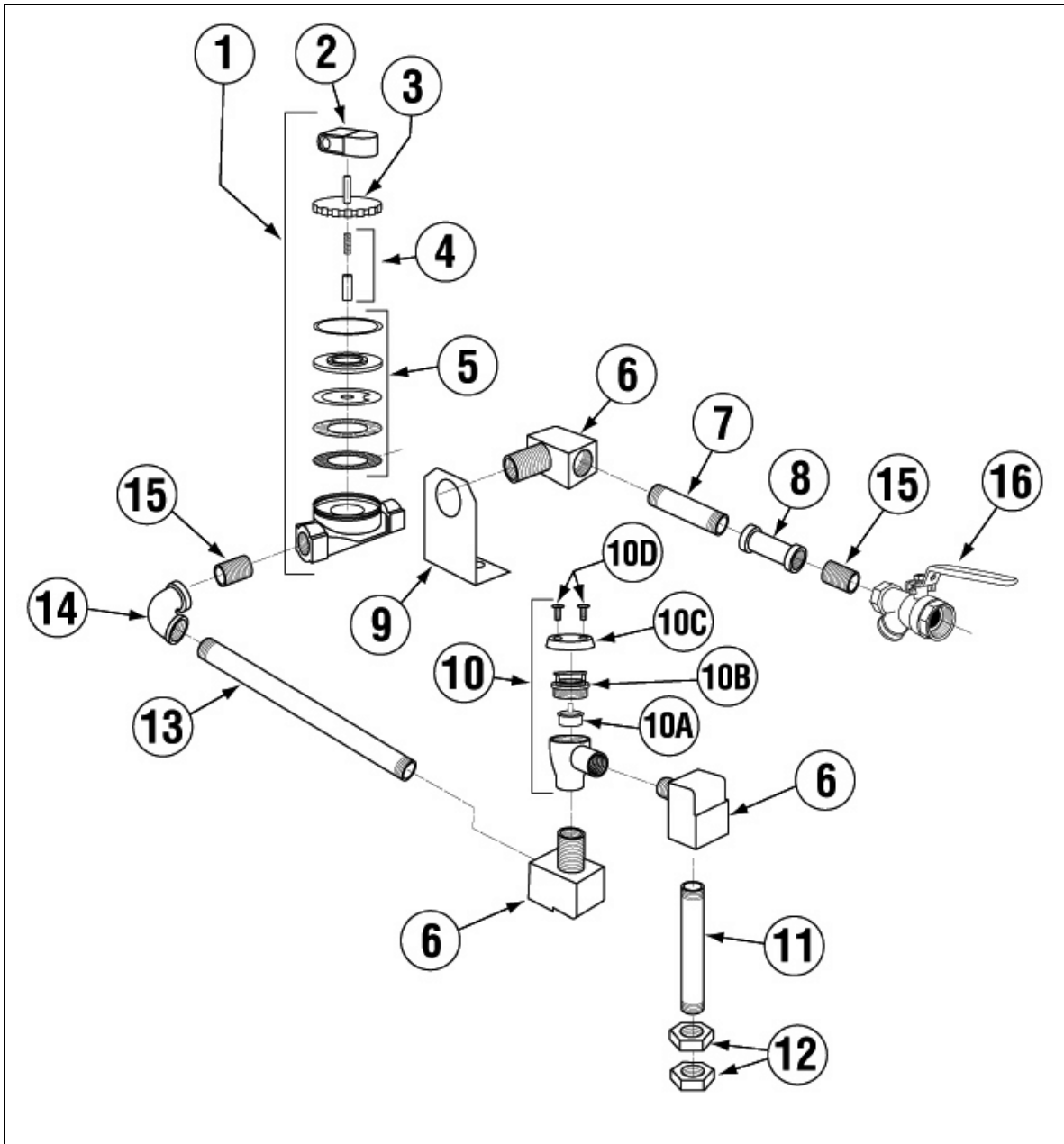

ITEM NO.	NO. REQ'D	P/N	DESCRIPTION
1	1	00705.05	3/4" Water Solenoid Valve 220V, JE*
2	1	00738.15	Water Solenoid Valve Coil, 220V, 1/2" & 3/4"
3	1	00705.20	3/4" Water Solenoid Valve Bonnet
4	1	00786.00	Water Solenoid Plunger with Spring
5	1	00706.00	3/4" Water Solenoid Valve Repair Kit
6	3	00704.00	3/4" 90° Street Elbow
7	1	00781.00	3/4" x 3-1/2" Nipple, Brass
8	1	00749.00	Coupling 3/4" Brass
9	1	01525.06	Plumbing Support Bracket
10	1	00710.50	3/4" Vacuum Breaker***

ITEM NO.	NO. REQ'D	P/N	DESCRIPTION
10A	1	00735.00	3/4" Vacuum Breaker Repair Kit
10B	1	00735.60	3/4" Vacuum Breaker Bonnet
10C	1	00739.50	Vacuum Breaker Cap
10D	2	00421.51	6-32 x 1/4" SS Panhead Screw
11	1	13612.00	3/4" x 5" Brass Nipple
12	2	13606.00	3/4" Jamb Nut, Brass
13	1	13634.06	3/4" x 8" Nipple, Brass
14	1	13633.00	3/4" 90° Elbow, F x F, Brass
15	1	00781.00	3/4" x 3-1/2" Nipple, Brass
16	1	13029.00	3/4" Strainer Ball Valves

Parts Manual

1.3.12. Plumbing System Assembly (Final Rinse)

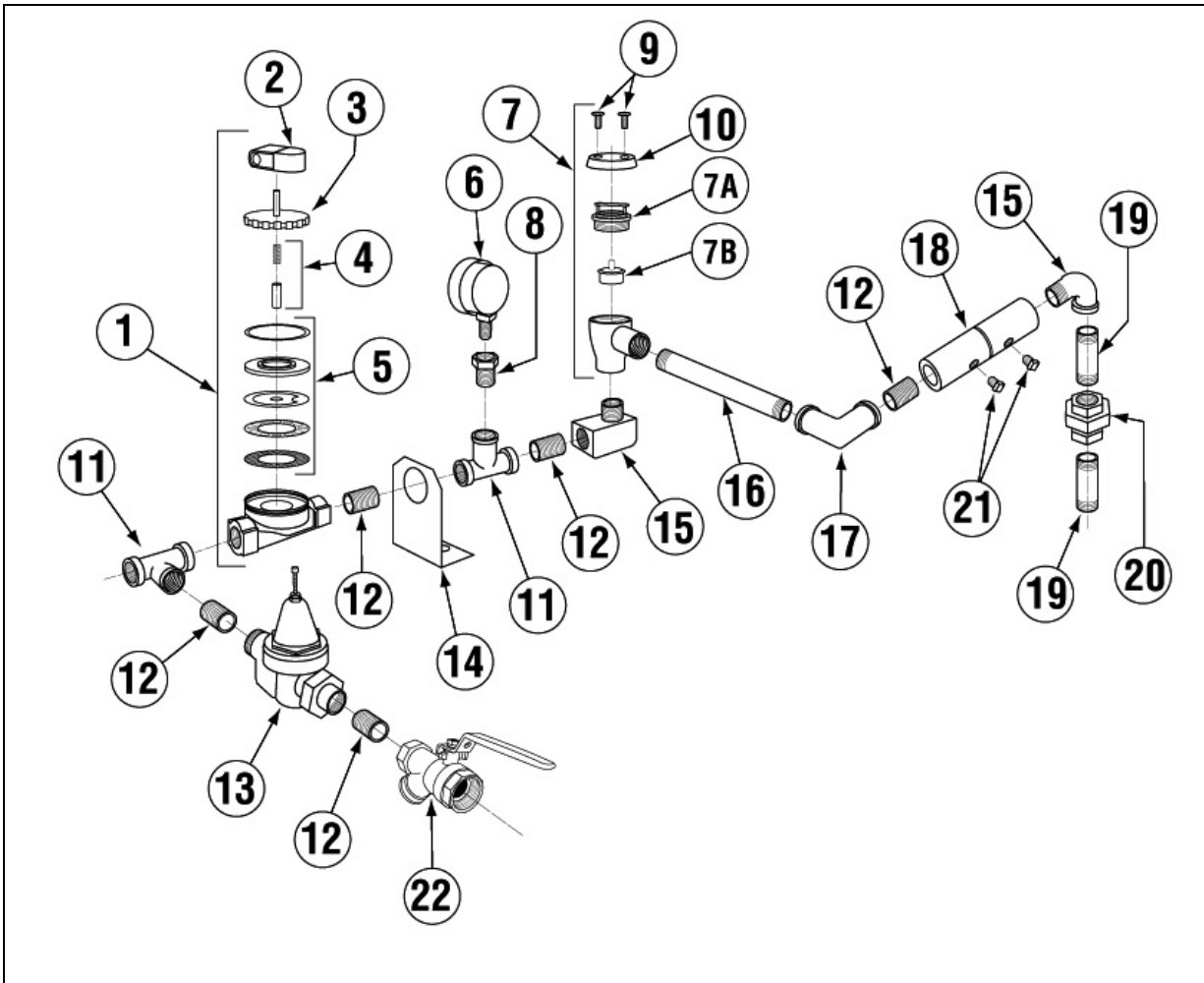

ITEM NO.	NO. REQ'D	P/N	DESCRIPTION
1	1	03603.15	1/2" Water Solenoid Valve 220V, JE*
2	1	00738.15	Water Solenoid Valve Coil, 220V, 3/4"
3	1	03603.20	1/2" Water Solenoid Valve Bonnet
4	1	00786.00	Water Solenoid Plunger with Spring
5	1	00707.00	1/2" Water Solenoid Valve Repair Kit
6	1	13605.00	Pressure Gauge
7	1	03624.00	1/2" Vacuum Breaker, Watts**
7A	1	03624.25	1/2" Vacuum Breaker Bonnet
7B	1	03623.00	1/2" Vacuum Breaker Repair Kit
8	2	04204.00	Compression Nut, 2.5"
9	2	00421.51	6-32 x 1/4" SS Panhead Screw
10	1	00739.50	Vacuum Breaker Cap

ITEM NO.	NO. REQ'D	P/N	DESCRIPTION
11	2	00743.10	1/2" Tee, F x F x F
12	4	03614.00	1/2" Close Nipple, Brass
13	1	13602.20	1/2" Pressure Regulator
14	1	01525.06	Plumbing Support Bracket
15	2	00745.00	1/2 90 Deg Street Elbow
16	1	00747.10	Nipple Brass 1/2 X 5"
17	1	41030.10	1/2" 90 Deg Ell F X F Brass
18	1	13669.20	CMA 44 Mixing Chamber ('07)
19	1	00780.00	Nipple Brass 1/2 X 2 1/2
20	1	13610.30	1/2" Union, SS
21	2	03232.00	1/8 Male Plug
22	1	41062.00	1/2" Strainer Ball Valves

Parts Manual

1.3.13. Plumbing System Assembly (Old Models)

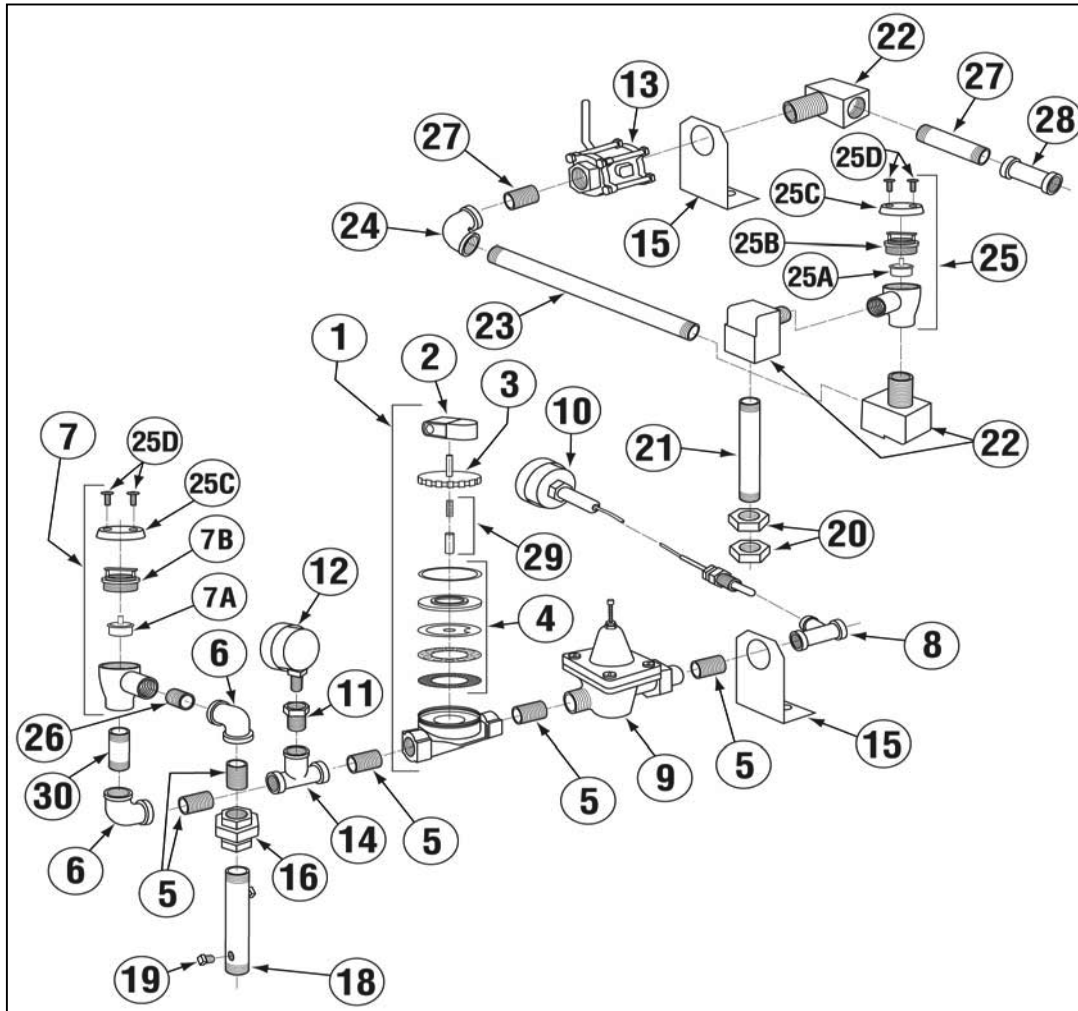

ITEM NO.	NO. REQ'D	P/N	DESCRIPTION
1	1	03603.15	1/2" Water Solenoid Valve 220V, JE*
2	1	00738.15	Water Solenoid Valve Coil, 220V, 1/2" & 3/4"
3	1	03603.20	1/2" Water Solenoid Valve Bonnet
4	1	00707.00	1/2" Water Solenoid Valve Repair Kit
5	4	03614.00	1/2" Close Nipple, Brass
6	2	41030.10	1/2" 90° Elbow, F x F, Brass
7	1	03624.00	1/2" Vacuum Breaker, Watts**
7A	1	03623.00	1/2" Vacuum Breaker Repair Kit
7B	1	03624.25	1/2" Vacuum Breaker Bonnet
8	1	00716.00	1/2" x 1/2" x 3/4" F x F x F Tee, Brass
9	1	13602.45	1/2" Pressure Regulator
10	1	03202.00	Thermometer (Capillary)
11	1	13604.00	1/2" x 1/4" Bushing
12	1	13605.00	Pressure Gauge
13	1	13028.00	3/4" Ball Valve, 3-piece
14	1	00743.10	1/2" Tee, F x F x F
15	2	01525.06	Plumbing Support Bracket
16	1	13610.30	1/2" Union, SS

*Includes Items 2, 3 and 4.
**Includes Items 7A, 7B, 25C and 25D.

ITEM NO.	NO. REQ'D	P/N	DESCRIPTION
17	1	00747.30	1/2" x 3" SS Nipple
18	1	13669.60	Mixing Chamber, 1/2" SS
19	2	03232.00	1/8" Male Plug
20	2	13606.00	3/4" Jamb Nut, Brass
21	1	13612.00	3/4" x 5" Brass Nipple
22	3	00704.00	3/4" 90° Street Elbow
23	1	13634.06	3/4" x 8" Nipple, Brass
24	1	13633.00	3/4" 90° Elbow, F x F, Brass
25	1	00710.50	3/4" Vacuum Breaker***
25A	1	00735.00	3/4" Vacuum Breaker Repair Kit
25B	1	00735.60	3/4" Vacuum Breaker Bonnet
25C	2	00739.50	Vacuum Breaker Cap
25D	4	00421.51	6-32 x 1/4" SS Panhead Screw
26	2	00742.00	1/2" x 2" Nipple, Brass
27	1	00781.00	3/4" x 3-1/2" Nipple, Brass
28	1	00749.00	Coupling 3/4" Brass
29	1	00786.00	Water Solenoid Plunger with Spring
30	1	00780.00	Nipple, Brass, 1/2" x 2-1/2"

***Includes Items 25A, 25B, 25C and 25D.

Parts Manual

1.3.9. Wash System Assembly

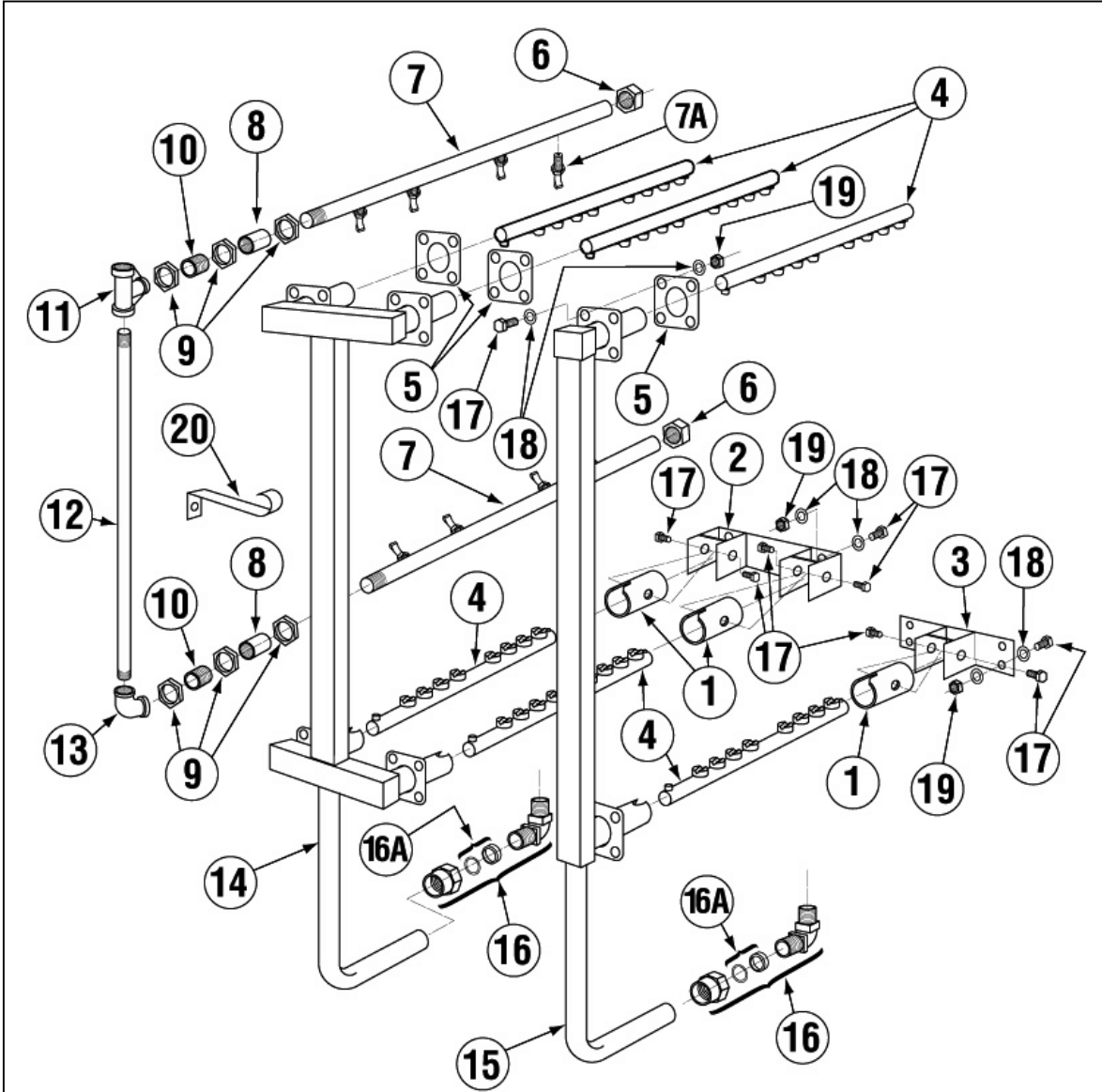

ITEM NO.	NO. REQ'D	P/N	DESCRIPTION
1	9	13305.06	Spray Arm End Cap
2	3	13327.06	Socket Bracket, Double
3	3	13327.26	Socket Bracket, Single
4	9	13303.16	Spay Arm
5	9	04306.10	Square Manifold Gasket
6	2	13310.00	1/2" Cap, Brass
7	2	13304.82	Final Rinse Spay Arm*
7A	8	13304.55	Final Rinse Spray Jets, SS
8	2	13618.00	1/2" Coupling
9	4	00721.20	1/2" Jamb Nut, Brass
10	3	13629.00	1/2" Close Nipple, SS

*Includes Item 7A

ITEM NO.	NO. REQ'D	P/N	DESCRIPTION
11	1	13630.00	1/2" F x F x F Tee, SS
12	1	13307.00	Final Rinse Tube, 23-1/2"
13	1	13628.00	1/2" 90° Elbow, F x F, SS
14	1	13301.12	Wash Manifold
15	1	13301.06	Pre-wash Manifold
16	2	00213.00	1" Ford Adapter, MIP x PJ Tube**
16A	2	00225.00	1" Compression Gasket
17	48	13305.40	Shoulder Bolt
18	96	00924.00	1/4" SS Washer
19	48	00912.00	1/4-20 Nylon Lock Nut
20	1	13304.53	Long Support Bracket

Parts Manual

1.3.10. Wash System assembly (Old Models)

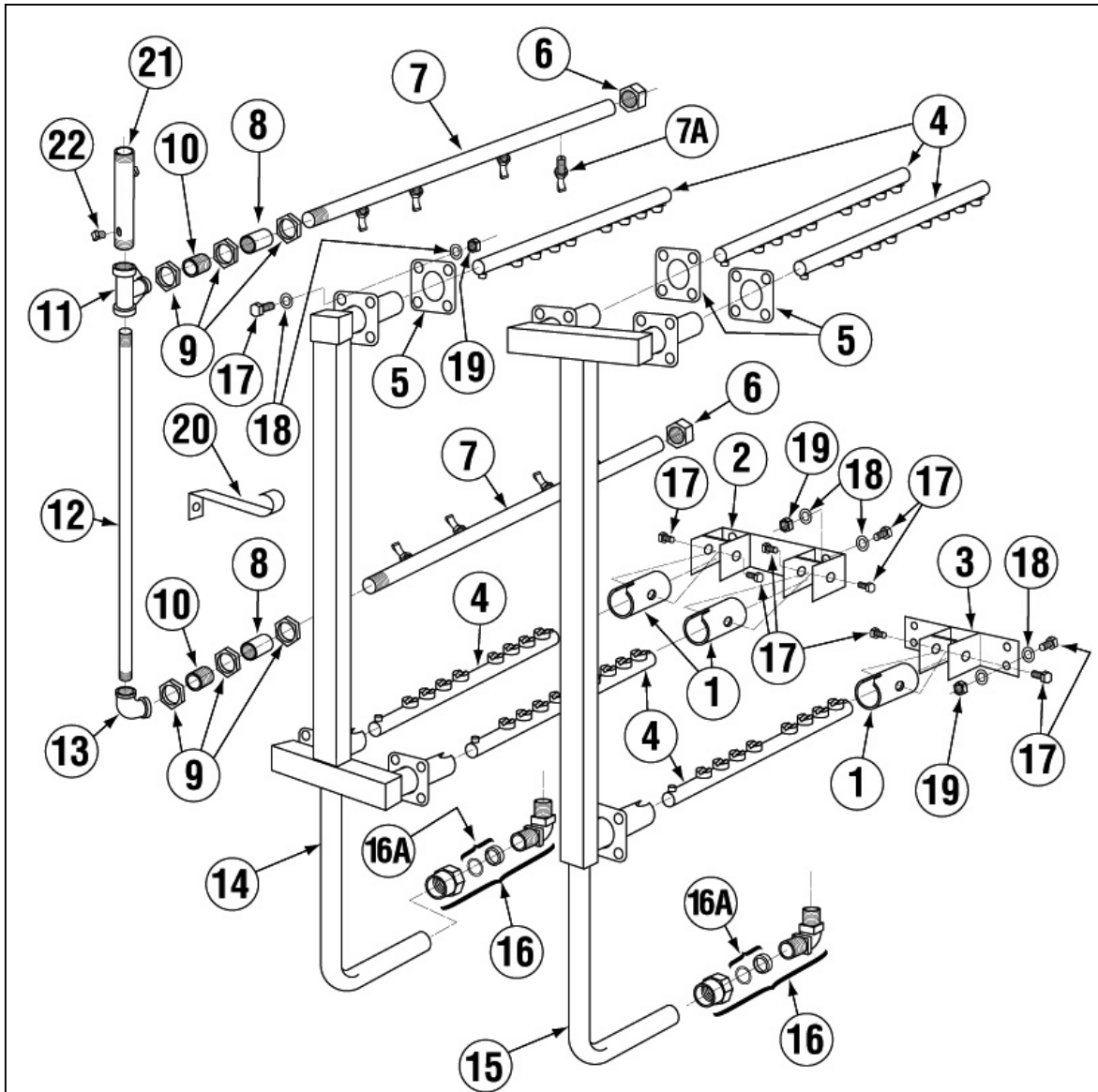

ITEM NO.	NO. REQ'D	P/N	DESCRIPTION
1	6	13305.06	Spray Arm End Cap
2	2	13327.06	Socket Bracket, Double
3	2	13327.26	Socket Bracket, Single
4	6	13303.16	Spay Arm
5	6	04306.10	Square Manifold Gasket
6	2	13310.00	1/2" Cap, Brass
7	2	13304.82	Final Rinse Spay Arm*
7A	8	13304.55	Final Rinse Spray Jets, SS
8	2	13618.00	1/2" Coupling
9	4	00721.20	1/2" Jamb Nut, Brass
10	3	13629.00	1/2" Close Nipple, SS
11	1	13630.00	1/2" F x F x F Tee, SS

*Includes Item 7A

ITEM NO.	NO. REQ'D	P/N	DESCRIPTION
12	1	13307.00	Final Rinse Tube, 23-1/2"
13	1	13628.00	1/2" 90° Elbow, F x F, SS
14	1	13301.26	Wash Manifold
15	1	13301.06	Pre-wash Manifold
16	2	00213.00	1" Ford Adapter, MIP x PJ Tube**
16A	2	00225.00	1" Compression Gasket
17	32	13305.40	Shoulder Bolt
18	64	00924.00	1/4" SS Washer
19	32	00912.00	1/4-20 Nylon Lock Nut
20	1	13304.53	Long Support Bracket
21	1	13669.60	Mixing Chamber, 1/2" SS
22	2	03232.00	1/8 Maze Plug

1.3.11. Rocker Arm Assembly

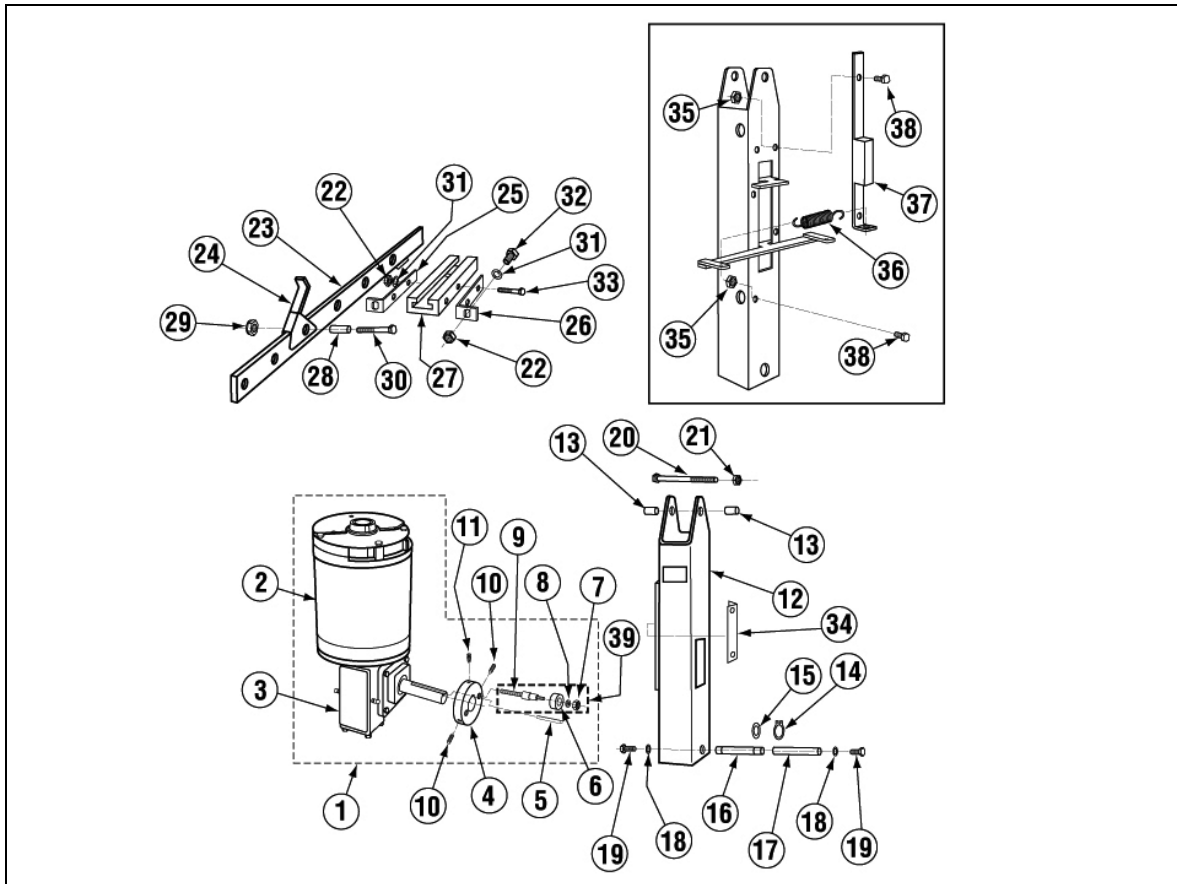

ITEM NO.	NO. REQ'D	P/N	DESCRIPTION
1	1	13570.20	Conveyor Drive Assy, 220V, 60Hz, 3Ph*
2	1	13501.85	Motor, 1/3HP, 220V, 60Hz, 3Ph
3	1	13504.35	Gear Reducer, Right to Left
		13504.30	Gear Reducer, Left to Right
4	1	13505.12	CMA 44 Drive Cam
5	1	13505.20	Keyway (Cam)
6	1	13507.20	Cam Bearing Only
7	1	13805.00	5/16-18 Nylon Insert Lock Nut
8	1	13507.11	Cam Bearing Shaft Spacer
9	1	13507.12	Cam Bearing Shaft
10	2	00935.22	1/4-28 x 1/2" Brass Tip Set Screw
11	1	13816.00	5/16-18 X 1/2 Socket Set Screw
12	1	13508.12	CMA 44 Rocker Arm
13	2	13513.10	Rocker Arm Spacer
14	2	13509.52	7/8" ID External Lock Ring
15	2	13509.53	1" ID Brass Washer
16	1	13509.12	CMA 44 Rocker Shaft Bearing
17	1	13510.10	Bearing Shaft
18	2	00922.00	1/4" Lock Star Washer
19	2	00914.00	1/4-20 x 3/4" Hex Head Bolt

ITEM NO.	NO. REQ'D	P/N	DESCRIPTION
20	1	13808.00	1/2-13 x 3-1/2"
21	1	13809.00	1/2-13 Nylon Lock Nut
22	1	00912.00	1/4-20 Nylon Lock Nut
23	1	13514.26	Conveyor Bar (8Dogs) (CMA-66)
24	8	13515.00	Conveyor Dog, SS
25	1	13514.82	Left Conveyor Bar Bracket
26	1	13514.84	Right Conveyor Bar Bracket
27	1	13521.50	Conveyor Bar Slide Bearing
28	10	13520.00	Conveyor Dog Bearing
29	5	13806.00	3/8" Nylon Lock Nut
30	5	13818.00	3/8-16 x 1-3/4" Hex Head Bolt
31	2	00924.00	1/4" SS Washer
32	2	00914.10	1/4-20 x 5/8" Hex Head Bolt
33	1	00903.00	1/4-20 x 1-3/4" Hex Head Bolt
34	1	13505.06	Cam Guide
35	4	00912.00	1/4-20 Nylon Lock Nut**
36	1	13508.70	Heavy Duty Clutch Spring
37	1	13508.26	Rack Saver Clutch Bar
38	4	00914.00	1/4-20 x 3/4" Hex Head Bolt**
39	1	13507.65	Cam Bearing Assy (12/07)

1.3.12. Rocker Arm Assembly (Old Models)

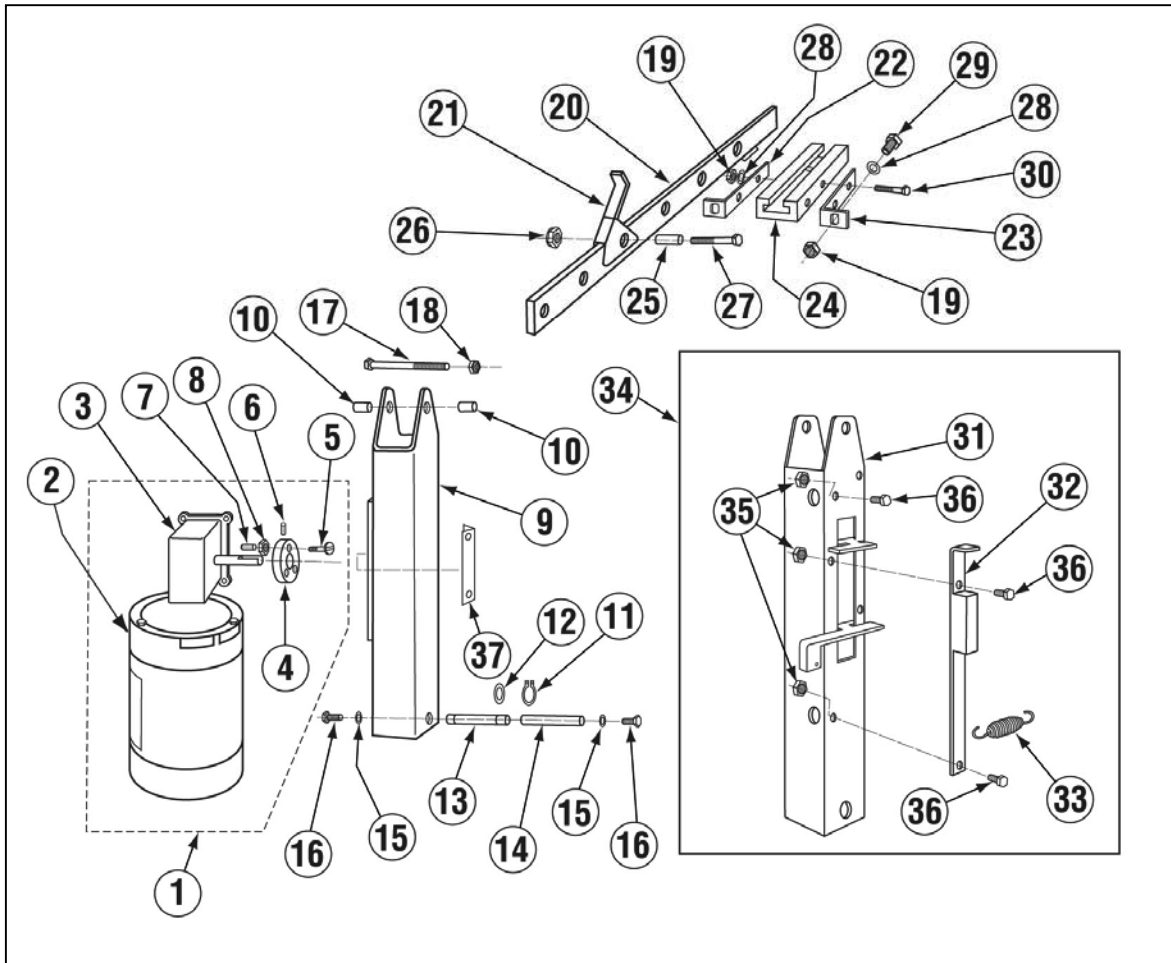

ITEM NO.	NO. REQ'D	P/N	DESCRIPTION
1	1	13570.20	Conveyor Drive Assy, 220V, 60Hz, 3Ph*
2	1	13501.85	Motor, 1/3HP, 220V, 60Hz, 3Ph
	3	13504.35	Gear Reducer, Right to Left
		13504.30	Gear Reducer, Left to Right
4	1	13505.10	Rocker Arm Cam
5	1	13507.60	Cam Bearing Assy
6	1	13816.00	5/16-18 x 1/2" Socket Set Screw
7	1	13505.20	Keyway Cam
8	1	13829.10	7/16-20 Hex Lock Jam Nut
9	1	13508.06	Rocker Arm
10	2	13513.10	Rocker Arm Spacer
11	2	13509.52	7/8" ID External Lock Ring
12	2	13509.53	1" ID Brass Washer
13	1	13509.51	Rocker Arm Shaft Bearing
14	1	13510.10	Bearing Shaft
15	2	00922.00	1/4" Lock Star Washer
16	2	00914.00	1/4-20 x 3/4" Hex Head Bolt
17	1	13808.00	1/2-13 x 3-1/2"
18	1	13809.00	1/2-13 Nylon Lock Nut

*Includes Items 2 through 8.

ITEM NO.	NO. REQ'D	P/N	DESCRIPTION
19	1	00912.00	1/4-20 Nylon Lock Nut
20	1	13514.26	Conveyor Bar (8 Dogs) (CMA-66)
21	8	13515.00	Conveyor Dog, SS
22	1	13514.82	Left Conveyor Bar Bracket
23	1	13514.84	Right Conveyor Bar Bracket
24	1	13521.50	Conveyor Bar Slide Bearing
25	10	13520.00	Conveyor Dog Bearing
26	5	13806.00	3/8" Nylon Lock Nut
27	5	13818.00	3/8-16 x 1-3/4" Hex Head Bolt
28	2	00924.00	1/4" SS Washer
29	2	00914.10	1/4-20 x 5/8" Hex Head Bolt
30	1	00903.00	1/4-20 x 1-3/4" Hex Head Bolt
31	1	13508.10	Rack Saver Rocker Arm
32	1	13508.26	Rack Saver Clutch Bar
33	1	13508.60	Swivel Hook Spring Assembly
34	1	13508.40	Complete Rack Saver Rocker Arm Assy
35	4	00912.00	1/4-20 Nylon Lock Nut**
36	4	00914.00	1/4-20 x 3/4" Hex Head Bolt**
37	1	13505.06	Cam Guide

**Number required is for Complete Rack Saver Rocker Arm Assembly only.

1.3.13. Trip Switch Assembly p/n 13475.06

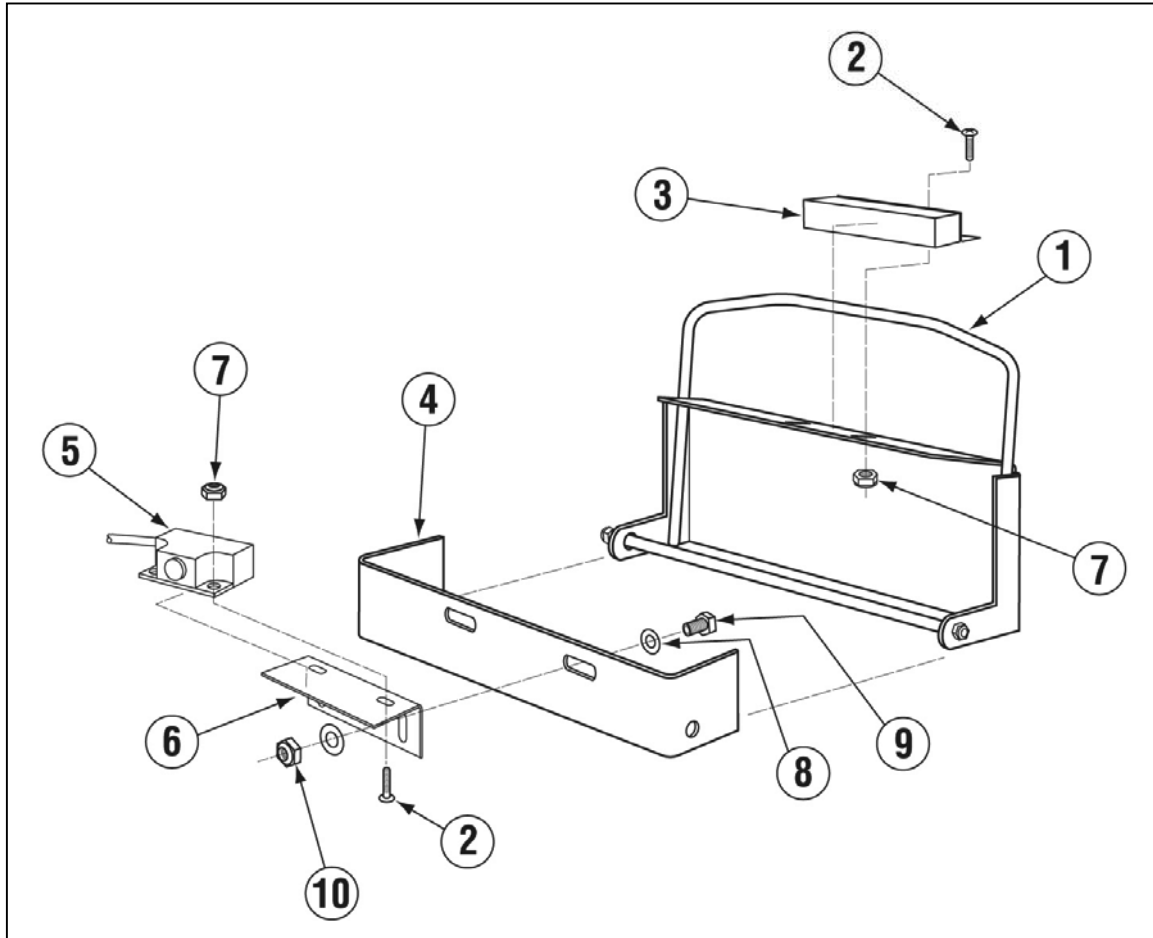

ITEM NO.	NO. REQ'D	P/N	DESCRIPTION
1	1	13408.61	Actuator Arm
2	4	00907.50	6-32 x 3/8" Pan Head Screw
3	1	00557.70	Reed Switch Magnet (SS)
4	1	13408.62	Actuator Bracket
5	1	00557.56	Reed Switch
6	1	13408.63	Reed Switch Bracket
7	4	00965.00	6-32 Nylon Lock Nut
8	4	00924.00	1/4" SS Washer
9	4	00906.00	1/4" -20 x 1/2" Hex Head Bolt
10	4	00912.00	1/4" - 20 Nylon Lock Nut

1.3.14. Paddle Switch Assembly (Old Models).

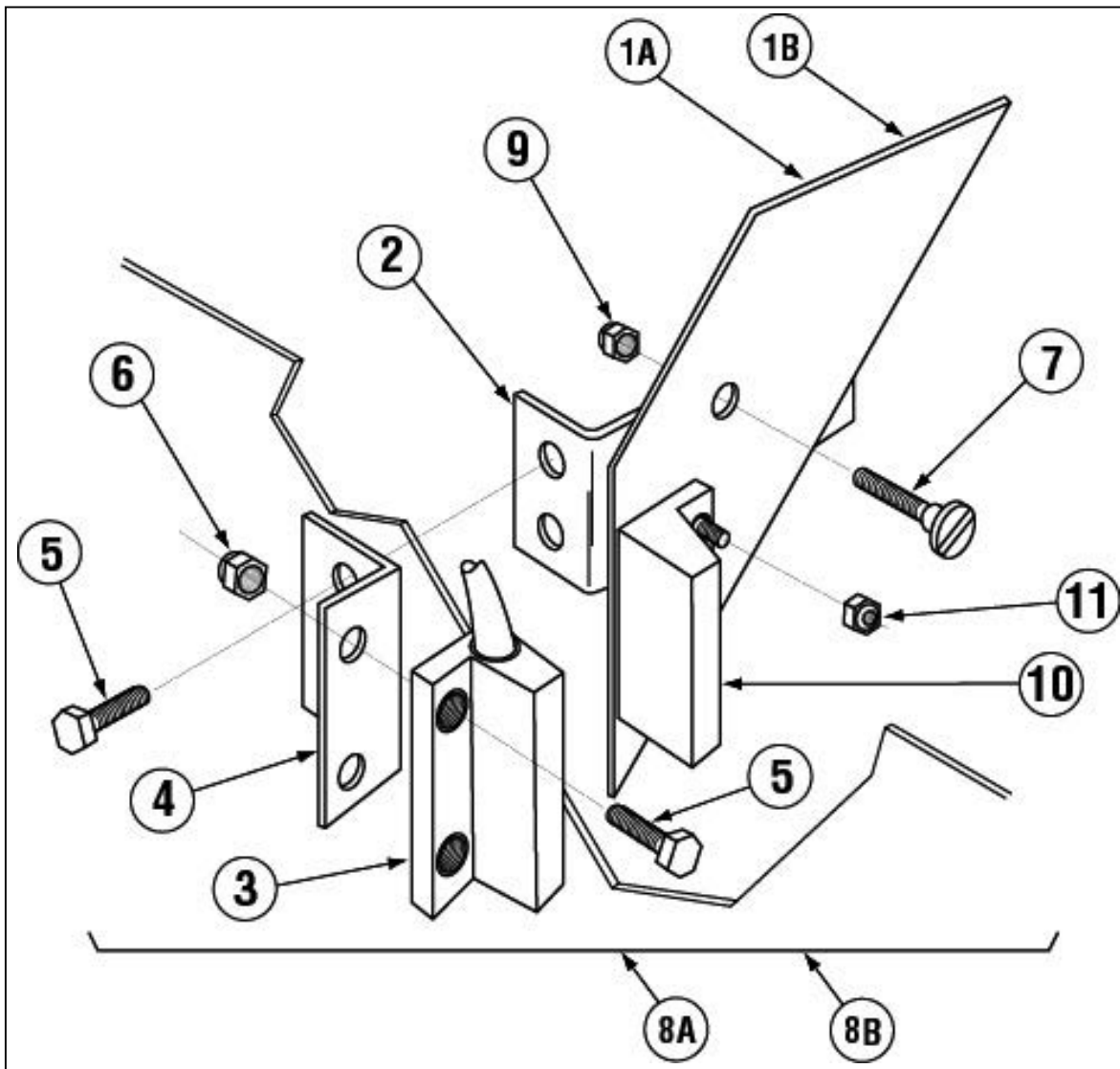

ITEM NO.	NO. REQ'D	P/N	DESCRIPTION
1A	1	13409.86	Paddle with Magnet, R-L
1B	1	13409.89	Paddle with Magnet, L-R
2	1	13409.87	Paddle Support Brackets
3	1	00557.56	Kynar Reed Switch
4	1	13409.30	PS Reed Switch Bracket
5	4	00914.00	1/4-20 x 3/4" Hex Head Bolt
6	4	00912.00	1/4-20 Nylon Lock Nut

ITEM NO.	NO. REQ'D	P/N	DESCRIPTION
7	1	00109.00	Shoulder Bolt
8A	1	13409.85	Paddle Switch Assembly, R-L
8B	1	13409.84	Paddle Switch Assembly, L-R
9	1	03801.00	10-32 Lock Nut
10	1	00557.70	Kynar Reed Switch Magnet
11	2	00927.00	8-32 Nylon Lock Nut

2. Table Limit Switch Instructions (P/N 13469.20)

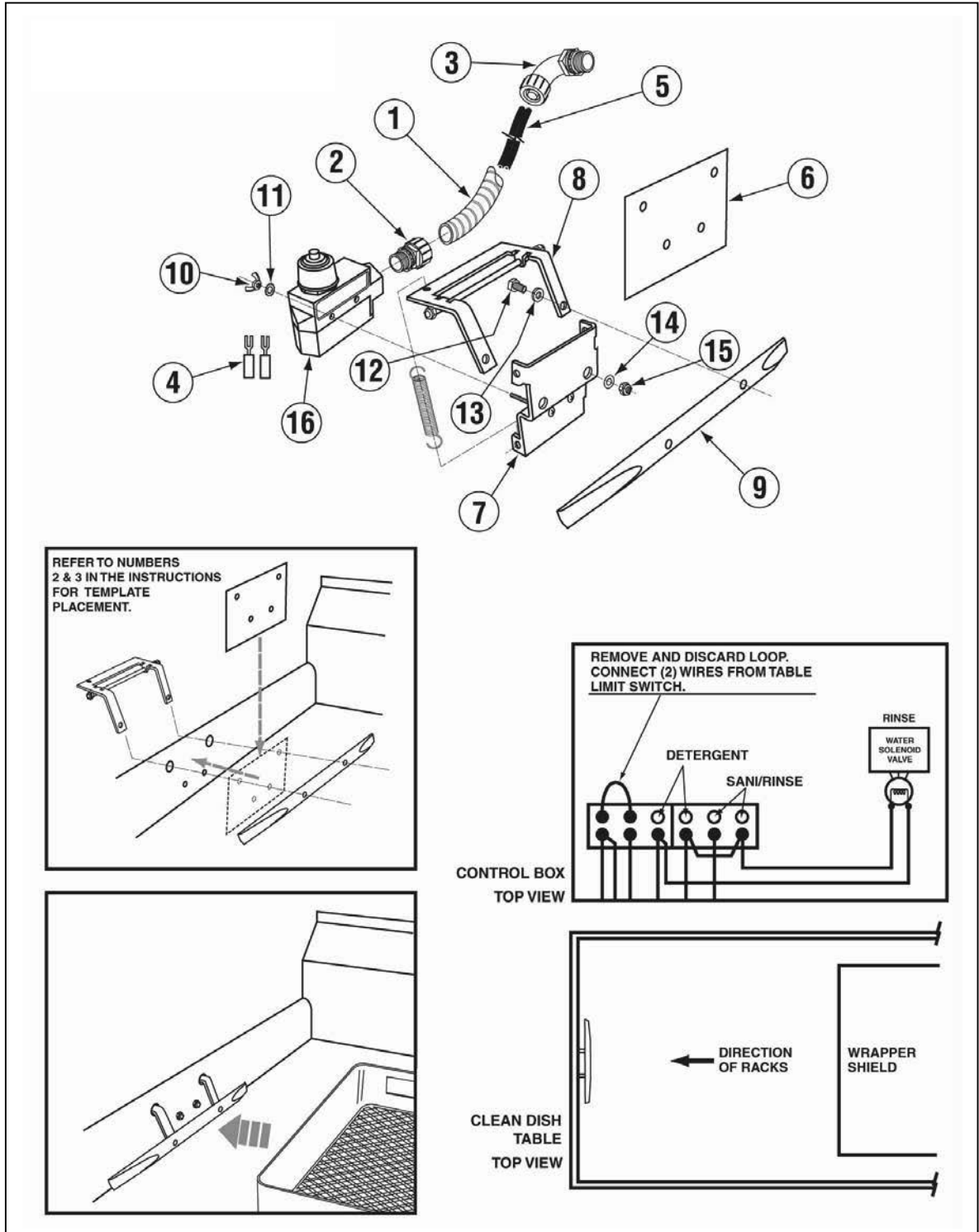

Parts Manual

	QTY	P/N	DESCRIPTION
1	12 FT	00400.00	Conduit 3/8 sealtite
2	1	00401.00	ST-3/8 straight connector
3	1	00402.00	ST-90 deg.3/8 connector
4	2	00666.00	Fork tongue connector
5	24 FT	00529.00	Wire 18 gauge black
6	1	13427.60	Template kit
7	1	13427.61	Mounting bracket
8	1	13427.62	Actuator
9	1	13427.63	Bumper
10	2	03817.00	6-32 wing nut
11	2	03814.10	Lock star washer
12	2	00914.10	1/4-20 x 5/8 hexhead bolt
13	2	00968.00	1/4 split lock washer
14	2	00924.00	1/4 ss washer
15	2	00912.00	1/4-20 nylon lock nut
16	1	13427.10	Limit switch

Instructions:

1. Determine the approximate centerline of the dish rack as it travels down the clean table.
2. Place the template from the template kit (6) with the lower edge resting on the table surface, against the end roll, and centered along the dish rack's line of travel. Mark the positions of the four holes and follow up with a center punch.
3. Drill a 1/8" hole through each position. The upper two holes then drilled out to 1/2".
4. Fasten the template with two bolts and nuts from the template kit (6). The lower holes then drilled out to 3/8".
5. From the outside, place the mounting bracket (7) halfway through the 3/8" lower holes on the table and the hinged actuator (8) through two 1/2" upper holes in the table.
6. Secure the bumper (9) by tightening the two bolts (12) with lock washers (13) through the two holes in the actuator.
7. Push the mounting bracket all the way into the holes in the table and tighten it with two lock nuts (15) and two washers (14).
8. Attach the conduit (1) between the control box and the table limit switch (16). Run two wires (5) through the conduit and conduit connectors (2,3), and attach one to the COMMON terminal on table limit switch, and the other to the normally OPEN terminal, using two fork tongue connectors (4). Secure the table limit switch on the mounting bracket with two wing nuts (10). Remove jumper from the optional table limit switch connection in the control box (see note 1 of the wiring diagram). Then, attach the other ends of the two wires to the terminal block (it does not matter which table limit switch wire you attach to either terminal because it is only a loop).

3. Drain Water Tempering Kit (Optional)

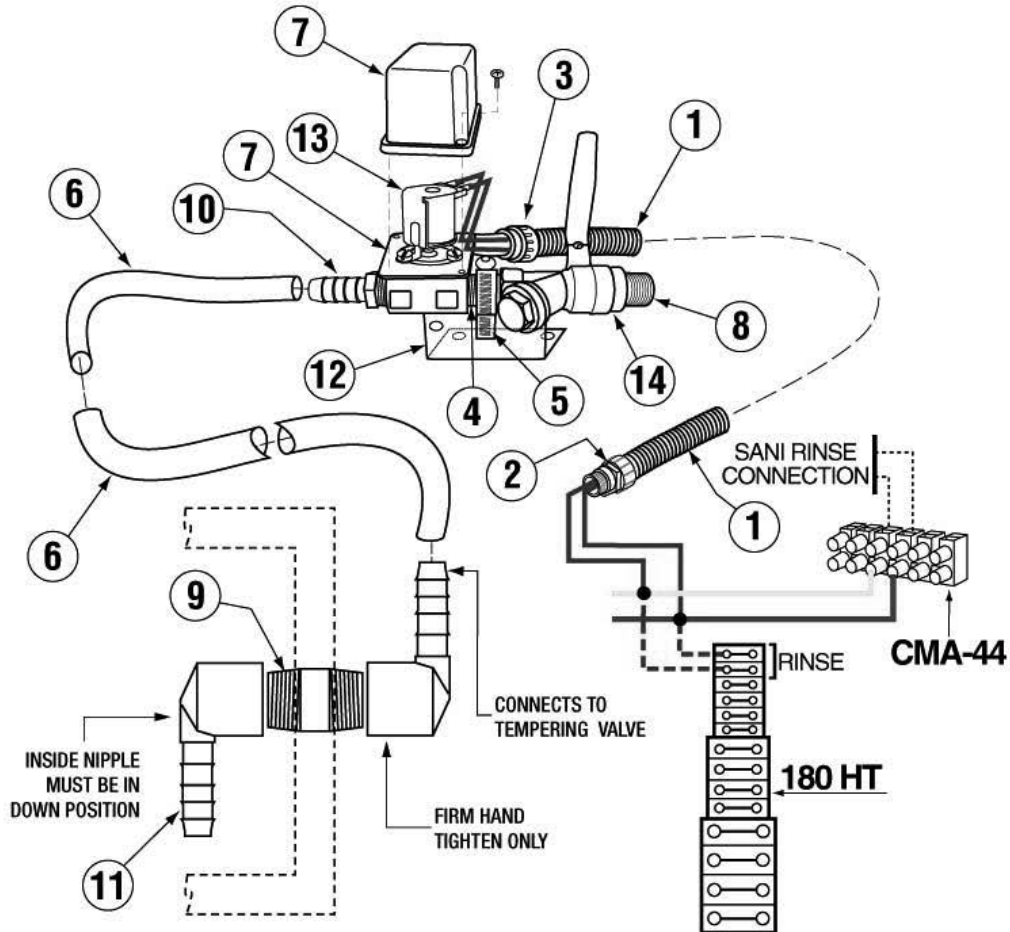

ITEM NO.	P/N	NO REQ'D	DESCRIPTION
1.	00400.00	2	CONDUIT 3/8" SEALTITE
2.	00401.00	1	ST-3/8" STRAIGHT CONNECTOR
3.	00402.00	1	ST-90 DEG 3/8" COCONNECTOR
4.	00742.00	1	NIPPLE BRASS 1/2X1-1/2"
5.	03101.00	1	HOSE CLAMP #16 1"
6.	03106.45	5	BRAIDED HOSE 1/2"
7.	03604.00	1	SS WATER SOLENOID VALVE 1/2"
8.	03614.00	1	NIPPLE BRASS 1/2"X CLOSE
9.	13472.00	1	NIPPLE PVC 1/2"X CLOSE
10.	13472.40	1	ADAPTER PVC 1/2" MALE X 1/2" BARB
11.	13472.50	2	ELBOW PVC 90 DEG F X BARB
12.	14508.50	1	PLUMBING BRACKET (180-UC)
13.	41015.75	1	SOLENOID VALVE COIL 220V
14.	41062.00	1	1/2" STRAINER BALL VALVE