

MODEL EST-FL

(FRONT LOADER)

INSTALLATION & OPERATION MANUAL

Rev.1.00



CMA DISHMACHINES
12700 KNOTT STREET
GARDEN GROVE
CALIFORNIA 92841

800-854-6417

FAX 714-895-2141

**CMA
MIZER®**
Registered Trademark



TABLE OF CONTENTS

Model EST-FL Front Loader

1. SPECIFICATIONS	2
1.1 EST-FL	2
2. GETTING STARTED	3
2.1. INTRODUCTION TO THE EST-FL FRONT LOADER	3
2.2. RECEIVING AND INSTALLATION	4
2.2.1. <i>Electrical</i>	4
2.2.2. <i>Plumbing</i>	4
2.2.3. <i>Connecting the Scrap Accumulator and Drain</i>	5
3. OPERATION	6
3.1. INITIAL SETUP	6
3.2. EST-FL FRONT LOADER OPERATIONAL CYCLE	7
3.3. (OPTIONAL) HOT-WATER ASSURANCE STORAGE TANK	9
3.4. STARTUP PROCEDURES.....	10
3.5. QUICK SERVICE TROUBLE SHOOTING GUIDE	11
4. ADDENDUM FOR MACHINES INSTALLED IN THE CITY OF CHICAGO	12
5. ELECTRICAL DIAGRAM	13

1. Specifications

1.1 EST-FL	USA	METRIC
WATER CONSUMPTION		
PER RACK	1.09 GAL.	(4.12 L)
PER HOUR	43.6 GPH.	(165LPH)
OPERATING CYCLE		
WASH TIME-SEC.	53	53
RINSE TIME-SEC.	30	30
DWELL TIME-SEC.	7	7
TOTAL CYCLE	90 SEC.	90 SEC.
OPERATING CAPACITY		
RACKS PER HOUR	40	40
WASH TANK CAPACITY	1.09 GAL.	(4.12 L)
PUMP CAPACITY	52 GPM	(196.8 LPM)
WATER REQUIREMENTS		
REQUIRED MINIMUM TEMP.	120°F	(49°C)
RECOMMENDED TEMP.	140°F	(60°C)
WATER INLET	½"	1.27 cm
DRAIN CONNECTION	2"	5.1 cm
DIMENSIONS		
DEPTH	25 ¼"	(65.405 cm)
WIDTH	25 ¼"	(65.405 cm)
HEIGHT	55-56"	(140-142 cm)
MAX CLEARANCE FOR DISHES	16"	(40.6 cm)
STRANDARD RACKS	19 ¾" x 19 ¾"	(50 x 50 cm)
ELECTRICAL RATING		
(Total minimum Ampacity)	VOLTS	AMPS
	(60-Hz)	
	115	16
WASH PUMP MOTOR	1 HP	
SHIPPING WEIGHT		
APPROXIMATE	273#	(124 kg)

Note: The required flowing water pressure to the dishwasher is 15-65 PSIG. If pressures higher than 65 PSIG are present, a pressure regulating valve must be installed in the water line to the dishmachine (by others). If flowing pressure is lower than 15 psi, improper machine operation may result.

Getting Started

2. Getting Started

2.1. Introduction to the EST-FL Front Loader

The EST-FL low temperature Front Loader Dishmachine is safe, economical and easy to operate with its "Auto Start/Stop", and it uses only 1.09 gallons of water per cycle. The EST-FL Front Loader Dishmachines top mounted controls houses built-in chemical pumps and a delimiting system that assures proper chemical usage. Its integrated scrap tray prevents food soil from entering the drain system. The EST-FL can be run at a rate of 40 racks/160 covers per hour and its all stainless steel construction assures longevity.

The EST-FL Front Loader; features an optional fully intergraded hot-water assurance storage tank, to insure consistent water temperature is always being supplied to the dishmachine. *The attributes of this dishmachine are always taken into consideration by our well-trained sales representatives prior to the order being placed.*

This manual is structured to provide a complete reference guide to the EST-FL Front Loader Dishmachine. It is presented in a manner that all levels of users will be able to comprehend and use as an effective tool in supporting the operation and maintenance of the dishmachine. The function of the dishmachine itself is mostly automatic and takes little training to put into operation. The Operation section also includes diagnostic considerations (troubleshooting) for the dishmachine when problems occur.

The first section explains how the dishmachine is packaged and what to look for when receiving the machine. After unpacking the dishmachine, this manual explains how to install and set up the dishmachine for use. Requirements are given for plumbing, wiring, and space considerations.

Guidance is also given for installation to ensure that the machine will be able to run at optimum efficiency. The Operation section of the manual may be used for instruction and procedures when required. Parts Manual and Electrical Diagram—have the parts lists with exploded view drawings and the wiring diagram for the dishmachine.

CMA Dishmachines warrants the workmanship of the dishmachine. We are committed to providing the best dishmachines and customer service in the warewashing industry and your feedback is welcome.

DISCLAIMERS

CMA Dishmachines expressly disclaims any and all warranties, express or implied, relating to the installation of any and all CMA equipment *that is installed* by chemical dealers, contracted servicers or third party servicers to CMA equipment. If the installation instructions are not followed exactly (to the letter), or, if any person or company conducting the installation of the CMA equipment, revise the installation procedures or alter the instructions in any manner, the CMA warranty becomes void. If, due to the improper installation of CMA equipment, this equipment ceases to operate properly or affects other parts of the CMA dishwashing equipment, in that the other parts become defective, the CMA warranty becomes void. CMA will not be liable or responsible or warrant CMA equipment, due to improper installation of any CMA model dishwasher.

CMA Dishmachines does not endorse "Tankless On-Demand" water heaters for use on CMA Dishmachine products. On most applications, the volume of hot water required for commercial dishmachines exceeds the capacity of these types of heating sources. You will find that most, if not all, commercial dishmachines have been programmed with auto-filling features that require quick filling, with a designated limited time.

CMA Dishmachines does endorse, and highly recommends, the standard "tank" style hot-water heaters, sized properly to handle each particular facility with their water heating requirements. A "tank" style water heater stores and supplies a large capacity of preheated water before providing hot water to the dishmachine. To meet required health codes, there must be a reliable and consistent flow of adequate hot water supplied to the dishmachine. If the facilities' "tank" style water heater is marginal in size, the option on-board hot-water assurance storage tank can be used, which can be fully intergraded into the footprint of the dishwasher



2.2. Receiving and Installation

The dishmachine is shipped from the factory in a corrugated box on a wooden pallet. The installation guidelines give a systematic procedure for setting up the machine. Start by removing the dishmachine from the box, and remove all the packaging materials. Unwrap the machine, and check for the following components:

- Inside the wash tank is a plastic bag with one control box key and a cam timer wrench.
- Tube stiffeners must be used to prevent the feed tubes from curling inside the chemical pail and sucking air. These are located on the outside of the machine with the chemical tubing already installed into the stiffeners. The ends of the chemical tubing have been flared so that the tubing will not pull out of the stiffener. Red is for detergent, white for sanitizer, and blue for rinse aid.

2.2.1. Electrical*

Prior to installation make sure the electrical supply is compatible with the specifications on the machines data plate.

The EST-FL Dishmachine must be hard wired directly to a dedicated 115 VAC, 60Hz circuit equipped with proper circuit protection. The main power switch is at the top-right side of the control box.



DO NOT USE POWER CORD OR GFI OUTLET

This unit **MUST BE** hard-wired to a dedicated appropriately size circuit breaker.

WARNING: *Electrical and grounding connections must comply with the applicable portions of the National Electrical Code and/or other local electrical codes.*

Note: For supply connections, use copper wire only rated at 90 degree C minimum.

2.2.2. Plumbing*

The water supply connection is made with a 1/2" hot water line to the water supply inlet on the top of the dishmachine. The water supplied to the machine is recommended to be 140° F. The time necessary to deliver water to the machine is controlled by the number four cam.

The EST-FL Front Loader Dishmachine has a 2" drain. The following section explains how to connect the drain.

* **Electrical and plumbing connections must be made by a qualified person who will comply with all available Federal, State, and Local Health, Electrical, Plumbing and Safety codes**

Getting Started

Notice to Plumber: The plumber connecting this machine is responsible for making certain that the water lines are THOROUGHLY FLUSHED OUT BEFORE connecting to the dishmachine

CMA recommends utilizing a water softening system to maintain water hardness measurements of 3.5 gpg (grains per gallon) or less. This will assure maximum results and optimum operation of the dishmachine.

*Note: high iron levels in the water supply can cause staining and may require an iron filter. High chlorine levels in the water supply can cause pitting and may require a chloride removal system. If an inspection of the dishwasher or booster heater reveals lime buildup after the equipment has been in service, water treatment is recommended. If water softener is already in place, ensure there is a sufficient level of salt.**

2.2.3. Connecting the Scrap Accumulator and Drain

The scrap accumulator is designed to perform two basic functions:

1. It allows a method to discharge all the heavy solids out of the machine with each wash cycle.
2. It provides accumulation capacity to allow draining the contents of one cycle regardless of the discharge rate of the existing drain.

The drainpipe is connected to the scrap accumulator drain using a 2" no-hub connector as shown in Figure 2.2.3 below.

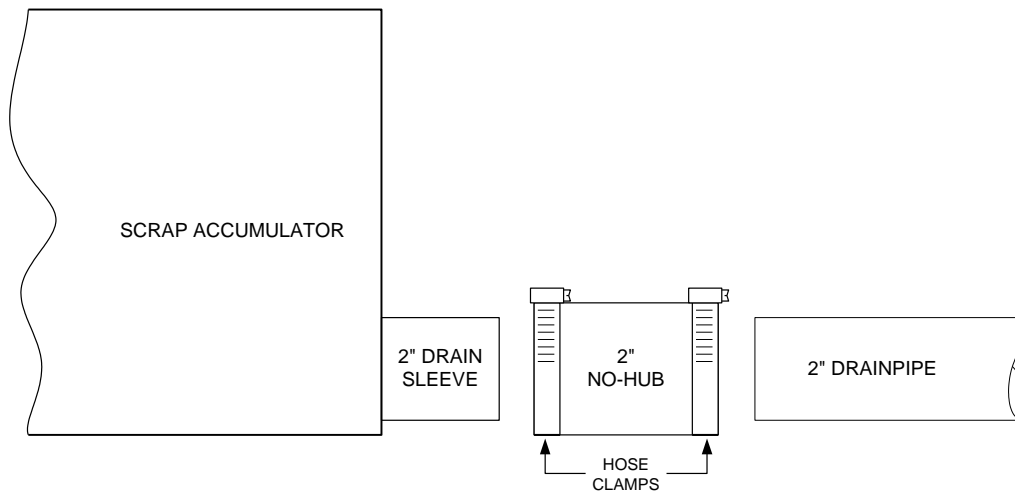

Figure 2.2.3

* The de-liming agents used to de-scale a commercial dishwasher, are highly caustic and de-liming should be done by a qualified chemical specialist.

3. Operation

3.1. Initial Setup*

The CMA EST-FL Front Loader is equipped with switches to prime the peristaltic pumps at anytime when the master power switch on the back of the control box is "ON".

Following completion of the installation, always fill the machine with water before starting the machine.

1. With the power switch "ON" press and hold the Fill switch until the water overflows into the wash scrap accumulator.
2. Check the chemical lines to the chemical containers.
 - a. Red: Detergent line.
 - b. Blue: Rinse Aid line.
 - c. Clear/White: Sanitizer line.
3. Individually activating the prime switches for the three chemical pumps until each product is discharging into the dishwasher.

*(The chemicals **must** be programmed by a qualified chemical specialist)*

Note: Use only commercial-grade detergents and rinse aids recommended by your chemical professional. Do not use detergents and rinse aids formulated for residential dishwashers.

Low Temperatures chemical-sanitizing dishmachines must not exceed 6% sodium hypochlorite solution (bleach) as the sanitizing agent. Higher levels may damage stainless or components.

Follow the directions precisely that are on the litmus paper vial and test the water on the surface of the bottom of the glasses. Concentration should be 50 p.p.m. minimum to 100 p.p.m. maximum. If concentration is incorrect contact your chemical supplier.

4. To start the dishmachine, close the door press and hold the start-switch for 2 to 3 seconds or until the cycle begins. The machine will run through its cycle.
5. Operate the machine one cycle and watch to ensure that the chemicals are delivered and stop during the cycle. Remember: red tube - detergent: blue tube – rinse aid: and clear/white tube - sanitizer. Check temperature at the end of the cycle for 140°F, 60°C.

The amount of product delivered by each cam is controlled by adjusting the cam's opening. When the micro switch rides down into the cam the peristaltic pump motor begins to rotate. It will continue to rotate until it rides up out of the groove.

Therefore, to extend the amount of product delivered to the machine, open the groove; to reduce the amount of product delivered to the machine, close the groove. The cams are slip fit and a cam adjustment wrench is provided.

CAUTION: The motors on the new peristaltic pumps may be stalled by excessive tightening of the cover plate screws. If a peristaltic pump does not turn when the micro switch is activated, loosen the screws on the cover plate.

Technical personnel are available during normal business hours at CMA Headquarters should you, as an installer, have any questions please call CMA Tech Support at: **800-854-6417** for assistance.

Operation

3.2. EST-FL Front Loader Operational Cycle*

The EST-FL Operational Cycle has a total cycle time of 90 seconds. The Timing Diagram and the steps listed below detail the individual functions that are executed during each Operational Cycle.

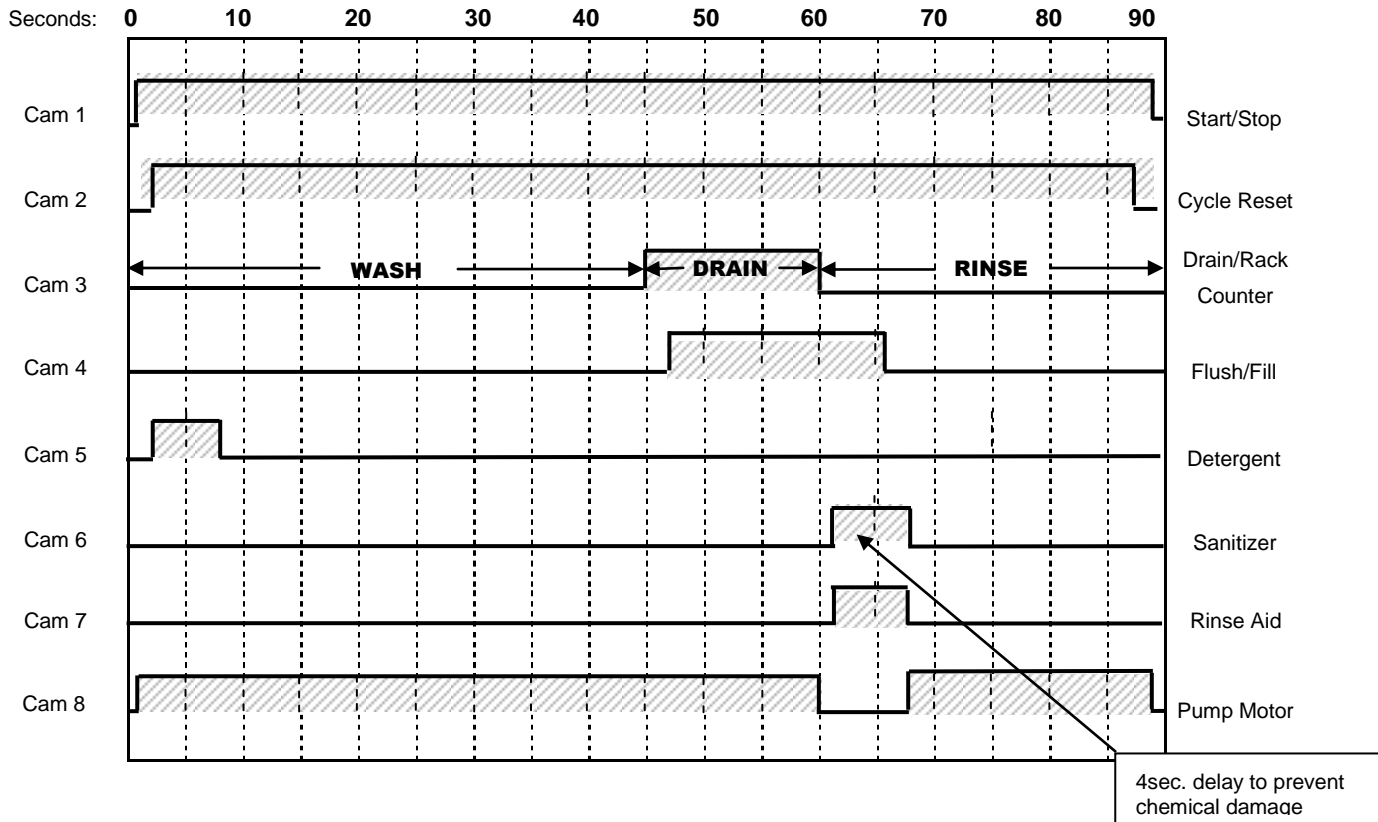

1. With the machine powered up, the door closed the dishwasher will begin a cycle.
 - a) When the Start switch is pressed the timer assembly motor is energized through the normally closed contact of the Start/Stop Relay.
 - b) Within a couple of seconds cams 1 and 2 close their respective switches. Cam switch 1 (Start/Stop) maintains power to the timer assembly motor throughout the 90-second cycle. Cam switch 2 (Cycle Reset) energizes the Start/Stop Relay.
 - c) The Start/Stop Relay, once it is energized by cam switch 2, is held in by its own normally open contact for as long as the doors remain closed.

* "S" series same otherwise noted

2. Cam switch 8 controls the pump motor. The pump motor comes ON at the beginning of the operational cycle and continues to run until the end of the drain function (controlled by cam switch 3), at which time it turns off for about eight seconds allowing time for the machine to refill enough to avoid running the pump dry before the pump motor restarts and runs to the completion of the operational cycle.

The pump motor runs the pump for the 45-second wash cycle, then pumps the water out through the drain, turns off for about 8 seconds (allowing the machine to refill with clean rinse water) and then runs the pump for the 30-second rinse cycle.

3. Cam switch 3 controls the drain function. At the end of the 45-second wash cycle, cam switch 3 energizes the drain solenoid allowing the wash water out of the machine. Cam switch 3 also increments the rack counter by one each cycle.
4. Cam switch 4 controls the water solenoid valve on the water supply to flush and fill the machine. At the end of the wash cycle the drain solenoid valve is open and drain begins, the pump motor continues to run. About the middle of the drain cycle, Cam 4 opens the fill solenoid valve and the flush function begins flushing residual detergent. At the end of drain cycle, drain solenoid valve closes and the pump motor is stopped—the machine begins to fill for the rinse cycle. Once the machine has refilled sufficiently, the pump motor restarts carrying out the rinse portion of the cycle as the filling of the wash tank completes. This can be adjusted as necessary for water pressure situation.
5. Cam switch 5 controls the detergent pump and turns ON about 5 seconds after the operational cycle is started and runs for a few seconds to provide sufficient detergent for the wash cycle. This cam can be adjusted as necessary for proper detergent dosage.
6. Cam switches 6 and 7 control the sanitizer and rinse pumps respectively. They turn ON at the beginning of the rinse cycle and run for a few seconds to provide sufficient sanitizer and rinse aid for the rinse cycle. These cams can be adjusted as necessary for proper chemical dosage.
7. At the end of the cycle cam switches 1 and 2 open (de-energize) stopping the cycle. The Start/Stop relay is held energized by its normally open contact until the doors are opened. Opening the doors de-energizes the Start/Stop Relay, which will then cause a new cycle to start when the doors are once again closed.

Note: *Press and holding the START switch on for a couple of seconds will start a cycle.*

The Water and Chemicals to the dishmachine must be programmed by a qualified chemical specialist. Contact your local Chemical Supplier or Equipment Dealer for assistance.

3.3. (Optional) Hot-Water Assurance Storage Tank

The Optional Fully Integrated Hot-Water Assurance Storage Tank will **not** require its' own power supply. The unit has been designed with a 115 volt, 1500 watt element which will only be active when the dishwasher is not in operation.

This will assure consistent and continuous water temperature is being supplied to the dishmachine at all times. This unit can be ordered to be fully installed, from the factory, if necessary it can be field installed by a qualified field service technician.

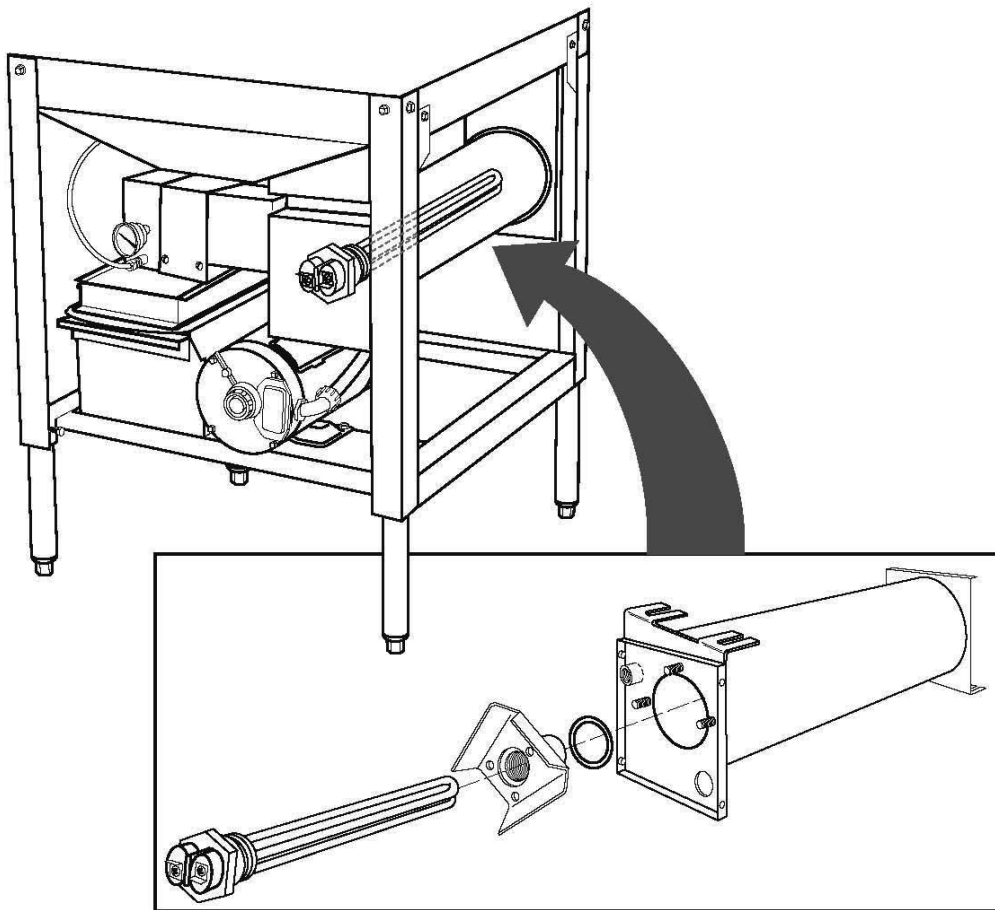

Note: The storage-Tank is shipped on the dishmachine empty to prevent damage from freezing. When the dishmachine is powered up for the first time, the storage tank must be filled with water by pressing and holding fill switch; this will prevent heating element from being damaged.

Note: Plumbing connections must be made by a qualified service company who will comply with all available Federal, State, and Local Health, Plumbing and Safety codes.

3.4. Startup Procedures

Please follow the instructions given here before each shift to assure trouble free operation.

2. Drain the water if it is cold, by pressing and holding the drain switch until all the water is completely drained from the dishwasher.
3. Check the internal drain screen if necessary, remove it from the machine and clean it out. After cleaning, reinstall it properly back into the sump.
4. Check the wash arm spray tips. If they are clogged, clean with soft bristle brush and a toothpick, and rinse well in sink. Reinstall the wash arms.
5. Press and hold the Fill switch until the water overflows into the wash scrap accumulator.
6. Once a proper water level is established, check the temperature of the water (it should be between 120°F 66°C and 140°F, 77°C).
7. Insert the tray of dishes into the machine and close the doors. The press and hold the start-switch for 2 to 3 seconds while the wash-cycle is started.
8. After the machine stops, lower the door, slide the dish-rack out onto the door and allow the contents to dry, before stacking.

When the door is lowered during a cycle, the machine will automatically stop running.

The EST-FL Front Loader will run through the wash and rinse cycles automatically feeding the proper chemicals and then turn itself off.

(The Water and Chemicals to the dishwasher must be programmed by a qualified chemical specialist)

In an emergency you can turn off the machine by turning off the master switch located on the back of the control box.

3.5. Quick service trouble shooting guide

MODELS: EST-FL Front Loader

TECHNICAL ISSUE	Cause	Solution
Machine starts while doors are open	Faulty magnetic door switch	Replace the switch, P/N 00556.10
	Faulty start/fill switch	Replace the switch, P/N 03470.01
Continuous cycles	Faulty #1 micro switch (start/stop)	Replace micro switch, P/N 00411.00
	Faulty start/fill switch	Replace micro switch, P/N 00411.00
	Faulty door switch	Replace the switch, P/N 00556.10
Wash motor runs continuously	Delimer switch in wrong position	Switch to <i>NORMAL</i> position
	Faulty delime switch	Replace the switch, P/N 00475.00
	Faulty motor contactor	Replace contactor, P/N 00404.82
Sanitizer pump does not run	Delimer switch on wrong position	Switch to <i>NORMAL</i> position
	Faulty delimer switch	Replace the switch, P/N 00475.00
	Faulty # 6 micro switch	Replace micro switch, P/N 411.00
	Faulty sanitizer pump motor	Replace the motor, P/N 00416.00
Drain valve does not operate	Broken Spring	Replace spring, P/N 00105.82
	Faulty #3 Micro switch	Replace micro switch, P/N 00411.00
	Faulty drain motor	Replace drain motor, P/N 00104.82
Machine does not fill	Faulty #4 micro switch (Fill)	Replace micro switch, P/N 00411.00
	Debris inside water solenoid valve	Clean valve replace diaphragm kit, P/N 00707.00
	Faulty start/fill switch	Replace the switch, P/N 03470.01
	Drain not closing	check function of drain sys.
	Faulty water solenoid coil/valve	Replace coil/valve, P/N 00738.10 or 03603.10
Water leaks out of vacuum breaker	Faulty check valve	Replace valve, P/N 00718.00
	Low incoming water pressure	Increase water pressure to 20 psi
	Faulty vacuum breaker kit	Replace vac. Brkr kit, P/N 03623.00
Machine only runs when start/fill switch is depressed	Faulty #1 micro switch (start/stop)	Replace micro switch, P/N 00411.00
	Faulty magnetic door switch	Replace door switch, P/N 00556.10
Will not start/ nothing works	Wall breaker tripped	Reset breaker
	Master on/off switch faulty or in off position	Reset or replace switch, P/N 00471.10
Runs, but none of the other functions engage	Faulty #2 Micro switch (cycle reset)	Replace micro switch, P/N 411.00
	Faulty ice cube relay (yellow relay)	Replace relay, P/N 00636.00



4. Addendum for Machines Installed in the City of Chicago

"All food dispensing establishments using chlorine or other approved chemical sanitizers shall, at all times, maintain an adequate testing device."

"Dishes and other eating and drinking utensils to be washed in a dishwashing machine shall be properly scraped and pre-rinsed and shall be stacked in racks or trays so as to avoid overcrowding, and so as to permit the wash and rinse waters to reach all surfaces of each utensil."

"In machine washing, multi-use eating and drinking utensils shall be washed in water containing a suitable detergent at a temperature from 120 degrees F. to 140 degrees F. or other method approved by the Department of Health.

"The water in the wash tank shall be changed during operation as often as is necessary to keep it reasonably clean. An effective concentration of detergent in the wash water shall be maintained at all times."

"Bactericidal treatment shall consist of exposure of all surfaces of dishes and utensils being washed to a rinse of clean water, at a temperature of not less than 180 degrees F. or other method approved by the Department of Health."

"All dishwashing machines shall maintain a flow pressure not less than 15 or more than 25 pounds per square inch on the fresh water line at the machine and not less than 10 pounds per square inch at the rinse nozzles. A suitable gauge cock shall be provided immediately upstream from the final rinse spray to permit checking the flow of the final rinse water. An easily readable thermometer accurate to ± 2 degrees F. shall be provided on both the wash and rinse water lines of the dishwashing machine which will indicate the temperature of the water solution therein."

"Dishwashing machines shall be thoroughly cleaned at least once each day. The pumps and the wash and rinse sprays or jets shall be so designed that a forceful stream of water will reach all surfaces of the utensils when they are properly racked. These parts shall be thoroughly cleaned at least once each day. The pumps and the wash and rinse sprays or jets shall be so designed that a forceful stream of water will reach all surfaces of the utensils when they are properly racked. These parts shall be readily accessible for inspection and cleaning."

"After bactericidal treatment, utensils and containers shall be stored at a sufficient height above the floor in a clean, dry place, protected from flies, splash, dust, overhead leakage and condensation, and other contamination. Containers and utensils shall be inverted, covered, or otherwise protected from contamination until used for serving."

Drain racks, trays, and shelves shall be made of non-corrodible material and shall be kept clean.

In handling containers and utensils the surfaces thereof which come in contact with food or drink shall not be touched by the hands, except during the process of washing.

Tables for clean and dirty dishes and food shall be so arranged that the dirty dishes will be as far removed from the food and clean dishes as may be possible.

All single-service articles and utensils shall be purchased in sanitary cartons and stored therein in a clean, dry place until used, and after removal from the cartons, these articles shall be handled in such a manner as to prevent contamination.

Please note the following procedures must be followed for City of Chicago Approval:

- 1. All low energy models must have low-level sani alarms, both visual and audio.**
- 2. All models must have a City of Chicago approval data label affixed to the machine.**
- 3. Chlorine sanitizer must be a minimum of 100 PPM.**

5. Electrical Diagram

