

Owner's Manual

Keep with machine for reference

PKC24

INSTALLATION & OPERATION

REV.11.09



Perlick Corporation
8300 W Good Hope Rd
Milwaukee, WI 53223

800-558-5592

FAX 414-353-7069

perlick.com

TABLE OF CONTENTS

MODEL PKC24

1. RECEIVING	2
2. SPECIFICATIONS	3
3. INSTALLATION	4
3.1. ELECTRICAL	4
3.2. PLUMBING	4
4. OPERATION	5
4.1. FILLING OF THE WASH TANK	5
4.2. OPERATION INSTRUCTIONS	5
4.2.1. <i>Proper Chemical Dosage</i>	5
4.3. CLEANING INSTRUCTIONS	6
4.3.1. <i>Highly Recommended Daily Cleaning Instructions</i>	6
4.3.2. <i>Weekly Cleaning Instructions</i>	6
5. TROUBLESHOOTING	7
6. PARTS MANUAL	9
6.1. INITIAL PARTS KIT P/N 1100.47	9
6.2. EXPLODED VIEW DRAWINGS	10
6.2.1. <i>Main Assembly</i>	10
6.2.2. <i>Conveyor Wheel / Curtain</i>	11
6.2.3. <i>Conveyor Shut-Off Rod Assembly</i>	12
6.2.4. <i>Control Box Assembly</i>	13
6.2.5. <i>Soap Tank Assembly</i>	14
6.2.6. <i>Water Inlet Plumbing</i>	15
6.2.7. <i>Sanitizer Plumbing Component Hardware</i>	16
6.2.8. <i>Vacuum Breaker and Hardware</i>	17
6.2.9. <i>PKC24 Wash Pump Assembly</i>	18
6.2.10 <i>Conveyor Drive Assembly</i>	19
6.2.11 <i>PKC24 Waste Collector Assy.</i>	20
7. ELECTRICAL DIAGRAM	21

1. Receiving

1. Remove all packing material from the machine.
2. Remove all tape securing components within the machine. Check that both trays are positioned properly.
3. Check for the following component parts:
 - A. Check that the rinse screen is secure in the rinse drain.
 - B. Check the position of the PKC24 curtains.
 - C. Check that the conveyor is level and the drive gear is engaged in the conveyor's outer rim grooves.
 - D. Important: Check and remove overflow drain tube, which is secured to the front of the scrap tank, behind the access door. Place it in position in soap tank.
 - E. Check that the screen in the detergent tank is in position.
 - F. Check that the drain screen is in position.
4. Important: Read all instructions completely.



2. Specifications

WATER CONSUMPTION		
HOT WATER INITIAL FILL	3 GAL.	11.35 L.
HOT WATER PER HOUR (max)	12 GAL.	45.42 L.
COLD WATER PER HOUR	168 GAL.	636 L.
OPERATING CAPACITY		
(2-1/2") GLASSES PER HOUR	1000	-
WATER REQUIREMENTS		
COLD WATER INLET	1/2"	-
HOT WATER INLET	1/2"	-
DRAIN CONNECTION	1-1/2"	-
TEMPERATURES		
INLET COLD WATER	75 °F	24°C
INLET HOT WATER (recommended)	140°F	60°C
FRAME DIMENSIONS		
DEPTH	25-1/8"	63.8CM
WIDTH	25-1/4"	64CM
HEIGHT	39"- 40-1/2"	99 -102.8CM
MAX CLEARANCE FOR GLASSES	11-3/4"	29.9CM
ELECTRICAL	120 VAC 11 AMPS	
TANK HEATER (Not Booster Heater)	1.25KW	
WASH PUMP MOTOR	.1HP	
SHIPPING WEIGHT		
PKC24 (Approximate)	156#	71 kg

3. Installation

3.1. Electrical*

A 15 Amp, 120 Volt, 60 Hz dedicated circuit should be used to supply electrical power to the PKD24 machine (see specification sheet page 3). The power connection with the leads L-1, L-2 (N) and Ground must be such that there is sufficient length of flexible conduit to permit the machine to be moved for cleaning.

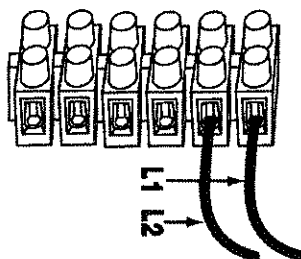

Note: For cord-connected machines provide a grounding receptacle.

3.2. Plumbing*

Making Cold Water Connection

1. Connect a cold 1/2" water line to the cold water solenoid valve and inspect for leaks. Water flow pressure should be between 20-100 PSI.
2. Cold-water usage is approximately 2.8 U.S. gpm.
3. Machine is equipped with a mixing valve located between hot and cold solenoid valves (See section 6.2.6. Water Inlet Plumbing item 5). Open until temperature reaches 75°F for areas with very cold rinse water to heat the rinse water, which will prevent glasses from cracking.

Caution: Open mixing valve just enough to raise cold-water temperature to 75°F only, otherwise cold water supply will be affected. Do not leave mixing valve p/n 41014.49 all the way open.

Making Hot Water Connection

1. Connect a hot 1/2" water line to the hot water solenoid valve. The temperature must be minimum 140°F/60°C with flow pressure between 20-100 PSI.
2. Hot water usage is approximately 12 U.S. gph.

Making Drain Connection

1. Connect a 1-1/2" PVC drain line to the bottom of the scrap tank. (note: machine is gravity drain)

***Electrical and plumbing connections must be made by a qualified person who will comply with all available Federal, State, and Local Health, Electrical, Plumbing and Safety codes.**

4. Operation

4.1. *Filling of the Wash Tank*

- With overflow drain tube in place in the detergent tank proceed to following.
- Turn power on-off/flush switch to the "ON" position. The water solenoid will activate and fill soap tank until the proper level is reached, also activating heating element.
- Set the thermostat for minimum 140°F/60°C. The wash tank temperature is regulated by heater and thermostat.

4.2. *Operation Instructions*

- Open the door; place on-off/flush switch to the "ON" position. The wash tank will begin its automatic fill cycle.
- Verify product containers have chemicals.
- Detergent is fed from the supply container into the detergent tank in controlled amounts by the detergent pump. Use detergent at strength recommended by your chemical supplier.
- Place glasses on the conveyor wheel. Push conveyor rocker switch located on front right side of machine. The conveyor wheel will stop and start with conveyor shut-off rod.

4.2.1. **Proper Chemical Dosage**

The amount of chemical delivered, whether it is detergent, sanitizer or rinse aid, is controlled using the set screw located on the circuit board attached to the control box.

- For detergent, contact your chemical supplier for proper type and detergent concentration.
Note: Detergent pump only operates when hot water tank is filling or when prime switches are activated.
- Circuit board basic settings are: arrow facing 9:00 for sani and rinse, 12:00 for detergent.

Adjustments To Detergent Pump:

- When replacement container is installed, push the prime switch in and hold until the detergent feed line is full.
- Securely place overflow drain tube into soap tank and switch power on-off/flush switch to the "ON" position. The detergent dispenser will automatically dispense soap as the soap tank fills with water.
- The quantity of product can be regulated at the circuit board using the set screw.

Adjustments To Sanitizer Pump:

- Follow same procedures as detergent for priming chemical.
- Push conveyor rocker switch located on the front of the machine. Place sanitizer test strip under the final rinse and read for proper level.
- The quantity of product can be controlled at the sani circuit board set screw.

Note: Use chlorine test papers to verify and monitor the 50ppm chlorine level

Adjustments To Rinse Agent Pump:

- Follow same procedures as detergent for priming chemical.
- Cycle glasses through machine and verify rinse agent is feeding properly. Increase rinse aid as necessary by turning up or down circuit set screw.
- Basic circuit board setting is 9:00.

Note: To meet standards set by NSF, chlorine at 50ppm must be used in the final rinse.

4.3. Cleaning Instructions

4.3.1. Highly Recommended Daily Cleaning Instructions

Remove optional PKC24 drain tray & waste collector from the front of your glasswasher and clean thoroughly.

Turn power switch off behind front service door.

Remove all trays, screens and curtains. Wash, rinse them thoroughly and allow to dry.

Move shut-off rod to side and remove conveyor hub and wheel from machine.

Remove and clean wash and rinse arms. Wash tube brush and jet reamer supplied for cleaning of arms.

CAUTION: Do not twist spray arms, pull straight out or they will break

Install wash and rinse arms (Wash and rinse arms are different. The receiver arm sockets are molded differently to prevent placing arms in wrong location).

Use reverse procedures for placing conveyor wheel and hub back into position.

Note: conveyor motor can be pulled to the side as your placing wheel into position. Open front access door and pull conveyor motor toward you as seat the conveyor wheel into position.

Place conveyor hub in center of conveyor, align shut-off rod to normal position. Install left and right trays, making sure shut-off rod is positioned between guide brackets. Install curtains into their holders.

Upper and lower wash tank screens should be removed and cleaned thoroughly.

Pull the drain tube from the soap tank and clean the tank.

Insert overflow drain tube and wash tank screens back to appropriate placement.

Reattach optional PKC24 waste collection assembly.

Check product levels and close front service door.

4.3.2. Weekly Cleaning Instructions

Remove upper and lower wash and rinse arms from their spray bases, remove end plugs, and clean spray tubes with Cleaning Drill p/n 00899.01, Cleaning Brush p/n 00899.02 provided.



Maintenance

5. Troubleshooting

PROBLEM	LIKELY CAUSE	SOLUTION
The soap tank water temperature low	Thermostat malfunction	Replace
	Thermostat set too low	Turn thermostat up
	Bad heater	Replace
	Float switch malfunction	Remove and replace
	Water supplied to machine low	Must provide 140°F
Low or no pressure in rinse spray arms	Rinse spray arms dirty	Clean spray arms with cleaning drill and brush provided
	Shut-off valve on supply line may be closed	Open valve
	Spray arm pressure low	Minimum 20-100PSI flow pressure required
No rinse arm water	Rinse solenoid valve non-operational	Check coil Check and install rebuild kit Replace if necessary
	Solenoid valve strainer or restrictor disc plugged	Remove screen and clean- replace or clean flow restrictor
Product containers filling with water	Plugged rinse arms	Clean
	Worn flow restrictor in solenoid valve	Replace
No chemical being dispensed	Empty product in containers	Refill containers
	Chemical lines plugged	Flush lines with hot water and condition of chemical
	Strainer on pick-up tube plugged	Clean with hot water
	Circuit board setting too low	Increase by turning clockwise while machine is running/filling
	No power to pump	Check LED signal, all electrical connections
	Pump motor or circuit board defective	Replace pump motor or circuit board
Soap tank continues to fill with water with power off	Leaking solenoid valve diaphragm.	Inspect and clean seat Replace diaphragm kit Install new valve

Maintenance

PROBLEM	LIKELY CAUSE	SOLUTION
Moisture, condensation, wet areas behind service door	Pump seal leaking	Replace
	Detergent tank drain screen plugged	Clean
	Primary drain plugged	Clean
	Rinse water drain line backing up	Clear obstruction, clean machine
	Return screen in soap detergent tank plugged	Clean
	Covers on detergent tank are not installed properly causing condensation	Position all top covers to completely cover top of tank
Wheel not turning	Power off at circuit breaker	Reset circuit breaker
	Drive motor defective	Replace
	Micro switch on switch support bracket faulty or not making contact	Replace or make adjustment to switch
	Conveyor not engaged with drive gear	Position properly.
Low or no pressure coming from wash arms	No or low water in soap tank	Check water supply Check tank stand pipe position Check that fill switch is in On-Fill position and that tank fills with water Check float switch operation Check hot fill solenoid is operational
	Obstruction in wash arm	Clear obstruction
	Wash Pump not running	Check power supply Check pump capacitor Replace pump
	Pump running but no pressure to wash arms.	Inspect the impeller Replace if needed
Water spraying out conveyor entrance	Spray arms not locked in place	Spray arms must be pushed firmly on to hub connection on spray base
	Spray arms plugged	Clear and clean with cleaning drill, scraper, and brush
	Splash curtain not in position	Install or adjust
	Machine in operation without any glasses on conveyor	Operate machine with a full load of glasses



6. Parts Manual

6.1. Initial Parts Kit p/n 1100.47

P/N	DESCRIPTION	Qty
*00120.00	Thermometer (Bi Metal)	1
00201.49	Wash Pump	1
00308.47	Spray Arm End Plug	3
00421.47	Conveyor Rocker Switch	1
00472.47	GL-C Conveyor Shut Off Switch	1
*00631.00	Ice Cube Relay 120V, 12A	1
00631.49	Ice Cube Relay 120V, 20A	1
00715.47	3/8" Check Valve	1
00810.49	GL-C Drive Motor 120V	1
00811.47	Drive Motor Spring	1
00815.00	GL-C Peri Pump Complete	1
00820.00	GL-C Peri Pump Circuit Board	1
00821.00	GL-C Transformer	1
00839.00	Squeeze Tube w/conn.	3
00899.01	Cleaning Drill	1
00899.02	Cleaning Brush	1
03470.47	Power on-off/ Flush Switch	1
*03475.00	Primer Switch - Push Button	1
*03623.00	1/2 Vac Breaker Repair Kit Watts	1
15417.30	1250 Watt Heater	1
*13417.89	Heater Thermostat (EGO)	1
13418.49	GL-C Auto-Fill Timer	1
*13605.00	Pressure Gauge	1
13703.47	GL-C Curtain – Full Size	1
13703.57	GL-C Curtain – Half Size	1
41015.49	Solenoid Valve 3/8" 120V	1

NOTE: Important! Perlick recommends that the initial parts kit be purchased immediately and kept on hand as a back up supply of critical parts in the event your machine should require emergency service.

All the parts included in this kit are unique to the PKC24 glasswasher (except those with *).

Parts Manual

6.2. Exploded View Drawings

6.2.1. Main Assembly

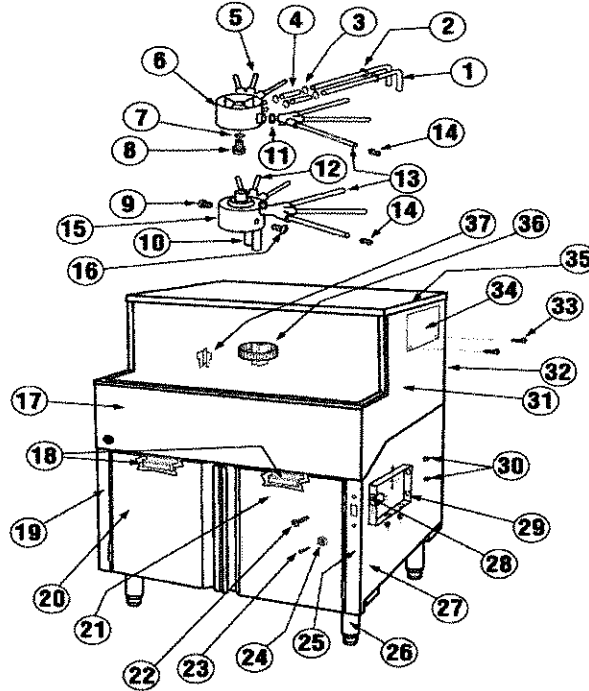

ITEM NO.	NO. REQ'D	P/N	DESCRIPTION
1	2	05004.00	Upper Spray Base Inlet Tube
2	2	14754.10	Grommet
3	4	03101.47	Clamp #6
4	1	03106.47	Braided Hose 3/8"
5	2	14755.00	Wash Arm
6	1	14752.00	Upper Spray Base
7	1	00924.00	Washer, 1/4"
8	1	00910.00	Bolt, 1/4-20 x 1 1/2"
9	4	00940.60	Screw, 10-32 x 3/8"
10	1	14756.00	Lower Spray Base Inlet Tube
11	4	14752.10	Spray Base "O" Ring
12	2	14755.00	Wash Arm
13	2	14754.00	Rinse Arm
14	6	00308.47	Spray Arm End Plug
15	1	14753.00	Lower Spray Base
16	2	00940.50	Screw, 10-32 x 3/8"
17	1	16302.50	PKC24 Face Trim
18	2	00812.47	Magnetic Door Catch
19	1	16302.65	PKC24 Front Pillar (Left Hand)
20	1	16306.00	PKC24 Left Door

*Not shown.

ITEM NO.	NO. REQ'D	P/N	DESCRIPTION
21	1	16306.50	PKC24 Right Door
22	2	00940.50	Screw, 10-32 x 3/8"
23	1	00941.00	10-32 X 5/8 Panhead Screw
24	1	00421.45	GL-C Switch Bumper
25	1	16402.60	Front Pillar (Right Hand) 2" taller
26	4	01146.00	Leg 6-1/2"- Thread
27	1	16331.00	PKC24 Base
28	1	00421.47	Conveyor Rocker Switch
29	1	16514.50	Conveyor Switch Box
30	4	00438.00	Snap Bushing Universal 875-11
31	1	16302.00	PKC24 Side Panel Wrap
32	1	16330.00	PKC24 Wash Tank
33	4	00940.60	Screw, 10-32 x 3/8"
34	1	16510.50	Vacuum Breaker Access Cover
35	1	16513.00	Top Panel
36	1	16571.20	Deflector Screen (Rinse)
37	1	16571.00	Drain Deflector (Wash)
38	1	16530.50	Tank Support Bracket *
39	1	00860.01	GL-C Moisture Pad 10 x 23 *
40	1	00860.02	GL-C Moisture Pad 3 x 23 *
41	1	00860.03	GL-C Moisture Pad 10 x 12 *

Parts Manual

6.2.2. Conveyor Wheel / Curtain

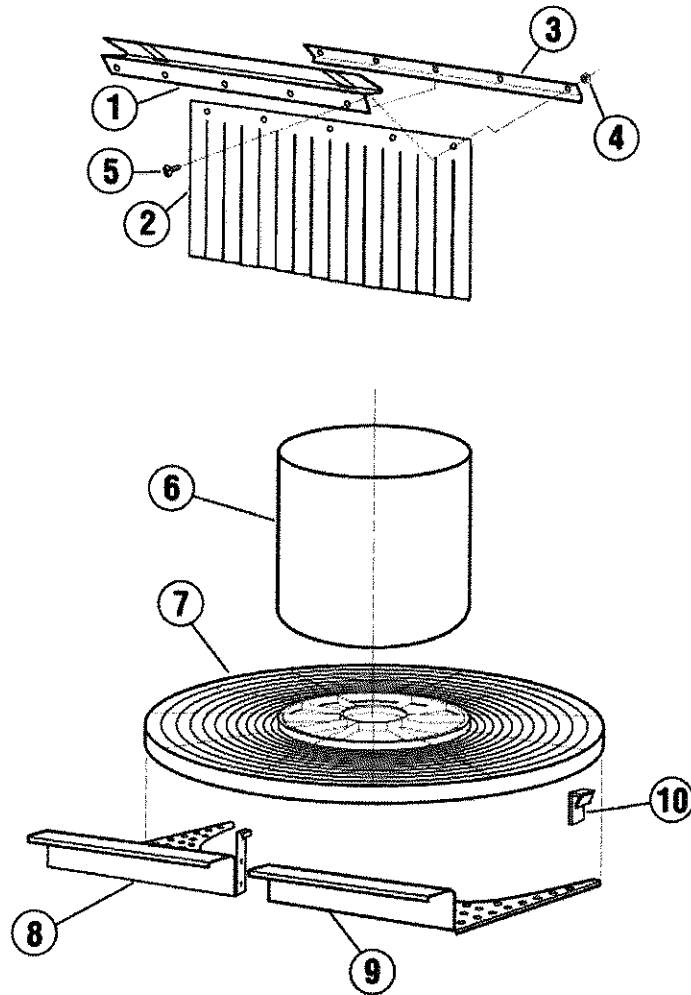

ITEM NO.	NO. REQ'D	P/N	DESCRIPTION
1	1	16505.00	Curtain Support
2	1	13703.47	GL-C Curtain
3	1	16505.10	Curtain Clamp
4	8	00927.00	Nut, 8-32
5	8	00911.50	Screw, 8-32 x 3/8"

ITEM NO.	NO. REQ'D	P/N	DESCRIPTION
6	1	16451.00	Conveyor Hub 2" taller
7	1	14750.00	Conveyor Turntable
8	1	16350.50	PKC24 Tray- Left
9	1	16350.00	PKC24 Tray- Right
10	4	14750.10	Turntable Glide Block

6.2.3. Conveyor Shut-Off Rod Assembly

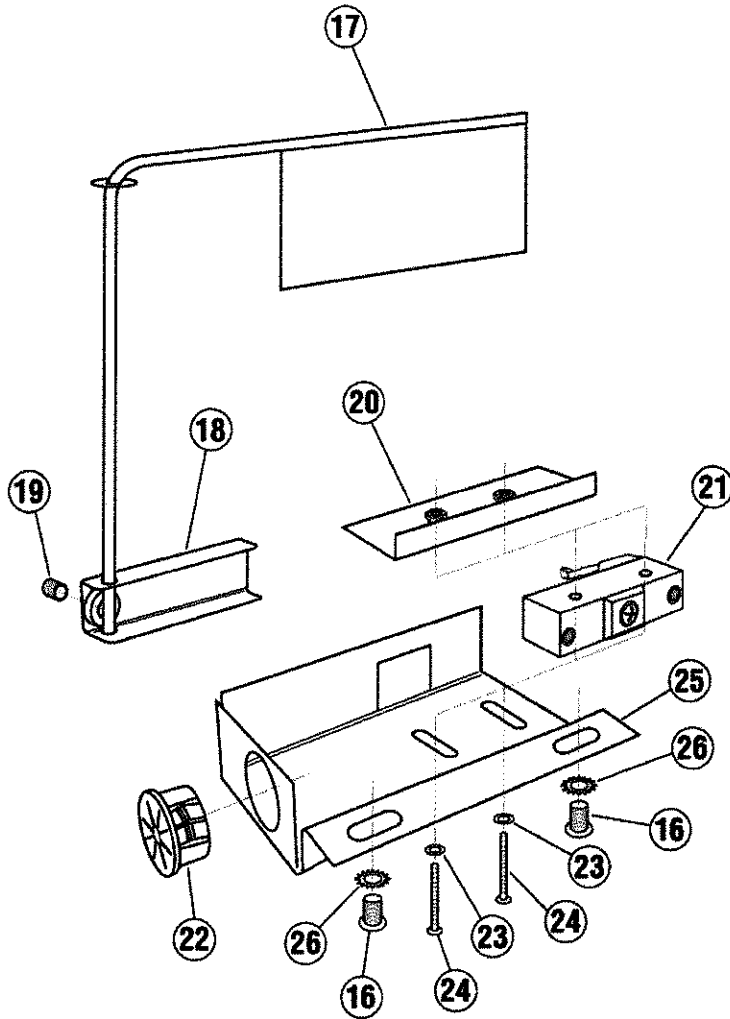

16	2	00940.50	Truss Head Screw 10-32 x 3/8"
17	1	16320.00	PKC24 Shut-off Rod
18	1	16521.00	Activator
19	1	00935.00	Socket Set Screw, 1/4-20 x 1/4"
20	1	16514.30	Nut Plate
21	1	00472.47	Conveyor Shut Off Switch
22	1	00438.00	Snap Bushing Universal 875-11
23	2	04806.00	#10 Brass Washer
24	2	01001.00	Pan Head Screw 6-32 x 1"
25	1	16514.00	Conveyor Shut Off Switch Brack.
26	2	03814.10	10-32 Lock Star Washer

Parts Manual

6.2.4. Control Box Assembly

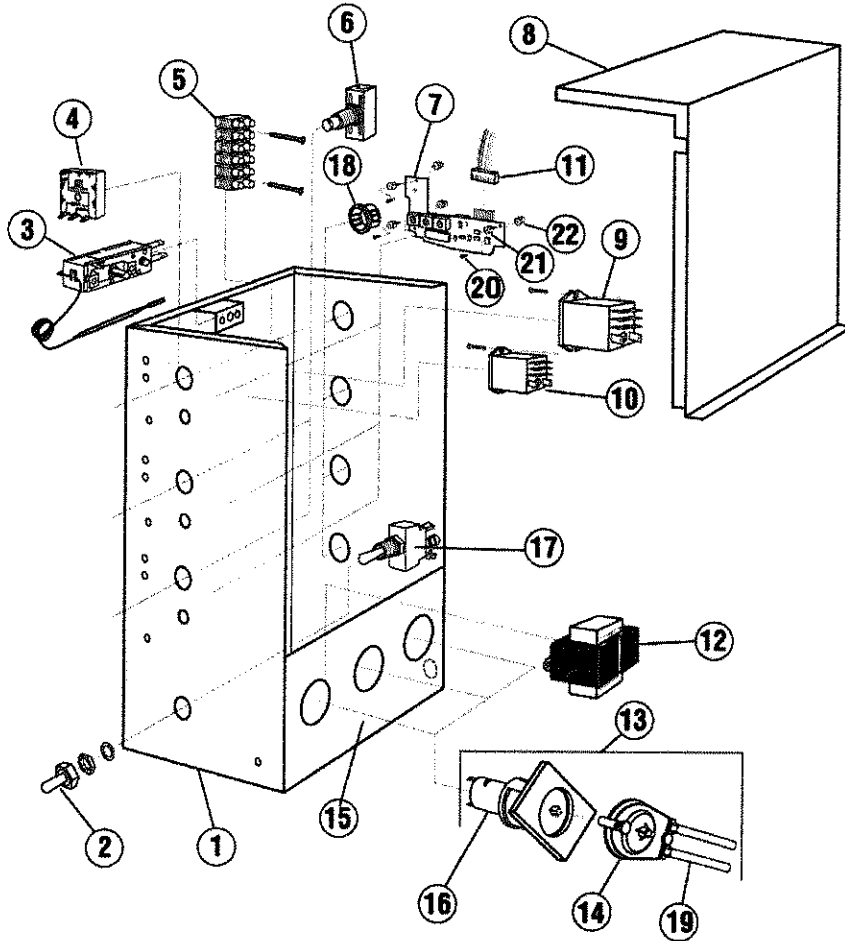

ITEM NO.	NO. REQ'D	P/N	DESCRIPTION
1	1	18611.47	GL-C Control Box
2	1	00470.10	Toggle Switch Rubber Boot
3	3	13417.89	Heater Thermostat (EGO)
4	1	13418.49	Auto-Fill Timer
5	1	00454.06	Power Block 6 Position
6	3	03475.00	Primer Switch - Push Button
7	3	00820.00	GL-C Peri Pump Circuit Board
8	1	16504.00	GL-C Control Box Lid
9	1	00631.49	Ice Cube Relay 120V, 20A
10	2	00631.00	Ice Cube Relay 120V, 12A
11	3	00821.21	Circuit Board Connector
12	1	00821.00	GL-C Transformer
13	1	00815.00	GL-C Peri Pump Complete

ITEM NO.	NO. REQ'D	P/N	DESCRIPTION
14	1	00818.00	GL-C Peri Pump Cover
15	1	16515.00	GL-C Peri Pump Panel
16	1	00816.00	GL-C Peri Pump Gear Motor
17	1	03470.47	Power on-off/ Flush Switch
18	4	00438.00	Snap Bushing Universal 875-11
19	3	00839.00	GLC Squeeze Tube w/ conn.
20	3	03826.47	4-40x3/16 Pan Head Screw
21	3	00820.06	Circuit Board Stand off
22	3	00820.07	Circuit Board Stand off Cap
23	9	00820.10	Circuit Board Spacer Large *
24	3	00820.20	Circuit Board Connector *
25	9	00821.11	Circuit Board Spacer Small *

*Not shown

Parts Manual

6.2.5. Soap Tank Assembly

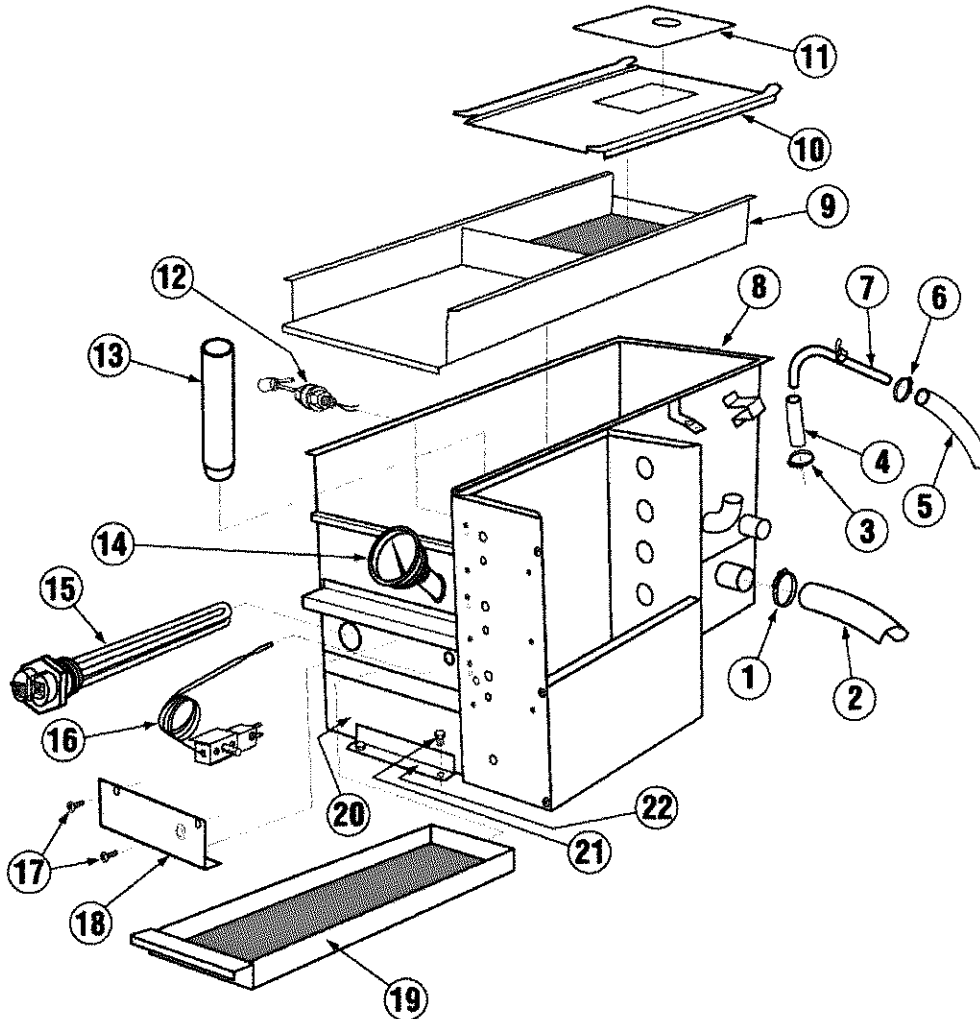

ITEM NO.	NO. REQ'D	P/N	DESCRIPTION
1	1	03101.49	Hose Clamp #24
2	1	03106.40	Ribbed Drain Hose 1 1/2" ID
3	1	03101.00	Hose Clamp # 16 1"
4	1	03108.60	Transfer Hose 1" Reinforced
5	1	03106.45	Braided Hose 1/2"
6	1	03101.47	Hose Clamp #6
7	1	05012.00	1/2 Cu Ref Tubing (Per Foot)
8	1	16541.00	Detergent tank
9	1	16544.00	Detergent Tank Screen
10	1	16543.00	Detergent Tank Rear Cover
11	1	16542.00	Detergent Tank Lid

ITEM NO.	NO. REQ'D	P/N	DESCRIPTION
12	1	13463.00	Liquid Level Switch
13	1	16545.50	Overflow Drain Tube
14	1	00120.00	Thermometer Bi Metal
15	1	15417.30	1250 W, 120V Heater
16	1	13417.89	Heater Thermostat (EGO)
17	2	00940.50	10-32 X 3/8" Truss Head Screw
18	1	16522.00	Heater Cover
19	1	16579.20	Drain Screen
20	1	16579.00	Drain Pan
21	2	00906.00	1/4-20 X 1/2" Hexhead Bolt
22	1	16530.50	Tank Support
23	1	40116.00	1/4 Comp X 1/4 MIP Ftg (not shown)

Parts Manual

6.2.6. Water Inlet Plumbing

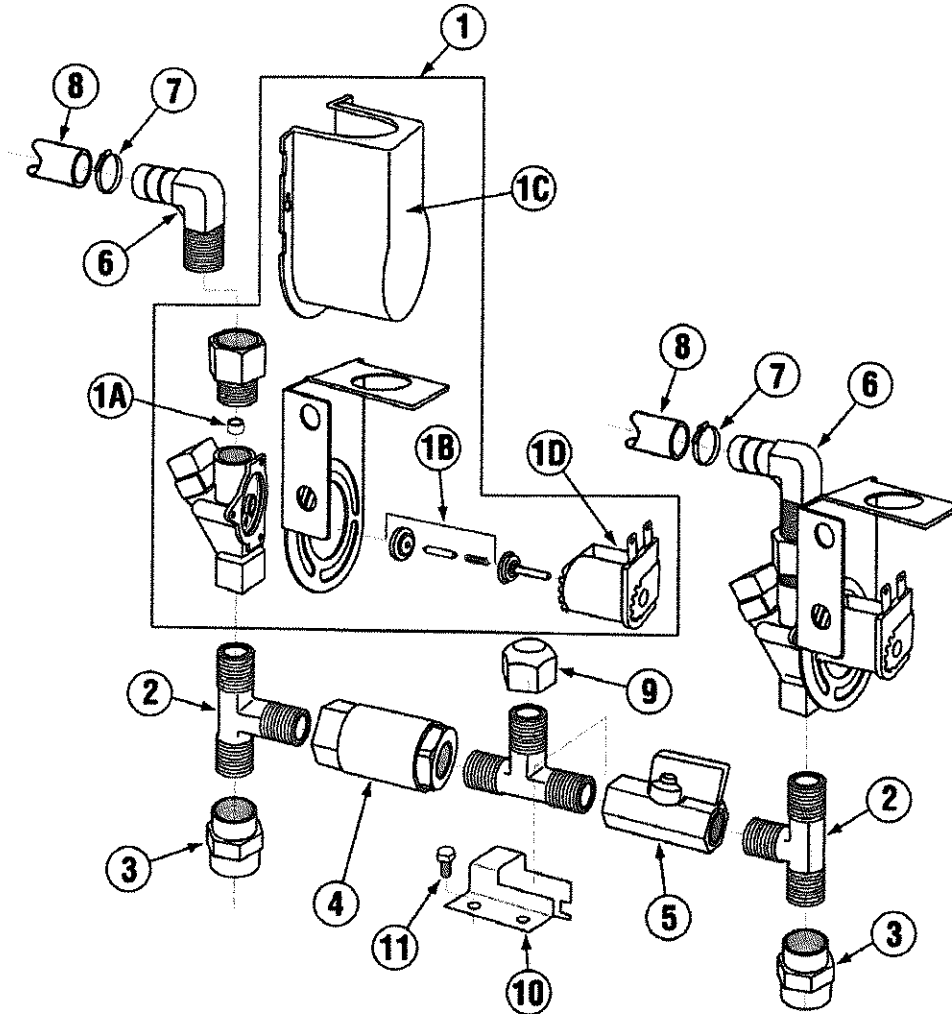

ITEM NO.	NO. REQ'D	P/N	DESCRIPTION
1	2	41015.49	Solenoid Valve 3/8" 115V
1A	2	41015.77	Flow Washer
1B	2	N/A	3/8" Solenoid Valve Repair Kit
1C	2	N/A	3/8" Solenoid Valve Cover
1D	2	41015.60	3/8" Solenoid Valve Coil
2	3	40010.00	GL-C 3/8" MPT Tee
3	2	40017.00	GL-C 1/2 x 3/8" FPT Reducer
4	1	00715.47	GL-C 3/8" Check Valve

ITEM NO.	NO. REQ'D	P/N	DESCRIPTION
5	1	41014.49	GL-C 3/8" Ball Valve
6	2	40012.10	GL-C 1/2 Barb x 3/8" MIP Elbow
7	2	03101.47	Hose Clamp #6
8	1	03106.45	Braided Hose 1/2"
9	1	40016.00	Brass Cap
10	1	16525.00	Plumbing Strap
11	2	00914.10	1/4-20 x 5/8" Hexhead Bolt

Parts Manual

6.2.7. Sanitizer Plumbing Component Hardware

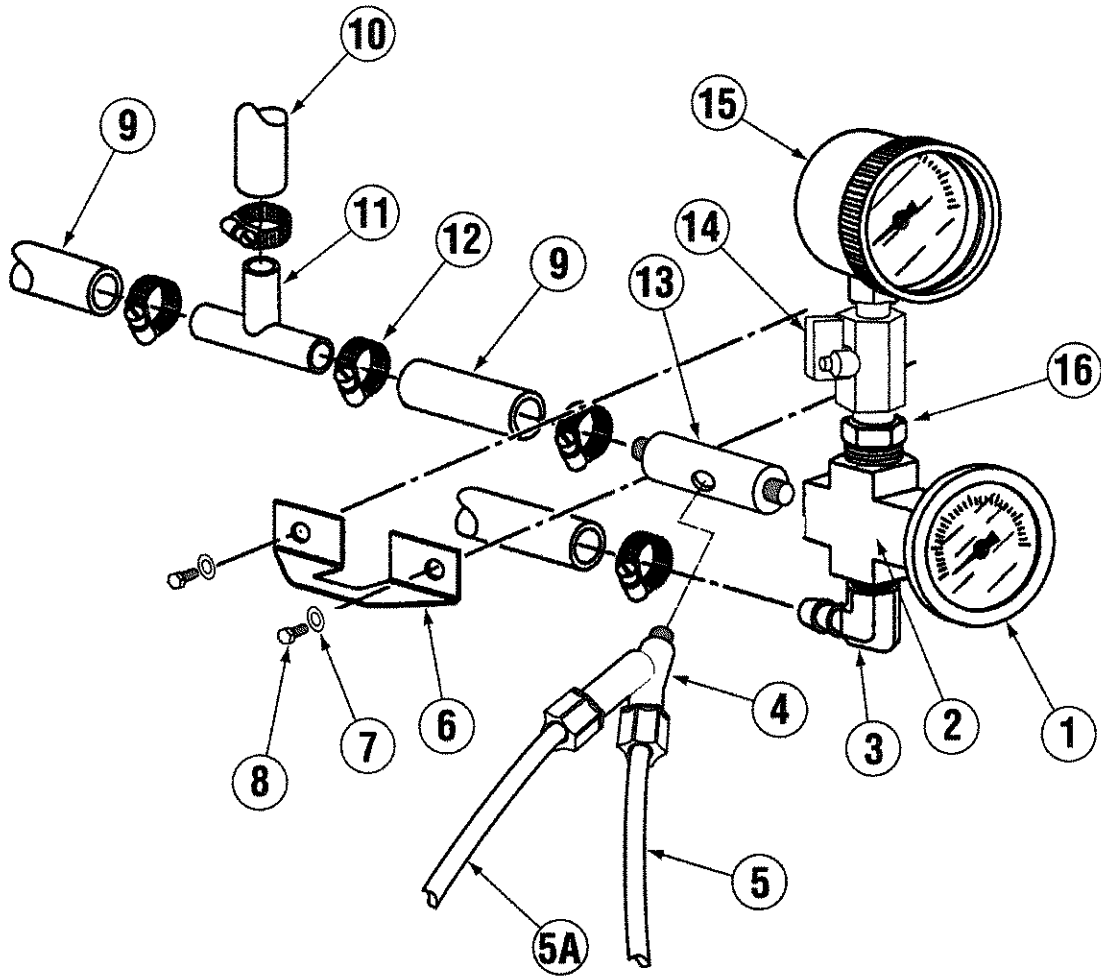

ITEM NO.	NO. REQ'D	P/N	DESCRIPTION
1	1	00120.00	Thermometer
2	2	40011.00	3/8" FPT Cross Connector
3	1	40012.00	3/8" MPT x 1/2" 90° Hose Barb
4	1	00826.00	Dual Inlet Chemical Injector
5	1	00425.51	Chemical Tubing Blue
5A	1	00425.54	Chemical Tubing White
6	1	16526.00	Gauge Bracket
7	2	00924.00	Lock Washer, 1/4
8	2	00912.00	Nut, 1/4-20

ITEM NO.	NO. REQ'D	P/N	DESCRIPTION
9	1	03106.45	1/2" I.D. Braided Hose
10	1	03106.47	3/8" I.D. Braided Hose
11	1	00434.49	1/2 x 1/2 x 3/8" Tee
12	5	03101.47	7/16" Gear Clamp
13	1	13699.47	Mixing Chamber
14	1	41014.47	1/4"MxF Mini Ball Valve
15	1	13605.00	0-30 PSI Pressure Gauge
16	1	40015.00	3/8 x 1/4" Reducer Bushing

Parts Manual

6.2.8. Vacuum Breaker and Hardware

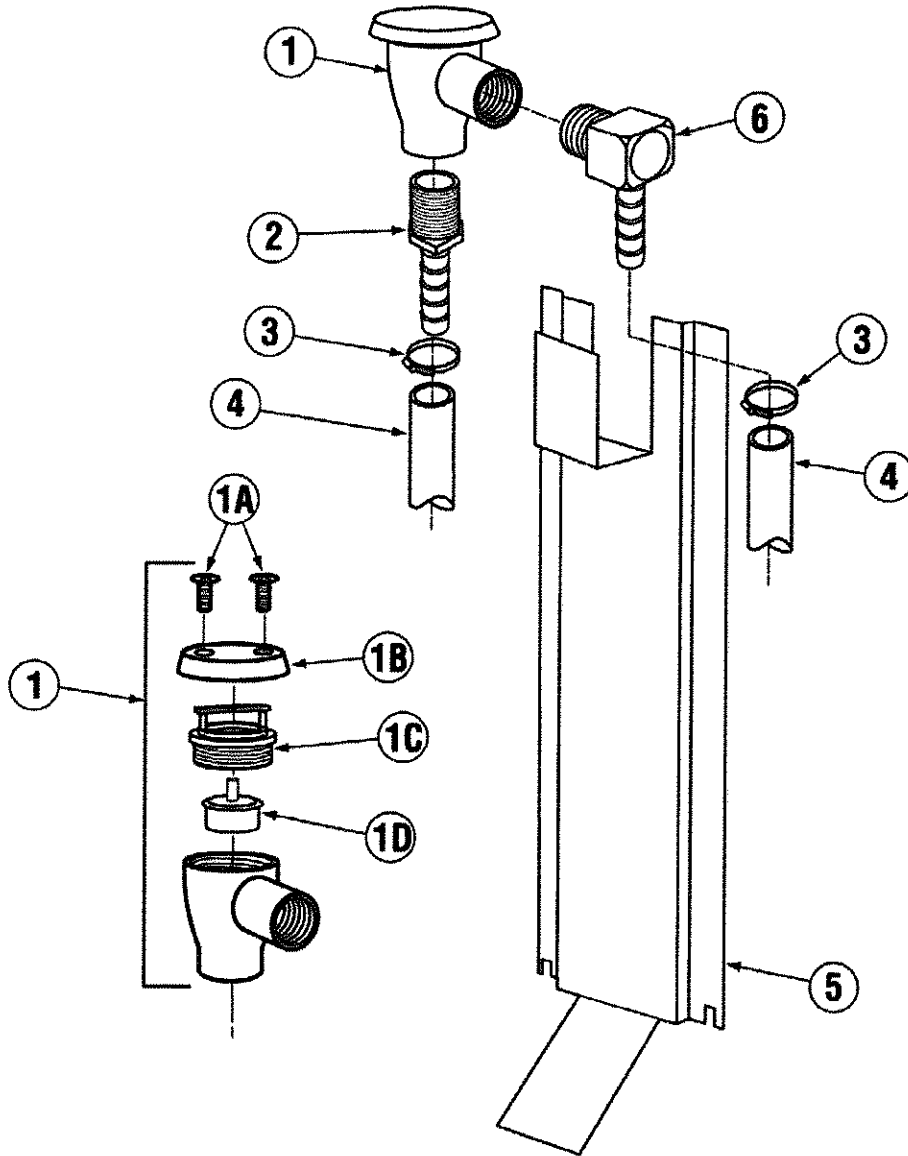

ITEM NO.	NO. REQ'D	P/N	DESCRIPTION
1	1	03624.00	1/2" Vacuum Breaker
1A	2	00421.51	6-32 x 1/4" SS Panhead Screw
1B	1	00739.50	Vacuum Breaker Cap
1C	1	03624.25	1/2" Vacuum Breaker Bonnet
1D	1	03623.00	1/2" Vacuum Breaker Repair Kit

ITEM NO.	NO. REQ'D	P/N	DESCRIPTION
2	1	40014.00	1/2" MPT x 1/2" Hose Barb
3	2	03101.47	7/16" Clamp
4	1	03106.45	1/2" I.D. Braided Hose
5	1	16410.00	Vacuum Breaker Support 2" taller
6	1	40013.00	GL-C 1/2 Barb x 1/2 MPT 90deg

Parts Manual

6.2.9. PKC24 Wash Pump Assembly

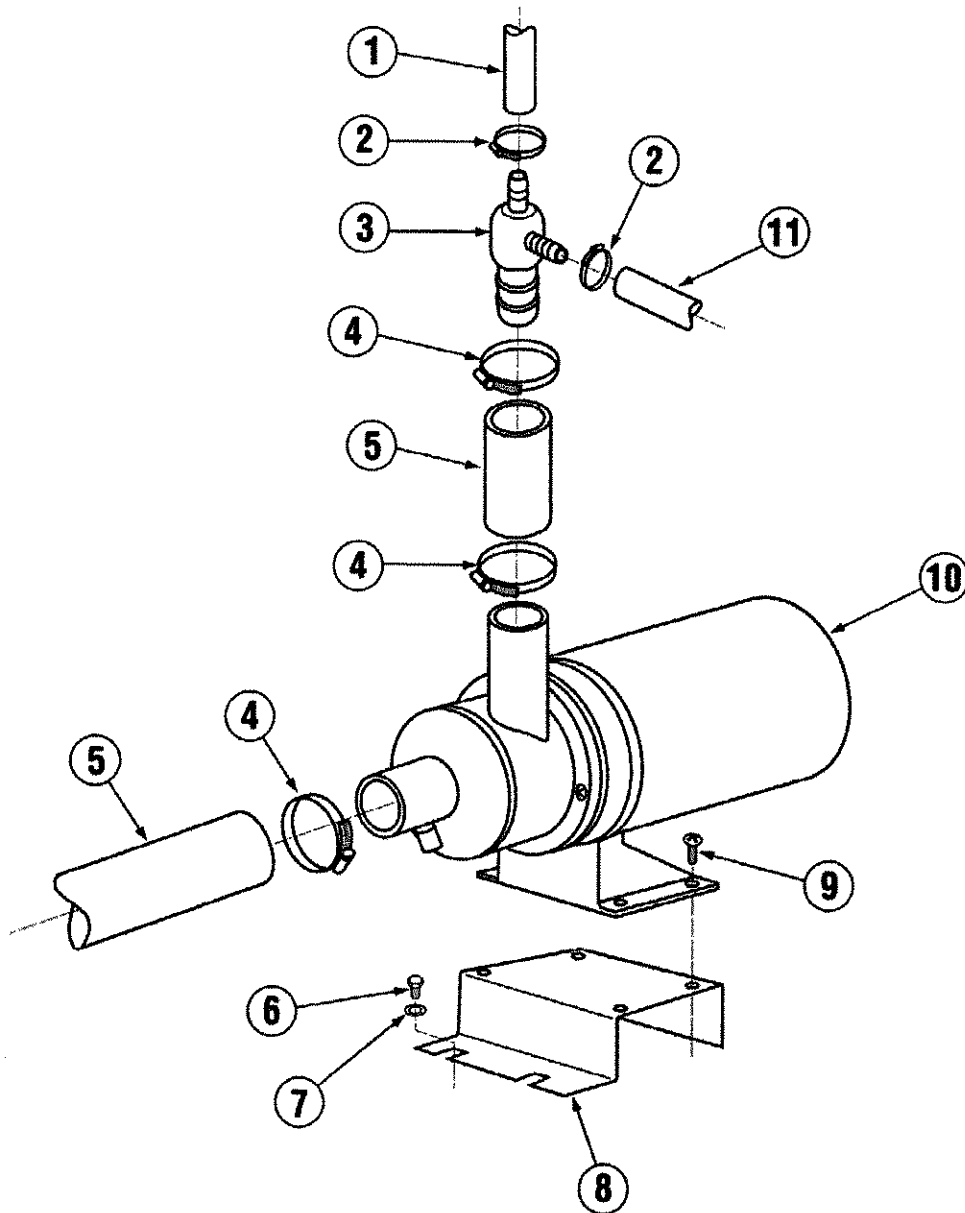

ITEM NO.	NO. REQ'D	P/N	DESCRIPTION
1	1	03106.45	1/2" Braided Hose
2	2	03101.47	Hose Clamp #6
3	1	00434.47	Pump Hose Adapter
4	1	03101.00	Hose Clamp #16
5	1	03108.60	Transfer Hose 1" Reinforced
6	2	00914.10	1/4-20 X 5/8 Hexhead Bolt
7	1	00924.50	1/4" SS Washer x 3/4" OD

ITEM NO.	NO. REQ'D	P/N	DESCRIPTION
8	1	16370.75	PKC24 Wash Motor Base
9	4	00911.50	8-32 X 3/8 Pan Head Screw
10	1	00201.49	Wash Pump Motor-GRI 115V
		00201.45	Wash Pump Motor-Laing 115V
		00201.46	Wash Pump Motor-FIR115V
11	1	03106.47	3/8" Braided Hose

Parts Manual

6.2.10 Conveyor Drive Assembly

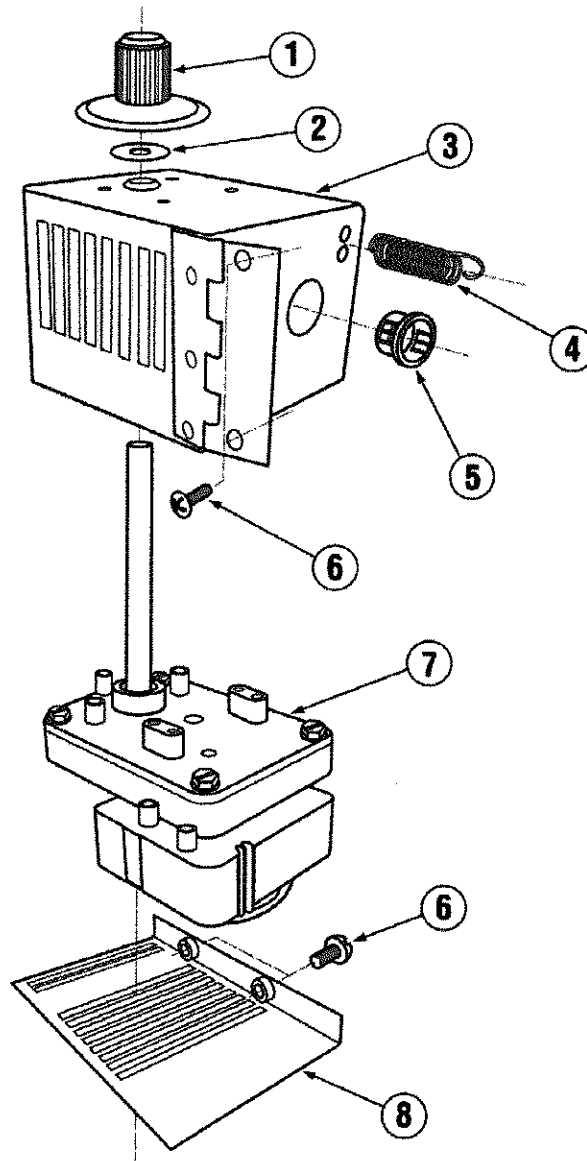

ITEM NO.	NO. REQ'D	P/N	DESCRIPTION
1	1	14751.00	Drive Gear
2	1	00104.83	VA Drain Motor Shaft Gasket
3	1	16570.50	Drive Motor Housing
4	1	00811.47	Extension Spring

ITEM NO.	NO. REQ'D	P/N	DESCRIPTION
5	1	00438.00	Snap Bushing Universal 875-11
6	4	00940.50	Screw, 10-32 x 3/8"
7	1	00810.49	Drive Motor
8	1	16570.60	Drive Motor Housing Cover

Parts Manual

6.2.11 PKC24 Waste Collector Assy.

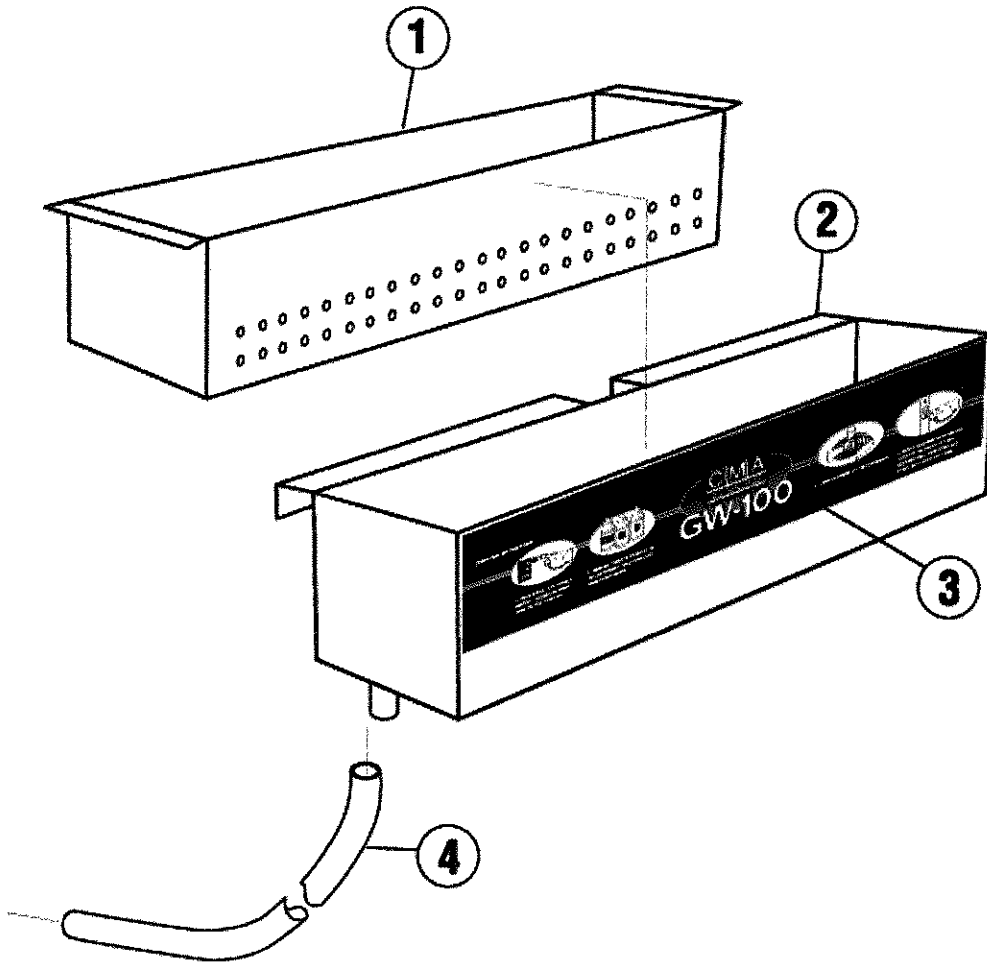

ITEM NO.	NO. REQ'D	P/N	DESCRIPTION
1	1	16562.00	GL-C Waste Collector Screen
2	1	16560.00	GL-C Waste Collector Tray
3	1	06231.56	PKC24 Label
4	1	03106.51	Clear Vinyl Tubing 1/2" ID x 3/4"OD
5	1	00899.01	Cleaning Drill not shown
6	1	00899.02	Cleaning Brush not shown

7. Electrical Diagram

