



Installation & Operation Manual

Commercial Glasswasher
Model PKHT24



Model PKHT24 Shown





TABLE OF CONTENTS

Introduction..... 3

Specifications 4

 PKHT24 Operational Cycle 5

Getting Started..... 6

 Receiving and Installation..... 6

 Electrical..... 6

 Plumbing..... 6

 BETA Detergent and Rinse Dispenser 7

 Safety-Temp Feature 8

 Booster Heater Setup 9

 Installer Checklist 9

Operation..... 10

 Dema Flow Disc 10

 Rinse and Wash Temperatures 10

 Startup Procedures..... 10

 Operating and Cleaning Instructions 11

 Preventative Maintenance Chart 12

 Quick Service Guide..... 13

 Troubleshooting 14

Parts Kits..... 16

 Customer Notice..... 17

Electrical Diagrams 18

The PKHT24 is a hot water sanitizing, single rack, undercounter glasswasher. It is a stand-alone machine featuring a self-contained booster heater. The only external connections necessary are power supply, water supply, drainpipe, and optional chemical dispensers. The machine uses re-circulated wash water and fresh water final-rinse.

Operation of the PKHT24 is extremely user friendly. To initially fill the machine each day, push the switch marked "FILL". The machine is full when water begins to flow into the scrap tray. The booster tank heater will maintain the wash water temperature at 155°F. The booster heater will produce a minimum of 180°F final rinse water each cycle.

The supply water to the PKHT24 must be a minimum of 140°F at 24 psi (Pounds per Square Inch) with a 6 gpm (Gallons Per Minute) flow rate and 60 gph (Gallons Per Hour) recovery rate. The pipe supplying the water must be a minimum of a 1/2". The plumbing connection is located at the back of the machine. (See specification sheet). The drain is a 1" barbed fitting on the back of the machine for easy attachment of your drain hose.

This manual provides a complete reference guide to the PKHT24. The first section explains how the machine is packaged and what to look for when receiving the machine. This manual explains how to install and set up the machine for use. Requirements are given for plumbing, wiring, and space considerations. These are always taken into consideration by our well-trained sales representatives prior to the order being placed. In the manual, guidance is also given for installation to ensure that the machine will be able to run at optimum conditions.

The machine's functions are mostly automatic and take little training to put into full operation. The Operation section of the manual may be used for instruction and procedures when required. We make this portion of the manual easy to understand so that all levels of operators are able to understand the machine's operation. The Operation section also includes diagnostic considerations for the machine when problems occur.

We are committed to providing the best products and customer service, and we welcome your feedback.

SPECIFICATIONS

	METRIC EQUIVALENT	
WATER CONSUMPTION		
PER RACK	.75 GAL.	(2.83 L)
PER HOUR	17.9 GAL.	(67.6 L)
OPERATING CYCLE		
WASH TIME-SEC	94	94
RINSE TIME-SEC	16	16
DWELL TIME-SEC	10	10
TOTAL CYCLE	2 MIN.	2 MIN.
OPERATING CAPACITY		
RACKS PER HOUR	30	30
WASH TANK CAPACITY	2.5 GAL.	(9.46 L)
PUMP CAPACITY	38 GPM	(144 LPM)
WATER REQUIREMENTS		
REQUIRED MINIMUM TEMP. *	110°F	(43°C)
RECOMMENDED TEMP. **	140°F	(60°C)
WATER INLET	½"	1.27cm
DRAIN CONNECTION	1"	2.54cm
RINSE PRESSURE SET	20 PSI±5 PSI	1.41 kg/cm ²
CYCLE TEMPERATURES		
WASH-°F	150°F -160°F	(65.5°C/71°C)
RINSE -°F	180°F -195°F	(82°C/90°C)
FRAME DIMENSIONS		
DEPTH	25"	(63.5 cm)
WIDTH	24"	(60.96 cm)
HEIGHT	33 ¼"	(84.45 cm)
MAX CLEARANCE FOR GLASSWARE	11-1/4"	(28.6 cm)
ELECTRICAL RATING*	208 VOLTS 1 PH—60 Hz	230 VOLTS 1 PH—60 Hz
	33 AMPS	35 AMPS
BOOSTER HEATER	5.3 kW	6.5 kW
WASH PUMP MOTOR	¾ HP	¾ HP

THIS SYSTEM REQUIRES THREE POWER WIRES, WHICH INCLUDES A CURRENT CARRYING NEUTRAL. AN ADDITIONAL FOURTH WIRE MUST BE PROVIDED FOR MACHINE GROUND.

SHIPPING WEIGHT	234#	(106 kg)
------------------------	------	----------

* For machines having "SAFETY TEMP" feature. ** For faster heat recovery.

OPERATIONAL CYCLE

The PKHT24 operational cycle has a total cycle time of 2 minutes (120 seconds). The Timing Diagram and the steps listed below detail the individual functions that are executed during each operational cycle.

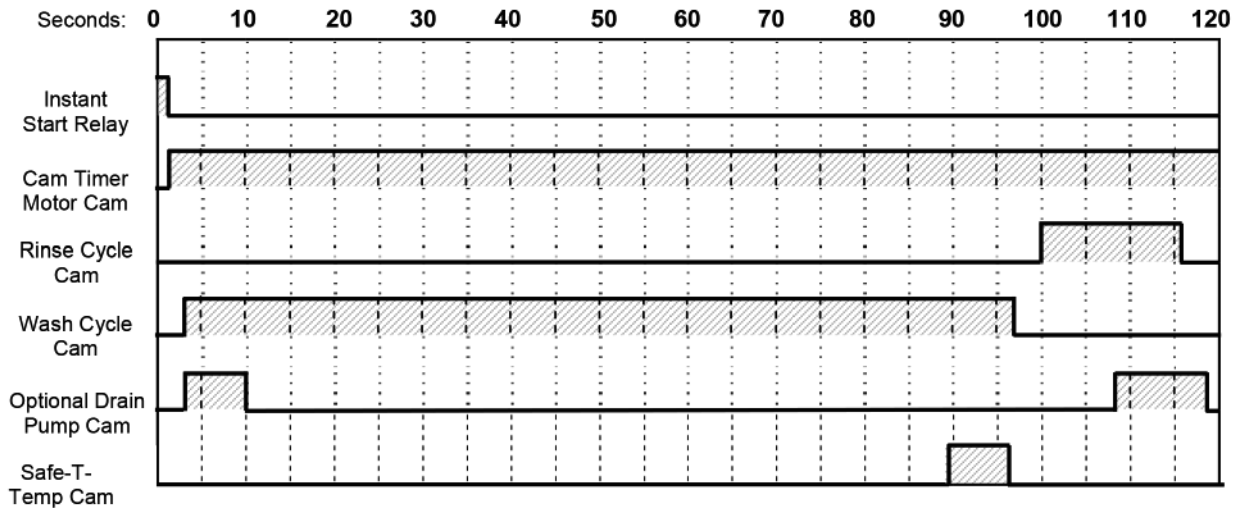

1. With the machine powered up, toggling the START switch begins a cycle.
 - a) Toggling the START switch energizes both the Cam Timer motor and the Instant Start Relay. The Instant Start Relay latches ON the power to the Cam Timer motor so that the START switch can be released a moment after it has been toggled without the Cam Timer motor losing power.
 - b) After about 1.5 seconds the Cam Timer's first cam — the Cam Timer Motor Cam — latches ON the power to the Cam Timer motor and drops out the Instant Start Relay. The Cam Timer motor continues to run for a total of 2 minutes, at which time it switches OFF — resetting the Cam Timer — and waits for the next START command.
2. The Cam Timer's third cam controls the Wash Pump. The Wash Pump comes ON about 3 seconds into the Operational Cycle and continues to run for 94 seconds. This 94-second period is the Wash Cycle.
3. At the same time that the Wash Pump comes ON the Cam Timer's fourth cam powers ON the Optional Drain Pump — if one is present — and keeps it running for about 7 seconds before powering OFF. This cam turns ON again midway through the Rinse Cycle and stays ON for 10 seconds, turning OFF 2 seconds after the Rinse Cycle has completed.
4. About 3 seconds after the Wash Cycle has completed the Cam Timer's second cam, which controls the Rinse Cycle, turns ON — energizing the Water Solenoid — and stays ON for 16 seconds. This 16-second period is the Rinse Cycle.
5. When the Cam Timer assembly approaches the final rinse portion of the cycle, the "Safe-T-Temp" sixth micro switch will pause Cam Timer assembly if the booster heater has not reached 180 degrees. The machine will remain in wash cycle mode until 180-degree rinse temperature is reached, and at this time the Cam Timer will advance automatically into the rinse cycle and dispense 180 degrees rinse water over the dishes.

GETTING STARTED

Receiving and Installation

The glasswasher is shipped from the factory in a corrugated box on a wooden pallet. The installation guidelines give a systematic procedure for setting up the machine.

Start by removing the packaging material. Unwrap the machine and check for the following component parts:

The Wash Tank Scrap Screen is shipped inside the wash cavity of the machine. This screen must be in place during operation. It has been designed to perform two basic functions:

1. Strain water that is circulating through the spray arms and pump assembly.
2. A basket to catch broken glass, or heavy solids that may plug the impeller.

Set the machine in place, and level from side-to-side and front-to-back.

Electrical¹

Single-phase 230 volt, 60 Hz dedicated circuit should be used to supply electrical energy to the PKHT24 Glasswasher (see specification sheet on page 4). This system requires three power wires, which include a current carrying neutral. An additional fourth wire must be provided for ground. Approximately 4-feet of $\frac{3}{4}$ " flexible conduit with power leads (L-1, L-2, Neutral and Ground) extending out of the conduit are provided for easily connecting the power at installation. The power connection must be located such that there is sufficient length of the flexible conduit remaining to permit the machine to be moved for cleaning.



**DO NOT USE POWER CORD
OR GFI OUTLET**

This unit **MUST BE** hard-wired to a dedicated appropriately sized circuit breaker.

Plumbing²

The machine is equipped with a 1/2" NPT connection located at the lower left-hand corner (facing the back) of the machine. A 140°F water line should be plumbed to this point (see specification sheet). The water line used must be of sufficient length and flexibility to permit the machine to be moved for cleaning.

^{1,2} All electrical and plumbing connections must be made by a qualified person who will comply with all available federal, state, and local health, electrical, plumbing and safety codes.

WARNING: If water pressure exceeds 50 psi, pressure reducing valve (PRV) is recommended. The supply water to the PKHT24 must be a minimum of 140°F at 24 psi (Pounds per Square Inch) with a 6 gpm (Gallons Per Minute) flow rate and 60 gph (Gallons Per Hour) recovery rate. The pipe supplying the water must be ½” minimum. The plumbing connection is located at the back of the machine. (See specification sheet on page 4).

The PKHT24 may be supplied with an optional drain pump for elevated drains. For floor gravity drain applications, the drain pump should not be used and a good commercial grade hose needs to be connected to the discharge side of the diverter valve (drain valve) and run to the floor drain. If a drain pump is used with a floor drain, the drain hose must rise 12 to 16” before dropping to the floor drain (to reduce any chance of the pump cavitations).

WARNING: Water hardness greater than 3 grains per gallon requires a water softener to prevent damage to heating elements (scale build- up) and booster tank rinse flow restriction. Rinse flow restriction will cause the booster tank to expand and contract causing metal flex, which will eventually crack the tank.

BETA Detergent And Rinse Dispenser

The built-in Beta Detergent and Rinse Dispenser has easy access for chemical settings behind the front kick panel. Both initial charge and recharge is factory pre-set. Basic settings for both detergent and rinse speed are 50%. Operating fine-adjustment screws on the dispenser can control the amount of chemicals drawn into chemical lines.

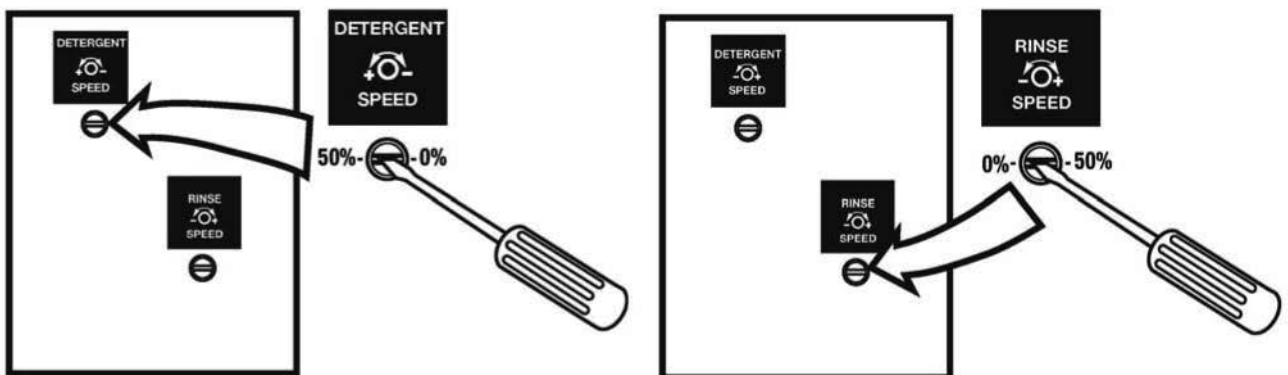

Safety-Temp Feature

The Safety-Temp feature assures the final rinse cycle is always at a consistent minimum of 180 degrees.

How it works: The Safety-Temp function operates off the fifth cam (labeled “SafeTemp”) on the timer assembly. When the cam timer assembly completes the wash cycle, and approaches the final rinse portion of the cycle, the Safety-Temp micro switch will drop into the cam slot and pause the cam timer assembly if the booster heater has not reached 180 degrees. The machine will remain in wash cycle mode until 180 degree rinse temperature is met, and at this time the cam timer will advance automatically into the rinse cycle and dispense 180 degrees rinse water over the dishes.

Note: If the Safety-Temp cam is not to be used, it becomes a spare cam.

Safety-Temp Installation Instructions

1. Remove the 4 cam timer assembly (note wire colors and wire placement for all 4 cam timer micro switches) and install the 5 cam timer in its place.
2. Place all wires removed from 4 cam timer assembly in the exact position on the 5 cam timer assembly.
3. The cam timer motor receives (1) yellow wire and (1) white wire (re-connect the yellow wire only from the glasswasher harness to the motor).
4. The Safety-Temp 5 cam timer assembly kit includes two white harnesses – connect the white wire with the female bullet connector to the timer motor, the stripped end to the #22/NC on the contactor, and the spade end to the center terminal on the fifth micro switch.
5. Connect white wire with male bullet connector from the kit to the white wire with female bullet connector coming from glasswasher harness, stripped end to #21/NC on contactor, and the spade end to the top terminal on the fifth micro switch.

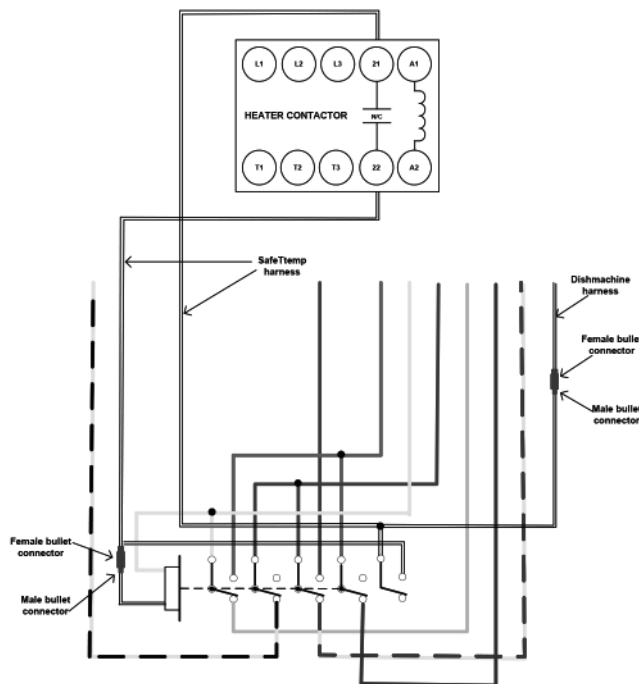

Booster Heater Setup

The booster tank must be filled with water before the heating element is energized. For this reason, the “High Limit Switch” has intentionally been disconnected at the factory and will require re-connection before the heating element will turn on.

Follow the procedure below to complete the initial installation:

1. Close the door on the machine.
2. Turn the Power switch to the “ON” position.
3. Hold the “FILL” switch in until water overflows into the scrap tray.
4. Turn the Power switch to the “OFF” position.
5. Connect the blue wire with the disconnect, identified by a red tag, to the High Limit Switch, which is located behind the thermostat behind the front kick panel.

Installer Checklist

- Glasswasher checked for concealed damage
- Hot water supply is 140° F (60 C) — minimum
- Incoming water supply line is ½” — minimum
- Incoming water supply is 6 GPM minimum at 24 psi
- Supply circuit breaker for machine is properly sized (50 amp)
- Service voltage and phase type are correct to machine data plate
- If drain pump is used, drain hose rises 12 to 16” before dropping to drain
- Drain hose is installed with air gap (discharge 1” above drain)
- Glasswasher is properly grounded
- Glasswasher is properly leveled
- Machine circuit breaker is labeled “GLASSWASHER”
- Machine has been “hard-wired” with correctly sized wire
- Booster tank has been filled with water (before High Limit Switch is reset)
- High Limit Switch for heater has been reset (after Booster Tank has been filled)

OPERATION

Initial Setup

Dema Flow Disc

The Dema Flow Disc has been placed on the exit side of the water valve. The Flow Disc reduces pressure to the standard recommended 20 psi.

Rinse and Wash Temperatures

1. Turn the Power switch to the "ON" position.
2. After the machine has warmed up for about ten minutes, note the wash and rinse temperatures. The wash temperature must be 155°F minimum. The rinse temperature must be 180°F minimum. If necessary, adjust the temperatures by removing the front kick panel and turning the thermostat adjustment clockwise to increase, or counterclockwise to decrease. This one adjustment controls both temperatures.

Post Instructions

1. Install wall chart and instruct machine operator on proper cleaning and operation of the PKHT24.

Startup Procedures

1. Open the door of the machine and check that the scrap screen is in place, and that the spray arms and end plugs are secure.
2. Close the door of the machine and turn the Power switch to the "ON" position.
3. Hold the fill button about 25 seconds or until the water overflows into the scrap tray.
4. Once the water is filled to the proper level, press the rocker switch marked "START" – the machine will automatically begin its cycle.
5. Check the machine's operating temperatures and adjust if necessary. See the Rinse and Wash Temperatures section above.
6. At the end of the wash period, drain the machine by pushing the rocker switch marked "DRAIN". Clean the wash tank screen and scrap tray screen. Remove and clean the spray arms. (See wall chart instructions).



OPERATING AND CLEANING INSTRUCTIONS FOR MODEL PKHT24

INSTRUCCIONES DE LIMPIEZA Y OPERACION DE MODELO PKHT24



1 Drain machine, press and hold drain button until water is completely drained out of the machine.
Para vaciar la maquina: Oprima el boton de vaciado y mantengalo apretado, hasta vaciar completamente el agua de la maquina.

2 Turn off power.
Apague la maquina

3 If spray arms are clogged remove by turning bearings counter clockwise.
Si los brazos de rociado se tapan, es necesario sacarlos desenroscandolos para el lado izquierdo.

4 Inspect top and bottom spray arm jets daily. Use toothpick and push trash into spray arm. Remove end plugs and flush with water.
Use un picadientes (palillo) para abrir los orificios. Destapar por las puntas, removiendo el tapon y enjuagelos con agua.

5 Hand remove and thoroughly clean filter, scrap screen and scrap basket under faucet or pre-rinse hose every shift.
Remueva el filtro de el interior de el tanque de desperdicios. Lave el filtro y los dos cedazos con el rociador de agua cada turno.

6 Replace all (3) screens back into position.
Reinstale el filtro y los dos cedazos apropiadamente.

7 Turn on power.
Prenda la maquina.

8 Push and hold fill button until water starts to overflow into scrap trap.
Mantenga apretado el boton de llenado hasta que vea el agua entrar al drenaje.

9 Start machine by pushing start button.
Para empezar la maquina, cierre la puerta y oprima el boton de encendido.

150° °F

WASH TEMP 150°-160°

CAUTION: DO NOT START until wash temperature reads 150°.
No empiece el lavado hasta que la temperatura sea 150°.



PREVENTIVE MAINTENANCE FOR MODEL PKHT24



1 If rinse arm jets are clogged, remove rinse arm (by turning bearing counter clockwise) and clean out rinse jets with paper clip or small pointed object.



2 Inspect top and bottom spray arms daily. Use toothpick to push debris into spray arm. Remove end plugs and flush with water.

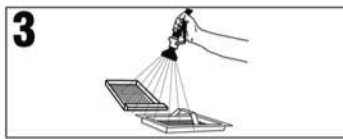

3 Remove and thoroughly clean scrap tray, and scrap drawer daily.

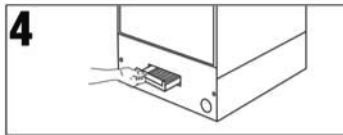

4 Replace screens after cleaning.

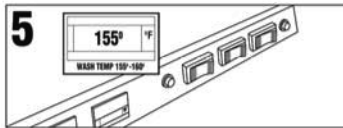

5 Confirm wash temperature is 155°F.

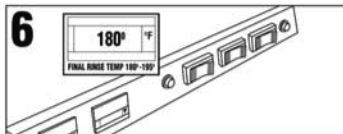

6 Check rinse temperature. Minimum 180°F. Notify supervisor if rinse temperature is below 180°F.

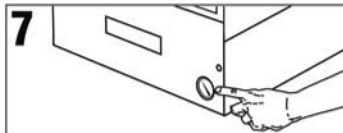

7 Check rinse pressure. Should be 15-22 psi.



8 Check chemical containers for product. Confirm correct product line is in the bucket.
RED - Detergent
BLUE - Rinse Aid



9 Check machine for leaks.

Quick Service Guide

TECHNICAL ISSUE	CAUSE	SOLUTION
Door leaks	Machine is not level or is leaning forward	Adjust machine legs to level
	Wash arm end cap is missing	Replace end cap
	Door gasket issue	Replace gasket
Thermometer failure	Loose wire at display, board or transformer	Secure connectors
	Faulty temperature sensing wire	Correct, replace
	Faulty temperature sending unit	Replace unit
	Scaled heating element	Clean scale from heater
Rinse water temperature too low/high	Booster heater's thermostat not properly set	Adjust thermostat
	Incoming water temperature to booster heater below 140 F	Adjust external water heater in the facility
Pump motor not running	Loose lead connections	Check and crimp connectors
	Faulty #3 micro switch	Replace micro switch
	Faulty contactor	Replace contactor
	Faulty wash pump motor	Replace wash pump motor
Pump motor runs continuously	Faulty #3 micro switch	Replace micro switch
	Faulty contactor	Replace contactor
Low water pressure in the final rinse	Water regulator not adjusted properly	Adjust regulator to 18-20 psi
	Clogged final rinse spray jets	Clean jets
	Missing final rinse spray end cap	Replace end cap
	Low incoming water pressure from facility	Increase pressure to 18-20 psi
Scrap trap overflows overnight	Faulty water solenoid diaphragm	Clean or replace diaphragm
Poor cleaning results	Low wash or rinse water temperature	Check temperature settings
	Wash arm bearing or jets	Clean bearing and arm jets
	Rinse arm bearing or jets	Clean bearing and arm jets
	Tank discharge screen dirty	Clean screen
Wash tank will not drain	Drain valve not operating	Check power to drain valve
	Drain valve faulty	Replace drain valve

Troubleshooting

TECHNICAL ISSUE	CAUSE	SOLUTION
Machine inoperative	Power off at circuit breaker	Reset circuit breaker
	Defective power switch	Replace power switch
Motor inoperative	Door is open	Close door
	Control panel is pulled out	Secure control panel
	Defective reed switch	Replace reed switch
	Defective timer assembly	Replace timer assembly*
	Defective pump motor contactor	Replace contactor
	Defective motor	Replace motor
Motor runs with door open	Defective reed switch	Replace reed switch
	Defective pump motor contactor	Replace contactor
Heater - No heat	High limit switch opened or defective	Reset or replace switch
	Defective thermostat	Replace thermostat
	Defective heater contactor	Replace heater contactor
	Defective heater	Replace heater
Heater - Keeps running	Defective thermostat	Replace thermostat
	Defective heater contactor	Replace heater contactor
Low heat during operation	Low incoming water temperature (below 140 F)	Turn up supply water heater or insulate supply water pipe
	Thermostat out of adjustment	Adjust thermostat
	Cold water mixing with supply	Isolate hot water from cold water
	Defective heater	Replace heater
Low rinse water pressure	Pressure regulator out of adjustment	Adjust pressure regulator
	Defective pressure gauge (actual pressure is fine)	Replace pressure gauge
Regulator at maximum but rinse pressure still low	Insufficient water supply	Supply larger supply line
	Defective water solenoid valve	Replace water solenoid valve
Low rinse water flow	Low rinse water pressure	See "Low rinse water pressure" in TECHNICAL ISSUE column
	Rinse arm spray nozzles are limed	De-lime rinse arm spray nozzles
No rinse water flow	Defective water solenoid valve	Replace water solenoid valve
	Defective (Rinse Relay) ice cube relay	Replace ice cube relay
Rinse water runs with door open	Defective reed switch	Replace reed switch

* The timer assembly motor or micro switches can be replaced independently if those are the only components that have failed.

Troubleshooting

TECHNICAL ISSUE	CAUSE	SOLUTION
With power on, activating start switch does not begin cycle	Defective start switch (cycle light will not light either)	Replace start switch
	Defective timer assembly	Replace timer assembly*
Start switch requires > 1 second activation to run cycle	Defective (Instant Start) ice cube relay	Replace ice cube relay
Activating fill switch does not fill machine	Defective drain/fill switch	Replace drain/fill switch
	Defective water solenoid valve	Replace water solenoid valve
Fill (rinse water) won't shut off	Defective water solenoid valve	Replace water solenoid valve
	Defective drain/fill switch	Replace drain/fill switch
	Defective timer assembly	Replace timer assembly*
	Defective (Rinse Relay) ice cube relay	Replace ice cube relay
Activating drain switch does not drain machine	Drain hose is kinked	Un-kink drain hose
	Defective drain/fill switch	Replace drain/fill
Cycle light does not light while cycle runs	Defective cycle light	Replace cycle light (green)
Power light does not light but machine runs	Defective power light	Replace power light (red)
Wash tank or final rinse temperature does not display	Defective digital thermometer	Replace digital thermometer
Both the wash tank temperature and the final rinse temperature do not display	Defective thermometer transformer	Replace thermometer transformer
Wash tank or final rinse displays wrong temperature	Defective digital thermometer	Replace digital thermometer
	Defective thermister	Replace thermister

* The timer assembly motor or micro switches can be replaced independently if those are the only components that have failed.

PARTS KIT
Parts Kit

P/N	DESCRIPTION	Qty
15504.00	Motor Contactor, 2-Pole 20 Amp	1
15504.50	Heater Contactor, 2-Pole 35 Amp	1
00501.00	2-Minute Timer Motor	1
00631.00	Ice Cube Relay 120 V	1
00707.00	½ Water Solenoid Repair Kit JE	1
00738.15	Solenoid Coil JE 220V	1
15523.00	Rocker Switch Start Momentary	1
15523.50	Rocker Switch Drain/Fill	1
15524.00	Rocker Switch Power Maintained	1
00556.10	Reed Switch	1
03623.00	1/2" Vacuum Breaker Repair Kit – Watts	1
00707.00	1/2" Water Solenoid Repair Kit – J/E	1
04113.00	L1X/L1-C Drain Valve 120V	1
00206.70	Pump Seal Kit	1
13417.89	Heater Thermostat	1
17523.60	High Limit Switch 200°F	1
00411.00	Microswitch	1
03203.01	Dual Temperature Display Kit	1
00738.15	Solenoid Coil JE 115V/60Hz	1

CUSTOMER NOTICE

PKHT24 Installation Guidelines

Improper installation of this product may void the warranty on this machine. Please follow these guidelines for recommended installation and to ensure the warranty of this model is applicable.

Glasswasher Installation Requirements

1. Machine must be level. Adjust leveling feet to accommodate uneven floor surfaces.
2. Drain height should not exceed maximum height of 16". Connect supplied drain line to three-way valve on back of machine and gravity feed to the floor drain.
3. Check the pressure. Recommended pressure is between 18-20 psi.
4. Water supply to machine must be a minimum 110°F.
5. A four-wire, (neutral, ground and two 110v lines) 220v single phase connection is required. There is a six-foot cord provided with the machine. We recommend a minimum 50-amp dedicated circuit, but you should consult your local building code requirements for proper breaker size.

Activating/Adjusting the Booster Heater

1. Booster heater must be filled with water prior to connecting the blue wire from high limit switch. The high limit switch can be found by removing the front panel and locating the red button on the front of the heater tank.
2. Once the booster heater has been connected, the thermostat should be adjusted to maintain 180°F during the final rinse cycle. The thermostat is located on the front of the booster tank and is accessible by removing the front panel on the machine.

Automatic Dispensing Equipment

1. Applications utilizing automated dispensers for administering ware wash chemicals must use 110v dispenser equipment. There is a 110v power block for installing this equipment inside the control panel.

Electrical Diagram

**PKHT24 ELECTRICAL DIAGRAM
CONTROL PANEL**

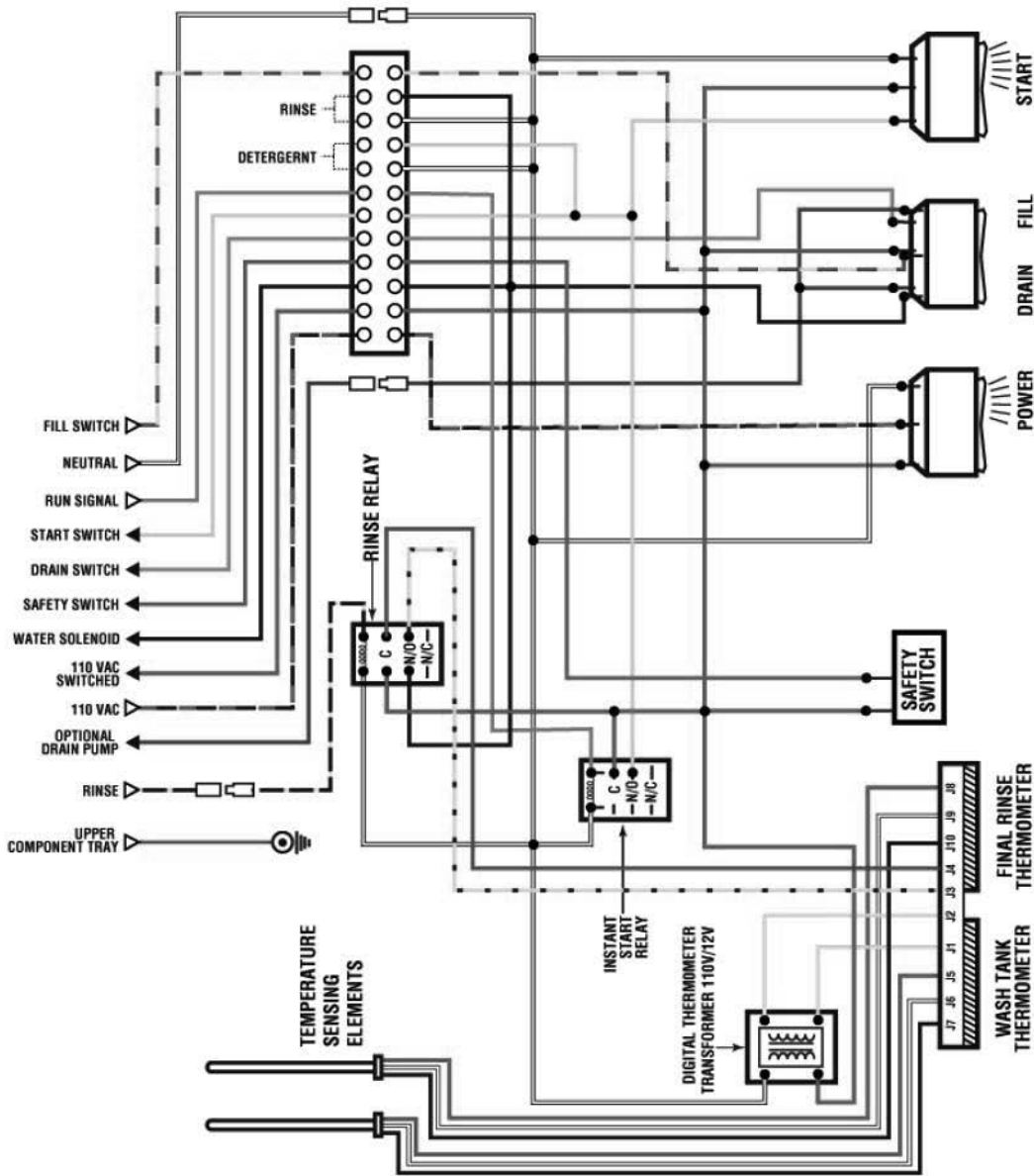

Electrical Diagram

PKHT24 ELECTRICAL DIAGRAM POWER BOX

