

APPLICARE
TARGA
CARATTERISTICHE

INSTRUCTIONS - HANDBOOK

191 SP/USA

*We wish to thank you for the preference granted to us by purchasing one of **CARPIGIANI** machines.*

*To the best guarantee, since 1993 **CARPIGIANI** has submitted its own Quality System to the certification according to the international Standard ISO 9001, nowadays its production has got UNI-EN-ISO 9001-2008 Certified Quality System.*

Moreover, Carpigiani machines comply with following European Directives:

- “Machinery” Directive 2006/42/EC,
- “Low Voltage” Directive 2006/95/EC,
- “EMC” Directive 2004/108/EC,
- “PED” Directive 97/23/EC,
- Regulation 2004/1935/EC relating to “Materials and articles in contact with foodstuffs”

CARPIGIANI

Via Emilia, 45 - 40011 Anzola dell'Emilia (Bologna) - Italy

Tel. +39 051 6505111 - Fax +39 051 732178

This manual contains a TRANSLATION OF THE ORIGINAL INSTRUCTIONS and may not be reproduced, transmitted, transcribed, filed in a data retrieval system or translated into other languages, without the prior written permission of **CARPIGIANI**.

The purchaser has the right to reprint it for his own office use.

CARPIGIANI policy pursues a steady research and development, thus it reserves the right to make changes and revisions whenever deemed necessary and without being bound to previous statements to the purchaser.

Issue: 3	Date: 2012/09	Changes:
Issued by: AM	Checked by: RF	Approved by: RV

INDEX

FOREWORD	5
INSTRUCTION HANDBOOK	5
PURPOSE	5
HANDBOOK STRUCTURE	5
ADDITIONAL DOCUMENTATION	5
CONVENTIONAL SYMBOLS	6
SYMBOLOLOGY QUALIFICATION OF THE STAFF	6
SAFETY.....	7
WARNING.....	7

SECT. 1 GENERAL

1.1 GENERAL INFORMATION	9
1.1.1 MANUFACTURER'S IDENTIFICATION DATA.....	9
1.1.2 INFORMATION ABOUT SERVICE.....	9
1.1.3 INFORMATION TO THE USERS	9
1.2 INFORMATION ABOUT THE MACHINE	9
1.2.1 GENERAL DATA.....	9
1.2.2 MACHINE LAY-OUT.....	10
1.2.3 TECHNICAL FEATURES	10
1.2.4 MACHINE SETS LOCATION	11
1.3 INTENDED USE	11
1.4 NOISE	11
1.5 STORING A MACHINE	11
1.6 DISPOSAL OF PACKING STUFFS	11
1.7 WEEE	11

SECT. 2 INSTALLATION

2.1 ROOM NECESSARY TO THE MACHINE USE	13
2.2 MACHINE WITH AIRCOOLED CONDENSER	13
2.3 MACHINE WITH WATERCOOLED CONDENSER	14
2.3.1 WATER VALVE ADJUSTMENT.....	14
2.4 ELECTRIC CONNECTION	14
2.4.1 REPLACEMENT OF POWER SUPPLY CORD.....	14
2.5 REFILLING	14
2.6 MACHINE TESTING	14

SECT. 3 DIRECTION FOR USE

3.1 MACHINE CONFIGURATION	15
3.2 ELECTRONIC CONTROL KEYBOARD AND BUTTON FUNCTION	15
3.3 SPIGOT HANDLE	17
3.4 "R" PUMP	17
3.5 PRELIMINARY OPERATION, WASHING AND SANITIZATION	18
3.6 STARTING THE MACHINE	18
3.7 PRODUCTION	18
3.8 PASTEURIZATION	19
3.9 OPENING PROCEDURES	19
3.9.1 SANITIZATION OF THE LID AREA.....	19
3.9.2 DISASSEMBLY AND CLEANING OF COMPONENTS.....	19
3.9.3 REASSEMBLY OF COMPONENTS	19
3.9.4 EXTERNAL CLEANING OF THE MACHINE	20
3.10 CLOSING PROCEDURES	20
3.10.1 PRE-ARRANGE THE MACHINE FOR A PASTEURISATION CYCLE OVERNIGHT.....	20
3.10.2 DISASSEMBLY AND CLEANING OF THE TANK COVER	20
3.10.3 CLEANING THE TANK ZONE.....	20

3.10.4	DISASSEMBLY AND CLEANING THE OIL DRIP DRAWERS.....	20
3.10.5	SANITIZATION OF THE LID AREA.....	20
3.10.6	CLEANING AND SANITISATION OF THE OIL DRIP TRAY	20
3.10.7	EXTERNAL CLEANING OF THE MACHINE	20

SECT. 4 SAFETY DEVICES

4.1	ALARMS	21
4.1.1	BLACK-OUT	22

SECT. 5 CLEANOUT DISASSEMBLING AND REASSEMBLING OF PARTS IN CONTACT WITH THE PRODUCT

5.1	GENERAL DESCRIPTION	23
5.2	WASHING CONDITIONS	23
5.3	SUGGESTIONS.....	23
5.4	HOW TO USE DETERGENT/SANITIZER.....	24
5.5	DAILY CLEANING.....	24
5.6	PROGRAMMED CLEANING TIME	24
5.7	DRAINING AND CLEANING.....	24
5.8	DISASSEMBLING OF THE TANK MIXER	25
5.9	DISASSEMBLING MIX PUMP.....	25
5.10	DISASSEMBLING OF THE DISPENSING DOOR.....	26
5.11	DISASSEMBLING OF THE BEATER	26
5.12	WASHING AND SANITIZING OF COMPONENT PARTS	27
5.13	REASSEMBLING OF THE HOPPER MIXER.....	27
5.14	REASSEMBLING MIX PUMP.....	28
5.15	REASSEMBLING OF THE BEATER	29
5.16	REASSEMBLING OF THE DISPENSING DOOR	29
5.17	SANITIZING THE WHOLE MACHINE.....	30
5.18	MIX PRIMING	30

SECT. 6 MAINTENANCE

6.1	SERVICING TYPOLOGY	31
6.2	WATERCOOLING.....	32
6.3	AIRCOOLING.....	32
6.4	TABLE OF SPARE PARTS EQUIPMENT.....	33

SECT. 7 TROUBLESHOOT GUIDE

7.1	TROUBLESHOOT GUIDE.....	35
-----	-------------------------	----

FOREWORD

INSTRUCTION HANDBOOK

Editing this handbook, it was taken into due account European Community directions on safety standards as well as on free circulation of industrial products within E.C.

PURPOSE

This handbook was conceived taking machine users' needs into due account. Topics relevant to a correct use of the machine have been analyzed in order to keep unchanged in the long run quality features characterizing **CARPIGIANI** machines all over the world. A significant part of this handbook refers to the conditions necessary to the machine use and to the necessary procedure during cleanout as well as routine and special maintenance. Nevertheless, this handbook cannot meet all demands in details. In case of doubts or missing information, please apply to:

CARPIGIANI Via Emilia, 45 - 40011 Anzola dell'Emilia (Bologna) - Italy
Tel. +39 051 6505111 - Fax +39 051 732178

HANDBOOK STRUCTURE

This handbook is divided in sections, chapters and subchapters in order to be consulted more easily.

Section

A section is the part of the handbook identifying a specific topic related to a machine part.

Chapter

A chapter is that part of a section describing an assembly or concept relevant to a machine part.

Subchapter

It is that part of a chapter detailing the specific component of a machine part.

It is necessary that each person involved in the machine operation reads and clearly understands those parts of the handbook of his/her own concern, and particularly:

- The Operator must read the chapters concerning the machine start-up and the operation of machine components.
- A skilled technician involved in the installation, maintenance, repair, etc., of the machine must read all parts of this handbook.

ADDITIONAL DOCUMENTATION

Along with an instruction manual, each machine is supplied also with additional documentation:

- **Part list:** A list of spare parts which is delivered together with the machine for its maintenance.
- **Wiring diagram:** A diagram of wiring connections is placed in the machine.

**Before using the machine read carefully the instruction handbook.
Pay attention to the safety instructions.**



CONVENTIONAL SYMBOLS



CAUTION: ELECTRIC SHOCK DANGER

The staff involved is warned that the non-observance of safety rules in carrying out the operation described may cause an electric shock.



CAUTION DANGER FROM HIGH TEMPERATURES

This warns the staff involved that failure to abide by safety rules in carrying out the operation described involves the risk of burns and scalds.



WARNING DANGER FROM MOVING PARTS

This informs the staff concerned of the presence of moving parts and the risk of injury from failure to comply with safety regulations.



CAUTION CRUSHING HAZARD

This warns the staff involved that failure to abide by safety rules in carrying out the operation described involves the risk of suffering crushed fingers or hands.



CAUTION: GENERAL HAZARD

The staff involved is warned that the operation described may cause injury if not performed following safety rules.



NOTE

It points out significant information for the staff involved.



WARNINGS

The staff involved is warned that the non-observance of warning may cause loss of data and damage to the machine.



PROTECTIONS

This symbol on the side means that the operator must use personal protection against an implicit risk of accident.

SYMBOLGY QUALIFICATION OF THE STAFF

The staff allowed to operate the machine can be differentiated by the level of preparation and responsibility in:



MACHINE OPERATOR

Identify unqualified personnel, those without any specific technical abilities who are capable of carrying out simple jobs, such as: operating the machine using the commands available on the keypad, the loading and unloading of products used during production, the loading of any consumable materials, basic maintenance operations, (cleaning, simple blockages, controls of the instrumentation, etc.).



MAINTENANCE ENGINEER

He/she is a skilled engineer for the operation of the machine under normal conditions; he/she is able to carry out interventions on mechanical parts and all adjustments, as well as maintenance and repairs. He/she is qualified for interventions on electrical and refrigeration components.



CARPIGIANI ENGINEER

He/she is a skilled engineer the manufacturer assigned to field interventions for complex jobs under particular conditions or in accordance with agreements made with the machine's owner.

SAFETY

When using industrial equipment and plants, one must be aware of the fact that drive mechanisms (rotary motion), high voltage components, as well as parts subject to high temperatures may cause serious damage to persons and things.

Who is in charge of plant safety must be on the look-out that:

- an incorrect use or handling shall be avoided;
- safety devices must neither be removed nor tampered with;
- the machine shall be regularly serviced;
- only original spare parts are to be used especially as far as those components with safety functions are concerned (ex.: protection microswitches, thermostats);
- suitable personal protective equipment is worn;
- high care must be paid during hot product cycling.

To achieve the above, the following is necessary:

- at the working place an instruction manual relevant to the machine should be available;
- such documentation must be carefully read and requirements must consequently be met;
- only adequately skilled personnel should be assigned to electrical equipment;

IMPORTANT!

One must be on the look-out that the staff does not carry out any operation outside its own sphere of knowledge and responsibility (refer to "Symbology qualification of the staff").

NOTE:

According to the standard at present in force, a SKILLED ENGINEER is who, thanks to:

- training, experience and education,

- knowledge of rules, prescriptions and interventions on accident prevention,

- knowledge of machine operating conditions,

is able to realize and avoid any danger and has also been allowed by the person in charge of plant safety to carry out all kinds of interventions.

WARNING

When installing the machine, insert a differential magnetothermal protection switch on all poles of the line, adequately sized to the absorption power shown on machine data plate and with contact opening of 3 mm at least.

- Never put your hand into the machine, alike during production and cleaning operations. Before carrying out any maintenance operation, make sure that the machine is in "STOP" position and main switch has been cut out.
- It is forbidden to wash the machine by means of a bolt of water under pressure.
- It is forbidden to remove panels in order to reach the machine inside before having disconnected the machine.
- **CARPIGANI** is not responsible for any accident that might happen during operation, cleaning and/or servicing of its units, if this warning has not been fully complied with.



1. GENERAL INFORMATION

1.1 GENERAL INFORMATION

1.1.1 Manufacturer's identification data

The machine has a data plate carrying manufacturer data, machine type and serial number, assigned when it is manufactured.

Copy of machine data plate to be found on first page of this handbook.

MODEL NO. _____			
SERIAL NO. _____		DATE _____	
VOLT _____		PHASE _____ HZ _____	
MAX. BREAKER/FUSE SIZE _____ AMP			
MINIMUM CIRCUIT RATING _____			
		DESIGN PRES.	OPERATING PRES.
HIGH SIDE PSIG			
LOW SIDE PSIG			
REFRIGERANT _____ AMOUNT _____ OZ			
	BEATER	COMPRESSOR	FAN
QTY			
HP			
FLA			
LRA			

1.1.2 Information about service

All operations of routine maintenance are here described in section "Maintenance"; any additional operation requiring technical intervention on the machine must be cleared with the manufacturer, who will also examine the possibility of a factory technician field intervention.

1.1.3 Information to the user

- The manufacturer of the machine is at user's disposal for any explanation and information about the machine operation.
- In case of need, please call the local distributor, or the manufacturer if no distributor is available.
- Manufacturer's service department is available for any information about operation, and requests of spare parts and service.



1.2 INFORMATION ABOUT THE MACHINE

1.2.1 General data

Counter-top machine to immediately produce and distribute soft express ice cream in one flavor available with pump to ensure a greater increase of volume.

CARPIGIANI recommends to always use high quality mix for ice cream production in order to satisfy your customers, even the most hard-to-please ones. Any saving made to the prejudice of quality will surely turn into a loss much bigger than the saving itself.

Bearing in mind the above statements, please take heed of the following suggestions:

- Make your mixes yourselves from high quality natural ingredients or buy them from reliable companies.
- Follow closely instructions given by your mix supplier for the preparation of the mixes.
- Do not alter your mix supplier's recipes, by adding, for instance, water or sugar.
- Taste ice cream before serving it and start selling it only if entirely satisfactory.
- Make sure your staff always keeps the machine clean.
- Have your machine serviced always by companies authorized by **CARPIGANI**.

1.2.2 Machine layout

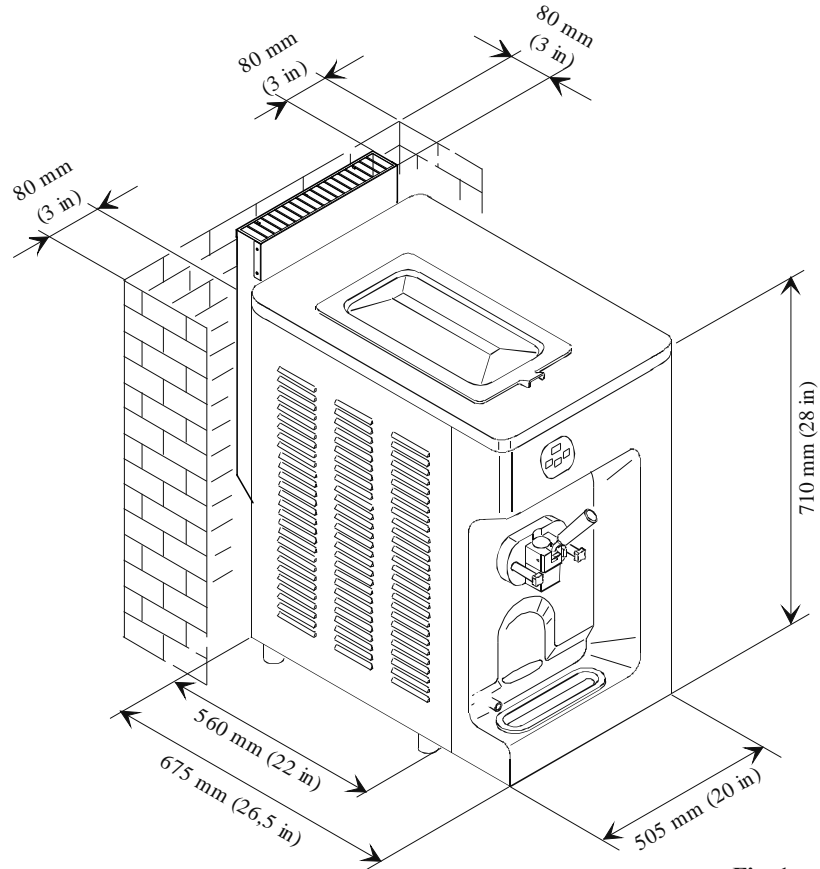

Fig. 1

1.2.3 Technical features

MODEL	Hourly production * 120 ml - 0,03 gal portions	Hopper capacity liters/gal	Flavors	Electrical supply			Installed power kW/Hp	Net weight Kg/lb
				Volt	Phase	Cycle		
191 P/SPN	250	12	1	380	3	60	2,1	143

* Hour output may vary depending on mix used
Performances featured by a room temperature of 25°C and a water temperature of 20°C.

1.2.4 Machine sets location

Caption:

- 1 Control panel
- 2 Freezing cylinder front lid
- 3 Drip tray shelf
- 4 Mix tank cover
- 5 Oil drip drawer

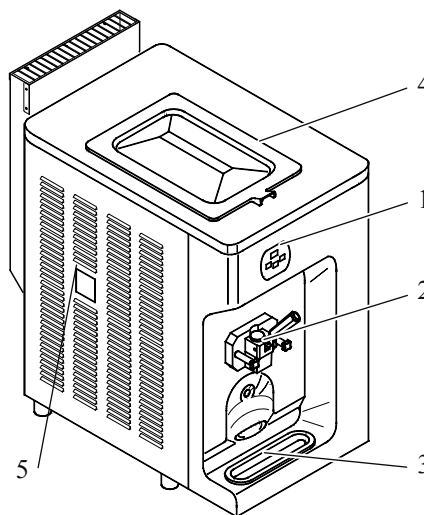

Fig. 2

1.3 INTENDED USE

The machines must be used solely for the purpose described in chapter 1.2.1, "General information" within the functional limits described below.

Voltage:	±10%
Min air temperature °C:	10°C
Max air temperature °C:	43°C
Min water temperature:	10°C
Max water temperature:	30°C
Min. water pressure:	0,1 MPa (1 bar)
Max water pressure:	0,8 MPa (8 bar)
Max relative humidity:	85%

The machine has been designed for its use in places which are not subject to explosion-proof standards; its use is thus bound to conforming places and normal atmosphere.

1.4 NOISE

The steady acoustic pressure level weighed A in a working place alike by watercooled and by aircooled machines is less than 70 dB(A).

1.5 STORING A MACHINE

The machine must be stored in a dry and dust-free place.
Before storing the machine, wrap it in a cloth in order to protect it against dust and else.

1.6 DISPOSAL OF PACKING STUFFS

When opening the packing crate, divide packing stuffs per type and get rid of them according to laws in force in machine installation country.

1.7 WEEE (Waste Electrical and Electronic Equipment)

In conformity with the European Directives 2006/66/EC, on batteries and accumulators and waste batteries and accumulators, and 2002/96/EC, also known as WEEE, the presence of the symbol on the side of the product or packaging means that the product must not be disposed of with normal urban waste. Instead, it is the user's responsibility to dispose of this product by returning it to a collection point designated for the recycling/treatment of electrical and electronic equipment waste. Differentiated collection of this waste material helps to optimize the recovery and recycling of any reclaimable materials and also reduces the impact on human health and the environment. For more information concerning the correct disposal of this product, please contact your local authority or the retailer where this product was purchased.



2. INSTALLATION

2.1 ROOM NECESSARY TO THE MACHINE USE

The machine must be installed in such a way that air can freely circulate allaround. Rooms for the approach to the machine must be left free in order to enable the operator to act without constraint and also to immediately leave working area, if need be.

ATTENTION

Machines with aircooled condenser must be installed no closer than 8 cm to any wall in order to allow free air circulation around the condenser.

NOTE

An insufficient air circulation affects operation and output capacity of the machine.

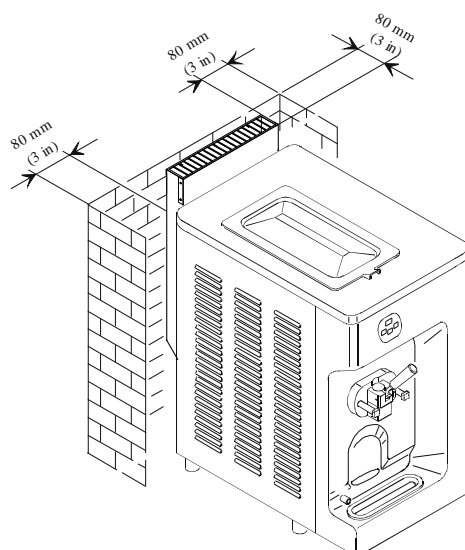

Fig. 3

2.2 MACHINE WITH AIRCOOLED CONDENSER

Machines with aircooled condenser must be installed no closer than 8 cm to any wall in order to allow free air circulation around the condenser.

NOTE

An insufficient air circulation affects operation and output capacity of the machine.





2.3 MACHINES WITH WATERCOOLED CONDENSER

To make the machine run, a watercooled machine must be connected to running water supply, or to a cooling tower. Water must have a pressure of 1 Bar at least and a delivery at least equal to the estimated hourly consumption. Connect inlet pipe marked by plate "Water Inlet" to water supply installing a shut-off valve, and outlet pipe marked by plate "Water Outlet" to a drain pipe, installing a shut-off valve.

2.3.1 Water valve adjustment

WARNING

If water valve must be retarded, this operation will have to be carried out by skilled personnel, only. Valve adjustment must be carried out in such a way that no water flows when machine is off and lukewarm water flows when machine is on.

NOTE:

Water consumption increases if temperature of entering water is above 20°C.

ATTENTION:

Do not leave the machine in a room with temperature below 0°C without first draining water from the condenser.

2.4 ELECTRIC CONNECTION

Before connecting the machine to the mains, check that machine voltage indicated in data plate corresponds with the mains (see sec. 1.1.1 point C).

Insert a differential magnetothermal protection switch adequately sized to absorption capacity required (see sec. 1.1.1 point D) and with contact opening of 3 mm at least.

WARNING

Yellow/green ground wire must be connected to a good ground outlet.

Rotation direction by three-phased machines

The beater rotates anticlockwise. By gravity-feed machines, it is necessary to remove the plate and check the direction of rotation, whereas by machines with pump you shall check whether the mix comes out from delivery hole when removing the compression pipe.

Reversing rotation direction

To reverse the direction rotation, when wrong, it is necessary to interchange two of the three leads coming from the circuit breaker.

2.4.1 Replacement of power supply cord

If the machine main cable is damaged, it must be replaced through a cable with similar features.

Replacement will have to be carried out by skilled technicians only.

2.5 REFILLING

Motor installed in the machine is of the type with lubrication for life; no action of checking/replacing or topping up is necessary.

Gas filling necessary to the freezing system is carried out at CARPIGIANI works during machine postproduction testing. If a gas addition happens to be made, this must be carried out by skilled technicians, only, who can also find out trouble origin.

2.6 MACHINE TESTING

A postproduction test of the machine is carried out at Carpigiani premises; Operation and output functionality of the machine are thoroughly tested. Machine test at end user's must be carried out by skilled technicians or by one of CARPIGIANI engineers. After the machine positioning and correct connections, also carry out all operations necessary to functional check and test of the machine.

3. DIRECTION FOR USE

3.1 MACHINE CONFIGURATION

The machine has a motor to drive the beater, and a cooling system with water or air condenser. **Soft ice cream is prepared by filling the tank with cold mix (+4°C) and starting the automatic production cycle, until the ideal ice cream consistency set by CARPIGIANI is reached.** Thanks to the pump or to the feeding needle, the mix enters the freezing cylinder already mixed with air; ice cream is produced only when it needs to be served. The spigot head allows a single portion of soft ice cream to be distributed. At the same time, the same amount of mix moves from the hopper into the freezing cylinder.

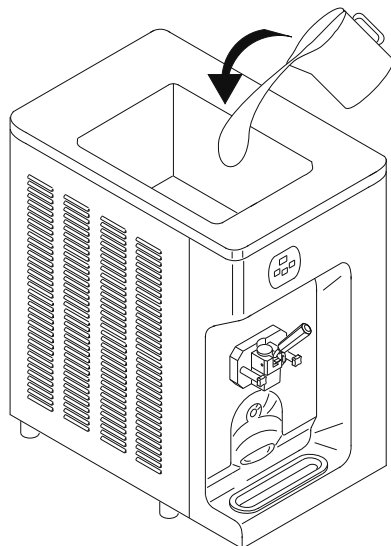

Fig. 5

3.2 ELECTRONIC CONTROL KEYBOARD AND BUTTON FUNCTIONS

Details of the panel are shown in the picture below.



Fig. 6

**STOP button**

STOP function selected and light indicator on: the machine is ready to receive all the functions.

From Production, Storage and Pasteurization it is necessary to press Stop 2 seconds, in order to have the machine in STOP and so avoid "touch" problems with the touch-sensitive panel.

**PRODUCTION function (Prd)**

When selecting this function the led lights up and the mix into the cylinder is freezed until its set consistency (pre-set HOT setting) is reached.

**CLEANING function (CLE)**

When selecting this function, led lights up, the beater and the mix pump run, while the refrigeration unit is off. This function is timed and ends automatically when the set time (usually 3 minutes) is reached.

**LOCK button**

To clean the keyboard panel with a clean towel it is recommended to block the keys of the keyboard as follows:

Push for 3 second the LOCK button, the respective led will flash indicating that the keyboard is blocked. At this stage you can clean the keyboard without any risk. To reactivate the keyboard push for 3 seconds the LOCK button, the led will get off.

**PASTEURIZING function (PAS)**

Pasteurization cycle will not start if the mix inside the hopper is below the minimum level. The mix, both in hopper and in cylinder, is heated up to 65°C, held at this temperature for 30 minutes, then cooled down to the storage temperature.

**STORAGE function (Sto)**

When selecting this function, led lights up and the machine stores the mix both in hopper and cylinder at a pre-set temperature of +4°C. The display indicates mix temperature in the hopper.

**MIX LEVEL INDICATOR**

On display you'll be able to see:

1. Mix Out
2. How many cup is as still possible to delivery (last cones)

3.3 SPIGOT HANDLE

In order to dispense the product, place a cup or a cone under the spout and slowly pull down the dispensing handle (pos. 5). As soon as the product comes out, twist the cup or the cone to form a cone-shaped serving. When the portion has reached the desired size, close the dispensing handle and quickly pull the cone or the cup down in order to sharpen the tip.

WARNING

It is important to keep the sensor (pos. 920) clean.

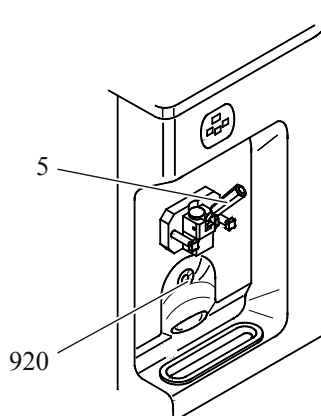

Fig. 7

3.4 "R" PUMP

"R" pump allows, by changing position of regulator pos. 271, to vary proportions between air and mix conveyed to the freezing cylinder; so, within certain limits, it allows overrun regulation depending on mix used.

"R" pump regulator should be set to the middle position.

If, after dispensing a significant number of cones, ice cream is too heavy and wet, you may move the R pump regulator a notch at a time towards the right. If ice cream comes out of spigot mixed with air bubbles, then turn R pump regulator a notch at a time towards the left.

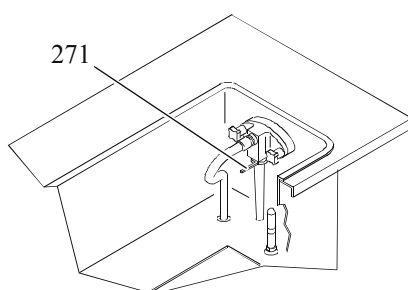

Fig. 8



3.5 PRELIMINARY OPERATIONS, WASHING AND SANITIZATION

Before starting the machine for the first time, it is necessary to thoroughly clean its parts and sanitize all parts coming into contact with the mix. To perform these operations see section 5 of this manual.

3.6 STARTING THE MACHINE

After installing the machine according to the instructions contained in the chapter **INSTALLATION**, and after carefully cleaning and sanitizing the machine, proceed as follows:

Remove the compression pipe from bottom of the tank and place it in the sanitizing solution.

Prime Hopper:

- Retrieve 1 bag of mix from the walk-in refrigerator.
NB.: Mix to be poured at a temperature of 4-5°C.
- With the draw handle open, pour one bag of mix into the hopper and allow the mix to pass also into the freezing cylinder. The mix level in the tank must never reach the pump (see photo) and more mix must be added when the level goes below approximately 2 cms from the tank bottom.
- When only a full strength mix is flowing from the draw spout, bringing with it eventual residues of sanitizer, close the draw handle.

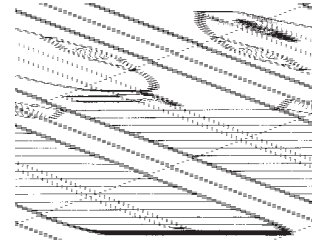

Fig. 16

Connect the mix pressure pipe:

- When the mix stops bubbling from the bottom of the hopper, take the mix pressure pipe from the sanitizing solution and insert it in its position in the bottom of the hopper. Make sure your hands are clean and sanitized.
- Rotate the compression tube in a clockwise direction towards the pump and connect it to the pump and rotate the connection tube (pos. 207) to block it. The level of the mixture in the vat must never reach the pump (see figure). It is also necessary to add mixture when the level has dropped to approximately 2 cms from the bottom.
- Reposition the vat cover.
- Select the production function.

3.7 PRODUCTION

Dispense icecream without exceeding the machine production rate as shown in the table on page 13. If you do not exceed it, and provide to refill the machine with fresh mix, you can be sure you will never have to stop selling, even during peak hours.

While your store is closed, set the machine to STORAGE mode.

You will save significantly on energy consumption, as the compressor runs only for the time strictly necessary in order to keep product at its correct temperature.

When you reopen the store, assure that the heat-treatment has been correctly completed and no malfunction has occurred, set the machine to STOP and then to PRODUCTION. Within a few minutes icecream will be back at the correct consistency for sale.

It is essential that you carry out CLEANING and SANITIZATION of the machine, every few days, depending on bacteriological quality of your mix as well as on health regulations in force in your country.

If the machine has been stopped a long time due to a power failure, it is necessary that you check product temperature before starting the sale again; if the temperature is over +6°C, the machine must be emptied, cleaned and sanitized, and filled up with new fresh mix at +4°C.



3.8 PASTEURIZATION

When you stop production, mix in tank and in cylinder must be pasteurized: to do that, press STOP and then SELECTION till the led relevant to PASTEURIZATION function switches on. The machine can also be programmed to carry out pasteurisation automatically whilst the premises are closed and on a time scale set in the programme of the machine (by the technician).

It is anyway necessary that the mix inside the tank is over the half of tank capacity (mean level should be thus covered).

The machine automatically executed heating and cooling programs and then stores the product at +4°C.

In the event of a black-out during the pasteurization cycle, the machine will automatically carry out the program. On reopening your shop, assure that the heat-treatment has been correctly completed and no malfunction has occurred, press STOP and then select the production function; within a few minutes ice cream will reach its right consistency to be served.

In the event of extended power failure, it is utmost necessary that, before dispensing ice cream again, the temperature of the mix inside the tank is checked, so as to pasteurize the mix in case it is beyond 6°C. If the power failure lasts several hours, it is then necessary to clean the machine and refill with fresh mix.



3.9 OPENING PROCEDURES

ATTENTION

Ensure that your hands are thoroughly clean and sanitized before proceeding with the following operations.

- Check that the Pasteurisation cycle has been totally completed and that the message “END” has appeared on the display. This message indicates that the pasteurisation process has been completed correctly without interruptions and the machine is ready for production. Press the Stop key and put the machine into production.

ATTENTION

If the Pasteurisation cycle has not been completed, the machine is blocked and access cannot be gained to production. The mix has not been correctly pasteurized.

Check why the pasteurization has not been carried out by reading the alarm messages on the display.

If necessary, contact Technical Assistance.

Press the Stop key and the arrow key to select the pasteurization function and carry out a manual pasteurization cycle. If the pasteurization cycle is completed successfully, the blockage automatically resets and the machine is ready to start production. No product can be dispensed during the pasteurization cycle.

3.9.1 Sanitization of the lid area

- Fill a bucket with detergent/sanitizing solution. Immerse the brush into the solution and accurately clean the dispenser zone, the dispenser spout, the handle and the area surrounding the piston; then rinse with clean water.
- Spray detergent/sanitizing solution over the tap zone, handle, dispenser spout and inside the lid hole; then rinse with clean water



ATTENTION

Do not spray sanitising solution directly onto the photocell underneath the door.

3.9.2 Disassembly and cleaning of components

Remove the oil drip tray, the oil drip drawers and the tank cover. Wash, sanitise and rinse them. Reassemble the components after sanitisation.



3.9.3 Reassembly of components

Reassemble the oil drip tray, the oil drip drawers and the tank cover after sanitization.



3.9.4 External cleaning of the machine

Using a clean and sanitised cloth, clean the door area, the front panel and any other areas that come into contact with the product.



3.10 CLOSING PROCEDURES

ATTENTION

Ensure that your hands are thoroughly clean and sanitized before proceeding with the following operations .



3.10.1 Pre-arrange the machine for a pasteurisation cycle overnight

- Open the lid and check the level of mix in the tank.
- Add mix if necessary. The LED of the tank level indicator must be off. The level of the mix in the tank must never reach the pump.
- Ensure that the machine is in Distribution mode (the relative LED must be alight).

3.10.2 Disassembly and cleaning of the tank cover

Disassemble the tank cover and wash, sanitise and rinse it.



3.10.3 Cleaning the tank zone

Using a clean and sanitized cloth, accurately clean the external zone of the tank. Ensure that no debris drops into the tank. Reposition the sanitized tank cover on the tank.



3.10.4 Disassembly and cleaning the oil drip drawers

Remove the two oil drip drawers from the side of the machine. Wash, sanitise, rinse and reassemble them.



3.10.5 Sanitization of the lid area

- Fill a bucket with detergent/sanitizing solution. Immerse the brush into the sanitising solution and accurately clean the dispenser zone, the dispenser spout, the handle and the area surrounding the piston.
- Spray sanitizing solution over the tap zone, handle, dispenser spout and inside the lid hole.
- Rinse with clean water



ATTENTION

Do not spray sanitising solution directly onto the photocell underneath the door.

3.10.6 Cleaning and sanitisation of the oil drip tray

After sanitising the door area, remove the oil drip tray and wash, sanitise and rinse it. Replace it on the machine.



3.10.7 External cleaning of the machine

Using a clean and sanitised cloth, clean the door area, the front panel and any other areas that come into contact with the product.



4. SAFETY DEVICES

4.1 ALARMS

The machine is provided with a self- “CHECK“ indicating possible troubles with your machine.

The “CHECK” led (**the spot down on the right side of the display**) blinks when an alarm is active, and it stays on as a reminder of an alarm occurred and reset.

When an alarm is displayed, check which one through the table below.

The machine can be used in the distribution mode also when an alarm has occurred, provided that it is non critical one; otherwise the machine will not allow to enter in the distribution function; if this is the case, press STOP and do not use the machine till its repair.

Press Selection in order to delete the writing with reset alarm.

In the table below you can find list of available alarms:

ALARM	DESCRIPTION
A01 (PTMA)	Thermal protection tripped.
A02 (RTC/PTMC)	Compressor thermal relay or Compressor thermal protection tripped.
A03 (TESV)	Tank Safety thermostat tripped.
A04 (TESC)	Cylinder Safety thermostat tripped.
A05 (TEV)	Tank sensor faulty (interrupted or under short circuit). You can only enter in Cleaning function. The machine set at Stop.

Above 5 critical alarms cause machine to set at STOP, while led blinks if the alarm is still active and is fixed on if reset.

ALARM	DESCRIPTION
A06 (TEC)	Cylinder sensor faulty (interrupted or under short circuit). If tripping comes from Pasteurization or Storage, the machine will set at Stop. If it comes instead from Cleaning or Production, the machine will remain in that function: relevant led blinks and A06 will be displayed.
A07 (TGV)	Tank evaporator sensor faulty (interrupted or under short circuit). The alarm will cause check led blinking but will not stop the machine (this remains in the same function).
A09 (IMS)	Safety magnet switch. Front lid open.
A11 (PRESS)	High pressure switch tripped. After 3 times or when it trips 2'consecutively, the machine sets at Stop.
A12 (TE1)	Cylinder evaporator sensor faulty (interrupted or under short circuit). The alarm will cause check led blinking but will not stop the machine (this remains in the same function).
A15 (BLACK OUT)	Blackout. The machine returns to the function where it was , excepted for Cleaning, where it returns to Stop or Pasto Cooling according to the Blackout Table.
A20 (BELT)	DELTA TGVTEV In Heating of Pasteurization, if TGV temperature becomes \geq TEV as to the value programmed in step DELTA TGVTEV, A20 is displayed and the machine sets back at STOP.



ALARM	DESCRIPTION
A22 (TIME OUT)	In Production: the beater motor is controlled and if staying ON more than 15' without reaching HOT, the machine sets at "Hot reached" status, with alarm A22. If, instead, the consistency value is below HOB (HOT Block) 15', the machine sets at Stop.
A24 (MIX OUT)	When the minimum level is on (level LED on) and in Production we dispense a number of portions same as or higher than the value set in step t23 (Last Cones), A24 is displayed and the machine sets at Storage mode. Top up in order to reset the alarm.
A30	If TEV is over 15°C in Stop, a Pasteurization cycle will be forced and the display shows A30.
Wnn - WAS	In production, everytime the beater motor starts, if we press the production key or we dispense an ice cream portion, Wnn is displayed, this means that there are still nn days to the machine wash. See WEEKLY CLEANING. The last days to cleaning, the display is WAS, which will be reset through the Selection key once the machine has been washed. Also when: the machine has been left 24 hours in Stop with mix level covered, Cleaning is forced (WASH) and the alarm resets soon after the machine wash (IMS).
Stb	In production, it may be displayed STB, meaning Stand By or ice cream not yet ready for distribution.
PHS	Phase controller. Machine is left in Stop. It is necessary to invert 2 phases in order to enable its functioning again. On turning the machine on, the alarm resets.
LOW	"LOW" blinks mix is out and reserve led is on. The alarm is active in all functions but Cleaning. An acoustic signal is activated in models PIZZA HUT and it plays till mix topping up.

4.1.1 Black-out

In case of a blackout, if the machine was:

- in Stop or Cleaning, on power return it sets at STOP.

- Production, Storage or Heating or Pause during Pasteurization: on power return, the machine sets back at the function where it was before blackout and alarm A15 will be displayed.

- Cooling step from Pasteurization,
on power return, the machine checks TEV temperature, as well as how long the blackout lasted; if time turns to be longer than the one shown in the table, the machine will executed the full pasteurization program again, whereas CHECK led is on and A15 is both on the display on and events list.

If, on the contrary, time is shorter than the one shown in the following table, the machine will set back at Cooling step from Pasteurization and A15 will be displayed.

Temperature TEV	Time
65°C - 50°C	30 minutes
49°C - 15°C	10 minutes
14°C - 10°C	20 minutes
9°C - 4°C	2 hours

5. CLEANOUT DISASSEMBLING AND REASSEMBLING OF PARTS IN CONTACT WITH THE PRODUCT

5.1 GENERAL DESCRIPTION

Cleaning and sanitisation are operations that must be carried out habitually and with maximum care at the end of each production run to guarantee the production quality and respect the necessary hygienic norms.

Giving dirt the time to dry out can greatly increase the risk of rings, marks and damage to surfaces.

Removing dirt is much easier if it is done immediately after use because there is the risk that some elements containing acid and saline substances can corrode the surfaces. A prolonged soaking is recommended.



5.2 WASHING CONDITIONS

- **Avoid using solvents, alcohol or detergents that could damage the component parts, the machine or pollute the functional production parts.**
- When manually washing never utilise powder or abrasive products, abrasive sponges or pointed utensils; there is a risk of dulling the surfaces, removing or deteriorating the protective film that is present on the surface and scoring the surface.
- Never ever use metal scouring pads or synthetic abrasives to stop any scouring action that could remove ferrous parts that could cause oxidisation or make the surfaces vulnerable.
- Avoid using detergents that contain chlorine and its composites. The use of these detergents such as bleach, ammoniac, hydrochloric acid and decalcifiers can attack the composition of the steel, marking it and oxidising it irreparably and causing damage to the “plastic” parts.
- Do not use dishwashers and their detergent products.



5.3 SUGGESTIONS

- Use a non-aggressive detergent solution to wash the parts.
- Manually wash the parts in water (max 60°C) using a non-aggressive detergent and the cleaning brushes supplied as standard.
- Use drinking water (bacteriologically pure) to rinse the parts.
- To sanitise leave the disassembled parts in sanitised tepid water for the time specified by the manufacturer of the product used (**use the sanitising product following the instructions of the manufacturer**) and rinse them before reassembling.
- When the washing procedure has been completed and before the reassembly of each component dry thoroughly with a clean and soft cloth that is suitable for coming into contact with foodstuffs, to avoid leaving any humidity rich in mineral salts and chlorine that could attack the metal surfaces and leave opaque traces.



Carpigiani recommends the use of sanitising detergent to wash the machine.

The use of detergent/sanitizer permits optimising the washing and sanitising process inasmuch that it eliminates two phases of the procedure (a rinse and a washing phase). Substantially, the use of detergent/sanitizer saves time facilitating and simplifying the washing/sanitising procedures.

ATTENTION

It is also essential that each time the machine is washed and parts in contact with the ice cream mix are removed, to make a visual check of all parts in thermosetting materials, plastics, elastomers, silicone and metal that come into contact with the product (for example, scrapers, pump gears, beaters, etc...).

Each part must be whole, not worn and without cracks or splits, or opaque, if originally polished/transparent.

Carpigiani refuses to accept any liability for damage caused through imperfection and/or failures not found and promptly solved, including with the use of original replacement parts, and is happy to provide help and consultation for all specific customer requests.



5.4 HOW TO USE DETERGENT/SANITIZER

Prepare a water-based solution and detergent/sanitizer following the instructions on the label product used.

Washing/sanitizing by soaking

- Remove larger residues by hand.
- Remove finer residues with a jet of water.
- Soak the parts to be cleaned in the detergent/sanitizer solution.
- Leave the solution to act for the time specified by the manufacturer of the product used.
- Rinse the parts with care, using plenty of clean drinking water.

5.5 DAILY CLEANING

Refer to the opening procedures (par. 3.9) and closing procedures (par. 3.10).

5.6 PROGRAMMED CLEANING TIME

The machine is equipped with an automatic system which calls for washing of the parts in contact with the product for example every 14 days.

This system, identified as "WASH", disables the dispensing function at the end of the fourteenth day after the latest cleaning. On the display, the message "USH" appears.

Every time the product is dispensed or the beater motor is activated, the display shows the number of days to the next cleaning date, as follows:

DAY	MESSAGE
3 days before	H-3
2 days before	H-2
1 day before	H-1
Disabling day	USH

WARNING

Cleanout and sanitization must be carried out at the programmed date indicated on the display (for example every 14 days), as a habit and with utmost care, in order to secure quality of production in the observance of healthy rules.

5.7 DRAINING AND CLEANING

1. Place an empty pail under the spout.
2. Press the **STOP** button.
3. Pull the dispensing lever and drain the ice cream.
4. Select CLENOUT function.
5. When the product coming out becomes liquid, push STOP button and leave the spout open.
6. Remove the hopper cover.
7. In the hopper, disconnect pressure pipe from the mix pump, turn it sideways, remove it pulling it up from its seat and let the product flow completely out. Grasp the pump and turn it in a clockwise direction of 45° then pull it out towards you.
8. Remove the hopper agitator by pulling it upwards.
9. Close the spout handle, pour 10 litres of cool and clean water into the mix hopper. Use the white hopper brush to scrub the mix hopper, mix level sensor and the outside the agitator shaft. Use the small brush to clean the mix inlet hole and the drive hub of the mix pump.
10. Place an empty pail under spout. Open the spigot piston and let the water drain out.
11. Rinse with warm water until the solution runs clear.
12. Select CLENOUT function and let the beater run for 10 seconds.
13. Turn the machine off by pushing the button and let the water flow out.

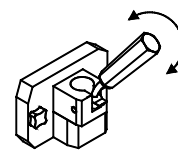

Fig. 19



5.8 DISASSEMBLING OF THE TANK MIXER

Remove the hopper agitator (pos. 162) by pulling it upwards.

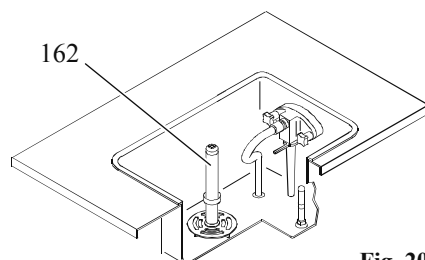

Fig. 20

5.9 DISASSEMBLING MIX PUMP

1. Keeping the feeding tube (pos. 271) upward turn it counterclockwise and pull it out.
2. Pull the spring (pos. 206) and the back flow valve (pos. 245) out. Using the o-ring extractor, remove the o-ring (1126).
3. Unscrew the 2 knobs (pos. 8) and separate the cover (pos. 202) from the pump body (pos. 39).
4. Tapping the pump body against the palm of your hand, remove the pump gears (pos. 38 and 38A). Using the o-ring extractor, remove the large o-ring (pos. 1178).
5. Remove the pump body seal (pos. 243).
6. Pull the connection tube (pos. 207) from the pressure pipe. Remove the o-rings (pos. 1117, 1126 and 1131).

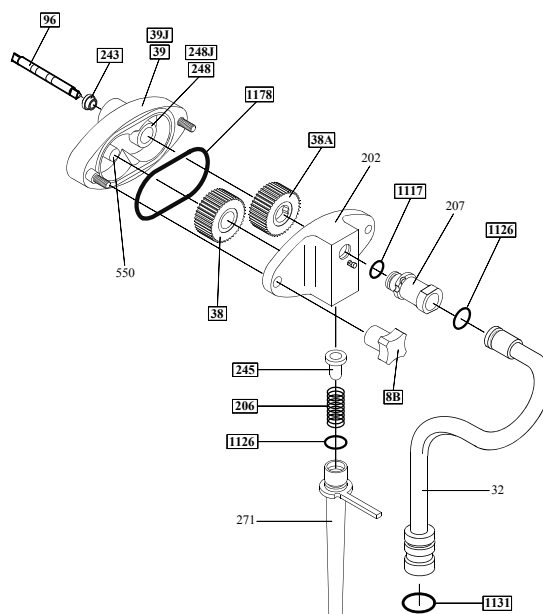

Fig. 21



5.10 DISASSEMBLING OF THE DISPENSING DOOR

CAUTION

Before disassembling the dispensing head, make sure that the hopper and the cylinder are completely drained.

1. Remove the two retaining knobs (pos. 8A) and pull the door assembly towards you sliding it off the two front panel studs.
2. Pull the dispensing handle (pos. 5) so the piston (pos. 30) raises in its housing.
3. Remove the pivot pin o-ring (pos. 1285) and the pivot pin (pos. 6) out releasing the dispensing handle (pos. 5).
4. Using the dispensing handle lever pull the piston (pos. 30) out completely.
5. Using the o-ring extractor, remove the two piston o-rings (pos. 1153), and the large dispensing door o-ring (pos. 1188).

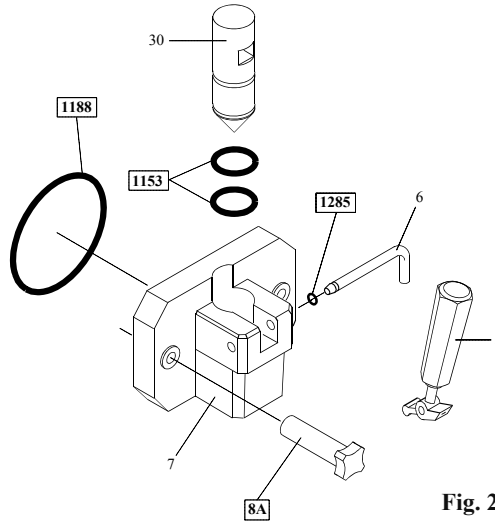

Fig. 23

5.11 DISASSEMBLING OF THE BEATER



Pull the beater (#21) out of the cylinder.

Slide the beater seal (#28) out of the beater shaft.

Pull out and remove the end pusher (#25P) and the idler (#24).

Remove the 3 beater blades (#430). Carpigiani suggests to replace the blades each 6 months.

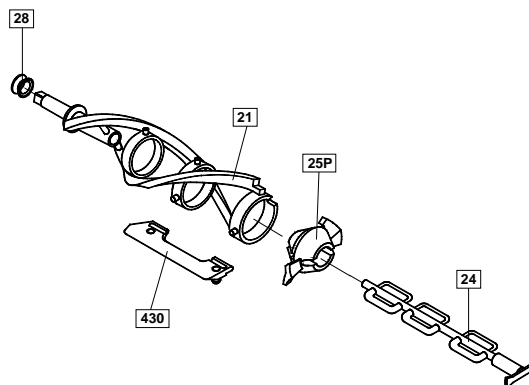

WARNING

The beater seal is very important. It must be checked regularly for wear and tear. It must always be on the beater shaft and properly lubricated, during operation, otherwise mix will leak in the drip tray.



5.12 WASHING AND SANITIZING OF COMPONENT PARTS

1. Manually remove the bulk of the residue.
 2. Remove the rest of the residue with a jet of water.
 3. Wash the parts in the detergent/sanitizer solution.
 4. Immerse the parts in the detergent/sanitizing solution for the time specified by the manufacturer of the product used (**use the detergent/sanitizing product following the instructions of the manufacturer**).
 5. Rinse with clean water.
 7. Place the components on a clean tray and let them dry naturally.
 8. Immerse a brush in the detergent/sanitizing solution and clean the cylinder.
 9. Immerse the brush in the detergent/sanitizing solution and clean the pump housing hole and the compression tube.
 10. Spray the sanitizing solution on the rear of the cylinder and on the walls of the tank.
- Repeat operations 8, 9 and 10 several times, then rinse with clean water.**

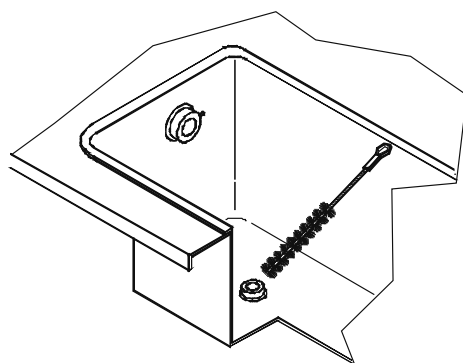

Fig. 26

5.13 REASSEMBLING OF THE HOPPER MIXER

Replace the hopper agitator (pos. 162) back in its seat: pay attention to engage it onto its shaft correctly.

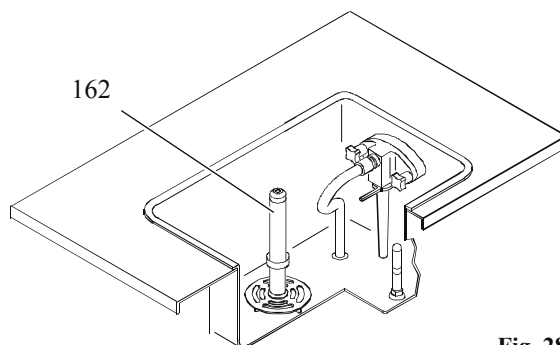

Fig. 28



5.14 REASSEMBLING MIX PUMP

1. Lubricate and replace the o-ring (pos. 1117) on the connection tube (pos. 207).
2. Lubricate and replace the o-rings (pos. 1126 and 1131) on the pressure pipe (pos. 32).
3. Insert the connection tube assembly in the pressure pipe (pos. 32).
4. Lubricate and replace the pump body o-ring (pos. 1178) and the pump body seal (pos. 243).
5. Lubricate the sides as well as the center of the pump gears (pos. 38 and 38A) with a thin film of lubricante insert them into the pump body (pos. 39). **Do not lubricate the teeth of the pump gears.**
6. Lubricate and replace the o-ring (pos. 1412) on the feeding tube (pos. 271).
7. Hold the pump cover (pos. 202) upside down and insert the back flow valve (pos. 245) and spring (pos. 206) in their pump cover housing.
8. Insert the feeding tube (pos. 271) in the pump cover: push and turn it clockwise.
9. Assemble the pump cover (pos. 202) with the feeding tube downwards onto the pump body and turn the two knobs (pos. 8) tightly; install the mix pump in the hopper with the blocking pin hook on the right, pushing and turning the pump in a clockwise direction and then in an anticlockwise direction until it locks onto the hopper blocking pin.

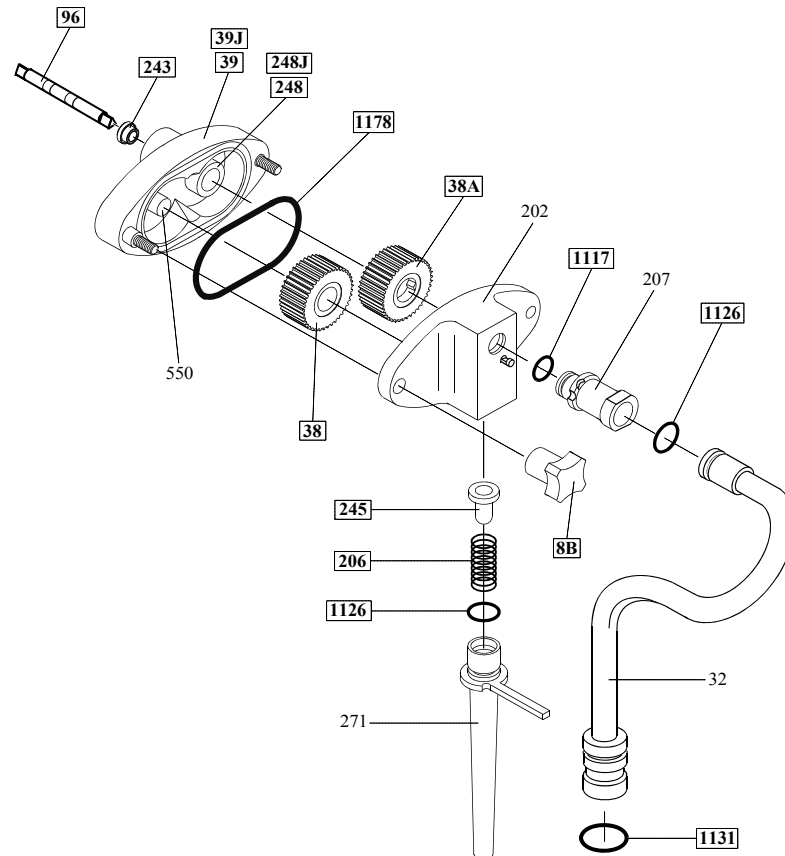

Fig. 29

5.15 REASSEMBLING OF THE BEATER

1. Insert the 3 beater blades (#430) onto the beater frame. Carpigiani suggests to replace the blades each 6 months.
2. Insert the end pusher (#25P) onto the beater frame.
3. Insert the end of the idler shaft (#24) in the rear housing of the beater, through the end pusher. Push the idler into position.
4. Lubricate the sides of the beater seal (#28) and slide it onto the beater shaft.

IMPORTANT

**Check the beater seal for integrity. Replace if worn or damaged.
It should be replaced rather frequently.**

5. Insert the beater assembly into the cylinder. Push it while turning it clockwise until it engages in its rear hub, otherwise the dispensing head cannot be fastened properly, mix can flow out and serious damage may occur.

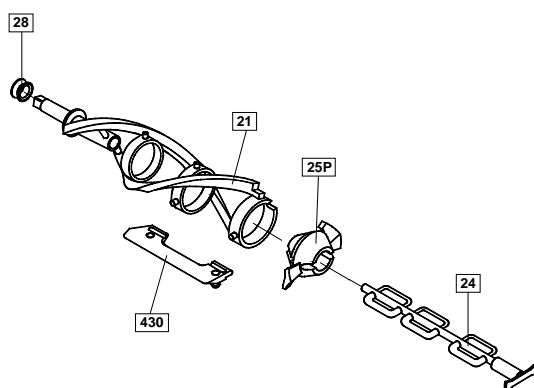

5.16 REASSEMBLING OF THE DISPENSING DOOR

1. Lubricate and slide the 2 piston o-ring (pos. 1153) into their seats.
2. Insert the piston (pos. 30), pointed end down, in the dispensing head (pos. 7) making sure that the piston square notch lines up with the rectangular opening on the spigot front.
3. Position the dispensing handle (pos. 5) on the door (pos. 7) and insert the pivot pin (pos. 6) in its housing through the handle lever hole. Lubricate and insert the pivot pin o-ring (pos. 1285). Lubricate and slide into its seat the large dispensing door o-ring (pos. 1188).
4. Insert the dispensing door assembly onto the two front panel studs and fasten it with the two knobs (pos. 8A) hand tight.

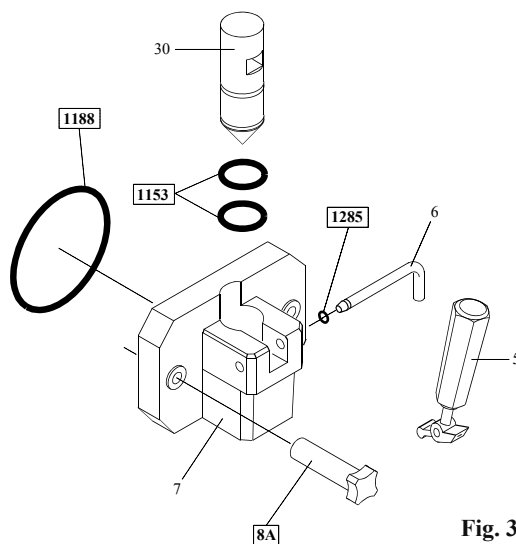

Fig. 32





5.17 SANITIZING THE WHOLE MACHINE

The machine must be sanitized before mix is poured in. Proceed as follows:

1. Fill the hopper to the maximum level with detergent/sanitizing solution prepared following the instructions on the label product used, and allow to drain into the cylinder.
2. Using the brush, clean the mix level probes, the entire surface of the mix hopper, the surface of the mix pump and the outside of the hopper agitator.
3. Select CLENOUT function and let the beater run for about 10 seconds. Press the STOP button. The cylinder and the pump are now filled with the detergent/sanitizing solution.
4. Return to the machine with a small amount of detergent/sanitizing solution in a pail.
5. Dip the door spout brush in the pail of detergent/sanitizing solution and brush clean the dispensing spout. Repeat the operation 2 times.
6. Wiper the exterior of machine with clean sanitized towel. Repeat the operation 2 times.
7. Wait for at least 5 minutes before proceeding with the next instructions.
8. Place an empty pail under the draw spout and pull the handle.
9. Allow all of the sanitizer to drain. If the sanitizing solution does not flow out completely, keep the spigot open and select CLENOUT function, keep the beater running for 5 seconds so that the last solution residues flow out then push STOP.

CAUTION

Do not keep the beater running for more than the time strictly needed to complete washing and sanitization. Without the lubrication of mix butterfat the beater wear out quickly.

10. Rinse by filling the cylinder with drinking water.
11. Drain the water from the cylinder by lowering the distribution lever.

5.18 MIX PRIMING

Prime Hopper:

- Take a bag of mixture from the refrigerator. Insert the mixture at a temperature of 4-5°C.
- Lower the distribution level and start to pour the mixture into the vat, permitting the mix to pass also into the cylinder. The level of the mixture in the vat must never reach the pump or the height of the feed needle; furthermore, it will be necessary to add mixture when the level has dropped to approximately 2 cms from the bottom.
- Wait until a small quantity of mixture discharges from the opening, bringing with it any sanitising residues and place the distribution level back in its original position, thereby closing the opening.

Connect the mix pressure pipe:

- Continue to pour in mixture and wait until the filling of the cylinder has finished (during the filling process, bubbles in the vat are visible). With clean and hygienic hands, take the feed needle from the sanitised solution and insert it into the bottom of the vat.
- The level of the mixture in the vat must never exceed the height of the feed needle (see figure); furthermore, it is also necessary to add mixture when the level has dropped to approximately 2 cms from the bottom.
- Reposition the vat cover.
- Select the production function.



6. MAINTENANCE

6.1 SERVICING TYPOLOGY

ATTENTION

Any servicing operation requiring the opening of machine panels must be carried out with machine set to stop and disconnected from main switch!

Cleaning and lubricating moving parts is forbidden!

“Repairs to the wiring, mechanical, air supply or cooling systems, or to parts of same must be carried out by qualified personnel with permission to do so and if necessary, according to the routine and extraordinary maintenance schedules as envisaged by the customer with reference to specific intervention methods, according to the use for which the machine is destined”.



Operations necessary to proper machine running are such that most of servicing is completed during production cycle.

Herebelow you can find a list of routine servicing operations:

- Cleanout and replacement of stuffing box

If the product drips from the side drip drawer, it means that the stuffing box (pos. 28) has no tightness.

When dismantling the beater, check the status of the stuffing box; based on how long the machine has been used, replace it if necessary, alternating it with the second stuffing box, provided with the accessories packet included in the packing.

If the stuffing box has no defects, it can still be used after washing it, i.e., when at room temperature, it has again its original shape.

To replace the stuffing box, proceed as follows.

Remove the beater unit.

Remove the stuffing box from its slot.

Lubricate the replacement stuffing box.

Mount the new stuffing box.

Clean and lubricate the replaced stuffing box and store it to allow it to regain flexibility.

WARNING

If you continue to work after noting traces of product in the drawer, you further accentuate the leakage of the stuffing box; this can lead to a malfunction of the machine serious enough to halt production.

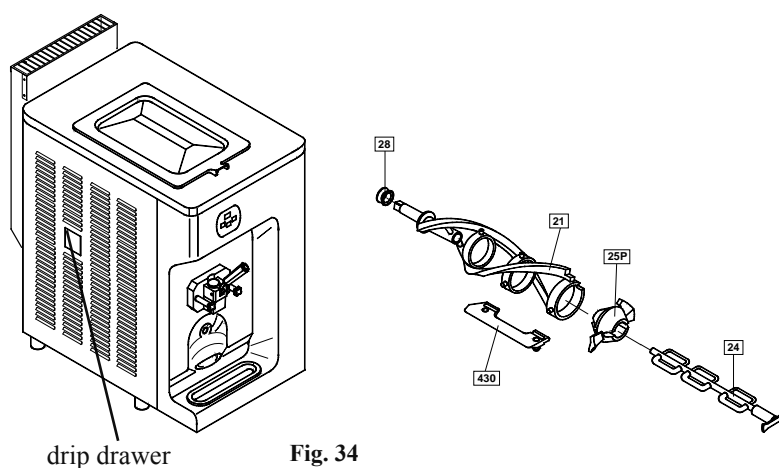

drip drawer

Fig. 34

**WARNING**

Like all moving parts, the complete beater is also subject to wear and tear. For this reason, we recommend checking the amount of wear to parts in direct contact with one another (beater/beater idler and beater/cylinder walls) on a regular basis during scheduled cleaning operations and in any case, every six months of machine operation. In particular, make sure that the wear on the bushing on the beater idler is no more than 2 mm, as indicated by the marking on the bushing itself. If there is more than 2 mm wear, it is necessary to replace the beater idler.

- **Cleanout of beater assembly, cleanout of pump or feeding needle, cleanout and sanitization of the all machine**
According to procedures described in section 5 of this manual.
- **Cleanout of panels**
To be carried out daily with neutral soap, seeing to it that cleansing solution never reaches beater assembly at its inside.

WARNING

Never use abrasive sponges to clean machine and its parts, as it might scratch their surfaces.

6.2 WATERCOOLING

By machines with watercooled condenser, water must be drained from condenser at the end of selling season in order to avoid troubles in the event that the machine is stored in rooms where temperature may fall under 0°C.

After closing water inlet pipe, withdraw drain pipe from its seat and let water flow out from circuit.

6.3 AIRCOOLING

Clean condenser, periodically, so as to remove dust, paper and what can prevent air from circulating. For cleanout, use a brush with long bristles or a bolt of compressed air.

**ATTENTION!**

When using compressed air, put on personal protections in order to avoid accidents; put on protective glasses!

NEVER USE SHARP METAL OBJECTS TO CARRY OUT THIS OPERATION. GOOD WORKING OF A FREEZING PLANT MOSTLY DEPENDS ON CLEANING OF CONDENSER.

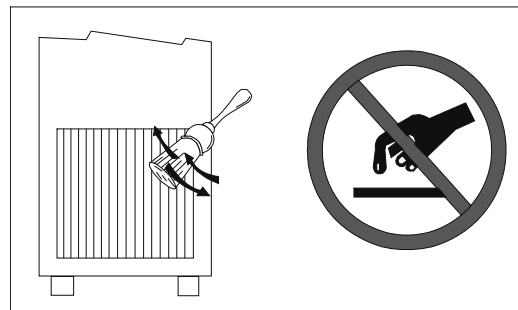

6.4 TABLE OF SPARE PARTS EQUIPMENT

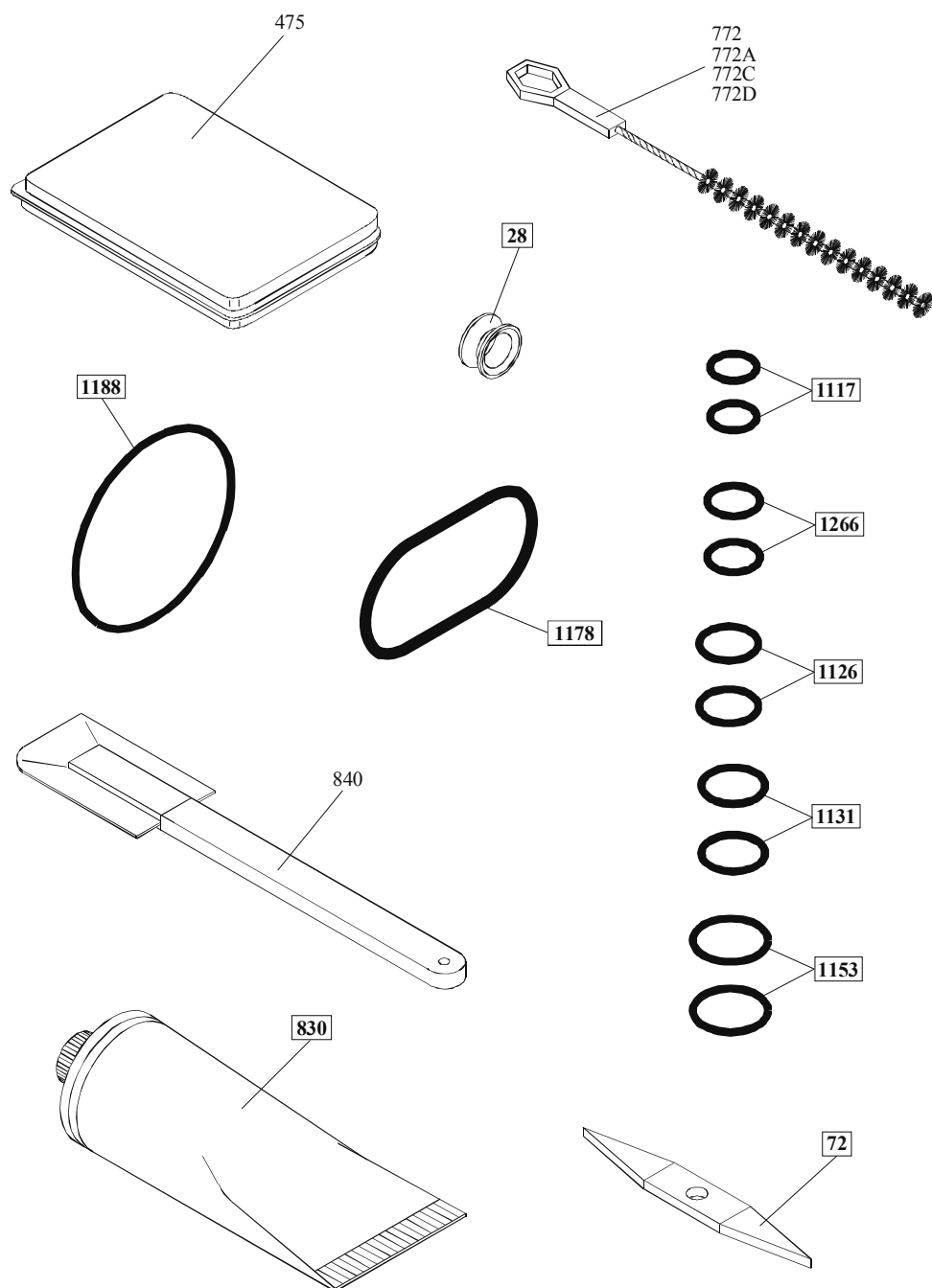

Fig. 37

Pos.	Description	Pos.	Description
28	Beater stuffing box	840	Cleaning spatula
72	O ring extractor	1117	Gasket OR
475	Accessories	1126	Gasket OR
772	Swab D 8x250	1131	Gasket OR
772A	Swab D 15x350	1153	Gasket OR
772C	Swab D 20x450	1178	Gasket OR
772D	Swab D 30x640	1188	Gasket OR
830	Food-grade lubricant tube	1266	Gasket OR

7 TROUBLESHOOT GUIDE

IRREGULARITY	CAUSE	PROCEDURE TO FOLLOW
Compressor starts and then stops after a few seconds.	1. If machine is watercooled: water is not circulating. 2. If machine is aircooled: air is not circulating.	1. Open water inlet cock and check that pipe is not squashed nor bent. 2. Check that machine clearance is at least 80 mm from wall. 2. Call for service if necessary
Mix or ice cream come out above or below piston though it is closed.	1. Piston without OR or OR is worn-out.	1. Stop the machine and insert or replace it with a new one if worn-out.
Mix coming out of drip drawer	1. Stuffing box missing or worn-out.	1. Stop the machine and install it if missing. If worn-out, replace it with a new one.
Piston hard to operate.	1. Dry sugar on piston.	1. Stop the machine and wash thoroughly and grease piston and OR with edible fat.
Ice cream comes out from front lid .	1. OR missing or not properly fit. 2. Front lid knobs not tightened evenly.	1. Stop the machine and check and put remedy. 2. Stop machine. loosen and tighten them again.
Low ice cream overrun	1. "R" pump not properly adjusted	1. Change regulator (Pos. 271).