

**PIE MERCHANDISER  
CARTER-HOFFMANN MODEL GPM1**

**MANUFACTURED BY  
CARTER-HOFFMANN  
1551 McCORMICK AVENUE  
MUNDELEIN, IL 60060  
PHONE: (847)362-5500  
FAX (847)367-8981  
TOLL FREE SERVICE:  
1 (800)323-9793**



**TABLE OF CONTENTS**

INTRODUCTION.....	1	NON-SCHEDULED MAINTENANCE.....	2
SAFETY.....	1	WIRING DIAGRAMS & REPLACEMENT PARTS.....	3
INSTALLATION.....	2	SERVICE & REPAIRS .....	4
OPERATION.....	2	WARRANTY.....	4
CLEANING INSTRUCTIONS.....	2		

**INTRODUCTION**

The GPM1 Pie Merchandiser is designed to hold pies at serving temperature. The cabinet has a programmable controller with a low temperature alarm. The controller is factory pre-set for a holding temperature of 165°F (74°C) for individually boxed pies. The heater can be accessed for service by removing the top cover. There is also a bottom panel to access the wiring and the switch. Each cabinet includes a removable pie caddy.

**SAFETY**

Knowledge of proper installation, operation and maintenance procedures is essential to ensure safe operation of any equipment.

1. Always have dry hands prior to turning the ON/OFF switch ON or OFF.
2. Turn OFF the ON/OFF switch any time the cabinet is not in use.
3. If an electrical shock is felt when touching the cabinet, disconnect the power immediately and call Carter-Hoffmann's Technical Service Department for assistance and service.
4. If you find the power cord is frayed or the plug damaged, DO NOT PLUG IT INTO THE ELECTRICAL RECEPTACLE. IF IT IS ALREADY PLUGGED IN, SHUT OFF THE MAIN CIRCUIT BREAKER, LOCATED IN THE BREAKER BOX AT THE REAR OF THE STORE. THEN DISCONNECT THE PLUG.
5. DISCONNECT THE POWER CORD BEFORE ATTEMPTING ANY REPAIRS TO THE CABINET AND/OR CLEANING THE UNIT.
6. DO NOT SUBMERGE THE CABINET. ELECTRICAL COMPONENTS AND WIRING PRESENT A HIGH SHOCK HAZARD WHEN WET.



220v/240v only

## INSTALLATION

1. Remove the cabinet from shipping carton making sure all packing materials are removed from the carton and cabinet.
2. Check to ensure all components are included: Cabinet, Pie Caddy, Equipment Manual
3. Read this equipment manual completely before operating the cabinet.
4. Locate cabinet on clean, dry surface.
5. Clean cabinet thoroughly before use.
6. Connect the cabinet power cord to a correctly-wired and protected power source.

## OPERATION

1. The power switch is located at the base of the cabinet, underneath the door. Turn the power switch on. Preheat cabinet for 30 minutes. When the cabinet is turned on, the air heater will operate until the cabinet reaches the air temperature setpoint.
2. After preheat, load cooked/baked, boxed pies into cabinet.
3. Cabinet dispenses pies from the bottom, underneath the door.
4. When cabinet is not in use, turn power off.
5. This cabinet must be cleaned **DAILY**.

**NOTE:** The pie caddy has a reserve storage of 12 pies. This reserve is intended to provide additional pies while a new batch of pies are being baked. Holes beneath the door provide visual indication of low pie level in the cabinet.

## CLEANING INSTRUCTIONS

**WARNING:** Be sure cabinet is cool and unplugged before cleaning. The heater components should not be exposed to direct contact with water or cleaning sprays. **DO NOT SPRAY WITH WATER DURING CLEANING.** Permanent damage to the electrical components will result.

1. Remove all food products and containers from the cabinet. Turn the power switch to OFF. Unplug cabinet and allow it to cool.
2. Remove the pie caddy and bring to back sink. Wash in sink, rinse and sanitize. Use a NO-SCRATCH pad on heavy soils.
3. Clean the interior and exterior of cabinet with a clean, sanitized towel. Use a NO-SCRATCH pad on heavy soils.
4. After the cabinet and pie caddy have been thoroughly air-dried, place the pie caddy back in the cabinet.
5. Reconnect power cord.

**CAUTION:** Cleansers, detergents, degreasers, sanitizers or bleaching agents that contain chlorides or phosphates will cause permanent damage to stainless steel products. The damage appears as pits, eruptions, voids, small holes, cracks, severe discoloration, or dulling of the metal finish. Water with high chloride content can also damage stainless steel. If you are uncertain of your water quality, we recommend you have it tested. **THIS DAMAGE IS PERMANENT, COSTLY TO REPAIR, AND IS NOT COVERED BY THE WARRANTY.**

## NON-SCHEDULED MAINTENANCE

### Changing Illuminated Front Graphic on Door:

Tools: Phillips Screwdriver

Remove the four screws on the sides of the door and remove the door trim. Slide the POP graphic out. Slide new POP graphic in, making sure to leave white diffuser background panel in place. Replace the door trim and secure with screws.

### Changing the Light Bulb in the Door:

Tools: Phillips Screwdriver

The POP graphic on the front door is illuminated by one fluorescent bulb. If a bulb burns out, turn off the cabinet. Remove the four screws on the sides of the door and remove the door trim. Replace the burned out bulb, replace door trim, and secure with screws. Turn the power switch on.

**NOTE:** Lamp contains mercury. Manage in accordance with disposal laws.

# WIRING DIAGRAMS & REPLACEMENT PARTS

## REPLACEMENT PARTS - 220-240V 500W 2.5A 50-60HZ 1PH

Part Number	Description
1	18612-0222 *Heat Element, 220 Volt, 500 Watt
2	18614-0340 *Fan Motor 220 Volt, 50-60 Hz
3	18614-0323 *Cooling Fan 220 Volt
4	18616-0229 *Controller
5	18616-0252 *Light Socket
6	18616-0208 *Light Bulb
7	18602-0075 *On/Off Switch 220 Volt
8	18603-5090 Fan Blade
9	18605-0200 *10' Power Cord
10	16090-2213 Pie Caddy
11	18616-0131 *Transformer 220 Volt
12	18616-0223 *Relay 24 Volt
13	18616-0144 *Ballast 220 Volt
14	18617-0002 Cord Grip
15	18616-0198 *Probe

Part Number	Description
16	29037-9003 White Diffuser Panel
17	18305-0071 Rubber Foot
18	18600-0062 *Snap Disc 155° (68°C)
19	18600-0049 *Snap Disc 243° (115°C)
20	18312-0194 Name Plate
21	16502-8541 Door Trim
22	18312-0189 Overlay, Controller
**	29037-9013 POP Graphic
**	16090-2462 Top Hinge Assembly
**	16090-2508 Bottom Hinge Assembly
**	16090-2235 Magnetic Shield Assembly

\*WEEE Parts & Locations

\*\*Not Shown

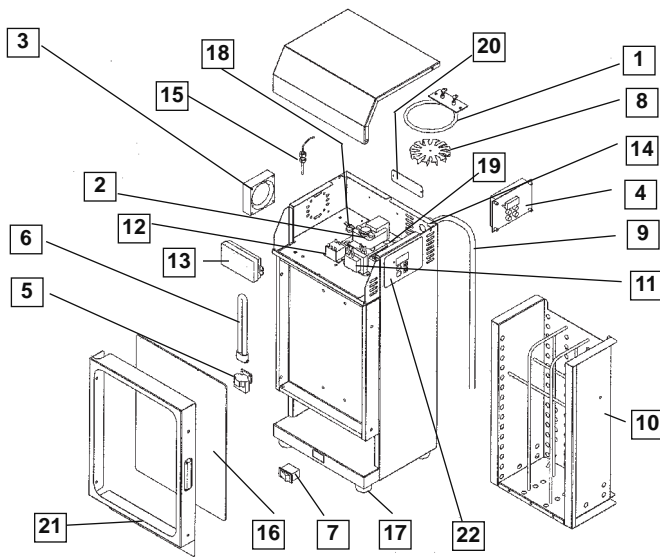

## WIRING DIAGRAM - 220-240V 500W 2.5A 50-60HZ 1PH

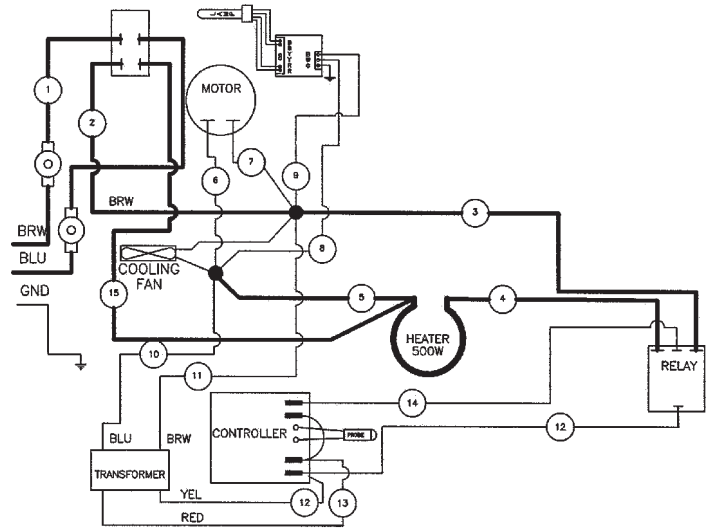

## 120V 500W 4.6A 60HZ 1PH

Part Number	Description
18612-0221	Heat Element 120 Volt, 500 Watt
18614-0330	Fan Motor 120 Volt, 60 Hz
18614-0322	Cooling Fan 120 Volt
18616-0135	Transformer 120 Volt
18616-0136	Relay 24 Volt
18616-0207	Controller
18616-0197	Ballast
18616-0147	Light Socket
18616-0146	Light Bulb
18602-0055	On/Off Switch 120 Volt
18603-5090	Fan Blade
18617-0002	Cord Grip
18605-0016	Power Cord w/ Plug
18600-0062	Snap Disc 155° (68°C)
18600-0049	Snap Disc 243° (115°C)
18616-0198	Probe

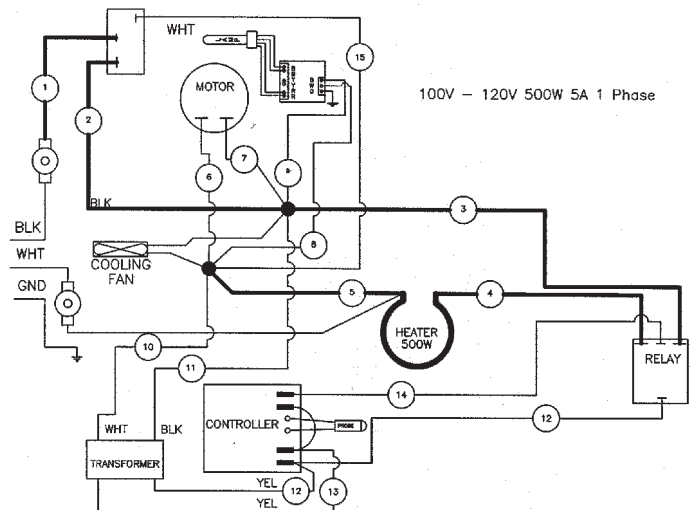

**For service call Carter-Hoffmann at 800-323-9793 to schedule repairs by a qualified service technician.**

### **WARRANTY STATEMENT**

Carter-Hoffmann ("CARTER-HOFFMANN") warrants to the initial purchaser of its standard Carter Line Products that CARTER-HOFFMANN will, at its option, repair or replace, during the warranty period set forth below, any part of such products made necessary due to a defect in material or workmanship which is present when the product leaves its factory and which manifests itself during the warranty period under normal use and service.

This warranty applies only to original equipment owned and possessed by the initial purchaser and the warranty period begins on the date of original shipment from the CARTER-HOFFMANN factory and extends as follows: **to component parts and labor for 12 months; to refrigeration compressor unit for one year** (limited to replacement only - not to include labor for removal, repair or replacement).

Repair or replacements under this warranty will be performed, unless otherwise authorized in writing by CARTER-HOFFMANN, at its factory. All parts or components to be repaired or replaced under this warranty are to be shipped prepaid to CARTER-HOFFMANN, with reimbursement credit for such part or component to be given if found by CARTER-HOFFMANN to be defective.

CARTER-HOFFMANN neither makes nor assumes and does not authorize any other person to make or assume any obligation or liability in connection with its products other than that covered in this warranty. This warranty applies only within the continental United States and Canada. In Alaska and Hawaii, this warranty applies only to and is limited to the supply of replacement parts.

Any implied warranty of merchantability or fitness for a particular purpose is hereby specifically disclaimed by CARTER-HOFFMANN. There are no warranties, expressed or implied, which extend beyond the description on the face hereof.

This warranty does not cover and CARTER-HOFFMANN shall not under any circumstances be liable for any incidental, consequential or other damages (such as injury to persons or property, loss of time, inconvenience, loss of business or profits, or other matters not specifically covered) arising in connection with the use of, inability to use, or failure of these products.