

HL1, HL2, HL3, HL4 & HLM1 Series ALUMINUM HEATED HOLDING CABINETS & HEATER PROOFERS

OWNERS / OPERATORS MANUAL



MANUFACTURED BY:

CARTER-HOFFMANN
 1551 McCormick Avenue
 Mundelein, IL 60060 U.S.A.

Phone: 847-362-5500
 Fax: 847-367-8981
 Toll Free: 800-323-9793
 Email: technicalservice@carter-hoffmann.com



HL2-18

<p>HL1 HEATED CABINETS (non-insulated)</p> <p>Models: HL1-5, HL1-8, HL1-14 & HL1-18</p> <p>Formerly models: HBU5A2GM HBU8A2GM HBU14A2GM HBU18A2GM HBC10A2GM HBC16A2GM HBC28A2GM HBC36A2GM HBF5A2GM HBF8A2GM HBF14A2GM HBF18A2GM</p>	<p>HL2 HEATER/PROOFERS (non-insulated)</p> <p>Models: HL2-5, HL2-8, HL2-14 & HL2-18</p> <p>Formerly models: HWU5A2GM HWU8A2GM HWU14A2GM HWU18A2GM HWC10A2GM HWC16A2GM HWC28A2GM HWC36A2GM HWF5A2GM HWF8A2GM HWF14A2GM HWF18A2GM</p>	<p>HL3 HEATED CABINETS (insulated)</p> <p>Models: HL3-5, HL3-8, HL3-14, HL3-18</p> <p>Formerly models: HBU5A1GM HBU8A1GM HBU14A1GM HBU18A1GM HBC10A1GM HBC16A1GM HBC28A1GM HBC36A1GM HBF5A1GM HBF8A1GM HBF14A1GM HBF18A1GM</p>	<p>HL4 HEATER/PROOFERS (insulated)</p> <p>Models: HL4-5, HL4-8, HL4-14, HL4-18</p> <p>Formerly models: HWU5A1GM HWU8A1GM HWU14A1GM HWU18A1GM HWC10A1GM HWC16A1GM HWC28A1GM HWC36A1GM HWF5A1GM HWF8A1GM HWF14A1GM HWF18A1GM</p>
<p>HLM1 HEATED CABINETS (non-insulated) Models: HLM1-14 , HLM1-18</p>			

TABLE OF CONTENTS

SAFETY PRECAUTIONS.....	2
FEATURES & SPECIFICATIONS.....	3-7
UNPACKING, INSPECTION & FREIGHT DAMAGE.....	8
INSTALLATION & STARTUP	9
DETAILS: CONTROLS AND WATER PANS.....	10
NORMAL OPERATION: HL1, HL3 & HLM1 HEATED CABINETS.....	11
NORMAL OPERATION: HL2 & HL4 HEATER PROOFERS	12
FOOD HOLDING GUIDE.....	13
DAILY CLEANING PROCEDURES.....	14
CABINET MAINTENANCE.....	15
WIRING DIAGRAMS.....	16
REPLACEMENT PARTS.....	17
TROUBLESHOOTING GUIDE	18
WARRANTY STATEMENT.....	19

SAFETY PRECAUTIONS



WARNING: ELECTRIC SHOCK HAZARD

All service requiring access to non-insulated components must be performed by qualified service personnel. Failure to heed this warning may result in severe electric shock.



CAUTION: ELECTRIC SHOCK HAZARD

Disconnect this appliance from electrical power before performing any maintenance or service.



CAUTION: BURN HAZARD

Exposed metal surfaces can be hot to the touch and may cause burns.

IMPORTANT SAFETY INSTRUCTIONS

When using electrical appliances basic safety precautions should be followed, including the following:

- 1) Be familiar with the appliance use, limitations and associated restrictions. Operating instructions must be read and understood by all persons using or installing this appliance.
- 2) This appliance must be grounded. Connect only to properly grounded outlet.
- 3) Use this appliance only for its intended purpose as described in the manual.
 - a. This equipment is specifically designed to hold pre-cooked food at temperature.
 - b. This equipment is intended for use in commercial establishments only.
 - c. This equipment is not designed for industrial or laboratory use.
- 4) Cleanliness of this appliance and its accessories is essential to good sanitation.
- 5) DO NOT submerge this appliance in water. This appliance is not jet stream approved. DO NOT direct water jet or steam jet at this appliance, or at any control panel or wiring. DO NOT splash or pour water on, in or over any controls, control panel or wiring. DO NOT use corrosive chemicals or vapors in this appliance.
- 6) DO NOT store this appliance outdoors. DO NOT use this product near water – for example, near a kitchen sink, in a wet basement, or near a swimming pool, and the like.
- 7) DO NOT operate this appliance if it has a damaged cord or plug, if it is not working properly, or if it has been damaged or dropped. Do not immerse cord or plug in water, keep cord away from heated surfaces, and do not let cord hang over edge of table or counter.
- 8) DO NOT cover or block any openings on the appliance.
- 9) **Only qualified service personnel should service this appliance.**

NOTE: The technical content of this manual, including any wiring diagrams, schematics, parts breakdown illustrations and/or adjustment procedures, is **intended for use by qualified technical personnel** and is subject to change without notice.

HL1 NON-INSULATED ALUMINUM HEATED CABINET FEATURES & SPECIFICATIONS



HL1 Features & Benefits

- Precision-engineered bottom mount heater with superior heat-up and recovery time
- Analog heat control. Digital thermometer. Temperature range of 90°- 190°F
- Four sizes, available with adjustable universal, fixed universal or adjustable universal slides
- All swivel heavy-duty casters, front casters fitted with brakes
- Field reversible glass door in heavy-duty extruded aluminum frame is standard, black anodized solid aluminum door is optional
- Fixed wire universal slides for 18"x26" sheet pans and 12"x20"x2.5" steam table pans

Cabinets with Adjustable Universal, Fixed Universal or Angle Slides

Model Number	Pan/Tray Capacity*		Slide Pairs Provided	Overall Dimensions			Caster Diameter in (mm)	Class 100 Shipping Weight lbs (kgs)
	12"x20"	18"x26"		Height	Depth in (mm)	Width		
HL1-5 (under-counter)	10	5	5	31-1/16 (789)	29-1/2 (749)	24-11/16 (627)	5 (127)	99 (45)
HL1-8 (1/2 size)	16	8	8	40-1/16 (1018)	29-1/2 (749)	24-11/16 (627)	5 (127)	137 (62)
HL1-14 (3/4 size)	28	14	14	58-1/16 (1474)	29-1/2 (749)	24-11/16 (627)	5 (127)	155 (70)
HL1-18 (full size)	36	18	18	70-1/16 (1780)	29-1/2 (749)	24-11/16 (627)	5 (127)	198 (90)

* fixed spacing at 3"

APPROVALS:



Conforms to UL Std 197
certified to CAN/CSA Std
C22.2 No. 109

3174974



Conforms to
NSF/ANSI
Std 4

3174974

Electrical Information NEMA Plug Type	
1800 watts 120 volts 15.0 Amps 60 Hz Single Phase	NEMA 5-20P 



International voltage:
220 volts, 1800 watts,
8.2 Amps, 50 Hz, single
phase, plug cap per
specific country require-
ments / standards



Canadian Voltage:
120v, 1400 watts,
12Amps, NEMA 5-15P

HLM1 NON-INSULATED ALUMINUM MERCHANDISING CABINETS



HL1 Features & Benefits

- Precision-engineered bottom mount heater with superior heat-up and recovery time
- Analog heat control. Digital thermometer. Temperature range of 90°-190°F
- 3/4 and full sized cabinets with adjustable racks and shelves to accommodate a variety of items, including pizza boxes
- All swivel heavy-duty casters, front casters fitted with brakes
- Field reversible glass door in heavy-duty extruded aluminum frame is standard, black anodized solid aluminum door is optional
- Tempered glass doors and walls; pass-through design



Cabinets with Adjustable Racks and Shelves

Model Number	Capacity*		Shelves	Overall Dimensions			Caster Diameter in (mm)	Class 100 Shipping Weight lbs (Kgs)
	12"x20" Pizza Boxes	18"x26" Sheet Pans		Height	Depth in (mm)	Width		
HLM1-14 (3/4 size)	28	14*	3	58-5/8 (1489)	30-1/4 (781)	24-5/8 (625)	5 (127)	155 (70)
HLM1-18 (full size)	36	18*	4	70-5/8 (1780)	30-1/4 (781)	24-5/8 (625)	5 (127)	198 (90)

* on optional wire racks with fixed spacing at 3"

APPROVALS:



Conforms to UL Std 197 certified to CAN/CSA Std C22.2 No. 109

3174974



Conforms to NSF/ANSI Std 4

3174974

Electrical Information NEMA Plug Type	
1800 watts 120 volts 15.0 Amps 60 Hz Single Phase	NEMA 5-20P 



International voltage:
220 volts, 1800 watts,
8.2 Amps, 50 Hz, single
phase, plug cap per
specific country require-
ments / standards



Canadian Voltage:
120v, 1400 watts,
12Amps, NEMA 5-15P

HL2 NON-INSULATED ALUMINUM HEATER/PROOFER FEATURES & SPECIFICATIONS



HL2 Features & Benefits

- Precision-engineered bottom mount heater with superior heat-up and recovery time
- Analog heat and humidity levels. Digital thermometer. Temperature range of 90°- 190°F
- Can be operated with or without humidity. Capable of humidified holding as well as proofing
- Four sizes, available with adjustable universal, fixed universal or adjustable universal slides
- All swivel heavy-duty casters, front casters fitted with brakes
- Field reversible glass door in heavy-duty extruded aluminum frame is standard, black anodized solid aluminum door is optional
- Fixed wire universal slides for 18"x26" sheet pans and 12"x20"x2.5" steam table pans

Cabinets with Adjustable Universal, Fixed Universal or Angle Slides

Model Number	Pan/Tray Capacity*		Slide Pairs Provided	Overall Dimensions			Caster Diameter in (mm)	Class 100 Shipping Weight lbs (kgs)
	12"x20"	18"x26"		Height	Depth in (mm)	Width		
HL2-5 (under-counter)	10	5	5	31-1/16 (789)	29-1/2 (749)	24-11/16 (627)	5 (127)	99 (45)
HL2-8 (1/2 size)	16	8	8	40-1/16 (1018)	29-1/2 (749)	24-11/16 (627)	5 (127)	137 (62)
HL2-14 (3/4 size)	28	14	14	58-1/16 (1474)	29-1/2 (749)	24-11/16 (627)	5 (127)	155 (70)
HL2-18 (full size)	36	18	18	70-1/16 (1780)	29-1/2 (749)	24-11/16 (627)	5 (127)	198 (90)

* fixed spacing at 3"

APPROVALS:



Conforms to UL Std 197
certified to CAN/CSA Std
C22.2 No. 109



Conforms to
NSF/ANSI
Std 4

Electrical Information NEMA Plug Type

2100 watts
120 volts
17.5 Amps
60 Hz
Single Phase



International voltage:
220 volts, 2100 watts,
9.5 Amps, 50 Hz, single
phase, plug cap per
specific country require-
ments / standards



Canadian Voltage:
120v, 1400 watts,
12Amps, NEMA 5-15P

HL3 INSULATED ALUMINUM HEATED CABINET FEATURES & SPECIFICATIONS



HL3 Features & Benefits

- Precision-engineered bottom mount heater with superior heat-up and recovery time
- Analog heat control. Digital thermometer. Temperature range of 90° - 190°F
- Four sizes, available with adjustable universal, fixed universal or adjustable universal slides
- All swivel heavy-duty casters, front casters fitted with brakes
- Field reversible glass door in heavy-duty extruded aluminum frame is standard, black anodized solid aluminum door is optional
- Fixed wire universal slides for 18"x26" sheet pans and 12"x20"x2.5" steam table pans

Cabinets with Adjustable Universal, Fixed Universal or Angle Slides

Model Number	Pan/Tray Capacity*		Slide Pairs Provided	Overall Dimensions			Caster Diameter in (mm)	Class 100 Shipping Weight lbs (kgs)
	12"x20"	18"x26"		Height	Depth in (mm)	Width		
HL3-5 (under-counter)	10	5	5	31-5/8 (803)	31-1/2 (800)	26-1/2 (673)	5 (127)	104 (47)
HL3-8 (1/2 size)	16	8	8	40-5/8 (1032)	31-1/2 (800)	26-1/2 (673)	5 (127)	147 (67)
HL3-14 (3/4 size)	28	14	14	58-5/8 (1489)	31-1/2 (800)	26-1/2 (673)	5 (127)	170 (77)
HL3-18 (full size)	36	18	18	70-5/8 (1794)	31-1/2 (800)	26-1/2 (673)	5 (127)	218 (99)

* fixed spacing at 3"

APPROVALS:



Conforms to UL Std 197
certified to CAN/CSA Std
C22.2 No. 109

3174974



Conforms to
NSF/ANSI
Std 4

3174974

Electrical Information NEMA Plug Type	
1800 watts 120 volts 15.0 Amps 60 Hz Single Phase	NEMA 5-20P 



International voltage:
220 volts, 1800 watts,
8.2 Amps, 50 Hz, single
phase, plug cap per
specific country require-
ments / standards



Canadian Voltage:
120v, 1400 watts,
12Amps, NEMA 5-15P

HL4 INSULATED ALUMINUM HEATER/PROOFER FEATURES & SPECIFICATIONS



HL4 Features & Benefits

- Precision-engineered bottom mount heater with superior heat-up and recovery time
- Analog heat and humidity levels. Digital thermometer. Temperature range of 90°- 190°F
- Can be operated with or without humidity. Capable of humidified holding as well as proofing
- Four sizes, available with adjustable universal, fixed universal or adjustable universal slides
- All swivel heavy-duty casters, front casters fitted with brakes
- Field reversible glass door in heavy-duty extruded aluminum frame is standard doors are standard, solid aluminum door is optional
- Fixed wire universal slides for 18"x26" sheet pans and 12"x20"x2.5" steam table pans

Cabinets with Adjustable Universal, Fixed Universal or Angle Slides

Model Number	Pan/Tray Capacity*		Slide Pairs Provided	Overall Dimensions			Caster Diameter in (mm)	Class 100 Shipping Weight lbs (Kgs)
	12"x20"	18"x26"		Height	Depth	Width		
HL4-5 (under-counter)	10	5	5	31-5/8 (803)	31-1/2 (800)	26-1/2 (673)	5 (127)	104 (47)
HL4-8 (1/2 size)	16	8	8	40-5/8 (1032)	31-1/2 (800)	26-1/2 (673)	5 (127)	147 (67)
HL4-14 (3/4 size)	28	14	14	58-5/8 (1489)	31-1/2 (800)	26-1/2 (673)	5 (127)	170 (77)
HL4-18 (full size)	36	18	18	70-5/8 (1794)	31-1/2 (800)	26-1/2 (673)	5 (127)	218 (99)

* fixed spacing at 3"

APPROVALS:



Conforms to UL Std 197
certified to CAN/CSA Std
C22.2 No. 109

3174974



Conforms to
NSF/ANSI
Std 4

3174974

Electrical Information NEMA Plug Type

2100 watts
120 volts
17.5 Amps
60 Hz
Single Phase



International voltage:
220 volts, 2100 watts,
9.5 Amps, 50 Hz, single
phase, plug cap per
specific country require-
ments / standards



Canadian Voltage:
120v, 1400 watts,
12Amps, NEMA 5-15P



This appliance should be thoroughly cleaned prior to use.

See the **CLEANING INSTRUCTIONS** in this manual.

NOTE: DO NOT discard the carton or other packing materials until you have inspected the appliance for hidden damage and checked it for proper operation.

Refer to **SHIPPING DAMAGE CLAIM PROCEDURE** on bottom of this page.

UNPACKING AND INSPECTION

1. Remove the cabinet from shipping carton, ensuring that all packing materials and protective plastic has been removed from the unit.
2. Inspect all components for completeness and condition.
3. If any freight damage is present, a freight claim must be filed immediately with the shipping company.
4. **Freight damage is not covered under warranty.**
5. Check to insure all components are included: cabinet, instruction packet and additional accessories.
6. Read operation instructions completely.
7. Appliance should be thoroughly cleaned before use. See **CLEANING INSTRUCTIONS** in this manual.

FREIGHT DAMAGE PROCEDURE

NOTE: For your protection, please note that equipment in this shipment was carefully inspected and packaged by skilled personnel before leaving the factory. Upon acceptance of this shipment, the transportation company assumes full responsibility for its safe delivery.

IF SHIPMENT ARRIVES DAMAGED:

1. **VISIBLE LOSS OR DAMAGE:** Be certain that any visible loss or damage is noted on the freight bill or express receipt, and that the note of loss or damage is signed by the delivery person.
2. **FILE CLAIM FOR DAMAGE IMMEDIATELY:** Regardless of the extent of damage. **Contact your dealer immediately.**
3. **CONCEALED DAMAGE:** If damage is unnoticed until the merchandise is unpacked, notify the transportation company or carrier immediately, and then file a "CONCEALED DAMAGE" claim with them. This should be done within fifteen (15) days from the date the delivery was made to you. **Be sure to retain the container for inspection.**

Carter-Hoffmann cannot assume liability for damage or loss incurred in transit, **freight damage is not covered under warranty.** We will, however, at your request, supply you with the necessary documents to support your claim.

INSTALLATION AND STARTUP



WARNING: Risk of personal injury

Installation procedures must be performed by a qualified technician with full knowledge of all applicable electrical codes. Failure could result in personal injury and property damage.



IMPORTANT: Power cord is 8' long

If necessary, contact a licensed electrician to install an appropriate 20 amp electrical circuit with correct NEMA receptacle.

DO NOT use an extension cord.



CAUTION: Electrical Shock Hazard

The ground prong of the power cord is part of a system designed to protect you from electric shock in the event of internal damage.

DO NOT cut off the large round ground prong or twist a blade to fit an existing receptacle.



IMPORTANT: Not under warranty

Damage to unit due to being connected to the wrong voltage or phase is **NOT** covered by warranty.



WARNING: Risk of personal injury

Unit is not waterproof, to avoid electrical shock, keep unit from being submerged in water. Do not operate if unit has been in contact with water.

LOCATION

For proper operation and maximum performance, locate the unit in an ambient air temperature of 70°F (21°C).

Avoid placement in areas near exhaust fans or where there are active air movements.

For safe operation and maximum performance, locate the unit at least 2" from any wall or combustible material.

Unit must be on a solid level surface.

GROUNDING INSTRUCTIONS

This appliance is equipped with a cord having a grounding wire with a grounding plug which must be plugged into an outlet that is properly installed and grounded. In the event of an electrical short circuit, grounding reduces the risk of electric shock by providing an escape wire for the electric current.

WARNING—Improper use of the grounding can result in a risk of electric shock. Consult a qualified electrician or service agent if the grounding instructions are not completely understood, or if doubt exists as to whether the appliance is properly grounded.

START UP

1. Prior to use, thoroughly clean the interior of the unit, per the instructions in this manual. Familiarize yourself with the controls.
2. Plug the power cord of the cabinet into a grounded outlet with a electrical service according to the electrical information provided below. **DO NOT MODIFY CORD PLUG.**
3. Set POWER switch to the "ON" position.
4. Do not load product into the cabinet. Allow the heat to remove any residual oils which may adhere to inside metal surfaces. A slight emission of smoke is common during the first few hours of operation.

Electrical Information NEMA Plug Type	
1800 watts 120 volts 15.0 Amps 60 Hz Single Phase	NEMA 5-20P 

HL1 & HL3 Models

Electrical Information NEMA Plug Type	
2100 watts 120 volts 17.5 Amps 60 Hz Single Phase	NEMA 5-20P 

HL2 & HL4 Models

220 volt CE international versions:

HL1 & HL3 Series: 1800 watts, 220 volts, 8.2 Amps, 50/60 Hz, single phase

HL2 & HL4 Series: 2100 watts, 220 volts, 9.5 Amps, 50/60 Hz, single phase

Plug cap per specific country requirements / standards

Canada: 1400 watts, 120 volts, 12 Amps, single phase, NEMA 5-15P

DETAILS: CONTROL PANELS & WATER PANS

HL1 & HL3 Series Heated Holding Cabinets & HLM1 Series Merchandisers

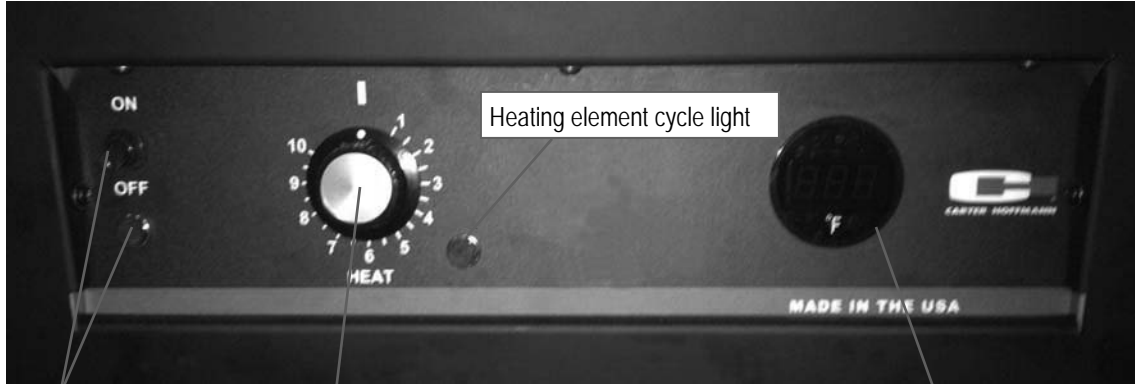

ON/OFF power switch and indicator light

Heat control knob. Settings from 1 (low heat) to 10 (high heat)

Digital temperature read-out

HL2 & HL4 Series Heater/Proofer Cabinets

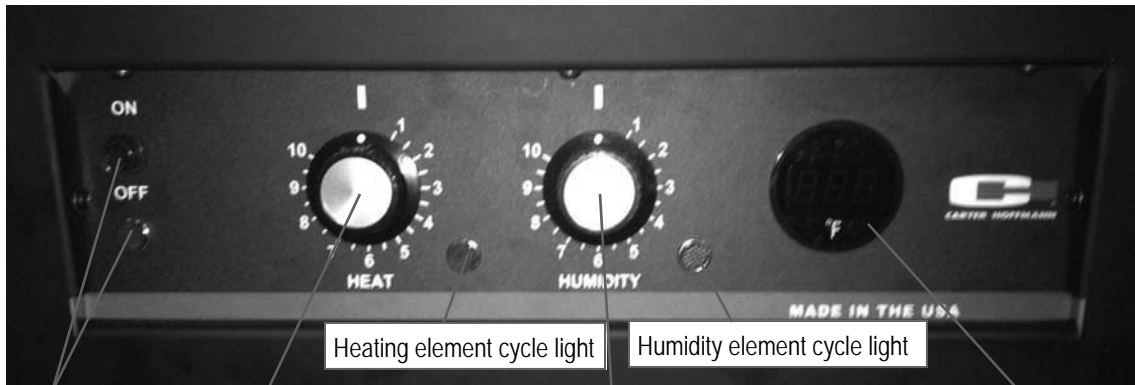

ON/OFF power switch and indicator light

Heat control knob. Settings from 1 (low heat) to 10 (high heat)

Humidity control knob. Settings from 1 (low humidity) to 10 (high humidity)

Digital temperature read-out

WATER PAN LOCATIONS



Humidity pan (HL2 and HL4 cabinets only; manual fill): check and fill every 2 hours when operating cabinet with humidity

Water trough for condensation: collects and deposits condensation into pan below

Condensation pan: check and empty periodically

NORMAL OPERATION—HL1, HL3 & HLM1 HEATED CABINETS



CAUTION: HOT SURFACE

Inner and outer surfaces of the unit will be very hot during and after operation.

Avoid touching the cabinet when loading or removing product.

Operating ranges:

- air temp: 90°F-190°F
(32°C - 88°C)

****For food safety reasons, it is recommended that the holding temperature be set at 140°F (60°C) or higher.***

FIRST USE

Before using the cabinet, familiarize yourself with the heater controls. See page 9 for details. Plug the cabinet into a proven power source. See electrical specifications on page 8.

HOLDING

1. Turn the cabinet on using the power switch located on the far left side of the control panel. Once the switch is turned on, the power indicator light will illuminate.
2. To adjust the temperature setting, rotate the HEAT dial clockwise to increase temperature and counter-clockwise to decrease temperature to the desired set point. Temperature dial settings range from 1 to 10, with 1 being the lowest temperature and 10 being the highest temperature. HEAT cycle light will turn on and off as the heat thermostat cycles.
3. Wait approximately 25 minutes for the cabinet to preheat. Digital readout dial on right side of control panel will display actual cabinet temperature*.
4. Load food pans into cabinet. NOTE: Follow all food safety guidelines. Put hot, cooked food into the cabinet. This cabinet is not intended to reheat food. Food must be cooked and at safe serving temperature prior to being placed in the cabinet.
5. When removing items, start at the bottom and work up. This will keep food hotter and eliminate spillage onto lower items.

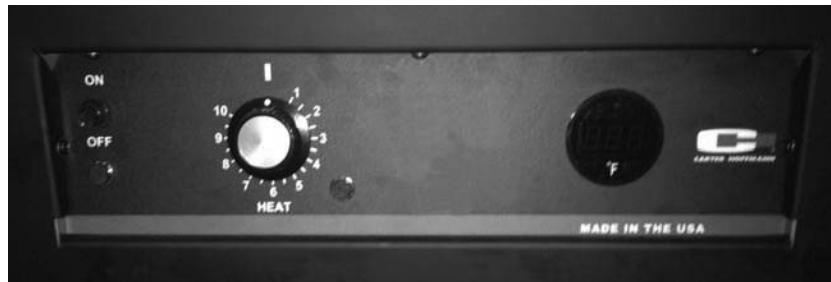

NORMAL OPERATION—HL2 & HL4 HW HEATER PROOFERS



CAUTION: HOT SURFACE

Inner and outer surfaces of the unit will be very hot during and after operation.

Avoid touching the cabinet when loading or removing product.

Operating ranges:

- air temp: 90°F-190°F (32°C to 88°C)
- humidity: 0-90%RH

Water reservoir:

When using the water reservoir for humidified holding or proofing, check water level every 2 hours and refill if needed.



CAUTION: WATER HAZARD

A water trough is located at the base of the cabinet to collect and direct condensation into black plastic condensation pan below. Make sure to periodically check and empty the pan to avoid overflow & slip hazard.

****For food safety reasons, we recommend that the holding temperature should be set at or above 140°F (60°C).***

FIRST USE

Before using the cabinet, familiarize yourself with the heater controls. See page 9 for details. Plug the cabinet into a proven power source. See electrical specifications on page 8.

HOLDING

1. If humidity is desired, a water pan is located at the bottom of the cabinet. This pan will provide active humidification up to 90%RH (depending on temperature). Fill water pan with clean warm water. NOTE: Cabinet may also be operated without water.
2. Turn the cabinet on using the power switch located on the far left side of the control panel. Once the switch is turned on, the power indicator light will illuminate.
3. To adjust the temperature setting, rotate the HEAT dial clockwise to increase temperature and counter-clockwise to decrease temperature to the desired set point. Temperature dial settings range from 1 to 10, with 1 being the lowest temperature and 10 being the highest temperature.
4. To adjust humidity, rotate the humidity dial clockwise to increase humidity and counter-clockwise to decrease humidity. If humidity is not required, rotate dial counter-clockwise to the off position (line up dot on knob with white hash mark on control panel).
5. Wait approximately 25 minutes for the cabinet to preheat. Digital readout dial on right side of control panel will display actual cabinet temperature*.
6. Load food pans into cabinet. NOTE: Follow all food safety guidelines. Put hot, cooked food into the cabinet. This cabinet is not intended to reheat food. Food must be cooked and at safe serving temperature prior to being placed in the cabinet.
7. When removing items, start at the bottom and work up. This will keep food hotter and eliminate spillage onto lower items.

PROOFING

1. Follow instructions above for holding. Note: water pan at base of cabinet must be filled with clean warm water.
2. For proofing settings, rotate HEAT knob clockwise to 5 to 6 (approximately 90°F to 100°F; 32° to 38°C) and rotate HUMIDITY knob clockwise to 10 (90%+ RH).
3. Allow cabinet to preheat for approximately 25 minutes and load food according to the instructions above.



FOOD HOLDING GUIDE



**CAUTION: SAFE
FOOD HOLDING
PRACTICES
RECOMMENDED**

Cooking food to a safe temperature, holding at a temperature of at least 140°F (60°C) is critical in the prevention of foodborne illness. Hold only cooked, hot food at 140°F (60°C) or higher. This cabinet is not intended to cook or reheat food. Food must be at appropriate temperature before being placed into cabinet.

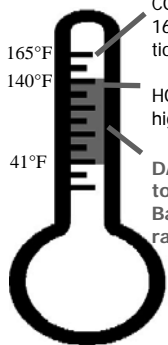

COOK TO AT LEAST
165°F (74°C) Destruction
of most bacteria

HOLD at 140°F (60°C) or
higher

DANGER ZONE: 41°F
to 140°F (5° to 60°C)
Bacteria grow
rapidly

PRODUCT	SET TEMPERATURE (°F / °C)	MAXIMUM TIME (MINUTES)
Bacon, Canadian	180°F / 82°C	30
Bacon, Crisp (uncovered)	180°F / 82°C	30
Baked Potato	180°F / 82°C	60
Biscuits	170°F / 77°C	60
Casseroles	175°F / 79°C	90
Chops, Sliced Meats	160°F / 71°C	60
Chicken, Fried (uncovered)	170°F / 77°C	30
Chicken, Boneless Breasts	175°F / 79°C	60
Chicken Nuggets, Deep Fried (uncovered)	190°F / 88°C	25
Chicken, Pre-Cooked Grilled Boneless Patties	150°F / 66°C	90
Coffee Cakes (uncovered)	170°F / 77°C	60
Cookies (uncovered)	175°F / 79°C	90
Crab Legs	160°F / 71°C	45
Croissants	170°F / 77°C	45
Eggs	160°F / 71°C	45
Fish, Deep-Fried (uncovered)	170°F / 77°C	30
Fish, Baked	155°F / 68°C	45
Fish, Broiled	155°F / 68°C	45
French Toast	165°F / 74°C	60
Gravies / Sauces	170°F / 77°C	45
Hamburgers / Ground Meat Patties	180°F / 82°C	45
Hot Dogs	180°F / 82°C	90
Muffins	170°F / 77°C	60
Omelets	160°F / 71°C	30
Pancakes	180°F / 82°C	30
Pasta	175°F / 79°C	60
Pastries	165°F / 74°C	30
Pizza (uncovered)	180°F / 82°C	15
Pizza (boxed)	180°F / 82°C	60
Poppers, Deep Fried (uncovered)	190°F / 88°C	25
Poultry, Whole, bone-in	175°F / 79°C	60
Poultry, Cut-up, bone-in	175°F / 79°C	60
Ribs	175°F / 79°C	90
Rice	175°F / 79°C	30
Roasts / Bone-in Meats	165°F / 74°C	90
Sausage	180°F / 82°C	90
Shrimp / Shellfish	150°F / 66°C	60
Soups (broth)	185°F / 85°C	90
Tortillas (soft)	180°F / 82°C	60
Vegetables	175°F / 79°C	45

NOTE: Times and temperatures observed in a test kitchen environment. Times and temperatures may vary, depending on initial food quality, initial cooked temperature and user expectations of acceptable food quality.

DAILY CLEANING PROCEDURES



CAUTION: ELECTRIC SHOCK HAZARD

Disconnect appliance from electric power before cleaning.



CAUTION: HOT SURFACE

Exposed surfaces can be hot to the touch and may cause burns. Allow appliance to cool before cleaning.



IMPORTANT:

DO NOT spill or pour water into controls, control panel or wiring. Water damage is **not** covered by warranty.



CAUTION:

Beware of sharp edges with sheet metal during cleaning process.

1. After all food products have been removed from the cabinet, turn the power switch to "OFF" and allow the cabinet to cool completely.
2. Unplug the unit prior to any cleaning.
3. Remove the rack assemblies.
4. Make sure the power cord is not hooked into the cord hook. Open cabinet door and empty water reservoir (HL1 and HL3 cabinets). Remove the heater module by lifting up the front enough to clear its detent, and then pull the module out of the cabinet. The power cord will slide through the access hole at the rear of the cabinet.
5. Inspect and clean the areas where there are vents or filters, making sure no water gets into the internal controls or electrical areas of the cabinet.
6. Clean the inside of the cabinet as well as the removed parts. Reinstall when all parts are dry and clean. Empty and clean black plastic condensation pan.
7. A solution of two tablespoons of baking soda per quart of warm water is sufficient for most cleaning jobs. Mild soap or detergent may be used on heavily soiled interiors—follow manufacturer's directions.
8. For glass doors and windows, clean with window cleaner, taking care not to get any of the solution on the aluminum cabinet walls. Stubborn deposits may be cleaned with a mild soap and water and then rinsed with clean water. Use a soft, non-abrasive cloth to avoid scratching the door.
9. Control panel should be washed with a clean, damp, non-abrasive cloth and chlorine-free detergent. Rinse thoroughly with clean damp cloth and allow to dry. Do not use abrasive cleaners, waxes, car polish, or substances containing strong aromatic solvents or alcohol. If the control knob(s) need to be removed for cleaning, simply pull the knob out, clean the control panel and knob, and then replace the knob.



CAUTION:

Do not use strong detergents, alkalis, ammonia solutions or abrasive cleaners. Use only cleaning agents approved for aluminum and only in the recommended manufacturer's concentration. Do not use steel wool pads—ferrous deposits will cause rusting.

Use of cleaning agents that are not recommended for aluminum may cause permanent damage to the cabinet. **THIS DAMAGE IS PERMANENT, COSTLY TO REPAIR AND IS NOT COVERED BY THE WARRANTY.**

CABINET MAINTENANCE



WARNING:

DO NOT perform these procedures while the cabinet is turned on or heated. Turn off the power and wait for the cabinet to cool to room temperature.



CAUTION:

Do not move cabinet unless door is securely closed. Serious damage to hinges and door may result if bumped into tables, walls, or other equipment when the doors are open.

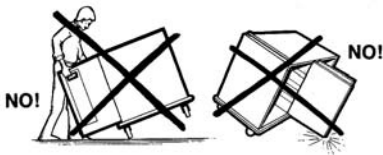

CASTERS

Some cabinets may have caster bearings that are equipped with Zerk grease fittings so that they may be easily lubricated with a grease gun. Lubricate bearings at least once every six months.

HINGE MAINTENANCE

Make sure all joints remain sealed and door latches do not stick. If necessary, use WD-40 to keep door latches from sticking. Do not use oil.

REVERSING THE DOOR

Reversing the door takes about 30 minutes & requires two people.

1. Using a small screwdriver, pry off the hinge covers and set aside. Removing the covers will allow access to the inside hinge screws. Remove the three screws that hold each hinge to the cabinet. **DO NOT REMOVE THE SCREWS THAT HOLD THE HINGES TO THE DOOR.** Remove the door, taking care not to let it fall.
2. Remove the door strike plate and screws adjacent to the door opening on the cabinet. Reinstall door strike plate and screws on opposite side of the cabinet.
3. Screw hinges onto opposite side of the door.
4. With the help of another person, hold door up to the cabinet and attach with the screws removed in step one. Before tightening the screws, be sure the door is flush, level and square. Replace the hinge covers.

WIRING DIAGRAMS

HL1, HL3 & HLM1 HB SERIES

Standard US Electric: 120 VOLT, 1800 WATT, 15AMP, 1 PH, 60 HZ
 International Electric: 220 VOLT, 1800 WATT, 8.2AMP, 1 PH, 50/60 HZ

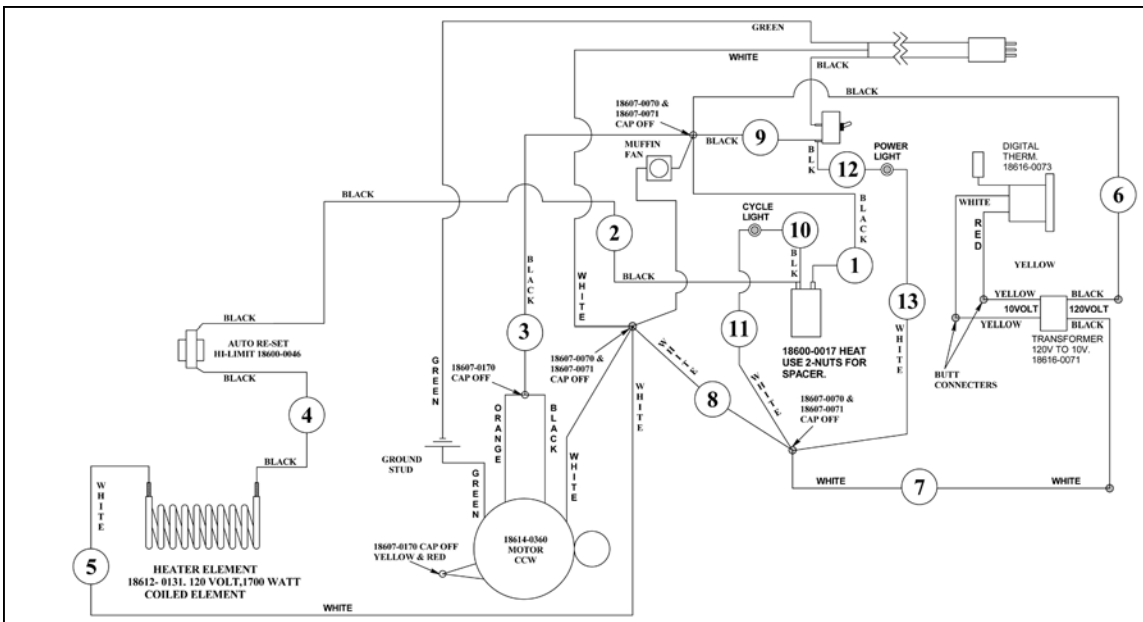

HL2 & HL4 HW SERIES

Standard US Electric: 120 VOLT, 2100 WATT, 17.5 AMP, 1 PH
 International Electric: 220 VOLT, 2100 WATT, 9.5AMP, 1 PH, 50/60 HZ

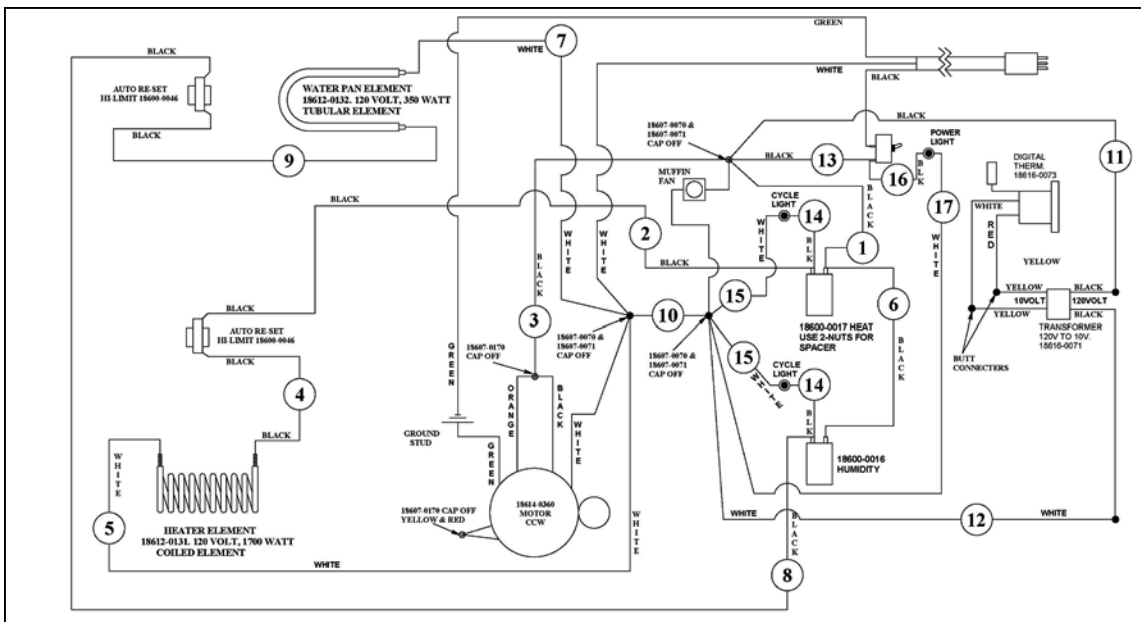

REPLACEMENT PARTS

Use only (OEM) original equipment manufacturer replacement parts. Using unauthorized parts may cause serious injury or damage to the cabinet. Replacement parts should be installed by a qualified service technician.

Contact Carter-Hoffmann with your model and serial number for replacement parts.

Call: 800-323-9793 or

Email: Service@Carter-Hoffmann.com

Part Number	HL1 & HL3 Series Description
18600-0046	Hi limit—open at 300°F, close at 250°F
18602-0083	On/Off switch 20 Amp
18602-0031	Switch boot
18608-0010	Knob—heat
18605-0022	Power cord-8'
18606-0221	5-20P plug
18612-0131	Heat element 1700 watt, 120v (Standard US cabinets)
18613-0136	Heat element 1700 watt, 220v (International cabinets)
18616-0071	Transformer (Standard US cabinets)
18616-0074	Transformer (International 220v cabinets)
18614-0360	Fan motor
18614-0321	Fan motor blower wheel
18314-0019	1.8 qt. black condensation pan
18600-0017	Thermostat
18614-0322	Muffin fan
18616-0073	Digital thermometer
18616-0071	Transformer for digital thermometer
18601-1171	Red indicator light, power and heat
Part Number	HL2 & HL4 Series Description
18600-0046	Hi limit—open at 300°F, close at 250°F
18602-0083	On/Off switch 20 Amp
18602-0031	Switch boot
18608-0010	Knob—heat or humidity
18605-0022	Power cord—8'
18606-0221	5-20P plug
18612-0131	Heat element 1700 watt, 120v (Standard US cabinets)
18613-0136	Heat element 1700 watt, 220v (International cabinets)
18612-0132	Water pan element 350 watt, 120v (Standard US cabinets)
18612-0137	Water pan element 350 watt, 220v (International cabinets)
18616-0071	Transformer (Standard US cabinets)
18616-0074	Transformer (International 220v cabinets)
18614-0322	Muffin fan
18614-0360	Fan motor
18614-0321	Fan motor blower wheel
18314-0019	1.8 qt. black condensation pan
18600-0017	Thermostat—heat element
18600-0016	Thermostat—humidity element
18616-0073	Digital thermometer
18616-0071	Transformer for digital thermometer
18601-1171	Red indicator light, power, heat & humidity

TROUBLESHOOTING GUIDE

SYMPTOM	POSSIBLE CAUSE	SUGGESTED REMEDY
No power on display	Not plugged in or circuit breaker tripped	Check or reset circuit breaker Connect to proper receptacle
	Power cord damaged	Check - replace if required
	Circuit breaker tripped	Check circuit breaker
	Power switch damaged or defective	Check - replace if required
Food dries out too quickly	Operation where product temp is too high; food pans should be covered	Check product temps going into holding cabinet; cover food pans
	Control incorrectly set or defective	Check proper operation or calibration of control
Unit is on, motors are running but no heat	Internal wiring error	Call service technician
	Element hi-limit trip / defective	Call service technician
Takes too long to get to temperature	Improper voltage	Call service technician to verify incoming voltage matches cabinet specifications.
Unit is hot but low or no airflow	Internal wiring error	Call service technician
	Circulation motor has quit	Call service technician
	Improper voltage	Call service technician to verify incoming voltage matches cabinet specifications.

NOTE:

The technical content of this manual, including any wiring diagrams, schematics, parts breakdown illustrations and / or adjustment procedures, is **intended for use ONLY by qualified technical personnel.**

NOTE:

For warranty service, call Carter-Hoffmann direct at 800-323-9793 for authorization, we will dispatch the nearest authorized service agency.

3-YEAR WARRANTY on HOTLOGIX HOLDING CABINETS

Carter-Hoffmann Warranty:

Carter-Hoffmann ("CARTER-HOFFMANN") warrants to the initial purchaser of its standard Carter Line Products that CARTER-HOFFMANN will, at its option, repair or replace, during the warranty period set forth below, any part of such products made necessary due to a defect in material or workmanship which is present when the product leaves its factory and which manifests itself during the warranty period under normal use and service.

This warranty applies only to original equipment owned and possessed by the initial purchaser and the warranty period begins on the date of original shipment from the CARTER-HOFFMANN factory and extends as follows: to component parts and labor for 12 months (36 months on hotLOGIX holding cabinets, levels 3 through 10, and cook & hold cabinets); to refrigeration compressor unit for one year (limited to replacement only - not to include labor for removal, repair or replacement).

Repair or replacements under this warranty will be performed, unless otherwise authorized in writing by CARTER-HOFFMANN, at its factory. All parts or components to be repaired or replaced under this warranty are to be shipped prepaid to CARTER-HOFFMANN, with reimbursement credit for such part or component to be given if found by CARTER-HOFFMANN to be defective.

CARTER-HOFFMANN neither makes nor assumes and does not authorize any other person to make or assume any obligation or liability in connection with its products other than that covered in this warranty. This warranty applies only within the continental United States and Canada. In Alaska and Hawaii, this warranty applies only to and is limited to the supply of replacement parts.

Warranty Exclusions and Limitations:

Any implied warranty of merchantability or fitness for a particular purpose is hereby specifically disclaimed by CARTER-HOFFMANN. There are no warranties, expressed or implied, which extend beyond the description on the face hereof. This warranty does not cover and CARTER-HOFFMANN shall not under any circumstances be liable for any incidental, consequential or other damages (such as injury to persons or property, loss of time, inconvenience, loss of business or profits, or other matters not specifically covered) arising in connection with the use of, inability to use, or failure of these products.

Specifications subject to change through product improvement and innovation.

Carter-Hoffmann

1551 McCormick Ave.

Mundelein, Illinois, 60060 USA

Phone: 847-362-5500 Toll free: 800-323-9793 Fax: 847-367-8981

Sales and Marketing E-mail: sales@carter-hoffmann.com

Service E-mail: technicalservice@carter-hoffmann.com

Company Website: www.carter-hoffmann.com



Proud Member

