

HUMIDIFIED HOLDING & TRANSPORT CART

MODEL: HTU12

OWNERS / OPERATORS MANUAL



MANUFACTURED BY:

CARTER-HOFFMANN
1551 McCormick Avenue
Mundelein, IL 60060 U.S.A.

Phone: 847-362-5500

Fax: 847-367-8981

Toll Free: 800-323-9793

Email: technicalservice@carter-hoffmann.com



TABLE OF CONTENTS

SAFETY PRECAUTIONS.....	2
FEATURES & SPECIFICATIONS.....	3
UNPACKING, INSPECTION & FREIGHT DAMAGE.....	4
INSTALLATION & STARTUP	5
CONTROL PANEL LAYOUT.....	6
NORMAL OPERATION.....	7
FOOD HOLDING GUIDE.....	8
REGULAR CLEANING PROCEDURES.....	9
CABINET MAINTENANCE & REPLACEMENT PARTS.....	10
WIRING DIAGRAM.....	11
TROUBLESHOOTING GUIDE	12
WARRANTY STATEMENT.....	13

SAFETY PRECAUTIONS



WARNING: ELECTRIC SHOCK HAZARD

All service requiring access to non-insulated components must be performed by qualified service personnel. Failure to heed this warning may result in severe electric shock.



CAUTION: ELECTRIC SHOCK HAZARD

Disconnect this appliance from electrical power before performing any maintenance or service.



CAUTION: BURN HAZARD

Exposed metal surfaces can be hot to the touch and may cause burns.



CAUTION: STEAM HAZARD

This cabinet produces steam and may cause burns. Use caution when opening the doors for escaping steam.

IMPORTANT SAFETY INSTRUCTIONS

When using electrical appliances basic safety precautions should be adhered to, including the following:

- 1) Be familiar with the appliance use, limitations and associated restrictions. Operating instructions must be read and understood by all persons using or installing this appliance.
- 2) This appliance must be grounded. Connect only to properly grounded outlet.
- 3) Use this appliance only for its intended purpose as described in the manual.
 - a. This equipment is specifically designed to hold pre-cooked food at temperature.
 - b. This equipment is intended for use in commercial establishments only.
 - c. This equipment is not designed for industrial or laboratory use.
- 4) Cleanliness of this appliance and its accessories is essential to good sanitation.
- 5) DO NOT submerge this appliance in water. This appliance is not jet stream approved. DO NOT direct water jet or steam jet at this appliance, or at any control panel or wiring. DO NOT splash or pour water on, in or over any controls, control panel or wiring. DO NOT use corrosive chemicals or vapors in this appliance.
- 6) DO NOT store or use this appliance outdoors. DO NOT use this product near water – for example, near a kitchen sink, in a wet basement, or near a swimming pool, and the like.
- 7) DO NOT operate this appliance if it has a damaged cord or plug, if it is not working properly, or if it has been damaged or dropped. Do not immerse cord or plug in water, keep cord away from heated surfaces, and do not let cord hang over edge of table or counter.
- 8) DO NOT cover or block any openings on the appliance.
- 9) **Only qualified service personnel should service this appliance.**

NOTE: The technical content of this manual, including any wiring diagrams, schematics, parts breakdown illustrations and/or adjustment procedures, is **intended for use by qualified technical personnel** and is subject to change without notice.

FEATURES & SPECIFICATIONS



- Precision-engineered with fan for even heat and humidity.
- Humidity from low to high: dial settings from 1 to 7. Temperature range of 90°F - 200°F.
- Simple dial controls for heat and humidity. Easy dial temperature readout.
- Can be operated with or without humidity.
- All swivel heavy-duty casters, front casters fitted with brakes.
- Full perimeter wrap-around bumper set in extruded aluminum frame
- Stainless steel insulated door
- Bottom-mounted water reservoir
- Under-cabinet condensation pan
- Adjustable universal stainless steel pan slides are standard; standard spacing at 4.5". Adjustable on 1.5" centers

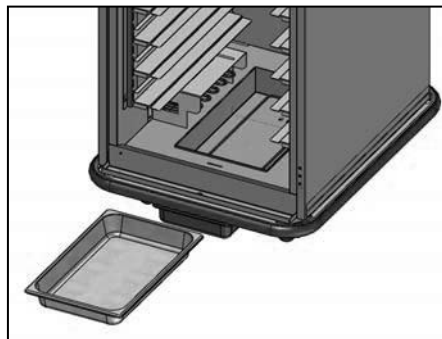
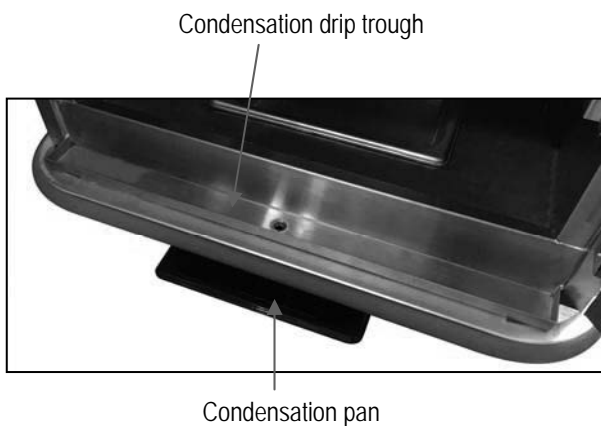

Model Number	Tray Capacity*		Slide Pairs Provided	Inside Working Height in (mm)	Overall Dimensions			Caster Diameter in (mm)	Class 100 Shipping Weight lbs (kg)
	12" x 20"	18" x 26"			Height	Depth in (mm)	Width		
HTU12	24	12	12	60 (1524)	74-3/4 (1899)	36-3/8 (924)	29-7/8 (759)	5 (127)	281 (127)

Electrical Information NEMA Plug Type	
1700 W 120V 14.2 Amp 60 Hz Single Phase	NEMA 5-15P



UNPACKING AND INSPECTION



This appliance should be thoroughly cleaned prior to use.

See the **CLEANING INSTRUCTIONS** in this manual.

NOTE: DO NOT discard the carton or other packing materials until you have inspected the appliance for hidden damage and checked it for proper operation.

Refer to **FREIGHT DAMAGE CLAIM PROCEDURE** on bottom of this page.

1. Remove the cabinet from shipping carton, ensuring that all packing materials and protective plastic have been removed from the unit.
2. Inspect all components for completeness and condition.
 - tray racks: Qty 4; two on each side of the cabinet. Cabinets will include a separate box of universal tray slides.
 - condensation drip pan
1. If any freight damage is present, a freight claim must be filed immediately with the shipping company.
2. **Freight damage is not covered under warranty.**
3. Check to insure all components are included: cabinet, instruction packet and stainless steel water trough.
4. Read operation instructions completely.
5. Appliance should be thoroughly cleaned before use. See **CLEANING INSTRUCTIONS** in this manual.

FREIGHT DAMAGE PROCEDURE

NOTE: For your protection, please note that equipment in this shipment was carefully inspected and packaged by skilled personnel before leaving the factory. Upon acceptance of this shipment, the transportation company assumes full responsibility for its safe delivery.

IF SHIPMENT ARRIVES DAMAGED:

1. **VISIBLE LOSS OR DAMAGE:** Be certain that any visible loss or damage is noted on the freight bill or express receipt, and that the note of loss or damage is signed by the delivery person.
2. **FILE CLAIM FOR DAMAGE IMMEDIATELY:** Regardless of the extent of damage. **Contact your dealer immediately.**
3. **CONCEALED DAMAGE:** If damage is unnoticed until the merchandise is unpacked, notify the transportation company or carrier immediately, and then file a "CONCEALED DAMAGE" claim with them. This should be done within fifteen (15) days from the date the delivery was made to you. **Be sure to retain the container for inspection.**

Carter-Hoffmann cannot assume liability for damage or loss incurred in transit, **freight damage is not covered under warranty.** We will, however, at your request, supply you with the necessary documents to support your claim.

GROUNDING INSTRUCTIONS

This appliance is equipped with a cord having a grounding wire with a grounding plug which must be plugged into an outlet that is properly installed and grounded. In the event of an electrical short circuit, grounding reduces the risk of electric shock by providing an escape wire for the electric current.

WARNING—Improper use of the grounding can result in a risk of electric shock. Consult a qualified electrician or service agent if the grounding instructions are not completely understood, or if doubt exists as to whether the appliance is properly grounded.

INSTALLATION and STARTUP



WARNING: Risk of personal injury

Installation procedures must be performed by a qualified technician with full knowledge of all applicable electrical codes. Failure could result in personal injury and property damage.



IMPORTANT: Not under warranty

Damage to unit due to being connected to the wrong voltage or phase is **NOT** covered by warranty. If necessary, contact a licensed electrician to install an appropriate 20 amp electrical circuit with correct NEMA receptacle. Power cord is 10' long. **DO NOT use an extension cord.**

Electrical Information NEMA Plug Type	
1685 W	NEMA 5-15P
120V	
14 Amp	
60 Hz	
Single Phase	



CAUTION: Electrical Shock Hazard

The ground prong of the power cord is part of a system designed to protect you from electric shock in the event of internal damage.

DO NOT cut off the large round ground prong or twist a blade to fit an existing receptacle.



CAUTION: Electrical Shock Hazard

Unit is not waterproof, to avoid electrical shock, keep unit and counter from being submerged in water. Do not operate if unit has been in contact with water.

LOCATION

For proper operation and maximum performance, locate the unit in an ambient air temperature of 70°F (21°C).

Avoid placement in areas near exhaust fans or where there are active air movements.

For safe operation and maximum performance, locate the unit at least 2" from any wall or combustible material.

Unit must be on a solid level surface.

STARTUP

1. Prior to use, thoroughly clean the interior of the unit and the water reservoir, per the instructions in this manual.

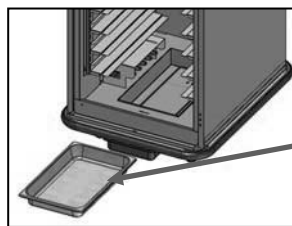

Water reservoir

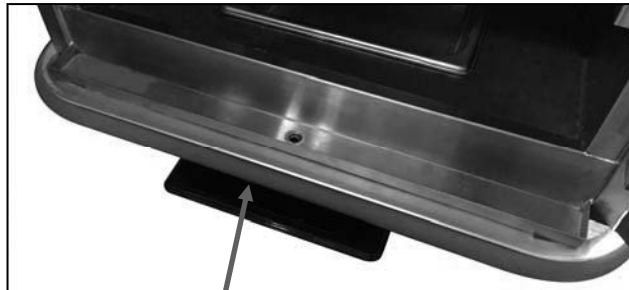

2. Install condensation pan under the base of the cabinet. It slides into the rails located under the water trough.
3. Install the universal pan slides in each tray rack located at each side of the cabinet. Standard spacing is every third slot (4.25" apart). Begin with the lowest slot at the bottom of the cabinet and work your way up. Hold the slide at an angle and line up the tabs at either end with the slots in the tray rack. Slide the tabs into the slots, then tilt the slide down so that it is level.
4. Plug the power cord of the cabinet into a grounded outlet with a minimum 15 A, 120Vac, 60Hz, single phase electrical service.
5. Set POWER switch to the "ON" position.
6. Set temperature dial to 190°F. Do not fill humidity pan. Set humidity dial to off.
7. Do not load product into the cabinet. Allow the heat to remove any residual oils which may adhere to inside metal surfaces. A slight emission of smoke is common during the first few hours of operation.

Control panel layout

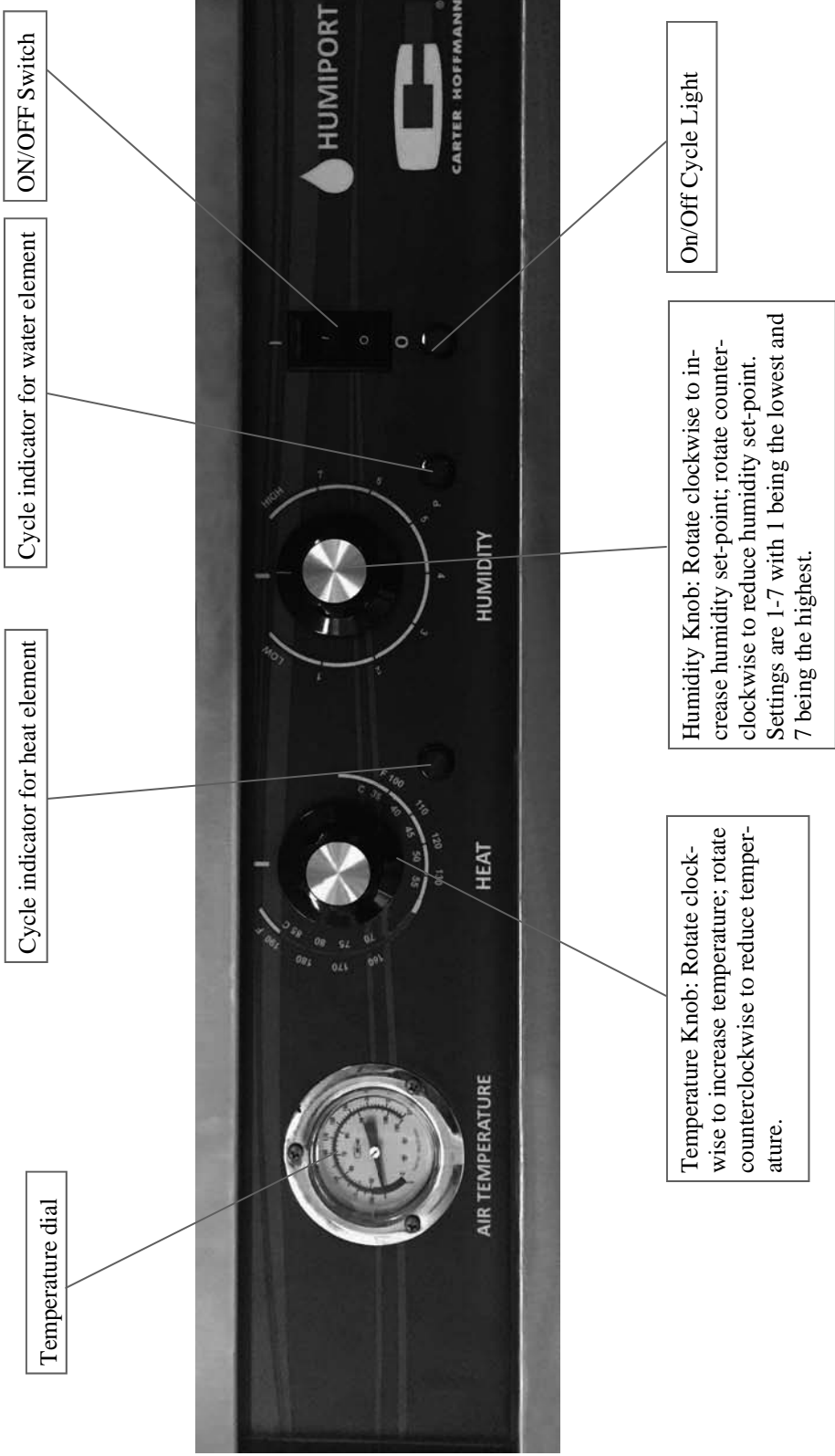

NORMAL OPERATION



CAUTION: HOT SURFACE

Inner surfaces of the unit will be very hot during and after operation.

Avoid touching the cabinet when loading or removing product.

Operating ranges:

- air temp: 85°F-200°F
- humidity: OFF-90%



CAUTION: STEAM HAZARD

This unit produces steam, use caution when cleaning or opening the doors.



CAUTION: WATER HAZARD

A condensation pan is located under the cabinet to collect condensation. Make sure to periodically check and empty it regularly to avoid overflow.

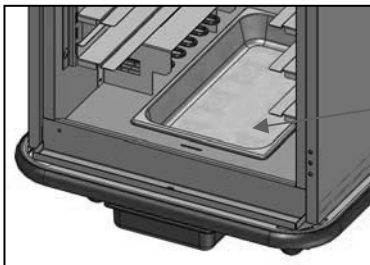

Water reservoir located at bottom of cabinet interior.

To fill, pour water into the reservoir.

The HTU12 Series Humidified Holding Cabinet is equipped with two dials to control the temperature and humidity settings. Before using, familiarize yourself with the cabinet controls. See detail on page six of this manual.

This holding cabinet is equipped with an active air flow and humidity system. Warm air flows over the water that is heated by an element in the reservoir and is circulated throughout the cabinet. As the cabinet maintains the desired humidity level, water will be used from the reservoir. To maintain desired humidity, replenish water supply in reservoir when necessary. Monitor water level in condensation collection pan under the cabinet and empty when full.

HOLDING

1. Fill water reservoir with **WARM WATER** if humidity is desired (cabinet may also be operated without humidity). Watch water level in water pan. Do not overfill. Approximate capacity:

HTU12: 1.75 gallons

2. Turn cabinet on and set temperature and humidity dials to desired settings. Allow cabinet to preheat for 45 minutes.
3. Load cabinet with pans or trays. Load from bottom to top for best results.
4. When removing items, start at the bottom and work to the top. This keeps food hotter and eliminates spillage onto lower items.

Due to food safety concerns, we recommend that the holding temperature should not be set below 140°F.

PROOFING

1. Fill water reservoir with **WARM WATER**. Watch water level in water pan. Do not overfill. Approximate capacity:

HTU12: 1.75 gallons

2. Turn cabinet on. Set temperature dial to lowest setting and humidity to 7. Allow cabinet to preheat for 45 minutes.
3. Load cabinet with pans or trays. Load from bottom to top for best results.
4. Proof according to your recipe instructions.
5. When removing items, start at the bottom and work to the top. This keeps food hotter and eliminates spillage onto lower items.

FOOD HOLDING GUIDE



**CAUTION: SAFE
FOOD HOLDING
PRACTICES
RECOMMENDED**

Cooking food to a safe temperature, holding at a temperature of at least 140° F is critical in the prevention of foodborne illness. Hold only cooked, hot food at 140°F or higher. This cabinet is not intended to cook or reheat food. Food must be at appropriate temperature before being placed into cabinet.

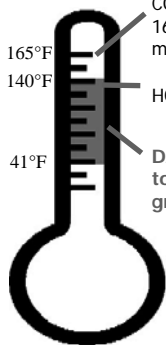

COOK TO AT LEAST
165°F Destruction of
most bacteria

HOLD at 140°F or higher

**DANGER ZONE: 41°F
to 140°F** Bacteria
grow rapidly

PRODUCT (Uncovered Food, except where noted)	SET TEMPERA- TURE (°F / °C)	RELATIVE HUMIDITY %	MAXIMUM TIME (MINUTES)
Bacon, Canadian	180°F / 82°C	50%	30
Bacon, Crisp	180°F / 82°C	NONE REQUIRED	30
Baked Potato	180°F / 82°C	60%	60
Biscuits	170°F / 77°C	20%	60
Casseroles (Covered)	175°F / 79°C	NONE REQUIRED	90
Chops, Sliced Meats	160°F / 71°C	45%	60
Chicken, Fried	170°F / 77°C	NONE REQUIRED	30
Chicken, Boneless Breasts	175°F / 79°C	75%	60
Chicken Nuggets, Deep Fried	190°F / 88°C	NONE REQUIRED	25
Chicken, Pre-Cooked Grilled Boneless Patties	150°F / 66°C	55%	90
Coffee Cakes	170°F / 77°C	MINIMAL	60
Cookies	175°F / 79°C	NONE REQUIRED	90
Crab Legs	160°F / 71°C	80%	45
Croissants	170°F / 77°C	30%	45
Eggs	160°F / 71°C	90%	45
Fish, Deep-Fried	170°F / 77°C	NONE REQUIRED	30
Fish, Baked	155°F / 68°C	80%	45
Fish, Broiled	155°F / 68°C	70%	45
French Toast	165°F / 74°C	30%	60
Gravies / Sauces	170°F / 77°C	85%	45
Hamburgers / Ground Meat Patties	180°F / 82°C	55%	45
Hot Dogs	180°F / 82°C	70%	90
Muffins	170°F / 77°C	20%	60
Omelets	160°F / 71°C	90%	30
Pancakes	180°F / 82°C	60%	30
Pasta	175°F / 79°C	75%	60
Pastries	165°F / 74°C	20%	30
Pizza (uncovered)	180°F / 82°C	10%	30
Pizza (boxed)	180°F / 82°C	NONE REQUIRED	60
Poppers, Deep Fried	190°F / 88°C	NONE REQUIRED	25
Poultry, Whole, bone-in	175°F / 79°C	55%	60
Poultry, Cut-up, bone-in	175°F / 79°C	75%	60
Ribs	175°F / 79°C	60%	90
Rice	175°F / 79°C	70%	30
Roasts / Bone-in Meats	165°F / 74°C	60%	90
Sausage	180°F / 82°C	50%	90
Shrimp / Shellfish	150°F / 66°C	80%	60
Soups (broth)	185°F / 85°C	NONE REQUIRED	90
Tortillas (soft)	180°F / 82°C	70%	60
Vegetables	175°F / 79°C	70%	45

NOTE: Times and temperatures observed in a test kitchen environment. Times and temperatures may vary, depending on initial food quality, initial cooked temperature and user expectations of acceptable food quality.

DAILY CLEANING PROCEDURES



**CAUTION:
ELECTRIC SHOCK
HAZARD**

Disconnect appliance from electric power before cleaning.



**CAUTION:
HOT SURFACE**

Exposed surfaces can be hot to the touch and may cause burns. Allow appliance to cool before cleaning.



IMPORTANT:

DO NOT spill or pour water into controls, control panel or wiring. Water damage is **not** covered by warranty.



**CAUTION:
STEAM HAZARD**

Cabinet generates steam, use caution when opening doors to clean unit.



CAUTION:

Beware of sharp edges with sheet metal during cleaning process.

1. After all food products have been removed from the cabinet, turn the power switch to "OFF" and allow the cabinet to cool.
2. Unplug the unit prior to any cleaning.
3. Remove and clean the water pan from the inside bottom of the cabinet. Caution, water may still be hot from prior use. A vinegar & water solution may be used to remove stubborn mineral deposits. Remove and clean the condensation collection pan mounted to the bottom of the unit.
4. Remove the slide racks. Clean the inside of the unit as well as the removed parts. Reinstall when all parts are dry and clean.
5. Take care to ensure that no water comes into contact with the internal controls or electrical areas of the cabinet.
6. Plastic control panel should be washed with a clean damp cloth and chlorine-free detergent. Rinse thoroughly with clean damp cloth and allow to dry. Do not use abrasive cleaners, waxes, car polish, or substances containing strong aromatic solvents or alcohol.



CAUTION: Cleansers, detergents, degreasers, sanitizers, or bleaching agents that contain chlorides or phosphates will cause permanent damage to stainless steel products. The damage appears as pits, eruptions, voids, small holes, severe discoloration or dulling of the metal finish.

Water with high chloride content can also damage stainless steel. If unsure of your water quality, we recommend you have it tested. **THIS DAMAGE IS PERMANENT, COSTLY TO REPAIR, AND IS NOT COVERED BY THE WARRANTY.**

RECOMMENDED TIPS FOR CLEANING STAINLESS STEEL

<u>Purpose</u>	<u>Frequency</u>	<u>Cleaning Agent</u>	<u>Method of Application</u>
Routine cleaning	Daily	Soap, ammonia detergent and water	Sponge with cloth, rinse with clear water and wipe dry.
Smears/ Fingerprints	As needed	Stainless steel cleaner or similar products	Rub with soft cloth as directed on package. Rub in direction of grain of stainless steel. Do not use on vinyl trim.
Stubborn spots and stains	Daily as needed	Any chloride-free or phosphate-free cleaner	Apply with damp sponge or cloth. Rub in direction of grain of stainless steel. Rinse thoroughly, especially if cleaner contains chlorine bleach, do not use on vinyl trim.
Hard water spots	Daily as needed	Vinegar	Swab with cloth. Rinse with water and wipe dry.

CABINET MAINTENANCE



WARNING:

DO NOT perform these procedures while the cabinet is turned on or heated. Turn off the power and wait for the cabinet to cool to room temperature.



CAUTION:

Do not move cabinet unless door is securely closed. Serious damage to hinges and door may result if bumped into tables, walls, or other equipment when the doors are open.

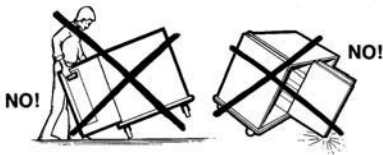

CASTERS

Caster bearings are equipped with Zerk grease fittings so that they may be easily lubricated with a grease gun. Lubricate bearings at least once every six months.

REPLACING THE DOOR GASKET

1. Remove the screws located under the gasket on the cabinet.
2. Remove the gasket and discard.
3. Install the new gasket and replace the screws.

REPLACEMENT PARTS



Use only (OEM) original equipment manufacturer replacement parts. Using unauthorized parts may cause serious injury. Replacement parts should be installed by a qualified service technician.

Contact factory with your model and serial number for replacement parts.

Part Number Description

Part Number	Description
17020-2294	Door gasket
18600-0046	Hi limit-300°F; water and air
18600-0137	Humidity stat
18600-0129	Thermostat
18601-1171	Red power indicator light
18602-0289	ON/OFF Switch
18603-0037	Fan motor
18603-5017	Fan blade (for motor 18603-0037)
18603-5021	Motor cooling fan
18605-0016	Power cord with NEMA 5-15P plug
16505-7080	Drip pan
18314-0040	Stainless steel water reservoir pan
18612-0151	Heat element 350 W (water reservoir)
18612-0425	Heat element 1300 W (air)
18616-0014	Dial thermometer
18616-9998	Cord grip
29034-0282	Silicone sponge seal

For units with CE certification 18600-0046 is replaced with:

18600-0136	Jumo hi limit; 1000 mm lead (water)
18600-0135	Jumo hi limit; 100 mm lead (air)

WIRING DIAGRAM

HTU12 WITH ANALOG CONTROL
120 VOLT, 1700 WATT, 14.2 AMP, 1 PH, 60 HZ

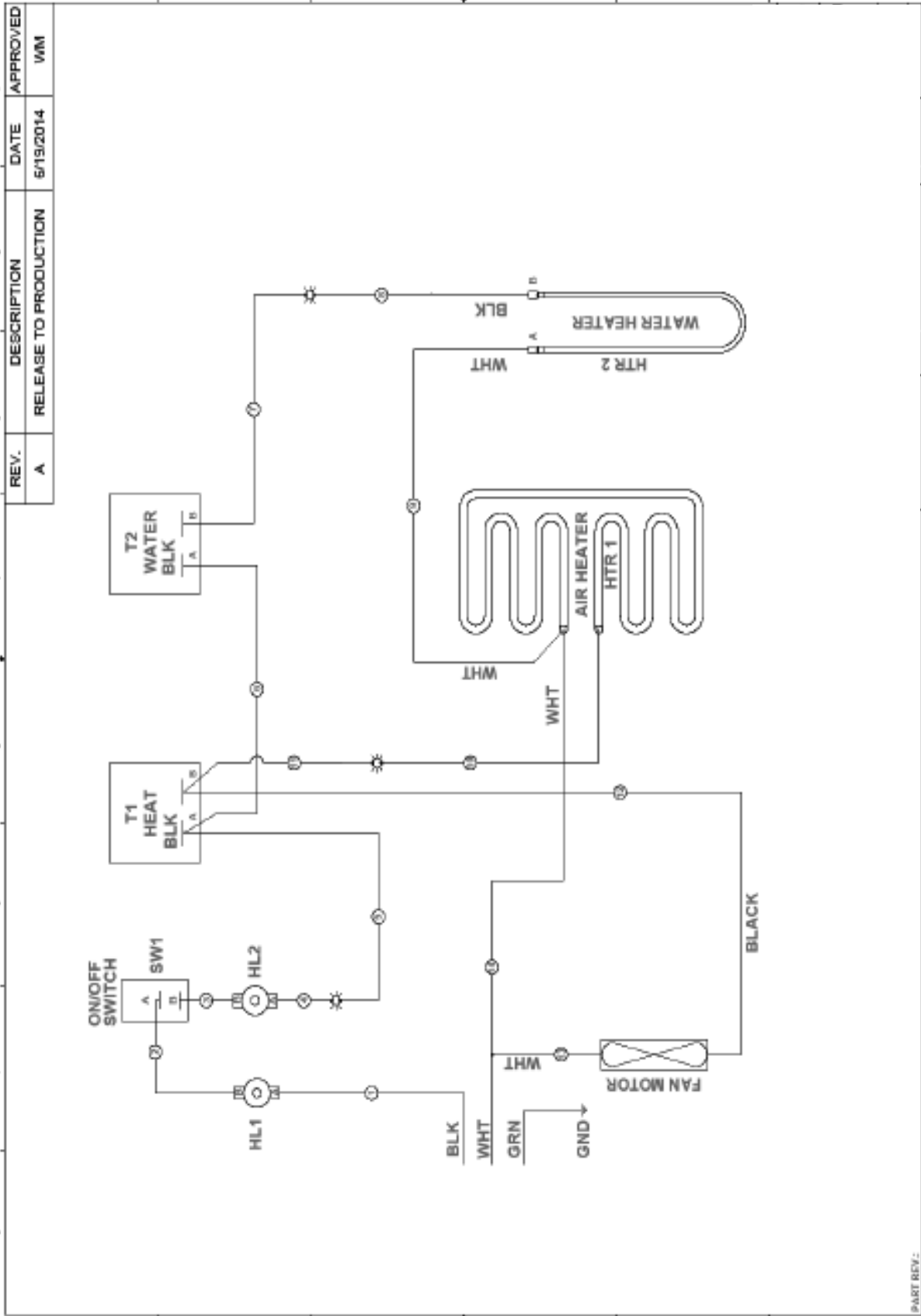

PART REV.:

TROUBLESHOOTING GUIDE

SYMPTOM	POSSIBLE CAUSE	SUGGESTED REMEDY
No power on display	Not plugged in or circuit breaker tripped	Check or reset circuit breaker Connect to proper receptacle
	Power cord damaged	Check - replace if required
	Power switch damaged or defective	Check - replace if required
Food dries out too quickly/humidity too low	Operation where product temp is too high	Check product temps going into holding cabinet
	Control incorrectly set or defective	Check proper operation or calibration of control
	Intermediate switch failure	Call service technician
	Hi limit trip / defective	Call service technician
Unit is on, motors are running but no heat	Heating element failed	Call service technician
	Element hi-limit trip / defective	Call service technician
Unit is hot but low or no airflow	Thermostat defective	Call service technician
	Circulation motor has quit	Call service technician
	Improper voltage	Call service technician to verify incoming voltage matches cabinet specifications.

NOTE:

The technical content of this manual, including any wiring diagrams, schematics, parts breakdown illustrations and / or adjustment procedures, is **intended for use ONLY by qualified technical personnel.**

NOTE:

For warranty service, call Carter-Hoffmann direct at 800-323-9793 for authorization, we will dispatch the nearest authorized service agency.

WARRANTY

Carter-Hoffmann Warranty:

Carter-Hoffmann ("CARTER-HOFFMANN") warrants to the initial purchaser of its standard Carter Line Products that CARTER-HOFFMANN will, at its option, repair or replace, during the warranty period set forth below, any part of such products made necessary due to a defect in material or workmanship which is present when the product leaves its factory and which manifests itself during the warranty period under normal use and service.

*This warranty applies only to original equipment owned and possessed by the initial purchaser and the warranty period begins on the date of original shipment from the CARTER-HOFFMANN factory and extends as follows: **to component parts and labor for 12 months (36 months on hotLOGIX holding cabinets and cook & hold cabinets) ; to refrigeration compressor unit for one year (limited to replacement only - not to include labor for removal, repair or replacement).***

Repair or replacements under this warranty will be performed, unless otherwise authorized in writing by CARTER-HOFFMANN, at its factory. All parts or components to be repaired or replaced under this warranty are to be shipped prepaid to CARTER-HOFFMANN, with reimbursement credit for such part or component to be given if found by CARTER-HOFFMANN to be defective.

CARTER-HOFFMANN neither makes nor assumes and does not authorize any other person to make or assume any obligation or liability in connection with its products other than that covered in this warranty. This warranty applies only within the continental United States and Canada. In Alaska and Hawaii, this warranty applies only to and is limited to the supply of replacement parts.

Warranty Exclusions and Limitations:

Any implied warranty of merchantability or fitness for a particular purpose is hereby specifically disclaimed by CARTER-HOFFMANN. There are no warranties, expressed or implied, which extend beyond the description on the face hereof. This warranty does not cover and CARTER-HOFFMANN shall not under any circumstances be liable for any incidental, consequential or other damages (such as injury to persons or property, loss of time, inconvenience, loss of business or profits, or other matters not specifically covered) arising in connection with the use of, inability to use, or failure of these products.

Specifications subject to change through product improvement and innovation.

Carter-Hoffmann

1551 McCormick Ave.

Mundelein, Illinois, 60060 USA

Phone: 847-362-5500 Toll free: 800-323-9793 Fax: 847-367-8981

Sales and Marketing E-mail: sales@carter-hoffmann.com

Service E-mail: technicalservice@carter-hoffmann.com

Company Website: www.carter-hoffmann.com

CFESA

Proud Member

NAFEM
North American Association of
Food Equipment Manufacturers