

Cleaning, Operating, Maintenance Instructions, Parts List & Warranty



CARTER-HOFFMANN CORP.

NOTE:

This equipment has been designed and manufactured to meet aU applicable health and safety codes and will give years of dependable service if used properly. This cart should be thoroughly cleaned before it is used.

Heated Carts with TH15 Top Mount Heater

Models Include:

PH188, PH1820, PH1840

with flush door

PH1835 with

non-flush door

1. Before cleaning, unplug heating unit.
2. Racks or shelves are easily removed without tools for cleaning. Simply lift up and pull out. The tray slides may be hand washed or run through an automatic washer.
3. If applicable, vinyl trim or laminate should be washed with a chlorine-free detergent and water. Rinse thoroughly with clear water and allow to dry. Never use abrasive cleaners, waxes, car polish or substances containing strong aromatic solvents or alcohol. Caution: When using solvents, it is essential that proper precautionary measures be observed. Refer to solvent manufacturer's instructions. Use of direct **steam/hot water** cleaning at temperatures above **190°F** may result in "bubbling" or loosening of vinyl adhesive.
4. To clean stainless steel surfaces use only cleansers, detergents, degreasers, or sanitizers that are certified to be "chloride-free" and "phosphate-free," and cleansers, degreasers, or sanitizers only in the recommended concentrations. **DO NOT** exceed recommended concentrations or mixing ratios. After cleaning and sanitizing, rinse all exposed surfaces thoroughly with large amounts of clean, clear water. Wipe off any standing liquid or residue from all surfaces, corners, or near edges,

Cleaning Instructions



The heater should not be exposed to direct contact with

WARNING *water or cleaning sprays. Permanent damage to the electrical components will result.*



Cleansers, detergents degreasers, sanitizers, or bleaching agents

CAUTION *that contain chlorides or phosphates will cause permanent damage to stainless steel products. The damage appears as pits, eruptions, voids, small bores, cracks, severe discoloration, or dulling of the metal finish. Water with high chloride content can also damage stainless steel. If unsure of your water quality, we recommend you have it tested. THIS DAMAGE IS PERMANENT, COSTLY TO REPAIR, IS NOT COVERED BY THE*

RECOMMENDED "TIPS" FOR CLEANING STAINLESS STEEL

Purpose	Frequency	Cleaning Agent	Method of Application
Routine cleaning	Daily	Soap, ammonia detergent and water	Sponge with cloth, rinse with clear water and wipe dry.
Smears/ fingerprints	As Needed	Vista, Stainless Shine or similar products	Rub with cloth as directed on package. Rub in direction of grain of stainless steel. Do not use on vinyl trim.
Stubborn spots and stains	Daily As Needed	Household cleaners or Goddards Stainless Steel Care. Revere Stainless Cleaner or similar products.	Apply with damp sponge or cloth. Rub in direction of polish lines. Rinse thoroughly after use, especially if cleaner contains chlorine bleach. Do not use on vinyl trim.
Hard water spots	Daily As Needed	Vinegar	Swab with cloth. Rinse with water and wipe dry.



CAUTION: *Do not use steel wool pads as they will result in rusting from the ferrous metal in the pads.*

Heater/Cabinet Operations

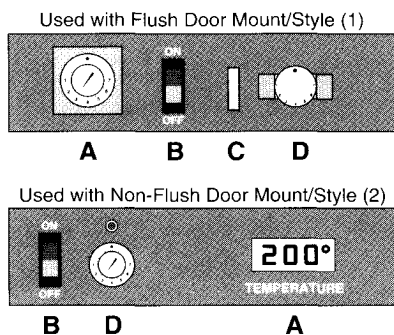

NOTE:

This unit is designed/or HOLDING hot foods. To insure best results, be sure your food containers and covers are at or above the desired holding temperature and the cabinet is completely pre-heated.

1. Familiarize yourself with the heater controls.
 - A. Dial Thermometer/Digital Thermometer
 - B. On/Off Switch
 - C. White Indicator Light/Red Indicator Light
 - D. Thermostat
2. Plug heater into a proper power source. Remove water pan from interior of cabinet, fill halfway with warm water and return to cart.
3. Turn power switch on. The fan motor will operate continuously. The white indicator light will cycle with the heat element.
4. To pre-heat the cabinet, turn the thermostat to "7" and heat for 45 minutes. Be sure the cabinet door is closed securely.
5. Food serving temperature will vary with the mass, type and quantity of food served. Set the thermostat for the desired hold setting. Clockwise to increase the temperature and counter-clockwise to decrease the temperature.
6. During loading, the cabinet temperature will drop. Try not to move the cabinet right away; wait 10-15 minutes until the cabinet recovers air temperature.
7. Be sure to remove the plug from the outlet and wind the cord on the cord bracket or push handle before moving the cart. Move the cart to the service area as quickly as possible.
8. Upon reaching the serving area, unwind the power cord and reconnect the heater as quickly as possible. Wait 5-10 minutes (check the thermometer to see if the temperature is at the desired level). If not; adjust the thermostat as required.
9. When removing items, start at the bottom and work to the top position This keeps food hotter and eliminates spillage on lower items.

Calibrations

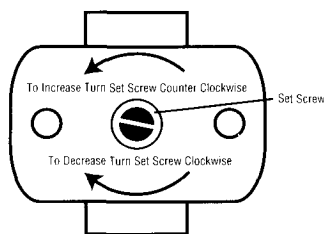
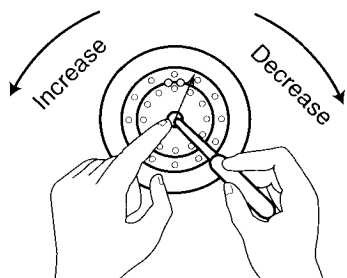

[A] THERMOMETER CALIBRATION

Place an oven thermometer in the center of the cabinet. Turn heater on; turn thermostat to maximum setting and wait approximately 45 minutes. Open the door and check inside thermometer temperature. If recalibration is required, pry the plastic cover off the dial body and with a small flat blade screwdriver insert into the pointer as shown. Carefully turn the pointer with your finger to the correct setting. Be careful not to bend the pointer, it is very fragile.

[B] THERMOSTAT CALIBRATION

If additional heat range is required in the heating unit, unplug unit, remove black thermostat knob, insert small straight blade screwdriver into opening and turn limit control set screw **counter clockwise** one full turn. Replace thermostat knob and turn clockwise to reach new maximum temperature. Repeat this until desired temperature is reached. Each 1/4 turn of the calibration set screw will raise the element heating capacity by approximately 25-35T.

If a reduction of heat is desired, turn limit control set screw **clockwise** one full turn. Hold the door open allowing unit to cool until inside temperature is below the temperature desired. Close the door and allow unit to rise to new maximum temperature. Repeat this until desired temperature is reached.

Maintenance Instructions

[A] CASTERS

Some casters are equipped with Zerk grease fittings so that they may be easily lubricated with a grease gun. Recommended lubrication is at least once every six months. Lubrication will be required more frequently if carts are cleaned with a hot water or steam cleaning system. Casters with special bearings are recommended for frequent cart wash or steam cleaning situations.

[B] LATCHES

Check frequently to insure that all door latches are secure. Latches may become "sticky" due to residue buildup from daily use and cleaning. Lubricate latches regularly with WD-40, silicone spray, graphite or other commercial lubricants for stainless steel products. Do not use oil.

[C] PERIMETER BUMPERS

If applicable, vinyl which has been dislodged from the channel due to severe bumping or scraping can be pried back into place with a common screwdriver.

Replacement Parts

TH15 TOP MOUNT HEATER: PH188, 1820, 1840 WITH FLUSH MOUNT DOOR

Part Number	Description	Part Number	Description
16500-8273	Heater Cover	18600-0046	HI-Limit (300° Auto Reset)
16500-8276	Control Panel	18616-0015	Dial Thermometer
18314-0070	Water Pan	18602-0055	Lighted On/Off Switch 120 Volt
18614-0320	Fan Motor - Dual Volt	18602-0056	Lighted On/Off Switch 220 Volt
18614-0321	Fan Blade	18601-0070	Indicating Light 120 Volt
18614-0306	Fan Blade Housing	18601-0080	Indicating Light 220 Volt
18612-0096	Heat Element 120 Volt/1500 Watt	18605-0010	Power Cord w/Plug 120 Volt
18612-0110	Heat Element 220 Volt/1500 Watt	18605-0015	Power Cord w/Plug 220 Volt
18600-0010	Thermostat	16500-8266	Cord Wrap
18608-0010	Thermostat Knob		

Wiring Diagram

TOP MOUNT HEATERS
FOR FLUSH MOUNT DOORS 11000-1262 120 VOLT

TOP MOUNT HEATERS
WITH FLUSH DOOR MOUNT 11000-1312 220 VOLT

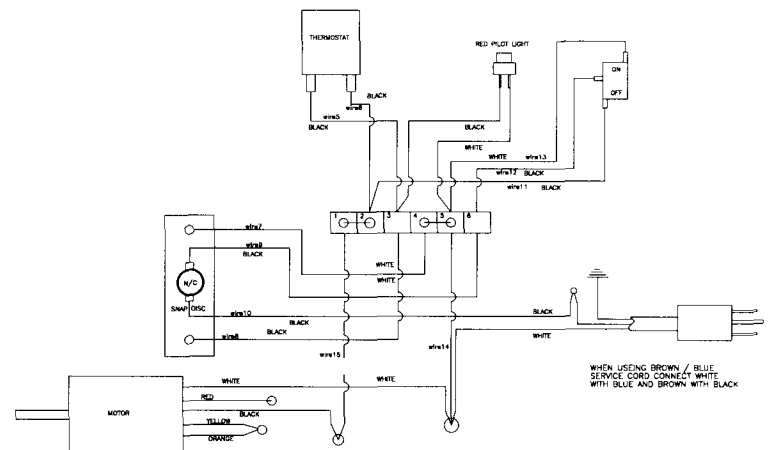
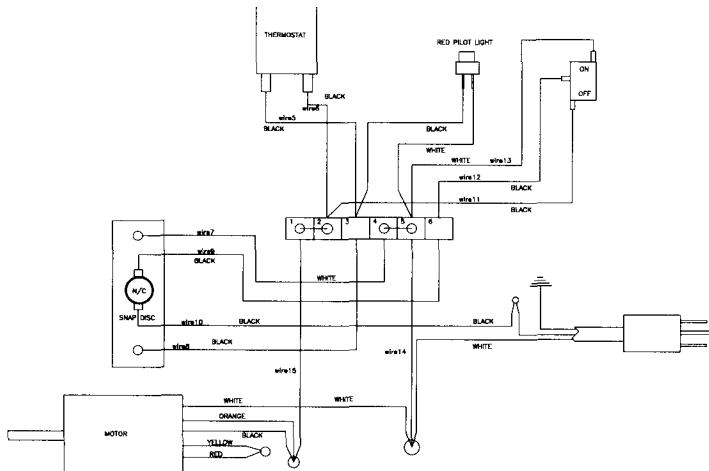

Replacement Parts

THIS TOP MOUNT HEATER: PH1835 WITH NON-FLUSH DOOR

Part Number	Description	Part Number	Description
16501-6685	Heater Cover	18608-0010	Thermostat Knob
16501-4832	Control Panel	18616-0094	Transformer
18312-0153	Vinyl Control Panel Overlay	18616-0096	Digital Thermometer
18314-0070	Water Pan	29037-9000	Red Thermometer Cover
18614-0320	Fan Motor - Dual Volt	18616-0097	Probe Assembly
18614-0321	Fan Blade	18601-1150	Red Pilot Light
18614-0306	Fan Blade Housing	18602-0055	Lighted On/Off Switch 120 Volt
18614-0314	Cooling Fan 120 Volt	18602-0056	Lighted On/Off Switch 220 Volt
18614-0315	Cooling Fan 220 Volt	18605-0010	Power Cord w/Plug 120 Volt
18600-0042	Cooling Fan Sensor (Snap Disc)	18605-0015	Power Cord w/Plug 220 Volt
18600-0046	HI-Limit (300° Auto Reset)	16500-8266	Cord Wrap
18612-0096	Heat Element 120 Volt/1 500 Watt	29034-0028	High Temp Heater Gasket
18612-0111	Heat Element 208 Volt/1 500 Watt		

* Contact factory with your model and serial number for

Wiring Diagram

TOP MOUNT HEATERS
FOR NON-FLUSH DOOR MOUNT 11000-1258 120 VOLT

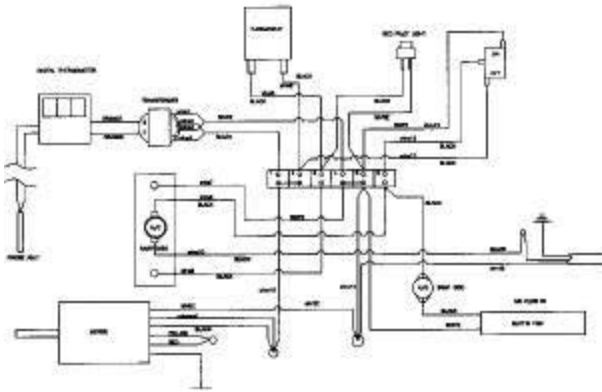

TOP MOUNT HEATERS
FOR NON-FLUSH DOOR MOUNT 11000-1259 220 VOLT

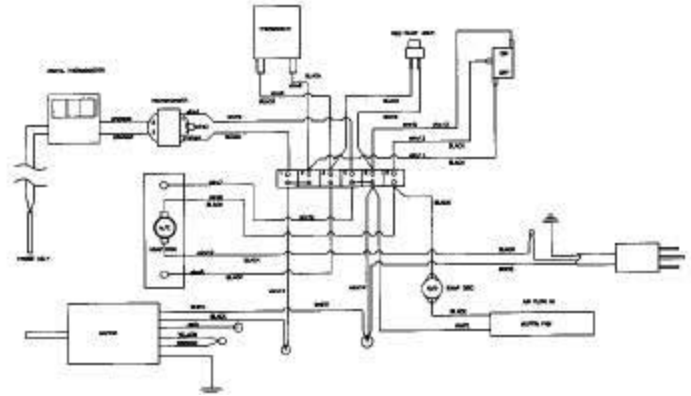

Carter-Hoffmann Corporation Warranty:
Carter-Hoffmann Corporation ("CARTER-HOFFMANN") warrants to the initial purchaser of its standard Carter line Products that CARTER-HOFFMANN will, at its option, repair or replace, during the warranty period set forth below, any part of such products made necessary due to a defect in material or workmanship which is present when the product leaves its factory and which manifests itself during the warranty period under normal use and service.

This warranty applies only to original equipment owned and possessed by the initial purchaser and the warranty period begins on the date of original shipment from the CARTER-HOFFMANN factory and extends as follows: **to electrical and refrigeration components for one year; to electrical and refrigeration labor for 120 days; to refrigeration compressor unit for 1 year** (limited to replacement of the unit only—not to include labor for removal, repair or replacement), **and to all other component parts and labor for 12 months.**

Repair or replacements under this warranty will be performed, unless otherwise authorized in writing by CARTER-HOFFMANN, at its factory. All parts or components to be repaired or replaced under this warranty are to be shipped prepaid to CARTER-HOFFMANN, with reimbursement credit for such part or component to be given if found by CARTER-HOFFMANN to be defective.

CARTER-HOFFMANN neither makes nor assumes and does not authorize any other person to make or assume any obligation or liability in connection with its products other than that covered in this warranty. This warranty applies only within the continental United States and Canada. In Alaska and Hawaii, this warranty applies only to and is limited to the supply of replacement parts.

Warranty Exclusions And Limitations:

Any implied warranty of merchantability or fitness for a particular purpose is hereby specifically disclaimed by Carter-Hoffmann Corporation. There are no warranties, expressed or implied, which extend beyond the description on the face hereof.

This warranty does not cover and CARTER-HOFFMANN shall not under any circumstances be liable for any incidental, consequential or other damages (such as injury to persons or property, loss of time, inconvenience, loss of use, loss of business or profits, or other matters not specifically covered) arising in connection with the use of, inability to use, or failure of these products.

Specifications subject to change through product improvement and innovation. Printed in U.S.A.



Since 1947, Foodservice Equipment That Delivers!
1551 McCormick Avenue,
Mundelein, Illinois 60060
Tel. 1-800-323-9793
Fax No. (847) 367-8981
NOVEMBER 1997
18400-3013C
SN/97P1342