

# Parts Manual

---

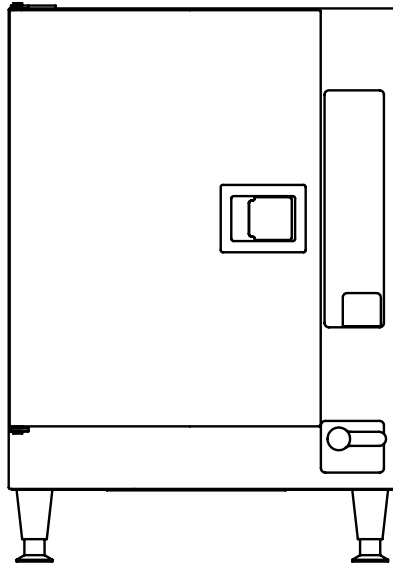

PATENT PENDING

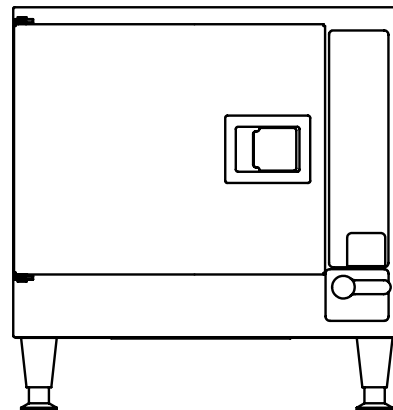

---

## Energy Star SteamChef Models 22CET3.1

---

1333 East 179<sup>th</sup> Street  
Cleveland, Ohio 44110

Phone: (216) 481 - 4900  
1-800-338-2204

Fax: (216) 481 - 3782  
[www.clevelandrange.com](http://www.clevelandrange.com)



Cleveland

Part No. 22CET3.1Parts

50	1	1123600100	TUBE, NEOPRENE, 5/16"ID x 1'LG	106	3	14692	NUT, HEX, 10-24, ELASTIC LOCK, ZINC PLTD, FASTENER
49	1	110713	SOCKET, 1/4" DRIVE, 9/16" 12 POINT	105	4	106699	NUT, SLIPON, #10-24, TIN, C17205-1024
48	1	110745	NUT, HEX, 8-32 SMALL PATTERN, 1/4", SST	104	1	05253	ELBOW, STREET, 90°, 1/2 NPT, BRASS
47	1	101336	WASHER, FLAT, #8, SST	103	6	111484	SCREW, 6-32 X 3/8", PHILLIPS HEAD
46	1	102187	RING, RETAINING, .688 CRESCENT, J STEAMER	102	1	110805	INSULATION, BOTTOM PAN, STEAMCHEF
45	1	112243	BUSHING, SUPPORT, GEMINI	101	1	109136	INSULATION, BOTTOM PAN, STEAMCUB, H.L.
44	1	112319	LABEL, POWER CONTROL, STEAMCHEF 3.1/6.1 HL	100	1	110680	INSULATION, FIBERGLASS, BOTTOM REAR, STEAMCHEF 3
43	1	112320	SHAFT, HANDLE TO VALVE, STEAMCHEF 3.1/6.1	99	1	110679	INSULATION, FIBERGLASS, BOTTOM FRONT, STEAMCHEF 3
42	1	300331	PANEL ASSY, MECH. TIMER, CHEF HL	98	3	110677	INSULATION, BOTTOM, STRIPS, STEAMCHEF 3
41	1	112001	WELDMENT, BASE PAN, STEAMCHEF 3.1/6.1, HL	97	24	112481	NUT, HEX, 1/4-20 X 7/16 BR
40	3	19555	SPACER, 1/4" I.D. X 1/2 O.D.	96	24	112480	WASHER, BELLEVILLE, 1/4", 0.258 ID X 0.813 OD X 0.062 THK, TYP3 301 SST
39	1	300695	HV. PANEL, ASSY, STEAMCHEF, 6KV, 9KW & 13.5KW, 240/480V, HL ENERGY STAR	95	4	110496	NUT, SLIPON, 10-24, PNL .025
38	1	300677	SWITCH, SNAP ACTING, 193 DEG. F, THERMAL CLOSE	94	1	1058501900	HOSE, 1/4" ID x 19", SILICON REINFORCED
37	3	109152	SWITCH SNAP	93	1	1058501700	HOSE, NYLON REINFORCED, 1/4" ID, 17" LG
36	12	109134	CHANNEL, HEATER MOUNTING STEAMCUB	92	1	110229	BUSHING, SNAP-IN FOR 2" DIA HOLE
35	3	300186	HEATER, CAST, 208V, 3000W	91	1	102581	BUSHING, SNAP-IN FOR 1 1/2 DIA HOLE
34	1	112740	ASSEMBLY, WATER SUPPLY, CHEF 3, 6	90	6	14672	NUT, HEX, 10-32, ELASTIC LOCK, ZINC PLTD
33	2	41423	RACK ASSEMBLY, PAN 20"	89	2	101655	WASHER, FLAT, #10, SST
32	6	101953	CLIP, INSULATION RETAINER, 1-1/2, .105 HOLE, GALV.	88	7	104080	SCREW, TR, PHH, 8x1/2, TYPE B, SST
31	1	112036	SHEETING, TOP/BACK, STEAMCHEF 3.1, HL	87	10	101231	SCREW, 10-24 X 0.500 SST, PHILLIPS TRUSS HEAD
30	1	110694	SPACER, CONTROL LEVER STEAMCHEF 3	86	5	14665	NUT, HEX, 1/4-20 LOCK, SST (NYLON INSERT)
29	1	110652	LEVER, CONTROL	85	2	108734	NUT, "U" TYPE (EXTRUDED) #10-24 UNC-2B THREAD
28	1	111272	SEAL, 1/4" ID X 3/4" OD X 1/4" THRU	84	4	111798	NUT, RETAINER, 1/2-13NC, 2B
27	1	110683	MOTOR, BLOWER STEAMCHEF 3	83	1	110675	INSULATION, BODY WRAP, ST
26	4	101873	NUT, HEX 1/4-20 THIN LOCK, ZINC PLTD, STEEL	82	A/R	111299	GREASE, FOOD GRADE
25	1	1118682	GUARD, BACKPLATE, FAN, STEAMCHEF 3.1	81	2	111780	WASHER, RETAINER, INSULATION
24	1	1118681	GUARD, FAN, STEAMCHEF	80	1	108617	THERMOSTAT, 205 DEG. F.
23	4	111290	SCREW, SHOULDER, 1/4-20 W/FLAT, FAN GUARD AND MOTOR SUPPORT, 316L SST	79	1	300255	BREAKER, CIRCUIT 1.5 AMP
22	1	112690	ASSY, PLATE, MOTOR MOUNTING, CHEF 3.1/6.1, HLHR	78	1	108848	BRACKET, CIRCUIT BREAKER SHIELD STEAMCRAFT 3.1 & 5.1
21	1	112235	ASSEMBLY, DRAIN/POWER SWITCH, H.L., STEAMCHEF 3.1/6.1	77	1	108031	CAP, HOSE NUT 3/4" HOSE THD.
20	1	112387	INSULATION, REAR, CHEF 3.1, HL ENERGY STAR UNIT	76	1	108034	WASHER 3/4 GHT HOSE
19	3	104062	RING, EXT, RETAINING, SST	75	1	1060930850	HOSE, SILICONE 3/4" ID X 8.500 LG.
18	2	104077	PIN, HINGE	74	1	106157	FITTING, BULKHEAD, 1/2NPT FOR 1 1/8" ID OPENING
17	1	108171	WHEEL, BLOWER BMW-334	73	1	111354	FTG. BARB, 3/4H x 1/2 MPT, 90 DEG, BRASS
16	4	19170	SCREW, HEX HD, 1/4-20x5/8, SST	72	1	112244	BUSHING, INSERT
15	7	23105	WASHER, LOCK, 1/4" KATLINK STYLE, SST	69	1	1123170175	HOSE, 1.250" ID X 1.500 OD X 1.750 LG., NEOPRENE
14	13	23116	WASHER, FLAT, .281 ID x .625 OD x .065 THK, SST	68	1	1060930275	HOSE, SILICONE 3/4" ID X 2.750 LG.
13	2	14649	NUT, HEX, 1/2-13, ZINC PLTD	67	1	107312	CLAMP, HOSE, 1 1/8" OD, METAL TENSION BAND
12	2	23149	WASHER, NYLON, TYPE 616	66	1	08511000	HOSE, WHITE EPDM, 3/4" ID X 10.000" LG
11	8	101305	PIN, RACK SUPPORT, S/S, 316L	65	1	112260	SHAFT COLLAR
10	2	14695	NUT, DOOR CATCH MOUNTING	64	4	1110021	ASSEMBLY, FOOT, STEAMCHEF
9	12	14618	NUT, HEX, 1/4-20, STAINLESS STEEL	63	2	103966	SHEETING, SIDE, STEAMCRAFT 3.1
8	1	112684	WELDMENT, CONDENSER BOX, HL, X2	62	1	03204	CLAMP, HOSE, WORM DRIVE 0.812 X 1.50 DIA
7	1	3003231	ASSEMBLY, PROBE, DUAL LEVEL, HL	57	4	03207	HOSE, CLAMP, LINED, WORM DRIVE, MAX OD 1.125
6	1	104046	CATCH, DOOR	56	1	106288	SWITCH, THERMOSTAT, 140 DEG
5	1	111029	ASSEMBLY, COLLECTOR PLATE, H.L., STEAMCHEF	55	2	06241	FTG. HOSE BARB, 3/4Hx1/2MPT, BR.
4	1	104101	DOOR ASSY, INNER, CONV, STM.	54	2	102018	CLAMP, HOSE, WORM DRIVE 1.5" - 2.0"
3	1	110640	DOOR, OUTER ASSEMBLY, HL STEAMCHEF 3 W/LOGO	53	1	112737	COVER, DOOR, FAN ACCESS, CHEF 3, 6
2	2	104035	HINGE, DOOR	52	1	300702	PANEL, COMPONENT ASSY, CHEF, HL ENERGY STAR
1	1	112033	WELDMENT, CAVITY, STEAMCHEF 3.1, HL	51	5	106526	CLAMP, HOSE, WORM DRIVE, 3/8 TO 5/8x5/16W, SST
ITEM	QTY	PART NO.	DESCRIPTION	ITEM	QTY	PART NO.	DESCRIPTION

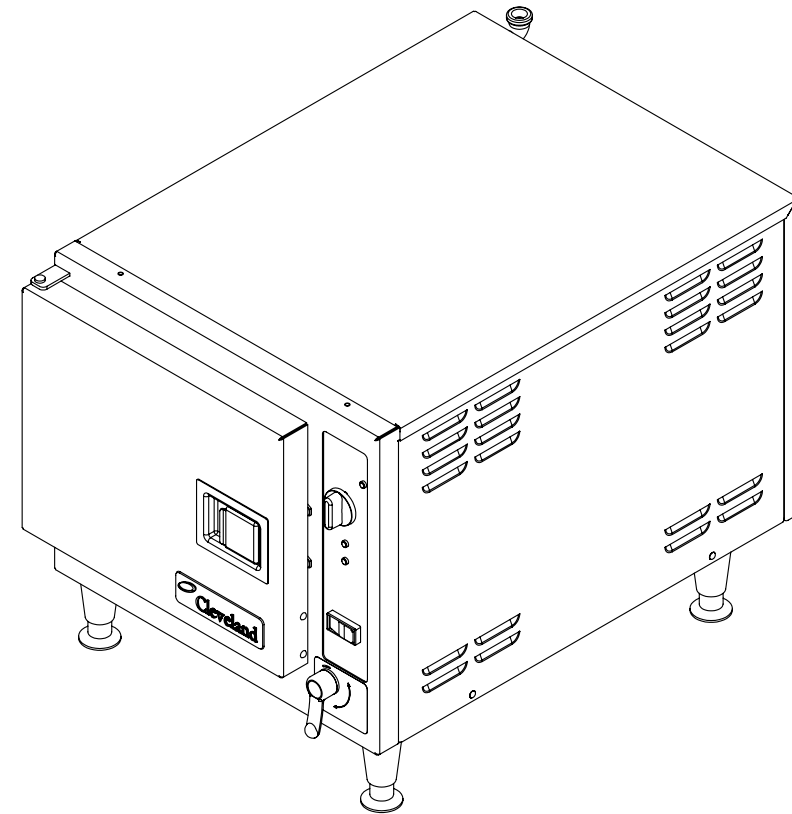

**OPTIONS LIST:**

**CONTROL PANEL ASSEMBLY**

- 300331 PANEL ASSY, MECH. TIMER, CHEF HL
- 300348 PANEL, CTRL, ASSY, ETC. HL, W/60 MIN MANUAL TIMER, CHEF
- 300347 PANEL, CTRL, ASSY, ON-OFF, HL, CHEF

**HEATER, CAST, 3000 W STEAMCUB, STEAMCHEF**

- 3001862 HEATER, 480V, 3000W, CAST
- 3001861 HEATER, 240V, 3000W, CAST
- 300186 HEATER, 208V, 3000W, CAST

SEE OPTIONS LIST

SEE OPTIONS LIST

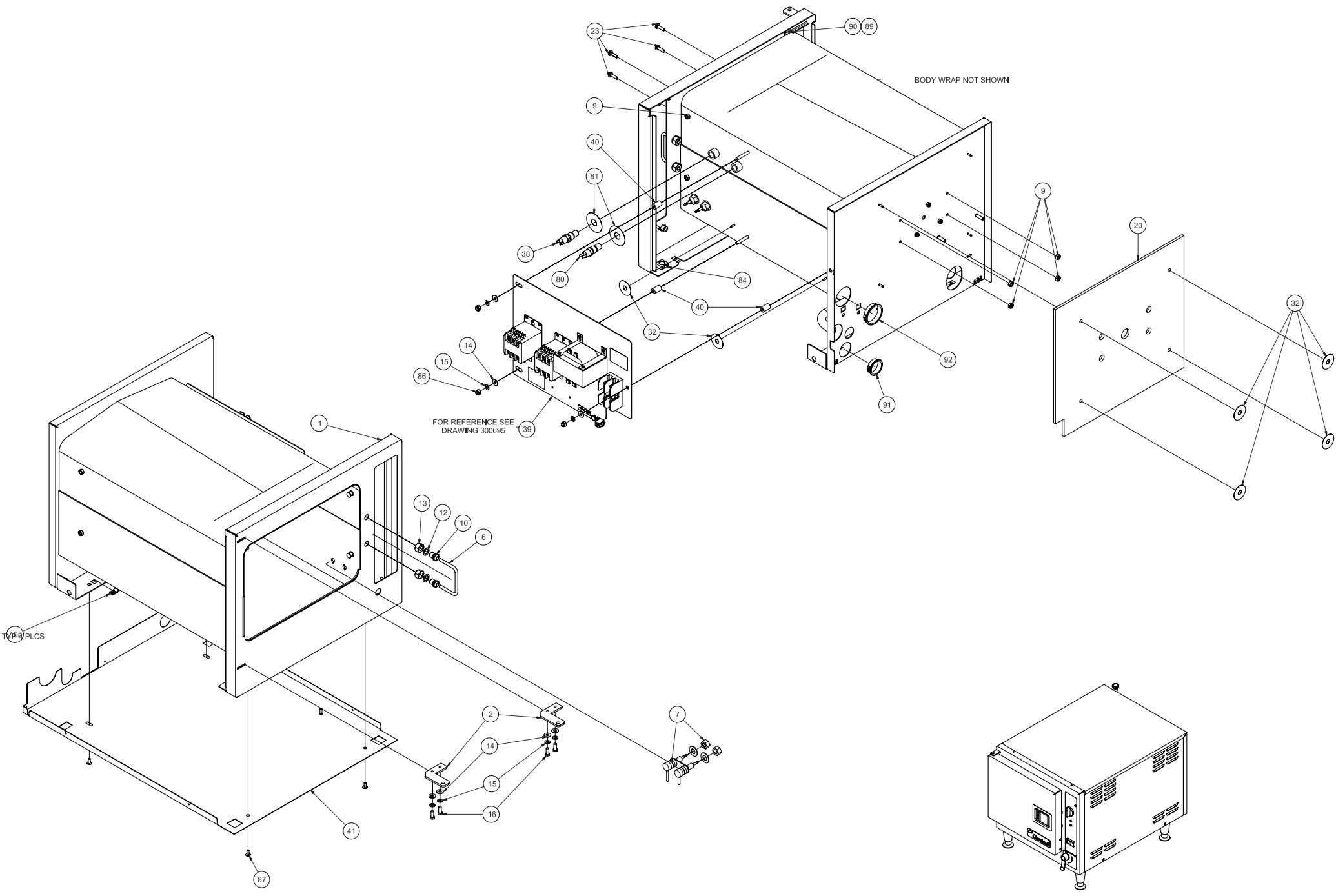

TV109 PLCS

FOR REFERENCE SEE  
DRAWING 300695

BODY WRAP NOT SHOWN

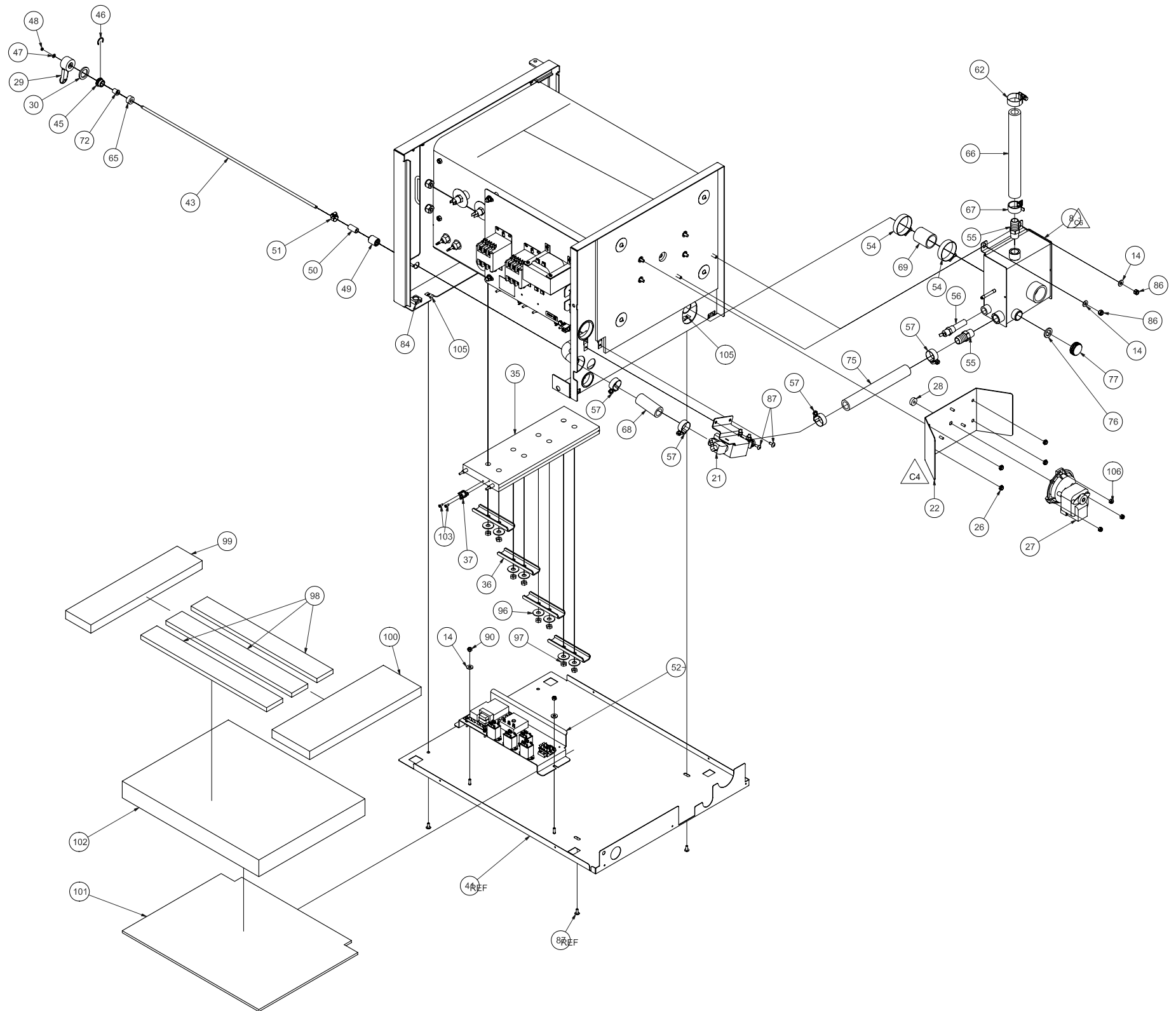

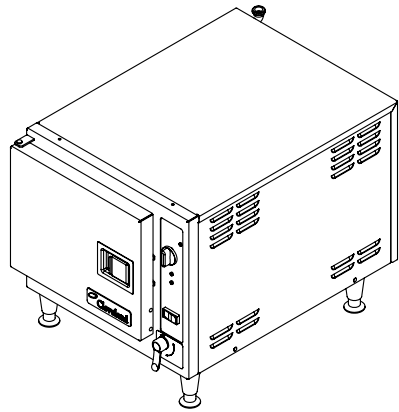

FOR REFERENCE  
300331 FOR MECHANICAL TIMER  
300348 FOR ELECTRONIC TIMER  
300347 FOR ON/OFF

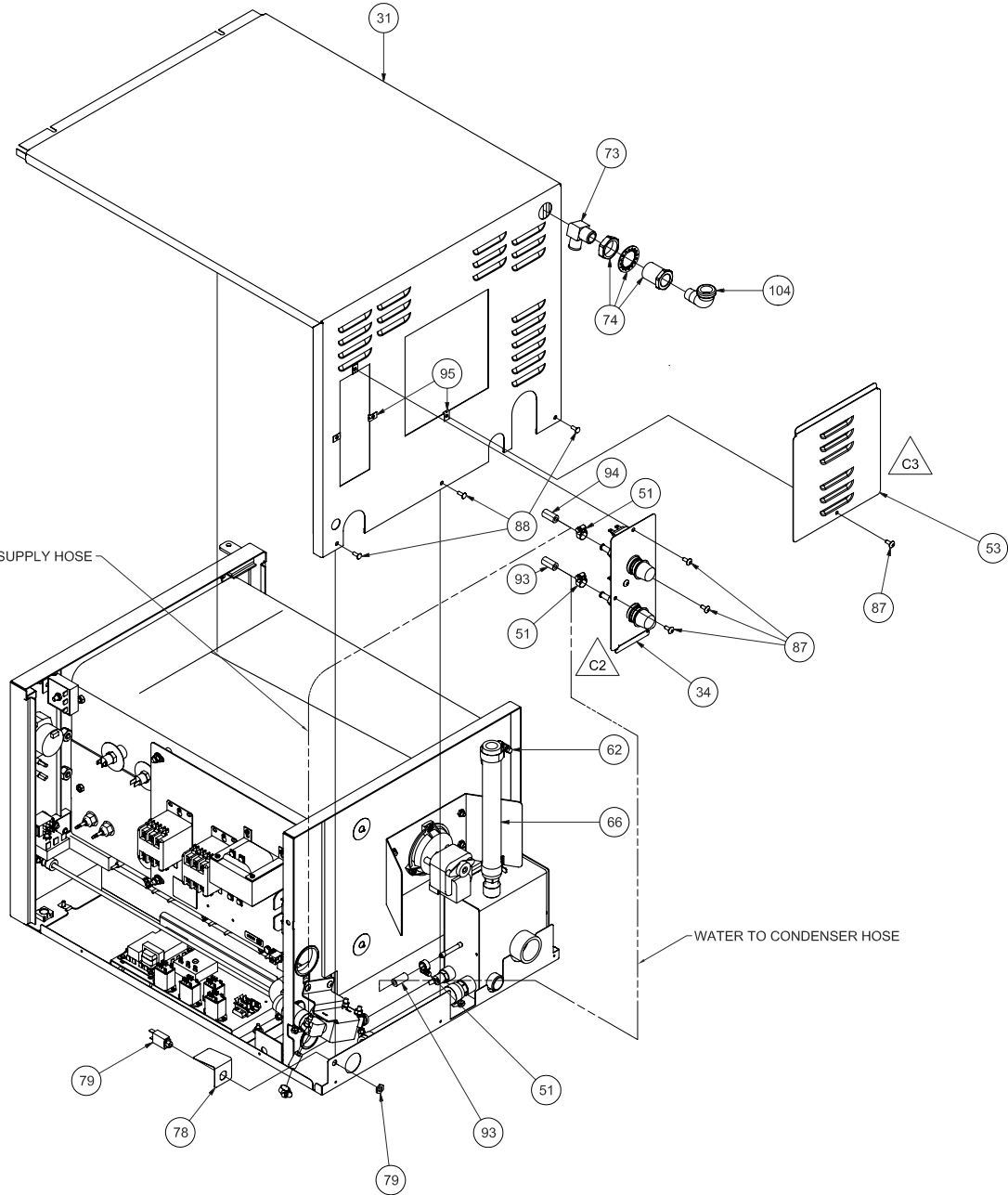
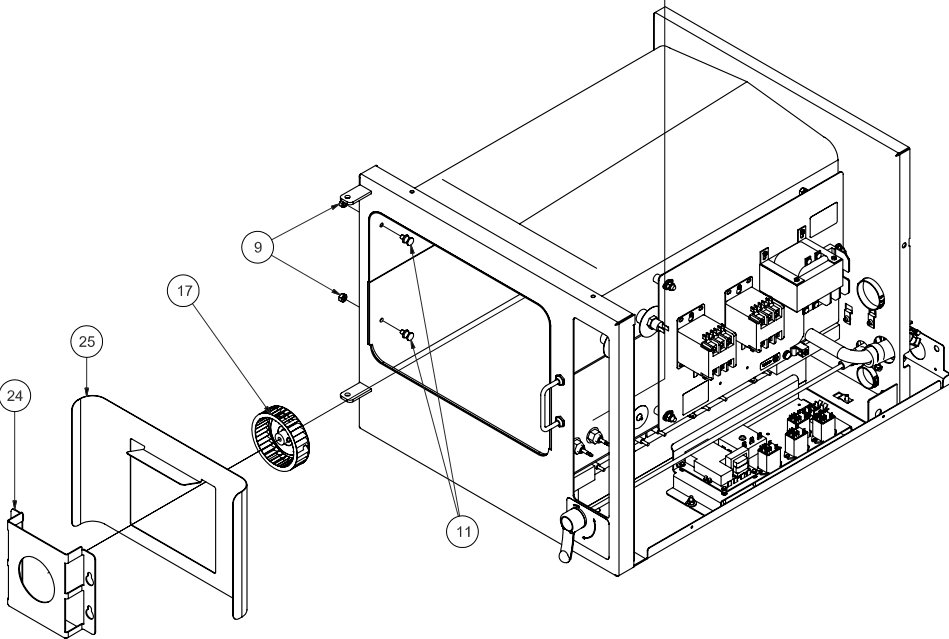
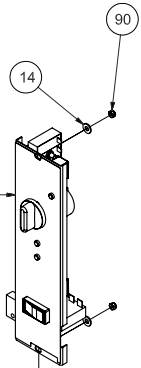

WATER SUPPLY HOSE

WATER TO CONDENSER HOSE

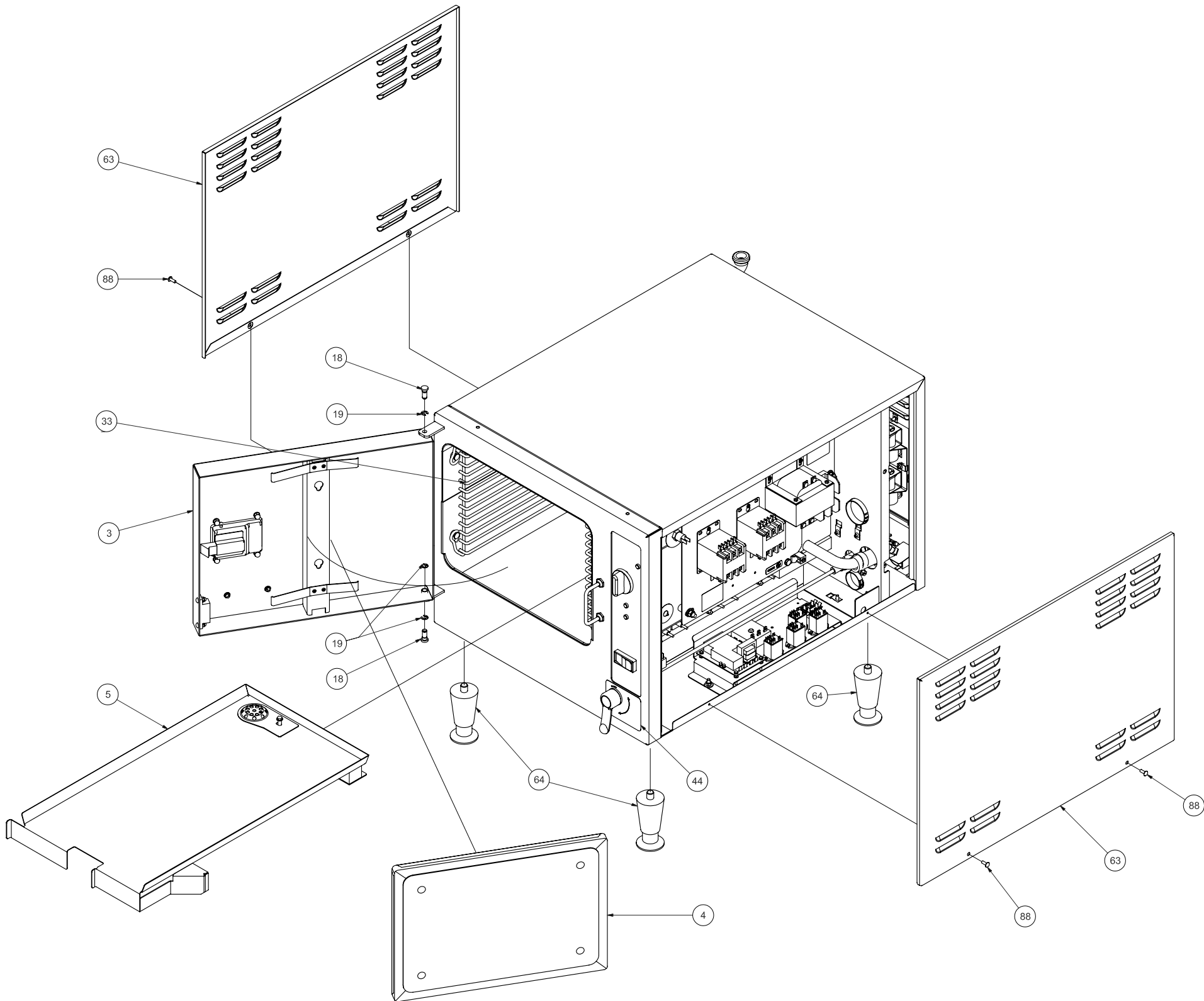

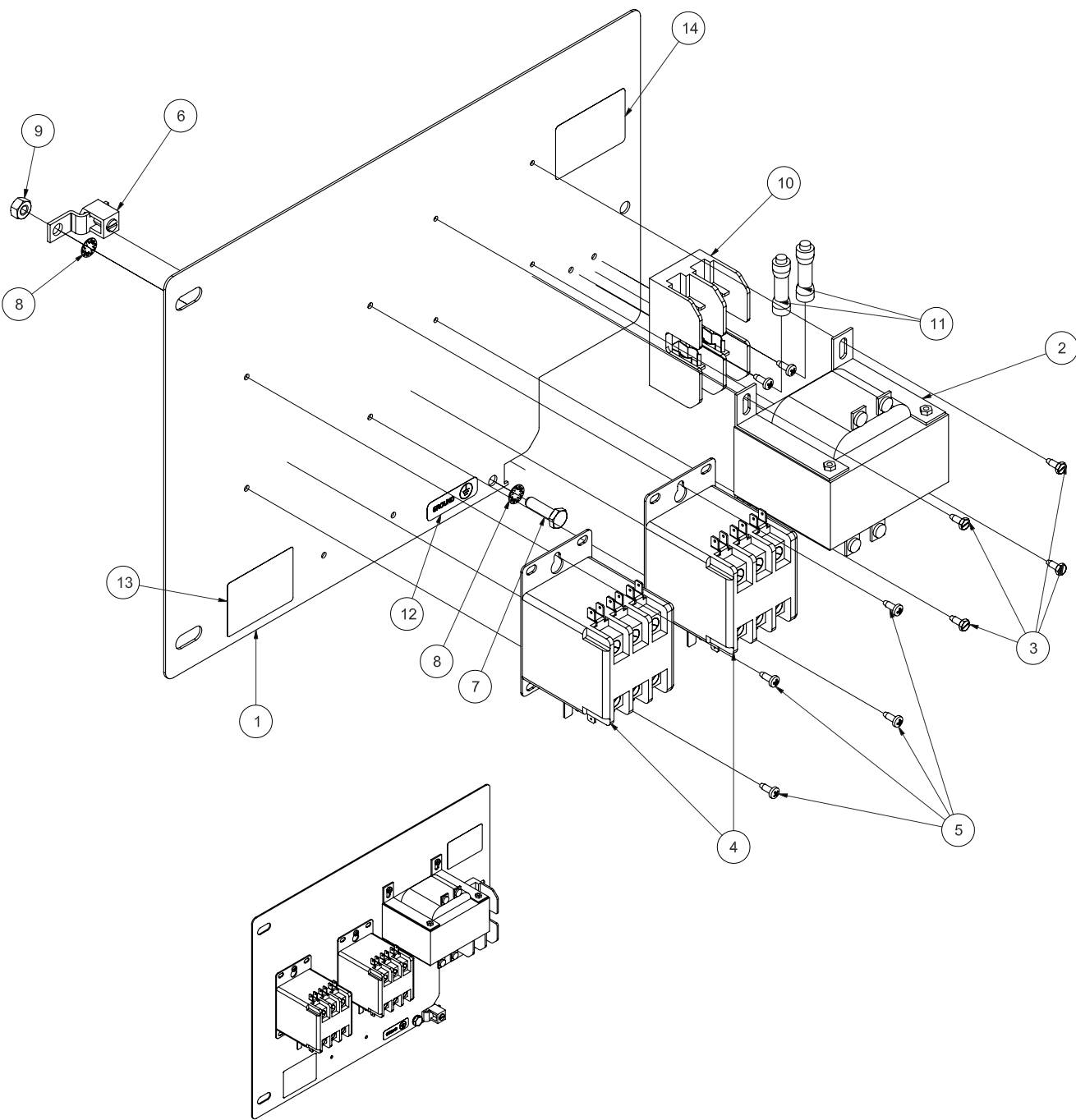

NOT SHOWN  
 NOT SHOWN  
 NOT SHOWN

17	1	20322	TERMINAL, SLIP-ON, 0.032 X 0.250, 16-14 GA
16	1	300341	HARNESS, FUSE BLOCK, HIGH-VOLTAGE
15	1	300238	WIRE, ASSY., TRANS. JUMPER
14	1	109986	LABEL, FUSE SIZE, 5 AMPS
13	1	104349	LABEL, WARNING FIELD CONVERSION
12	1	14897	LABEL, GROUND
11	2	109380	FUSE, 3.5 AMP
10	1	109374	BLOCK, FUSE, 2 POLE, 30 AMP
9	1	14618	NUT, HEX, 1/4-20, STAINLESS STEEL
8	2	23137	WASHER, LOCK, INTERNAL TOOTH 1/4" SST
7	1	19288	SCREW, 1/4-20 X 3/4, HEX, HD, ZINC PLATED
6	1	12331	LUG, GROUND, SOLDERLESS
5	6	106126	SCREW, 8-32 X 1/2, TORX/SLT.PAN HD
4	2	03509	CONTACTOR, 50 AMP, 104-120V
3	4	106754	SCREW, 8-32 X 3/8, HEX/SLOT-WASHER HD.
2	1	300254	TRANSFORMER, 200VA, 240V/480V PRIMARY
1	1	112612	PANEL, COMPONENT, STEAMCHEF
ITEM	QTY	PART NO.	DESCRIPTION

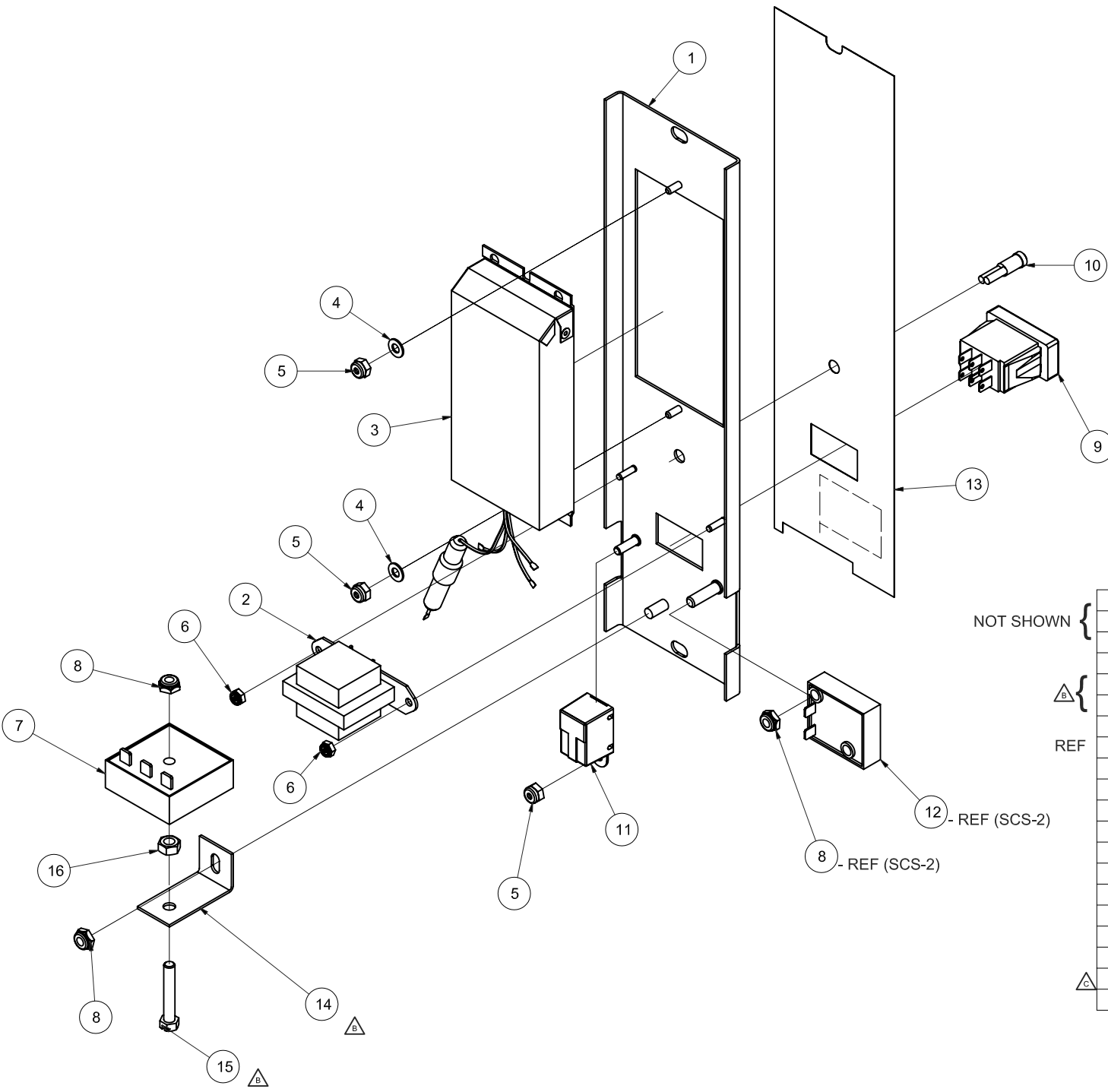

ITEM	QTY	PART NO.	DESCRIPTION
19	1	20351	TERMINAL, SLIP-ON, FULL INSUL, .032X .250 TAB
18	1	300346	HARNESS, WIRE, ELEC CONTROL PANEL
17	1	109153	LABEL, SLIP-IN MODEL NO./SERIAL NO.
16	1	14617	NUT, HEX 1/4-20 STEEL OXIDE FINISH
15	1	19175	SCREW, HEX HD, NON-SLTD
14	1	105955	BRACKET, DUAL TIMER MOUNTING
13	1	1106681	LABEL, NCC TIMER, STEAMCHEF
12	-	108880	SWITCH, DOOR STEAM CUTOFF
11	1	41350	BUZZER, ASSY, CONTINUOUS DUTY, 120VAC, 50-60HZ
10	1	12159	LIGHT, INDICATOR, NEON, RED, 7" MIN LEAD LENGTH
9	1	104224	SWITCH, ROCKER DPDT, MATTE
8	2	101873	NUT, HEX 1/4-20 THIN LOCK, ZINC PLTD, STEEL
7	1	300150	TIMER, SOLID STATE, 60 MINUTE FIXED DELAY
6	2	104223	NUT, HEX 6-32 ELASTIC LOCK
5	3	14692	NUT, HEX, 10-24, ELASTIC LOCK, ZINC PLTD, FASTENER
4	2	101655	WASHER, FLAT, #10, SST
3	1	104389	TIMER ASSEMBLY NCC
2	1	104390	TRANSFORMER ASSEMBLY
1	1	1106641	PANEL, CONTROL, WELDMENT, ETC TIMER, STEAMCHEF, HL

NOT SHOWN {

△B {

REF

△C

12 - REF (SCS-2)

8 - REF (SCS-2)



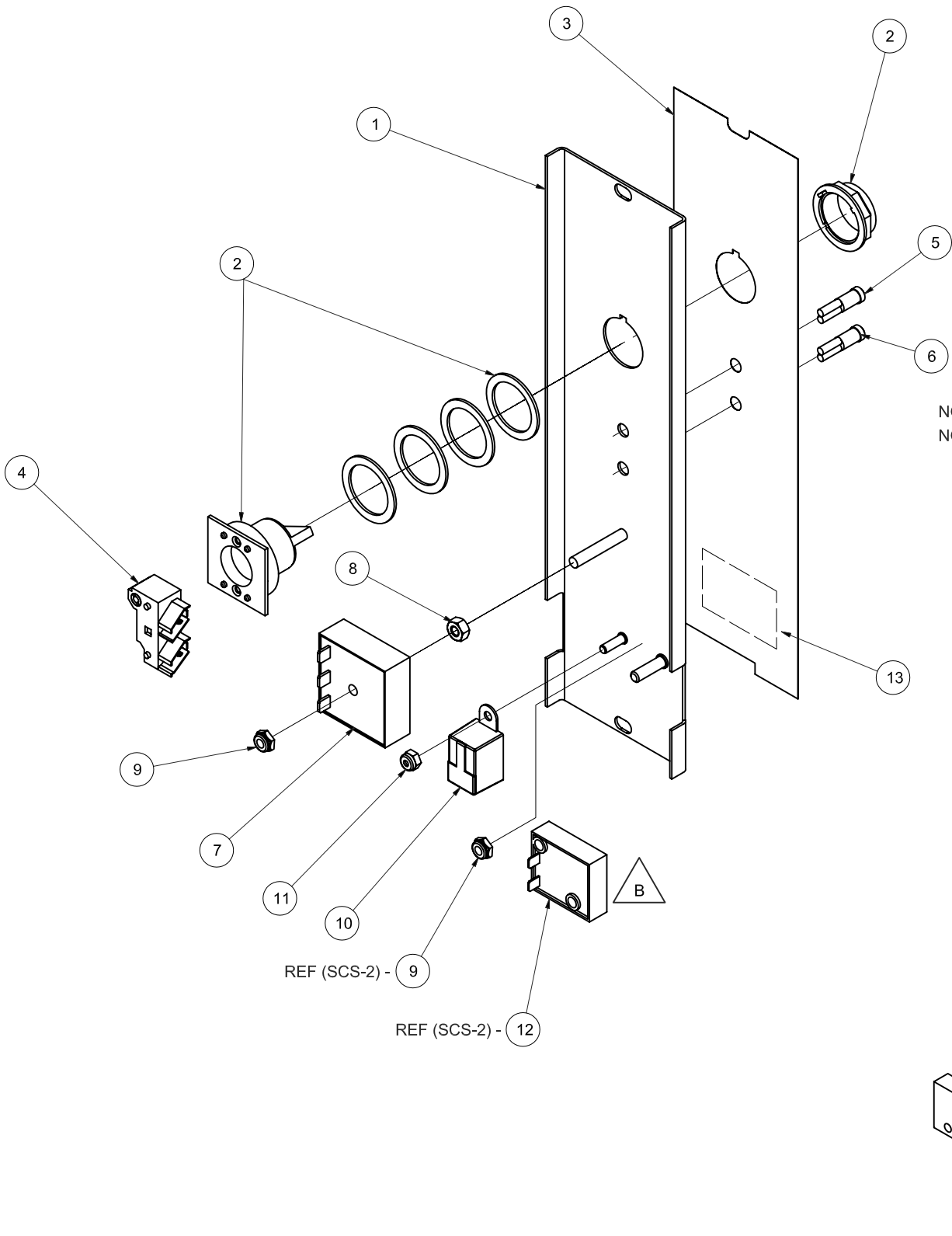

NOT SHOWN  
NOT SHOWN

ITEM	QTY	PART NO.	DESCRIPTION
15	4	20351	TERMINAL SLIPON FULL-INSUL
14	1	300345	HARNES, WIRE CTRL PANEL, ON-OFF
13	1	109153	LABEL, SLIP-IN, MODEL NO/SERIAL NO.
REF	-	108880	SWITCH, DOOR STEAM CUTOFF
11	1	14692	NUT, HEX, 10-24, ELASTIC LOCK, ZINC PLTD, FASTENER
10	1	41350	BUZZER, ASSY, CONTINUOUS DUTY, 120VAC, 50-60HZ
9	1	101873	NUT, HEX 1/4-20 THIN LOCK, ZINC PLTD, STEEL
8	1	14618	NUT, HEX, 1/4-20, STAINLESS STEEL
7	1	300150	TIMER, SOLID STATE, 60 MINUTE FIXED DELAY
6	1	12159	LIGHT, INDICATOR, NEON, RED, 7" MIN LEAD LENGTH
5	1	109494	LIGHT, GREEN INDICATOR, NEON, 120V
4	1	102533	BLOCK, CONTACT
3	1	110669	LABEL, CTRL, ON/OFF, STEAMCHEF
2	1	102534	SWITCH, SELECTOR
1	1	110666	PANEL, CONTROL, WELDMENT, ON/OFF, STEAMCHEF, HL

ITEM QTY PART NO. DESCRIPTION

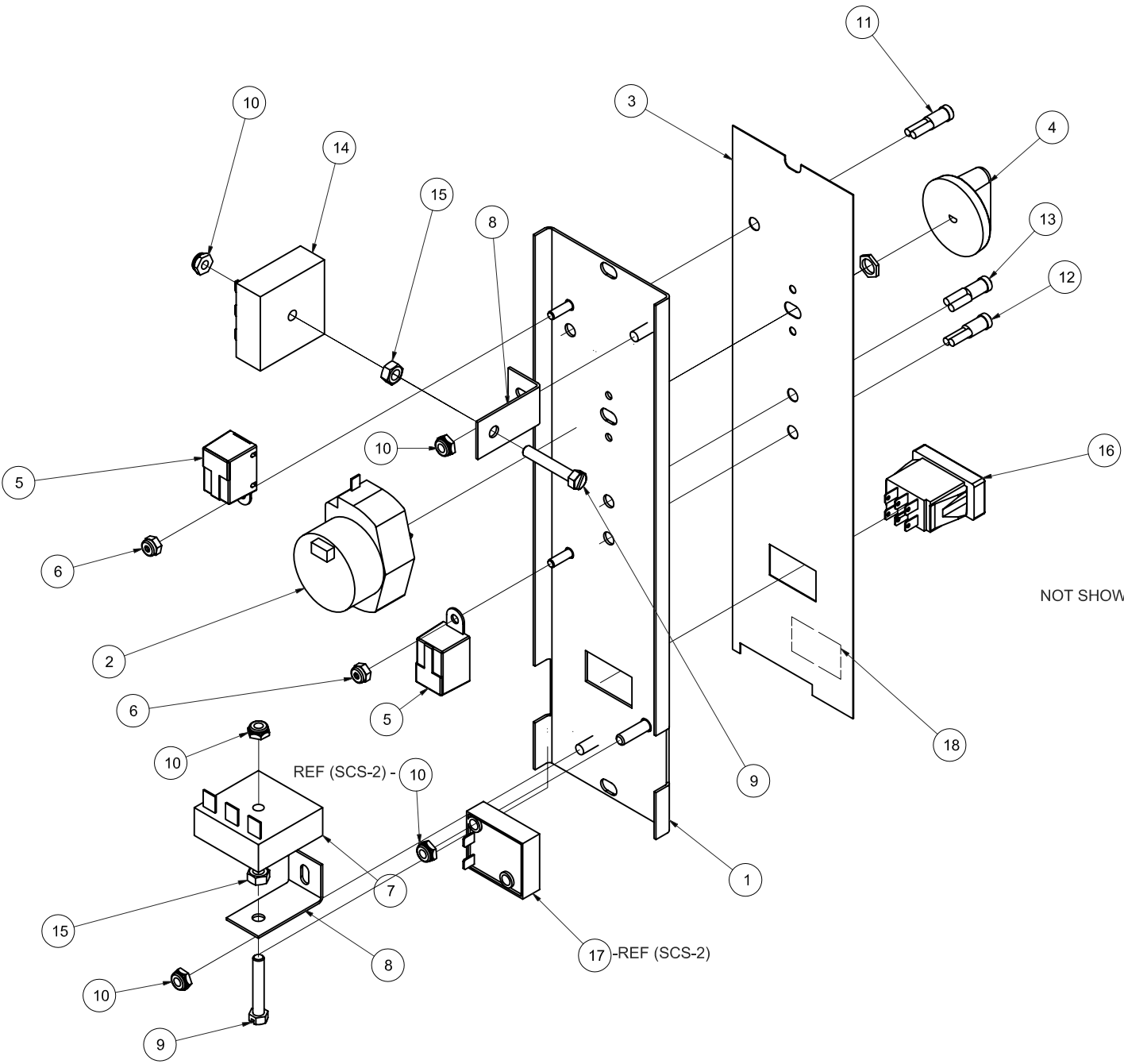

NOT SHOWN {  
REF

	20	8	20351	TERMINAL, SLIPON FULL-INSUL.
	19	1	300333	HARNESS, MECH TIMER PANEL
	18	1	109153	LABEL, SLIP-IN, MODEL NO/SERIAL NO.
REF	17	-	108880	SWITCH, DOOR STEAM CUTOFF
	16	1	104224	SWITCH, ROCKER DPDT, MATTE
	15	2	14617	NUT, HEX 1/4-20 STEEL OXIDE FINISH
	14	1	300150	TIMER, SOLID STATE, 60 MINUTE FIXED DELAY
	13	1	109494	LIGHT, GREEN INDICATOR, NEON, 120V
	12	1	12159	LIGHT, INDICATOR, NEON, RED, 7" MIN LEAD LENGTH
	11	1	109602	LIGHT, AMBER INDICATOR, NEON, 120V, 7" MIN LEAD LENGTH
	10	4	101873	NUT, HEX 1/4-20 THIN LOCK, ZINC PLTD, STEEL
	9	2	19175	SCREW, HEX HD, NON-SLTD
	8	2	105955	BRACKET, DUAL TIMER MOUNTING
	7	1	20477	TIMER, SOLID STATE, 3 SEC DELAY ON BREAK
	6	2	14692	NUT, HEX, 10-24, ELASTIC LOCK, ZINC PLTD, FASTENER
	5	2	41350	BUZZER, ASSY, CONTINUOUS DUTY, 120VAC, 50-60HZ
	4	1	110661	KNOB, EAGLE TIMER
	3	1	110667	LABEL, CTRL, MECH., STMCHEF
	2	1	110198	TIMER, MOTOR DRIVEN, 60 MIN. 115V 60HZ
	1	1	111451	PANEL, CONTROL, WELDMENT, MECH. TIMER, STEAMCHEF, HL
ITEM	QTY	PART NO.	DESCRIPTION	

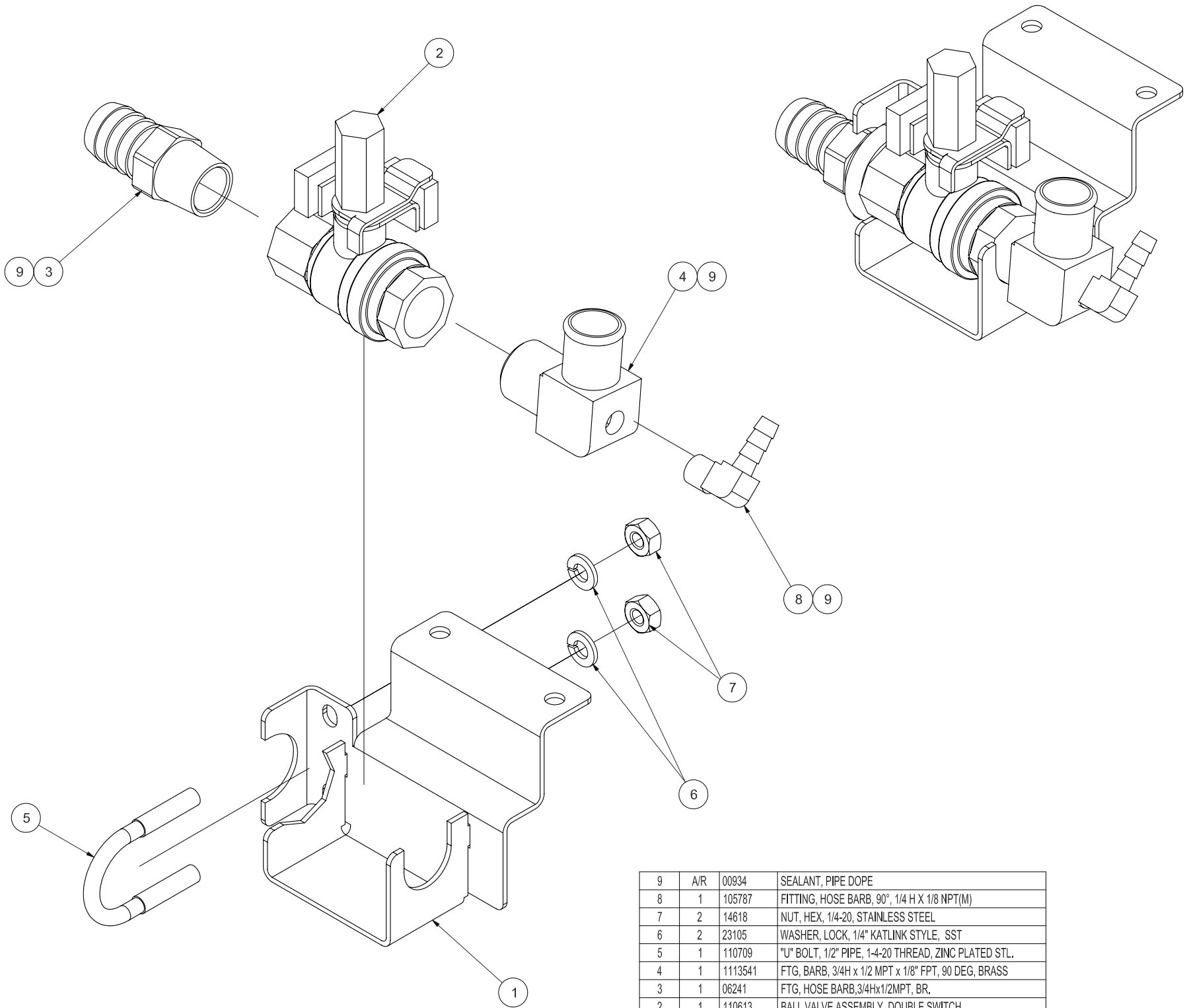

9	A/R	00934	SEALANT, PIPE DOPE
8	1	105787	FITTING, HOSE BARB, 90°, 1/4 H X 1/8 NPT(M)
7	2	14618	NUT, HEX, 1/4-20, STAINLESS STEEL
6	2	23105	WASHER, LOCK, 1/4" KATLINK STYLE, SST
5	1	110709	"U" BOLT, 1/2" PIPE, 1-4-20 THREAD, ZINC PLATED STL.
4	1	1113541	FTG, BARB, 3/4H x 1/2 MPT x 1/8" FPT, 90 DEG, BRASS
3	1	06241	FTG, HOSE BARB, 3/4Hx1/2MPT, BR.
2	1	110613	BALL VALVE ASSEMBLY, DOUBLE SWITCH
1	1	112257	BRACKET, VALVE, STEAMCHEF 3.1/6.1, HL
ITEM	QTY	PART NO.	DESCRIPTION

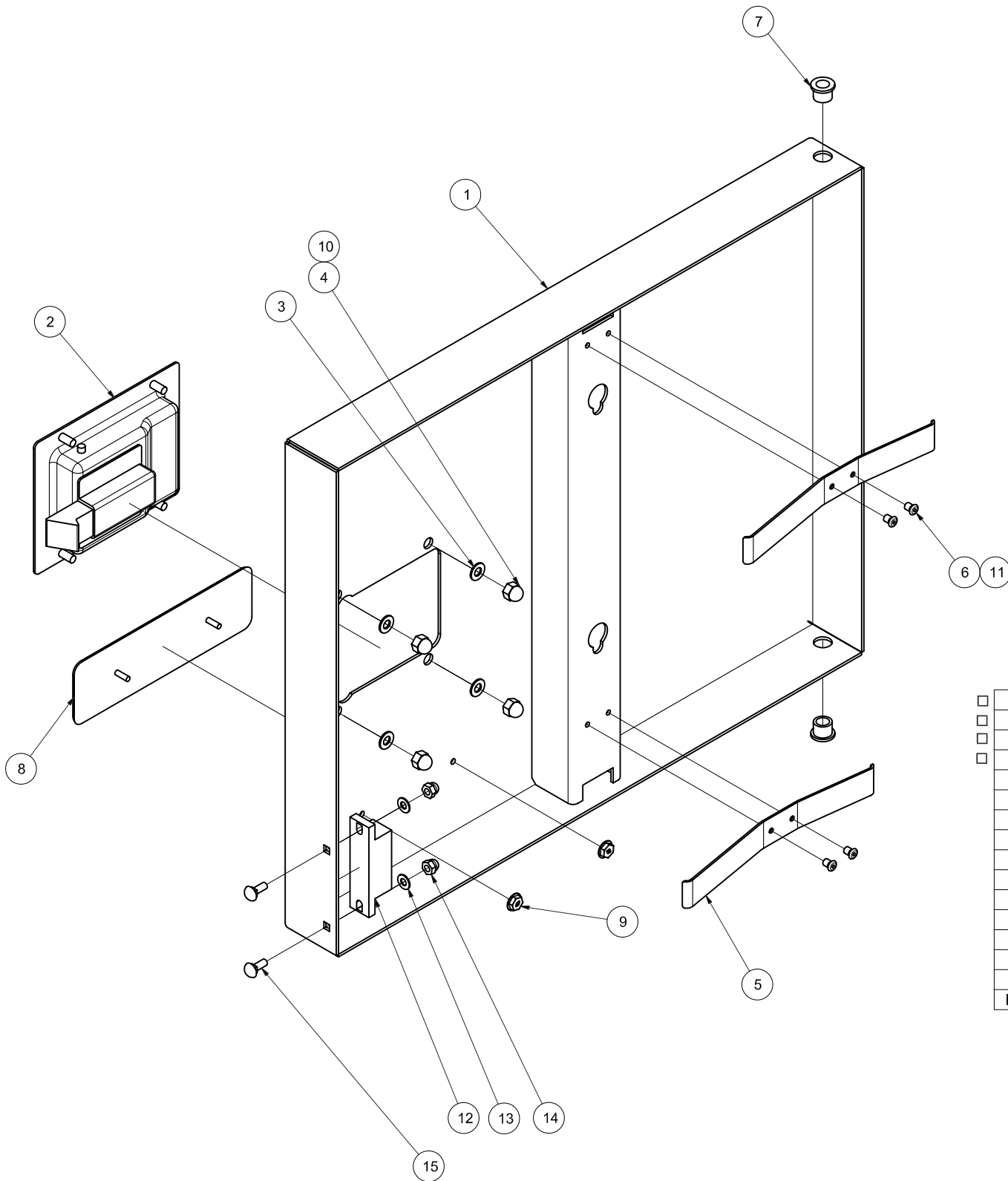

ITEM	QTY	PART NO.	DESCRIPTION
15	-	111592	SCREW, 8-32 X 1/2 CARRIAGE HEAD, SST
14	-	109164	NUT, HEX, ACORN, 8-32, SST, W/ THREAD LOC
13	-	101336	WASHER, FLAT, #8, SST
12	-	108879	MAGNET, DOOR STEAM CUTOFF
11	A/R	00933	SEALANT, RTV, CLEAR
10	A/R	104146	LOCKTITE #222 LOW STRENGTH
9	2	104987	NUT, WASHER STYLE, THD GC FOR 1/8 DIA STUD
8	1	105901	LABEL, NAMEPLATE, CLEVELAND, CAST
7	2	103641	BUSHING, DOOR HINGE
6	4	18357	RIVET, FLUSH BREAK, 0.125 DIA, 0.126/0.187 GRIP, SST
5	2	102228	SPRING, DOOR, 3/5 PAN
4	4	14679	NUT, #10-24 ACORN, SST
3	4	101655	WASHER, FLAT, #10, SST
2	1	103643	LATCH, DOOR-PADDLE TYPE
1	1	110485	OUTER DOOR, STEAMCHEF 3 WELDMENT - HINGED LEFT

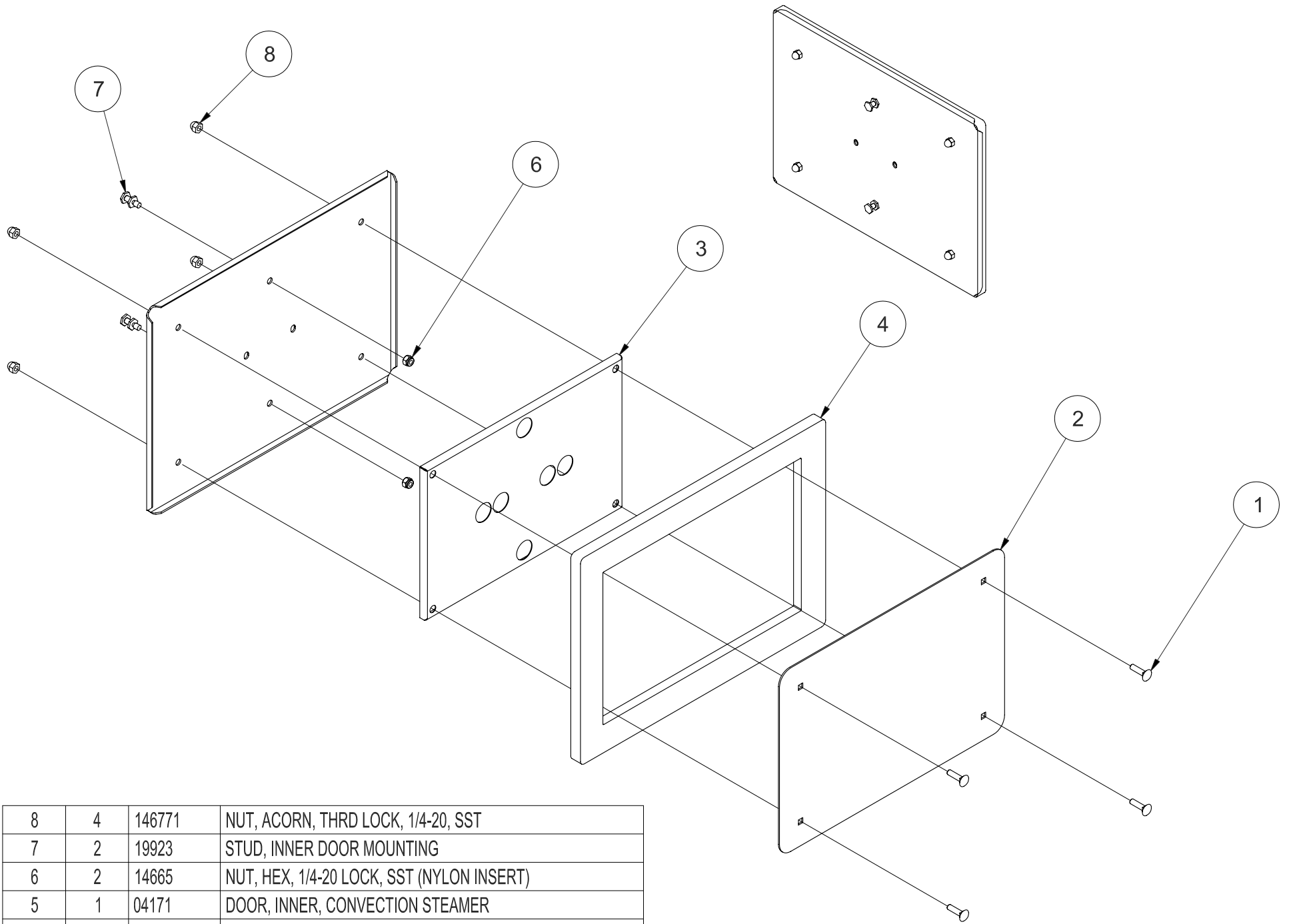

8	4	146771	NUT, ACORN, THRD LOCK, 1/4-20, SST
7	2	19923	STUD, INNER DOOR MOUNTING
6	2	14665	NUT, HEX, 1/4-20 LOCK, SST (NYLON INSERT)
5	1	04171	DOOR, INNER, CONVECTION STEAMER
4	1	07138	GASKET, DOOR, CONV. STMR., SC
3	1	66214	PLATE, INNER DOOR GASKET
2	1	66595	PLATE, GASKET RETAINER
1	4	104719	SCREW, CARRIAGE, 1/4-20X1, SST
ITEM	QTY	PART NO.	DESCRIPTION

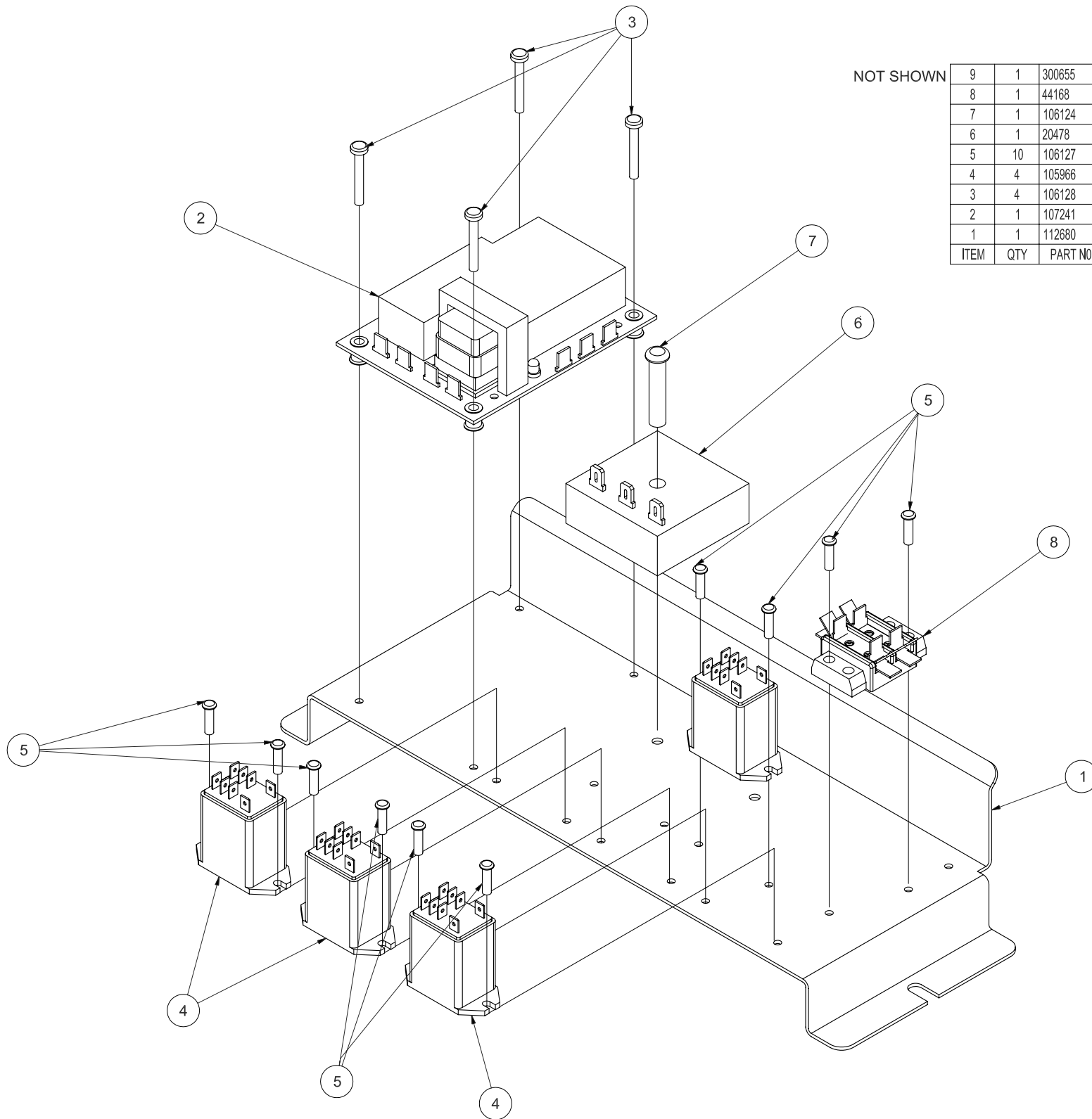

NOT SHOWN

9	1	300655	HARNESS, COMPONENT PANEL
8	1	44168	TERMINAL, BLOCK ASM, 2 POLE
7	1	106124	SCREW, TORX/SLOT #10-32 X 1-1/4 LG
6	1	20478	TIMER, SOLID STATE INTERV 3 MINUTE
5	10	106127	SCREW, 6-32 X 1/2, TORX/PAN HD
4	4	105966	RELAY, DPDT-W/MTG TABS
3	4	106128	SCREW, 6-32 X 1 TORX/PAN HD
2	1	107241	BOARD, WATER LEVEL CONTROL
1	1	112680	PLATE, COMPONENT MOUNTING, STEAMCHEF, HL
ITEM	QTY	PART NO.	DESCRIPTION

# 3.1 / 6.1 EnergyStar SteamChef's

## TIMER OPT.

### MECHANICAL

- 110198 MOTOR TIMER
- 110199 KNOB
- 20477 3 SEC SS TIMER
- 41350 BUZZER

### ELECTRONIC

- 104389 NCC TIMER
- 104390 24V TRANSF
- 106909 FUSE, 2AMP

### ON / OFF

- 102534 SWT, SELECTOR
- 102533 CONTACT BLOCK
- 41350 BUZZER

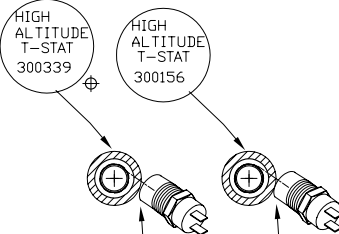

300150	60 MIN SS TIMER	109152	HIGH LIMIT DISC
300677	T-STAT, 193 drg	3003231	DUAL PROBE ASY
107241	WATERBOARD	03506	75AMP CONTACTOR
105966	RELAY DPDT, 120V	106288	T-STAT, DRAIN, 140 drg
03509	50AMP CONTACTOR	300255	CIRCUIT BREAKER, 1.5AMP
300254	TRANSFORMER, 200VA	109374	FUSE BLOCK, 2POLE, 30AMP
109617	T-STAT, 205 drg	109380	FUSES, 3.5AMP, 600VA
20478	3 MIN SS TIMER	104224	SWITCH, ROCKER, DPDT, MATTE
44168	T-BLOCK, 2 POLE	22218	SOLENOID, 1/4" NC, 120V
109494	NEON LIGHT, GREEN	110613	ON/OFF, BALL VALVE, HARNESS
12159	NEON LIGHT, RED	110683	BLOWER MOTOR, use FK110683
109602	NEON LIGHT, AMBER	108171	BLOWER WHEEL

## HEAT BLOCKS

VOLT	PART No.	Description
208	300186 - 3KW	- 2 WIRE, CAST BLOCK
240	3001861 - 3KW	- 2 WIRE, CAST BLOCK
480	3001862 - 3KW	- 2 WIRE, CAST BLOCK
208	300185 - 2KW	- 2 WIRE, CAST BLOCK
240	3001851 - 2KW	- 2 WIRE, CAST BLOCK
480	3001852 - 2KW	- 2 WIRE, CAST BLOCK
6.1 ONLY (13.5KW)	240 3003301 - 4.5KW	- 2 WIRE, CAST BLOCK
6.1 ONLY (13.5KW)	480 300330 - 4.5KW	- 2 WIRE, CAST BLOCK
208VOLT	6.1 ONLY (13.5KW)	- 109123 DRILLED BLOCK
208VOLT	300242 -1500watt ea.	- ROD HEATER (3ea per block)

## DOOR PARTS

- 103643 HANDLE / LATCH
- 07138 3-DOOR GASKET
- 110830 6-DOOR GASKET
- 108880 DOOR SWITCH
- 108879 DOOR MAGNET
- 111592 CARRIAGE BOLT
- 109164 ACORN NUT SM

WELD SEAM

+

+

+

+

+

+

+

+

+

+

+

+

+

+

+

+

+

+

+

+

+

+

+

+

+

+

+

\*

- 1091391 - HEATER COMPOUND 2oz TUBE
- 109134 - RAIL, CHANNEL BLOCK MOUNT
- 23116 - FLAT WASHER
- 109482 - CASTLE NUT, SELF LOCK 1/4-20
- 111484 - HIGH LIMIT SCREWS, SELF DRILL

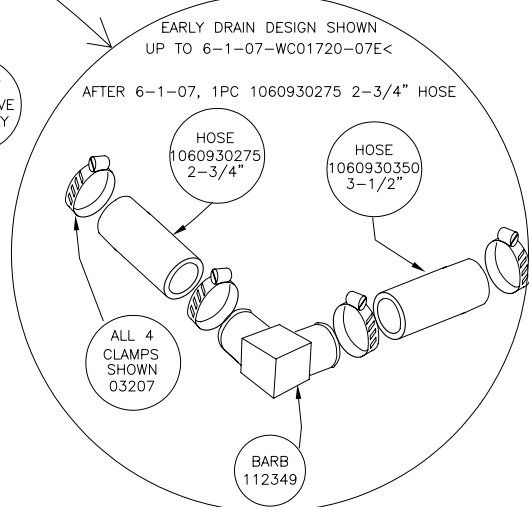
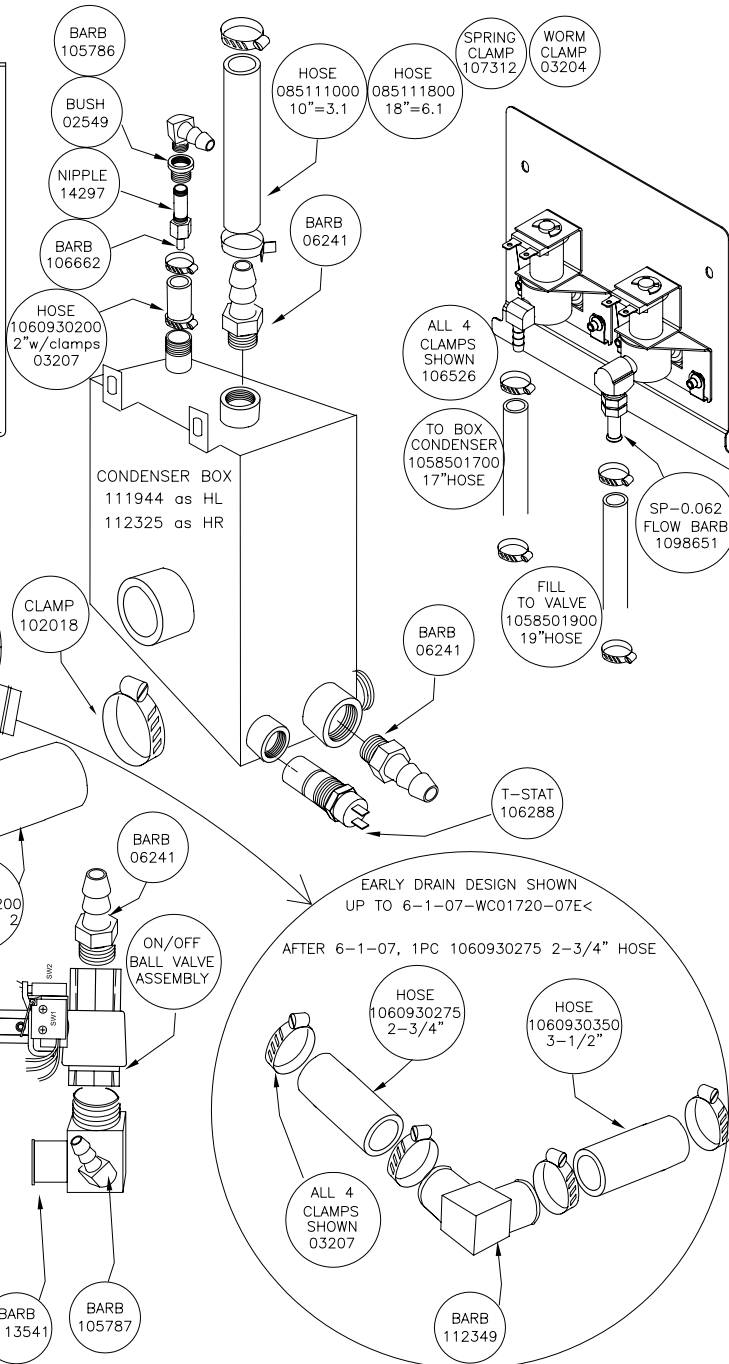
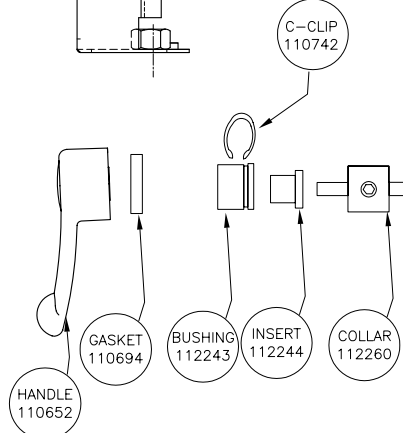

208/240/480V  
CUSTOMER  
CONNECTION

# STEAMCHEF 3.1/6.1 MECH TIMER (THREE PHASE)

208/240/480V  
CUSTOMER  
CONNECTION

3 Ø  
(SEE RATING PLATE)

(SEE RATING PLATE)

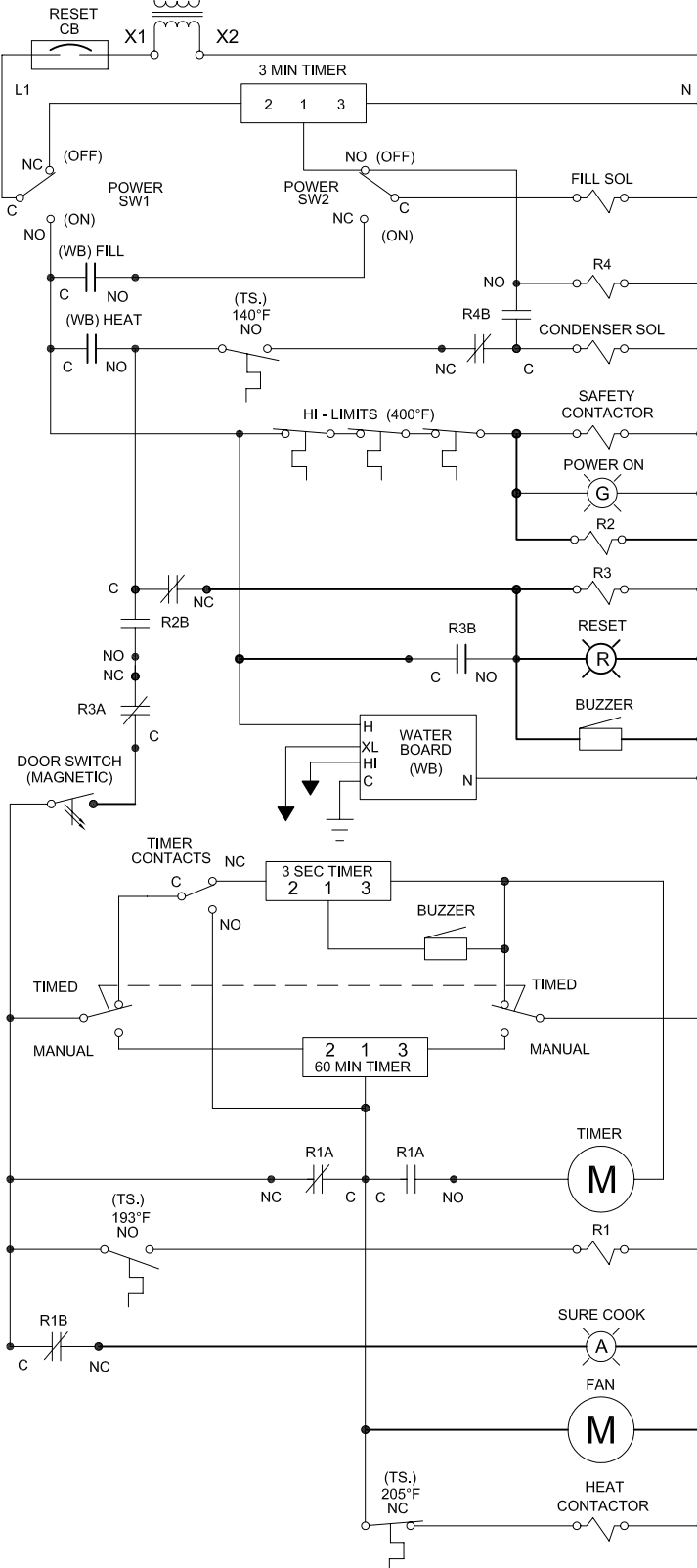
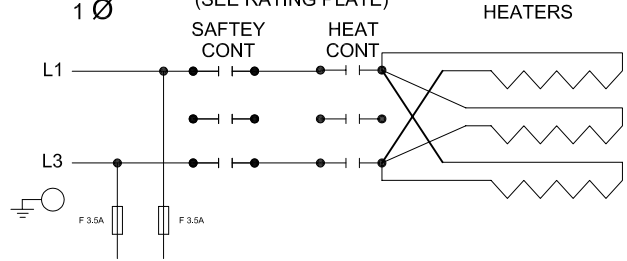
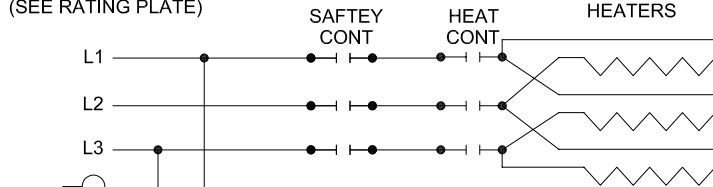

## ITEM PART No.

## HEAT BLOCKS

- 1 110198
- 2 300150
- 3 19972
- 4 107241
- 5 105966
- 6 03509
- 7 300254
- 8 109617
- 9 20477
- 10 44168
- 11 41350
- 12 108880
- 13 109602
- 14 109152
- 15 3003231
- 16 106288
- 17 300255
- 18 109374
- 19 109380
- 20 109494
- 21 12159
- 22 104224
- 23 22218
- 24 110613
- 25 110683
- 26 20478

ITEM	V	PART No.
27	208	300186 - 3KW
	240	3001861 - 3KW
	480	3001862 - 3KW
	208	300185 - 2KW
	240	3001851 - 2KW
	480	3001852 - 2KW
6.1 ONLY (13.5KW)		
	240	3003301 - 4.5KW
	480	300330 - 4.5KW

3.5A 600V



# STEAMCHEF 3.1/6.1 MECH TIMER 3 PHASE (SINGLE PHASE SEE SHEET 2)

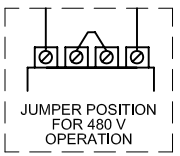
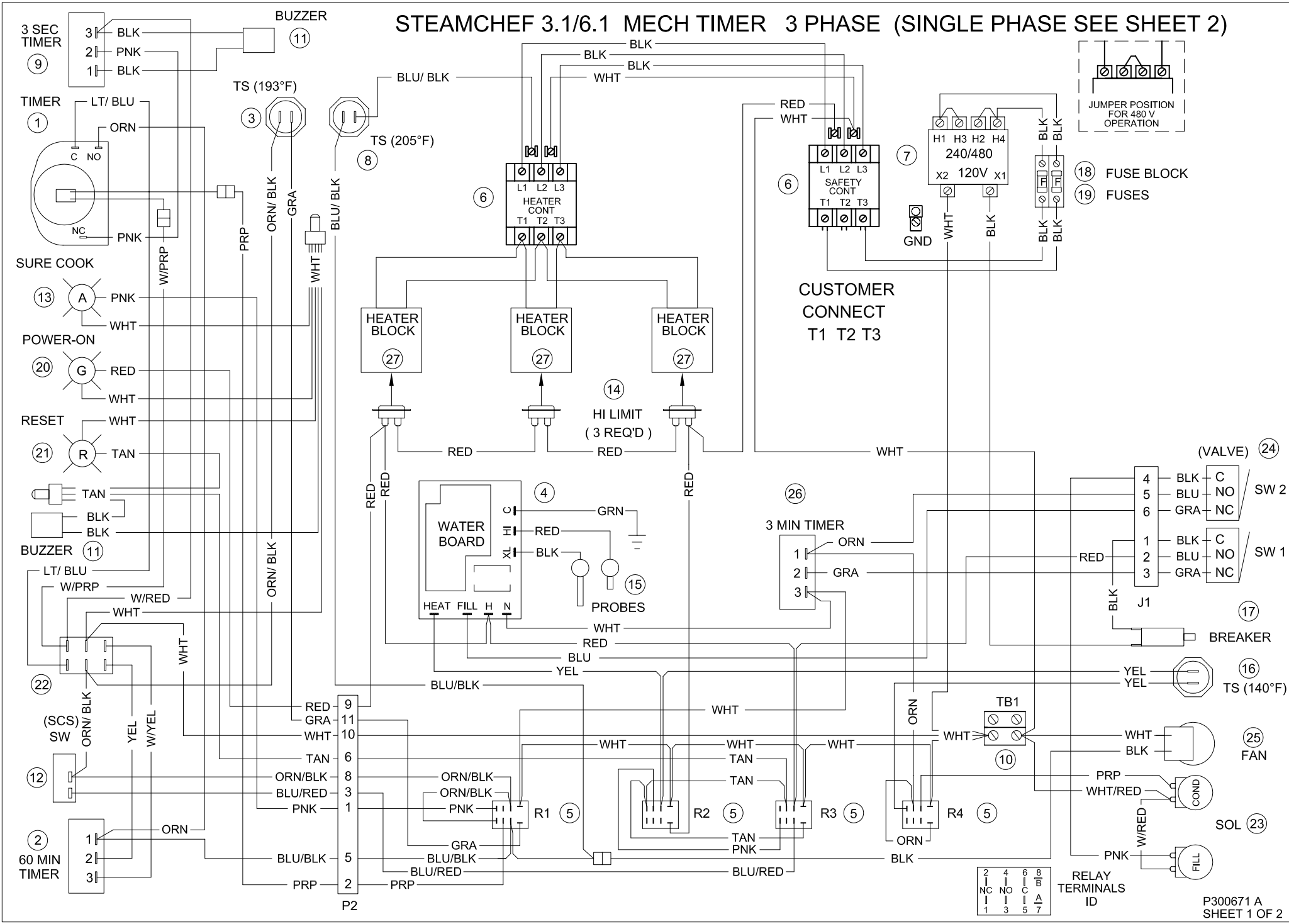

18 FUSE BLOCK  
19 FUSES

CUSTOMER CONNECT  
T1 T2 T3

14 HI LIMIT  
(3 REQ'D)

(VALVE) 24

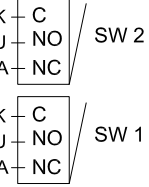

17 BREAKER

16 TS (140°F)

25 FAN

SOL 23

FILL

RELAY TERMINALS ID

2	4	6	8
NC	NO	C	B
1	3	5	7

240/480V  
CUSTOMER  
CONNECTION

# STEAMCHEF 3.1 / 6.1 ON/OFF CONTROL

208/240/480V  
CUSTOMER  
CONNECTION

3 Ø  
(SEE RATING PLATE)

(SEE RATING PLATE)

HEATERS

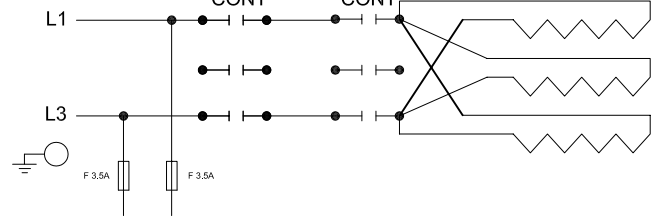
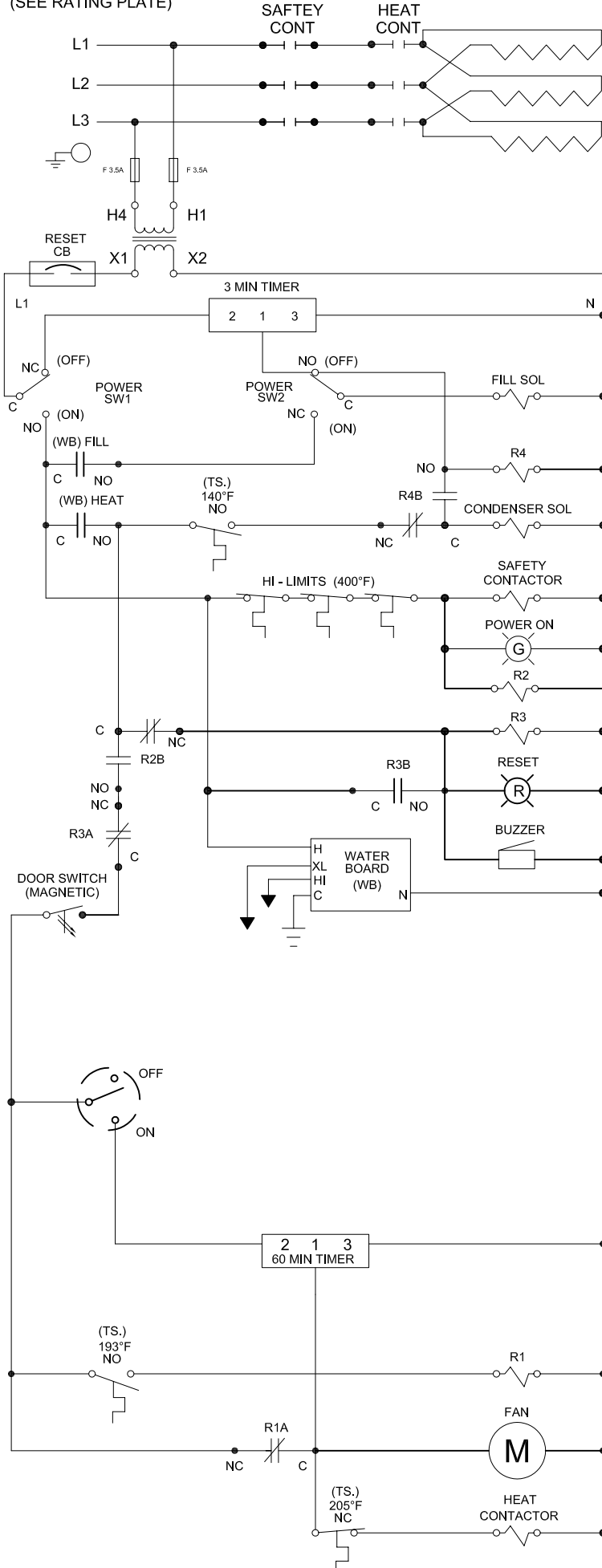

# STEAMCHEF 3.1/ 6.1 ON / OFF CONTROL ( THREE PHASE )

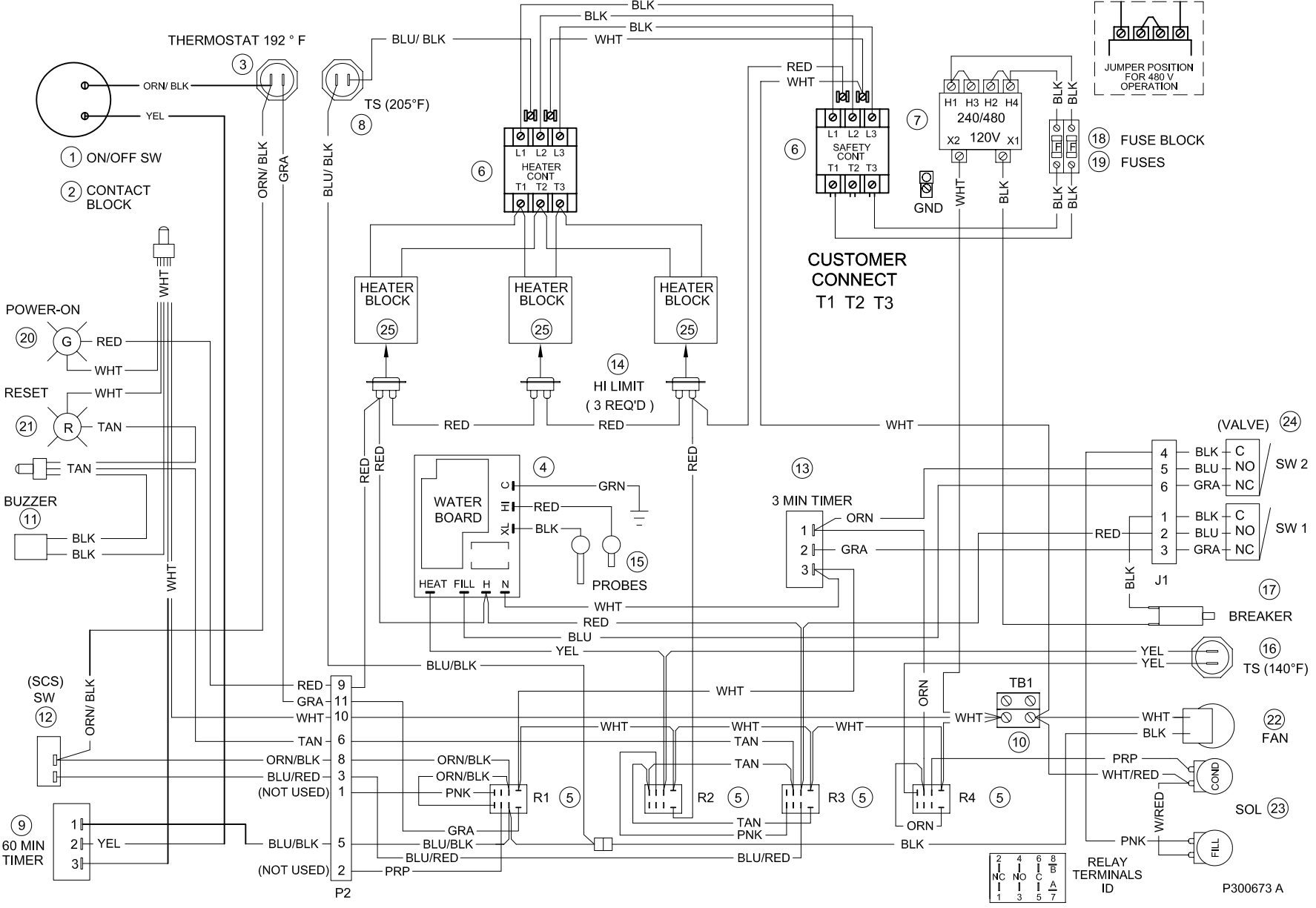

**ITEM PART No.**

- 1 102534
- 2 102533
- 3 19972
- 4 107241
- 5 105966
- 6 03509
- 7 300254
- 8 109617
- 9 300150
- 10 44168
- 11 41350
- 12 108880
- 13 20478
- 14 109152
- 15 3003231
- 16 106288
- 17 300255
- 18 109374
- 19 109380 3.5A 600V
- 20 109494
- 21 12159
- 22 110683
- 23 22218
- 24 110613

**HEAT BLOCKS**

- | ITEM | V   | PART No.      |
|------|-----|---------------|
| 25   | 208 | 300186 - 3KW  |
|      | 240 | 3001861 - 3KW |
|      | 480 | 3001862 - 3KW |
|      | 208 | 300185 - 2KW  |
|      | 240 | 3001851 - 2KW |
|      | 480 | 3001852 - 2KW |

**6.1 ONLY (13.5KW)**

- 240 3003301 - 4.5KW
- 480 300330 - 4.5KW

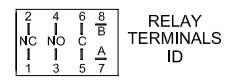
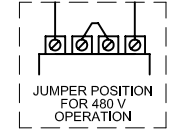

P300673 A