

**CLEVELAND RANGE INC.
STEAMCRAFT POWER 10
DIRECT CONNECT**

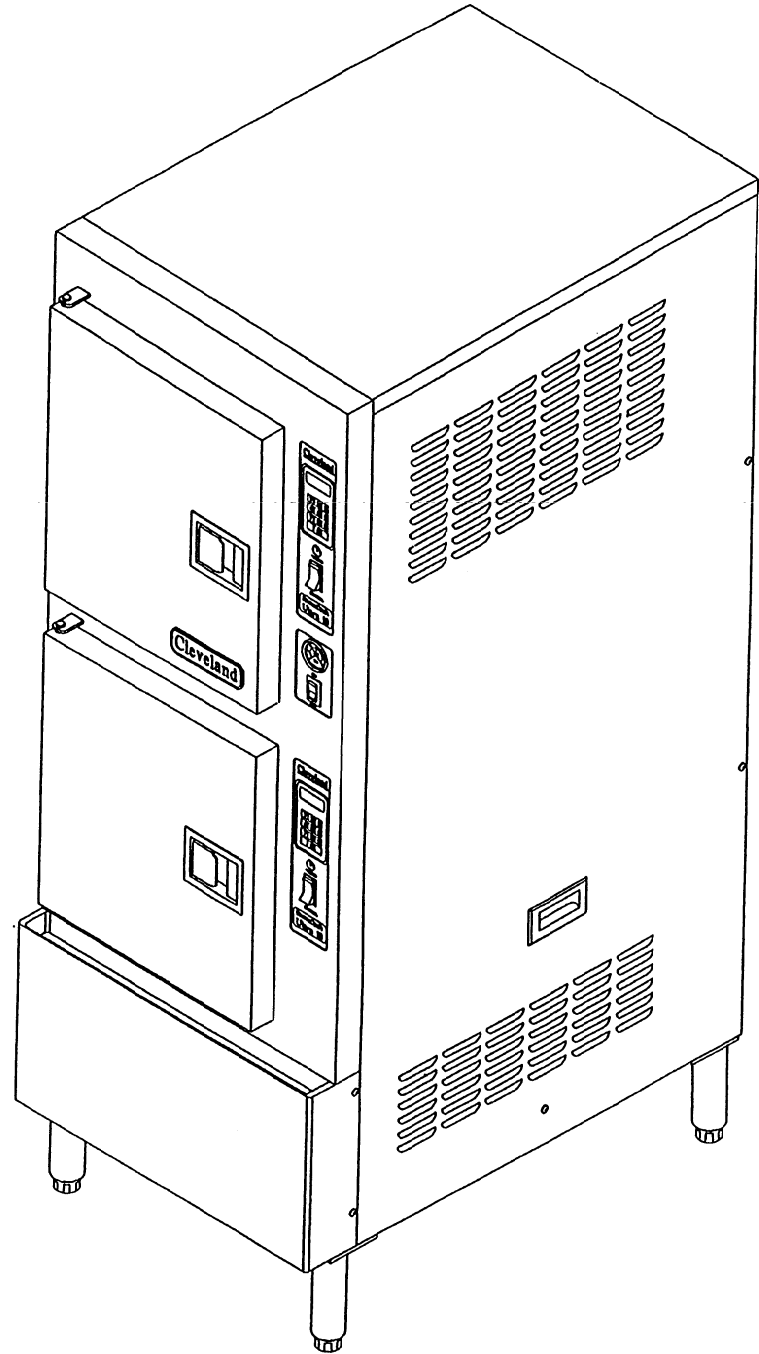

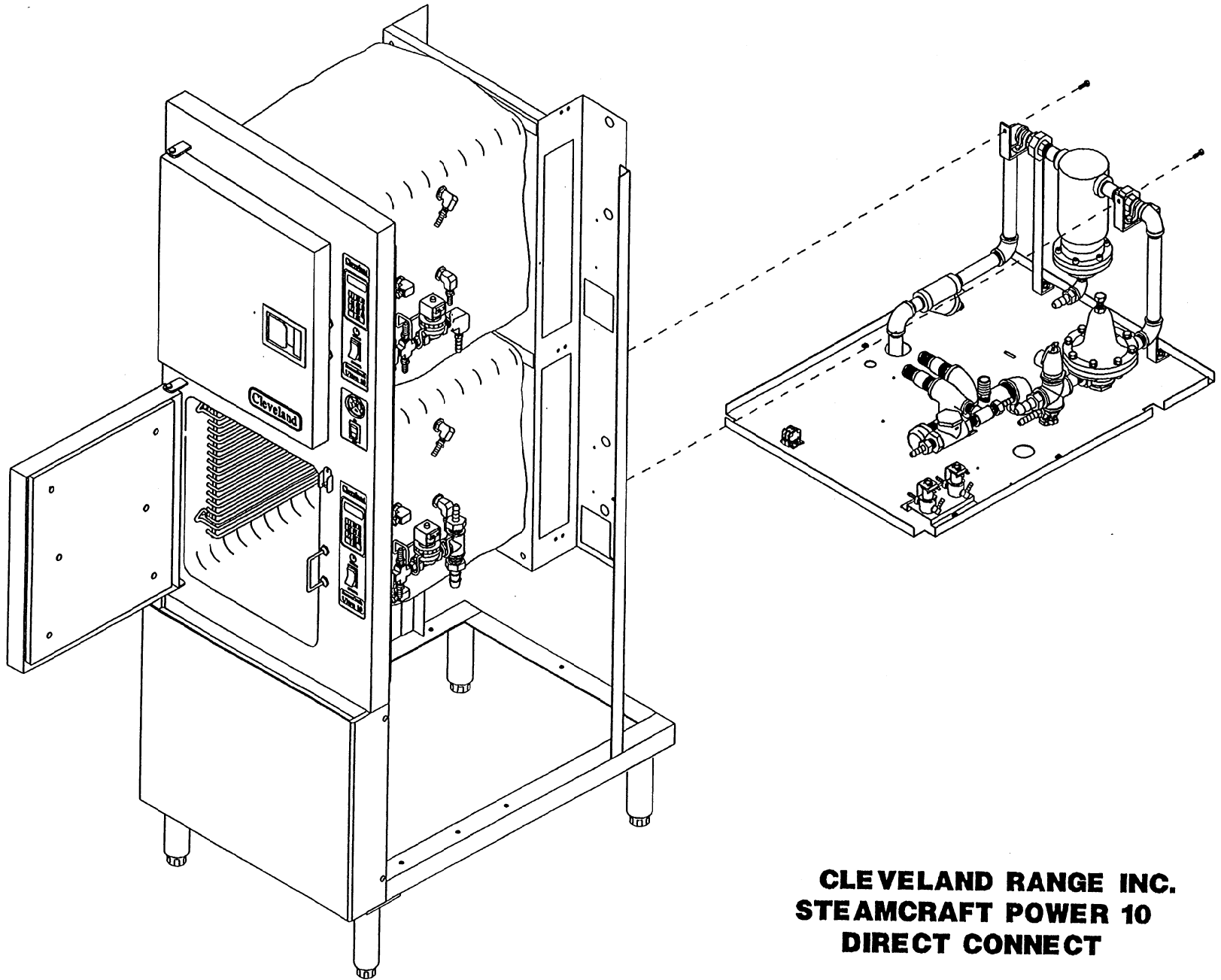

**CLEVELAND RANGE INC.
STEAMCRAFT POWER 10
DIRECT CONNECT**

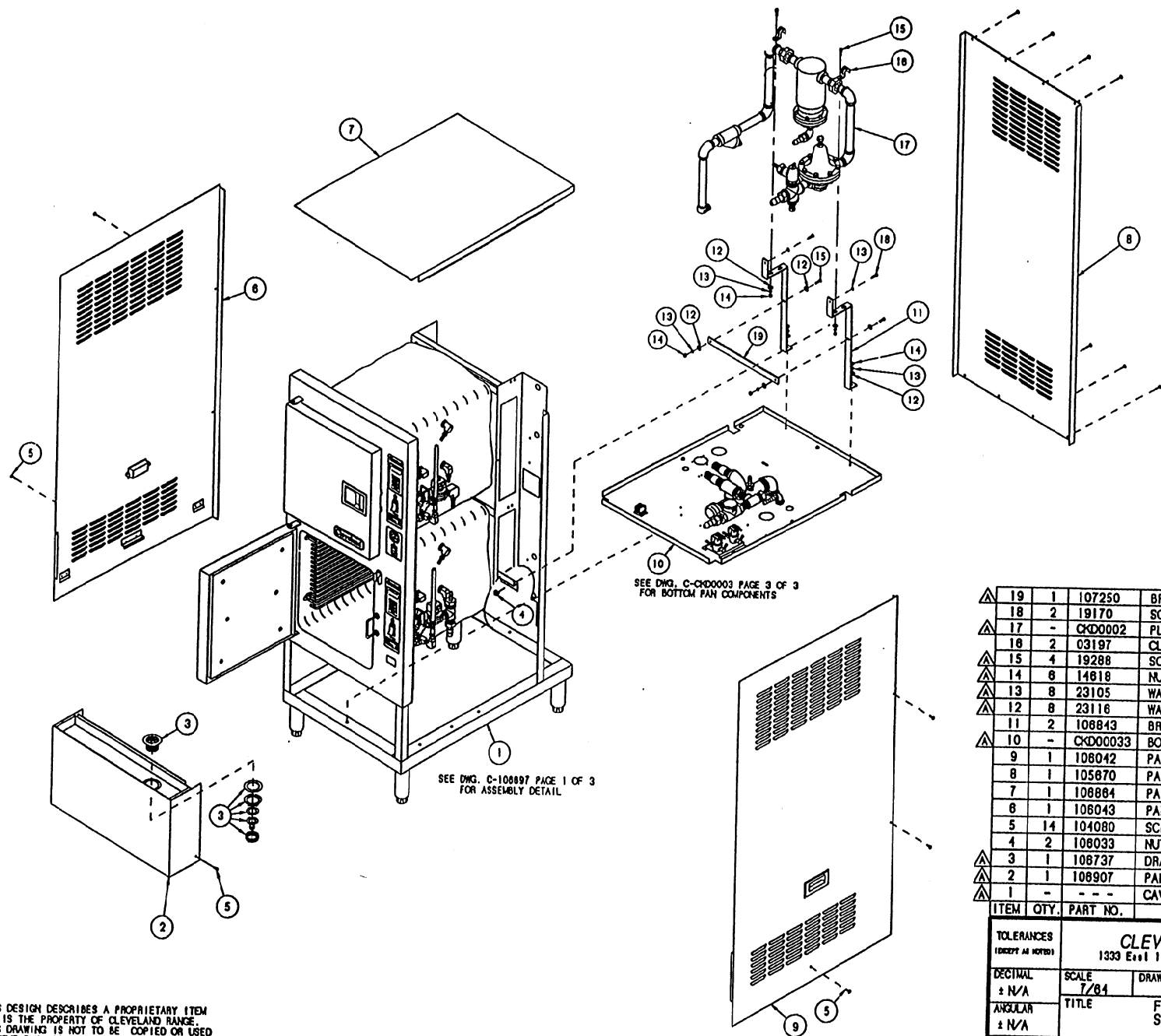

SEE DWG. C-CKD0003 PAGE 3 OF 3 FOR BOTTOM PAN COMPONENTS

SEE DWG. C-108897 PAGE 1 OF 3 FOR ASSEMBLY DETAIL

△	19	1	107250	BRACKET, SUPPORT, PLUMBING
	18	2	19170	SCREW, HEX, 1/4-20 X 5/8
△	17	-	CKD0002	PLUMBING, SC 10, DIRECT CONNECT
	16	2	03197	CLAMP, RIGID 3/4" HOLE
△	15	4	19288	SCREW, HEX, 1/4-20 X 3/4
△	14	8	14818	NUT, HEX 1/4-20
△	13	8	23105	WASHER, LOCK, 1/4"
△	12	8	23116	WASHER, FLAT 1/4 X 5/8 X .085
	11	2	108843	BRACKET, SUPPORT, SC 10 DC
△	10	-	CKD00033	BOTTOM PAN COMPONENTS ASSEMBLY
	9	1	108042	PANEL ASSY, SIDE, RIGHT, SC 10
	8	1	105870	PANEL, BACK, SC 10
	7	1	108864	PANEL, TOP, SC 10 ELECTRIC
	6	1	108043	PANEL ASSY, SIDE, LEFT, SC 10
	5	14	104080	SCREW, TRUSS HD. SHT. MET. #8 X 1/2
	4	2	108033	NUT, TINNEMAN
△	3	1	108737	DRAIN ASSY, TABLETOPS AND SC 10
△	2	1	108907	PANEL ASSY, LOWER FRONT, 4"
△	1	-	-	CAVITY ASSEMBLY WITH DOORS, SC 10
	ITEM	QTY.	PART NO.	DESCRIPTION

<p>CLEVELAND RANGE INC. 1339 East 179th St. Cleveland, Ohio 44110-2574</p>			
<p>TOLERANCES (EXCEPT AS NOTED)</p>	<p>SCALE 7/84</p>	<p>DRAWN BY DUTCHMAN</p>	<p>APPROVED BY</p>
<p>DECIMAL ± N/A</p>	<p>TITLE FINAL ASSEMBLY, H.L. STEAMCRAFT POWER 10 DIRECT CONNECT</p>		
<p>ANGULAR ± N/A</p>	<p>DATE 03-17-94</p>	<p>DRAWING NO. C - CKD0003</p>	<p>PAGE 2 OF 3 REV. A</p>

THIS DESIGN DESCRIBES A PROPRIETARY ITEM AND IS THE PROPERTY OF CLEVELAND RANGE. THIS DRAWING IS NOT TO BE COPIED OR USED WITHOUT THE APPROVAL OF CLEVELAND RANGE.

NOTES:

- 1.1 SEE DRAWING A HOSE DETAIL.
- 2.1 SEE INSTRUCTION DRAWING CKD0003 FOR LABELS AND LABEL LOCATIONS.
- 3.1 REVISION SYMBOLS (Δ) ARE PLACED NEXT TO AFFECTED ITEM NO. IN BILL OF MATERIALS ONLY.
- 4.1 FOR STEAM CUT-OFF SWITCH OPTION SEE DRAWING 108518 FOR LOCATION OF HOLES IN FACEPLATE AND DRAWING 108355 FOR PICTORIAL WIRING INFO.

LET.	REVISIONS	DATE	BY
A	SEE E.O. #C-2882	2-05-94	PJD

TABLE I
STEAM SHUT-OFF OPTION

ITEM NO.	QUANTITY
105449 SCREW	20 4
105442 GUARD	25 2
104196 SWITCH	25 2
1085832 DOOR	2 1
104202 DOOR	2 2
1042082 DOOR	1 1

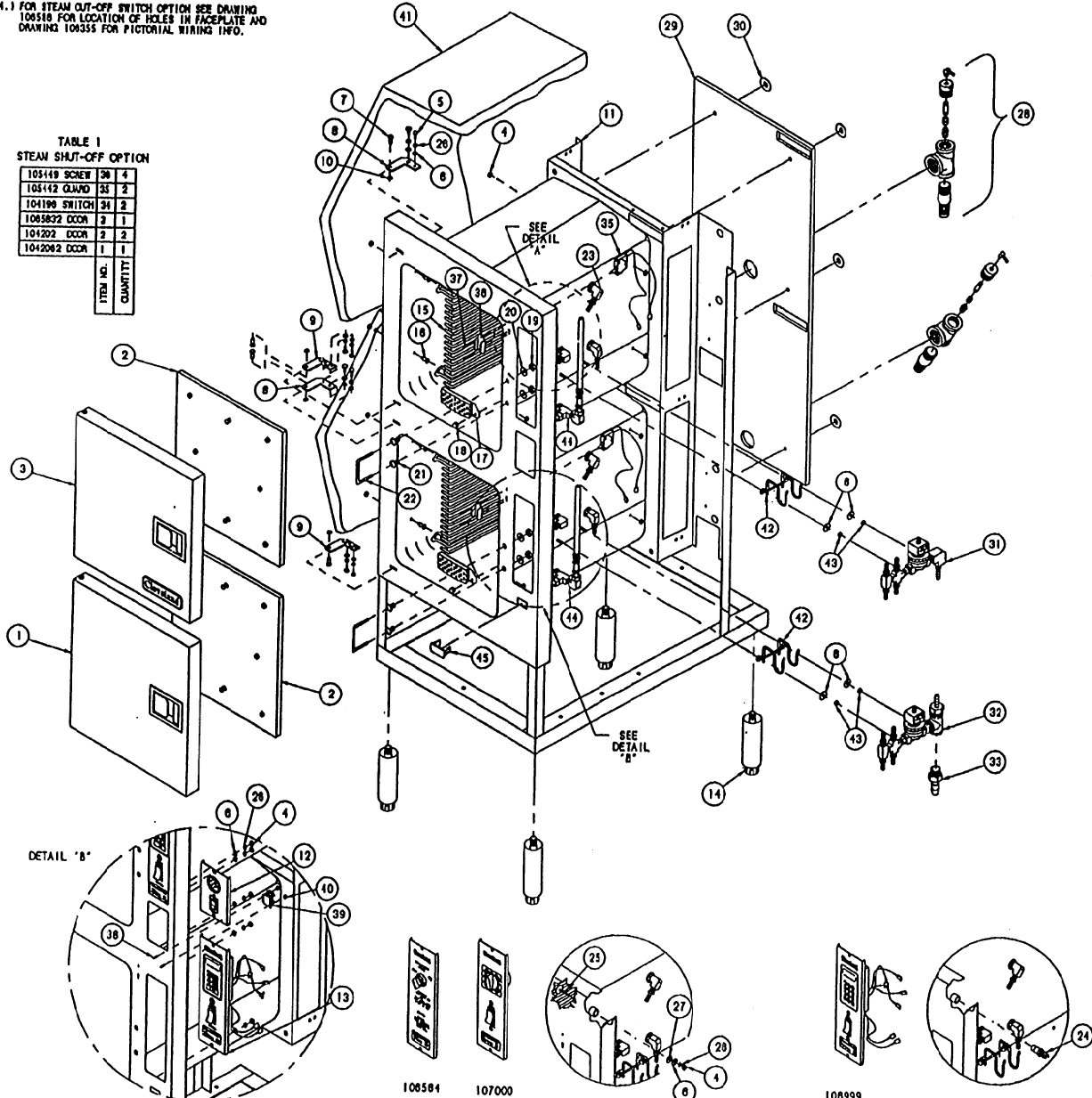

ITEM	QTY.	PART NO.	DESCRIPTION
45	1	105441	PLUG, SWITCH BLANK, MATTE
44	2	107059	BREATHER/STEAM NOZZLE ASSY. (3/8" HOSE)
43	4	14892	NUT, ELASTIC LOCK, #10-24
42	2	108732	BRACKET, WIRE, VALVE SUPPORT
41	2	104193	INSULATION, BODY, CUT
40	2	104223	NUT, ELASTIC LOCK, 8-32
39	1	44188	TERMINAL BLOCK, 2-POLE
38	2	19926	STUD, WELD, 8-32 X 1/2, S/S
37	-	105449	SCREW, TRUSS HD, 8-32 X .312, S/S
36	-	105442	GUARD, SWITCH PROTECTION
35	-	104196	SWITCH ASSY, CAPT. STEAM SHUT-OFF
34	-	108819	WIRE HARNESS, ON/OFF, SC10
-	-	108818	WIRE HARNESS, MECH. CONTROL, SC 10
-	-	108817	WIRE HARNESS, ELECT. CONTROL, SC 10
33	1	08240	FITTING, HOSE BARB 3/4 H X 3/4 MPT
32	1	108892	STEAM INLET ASSY, LOWER COMPARTMENT
31	1	108891	STEAM INLET ASSY, UPPER COMPARTMENT
30	6	101953	CLIP, INSULATION RETAINER
29	1	108235	INSULATION, BODY REAR
28	2	1081711	DRAIN ASSEMBLY, SC 10
27	2	23136	WASHER, FLAT 3/8 X 7/8 X 1/16 THK.
26	16	23105	WASHER, LOCK S/S 1/4 KATLINK STYLE
25	2	104409	CLOSURE, THERMAL OPENING
24	2	19972	SWITCH, THERMAL CLOSE
23	6	1082301	STEAM NOZZLE ASSY, STEAMCRAFT
22	2	104046	CATCH, DOOR
21	4	14895	NUT, DOOR CATCH MOUNTING, S/S
20	4	23149	WASHER, NYLON, TYPE 6/8
19	4	14849	NUT, HEX 1/2-13, ZINC PLATED
18	2	14877	NUT, ACOH
17	2	69298	SCREEN, COMPARTMENT DRAIN, POLYPROP
16	16	101305	PIN, RACK
15	4	414232	RACK, PAN SLIDE, 18"
14	4	08158	LEG, BULLEY
-	-	108584	TIMER ASSY, ON/OFF CONTROL, SC 10
13	-	107000	TIMER ASSY, MECH. CONTROL, SC 10
-	-	108999	TIMER ASSY, ELECTRIC CONTROL, SC 10
12	1	108704	PANEL ASSEMBLY, POWER SWITCH, SC 10 DC
11	1	105881	CAVITY WELD ASSY, STEAMCRAFT 10
10	4	104082	RING, SHAP, S/S
9	2	1040431	HINGE ASSY, WELD, LOWER
8	2	1040732	HINGE ASSY, WELD, UPPER
7	4	104077	PIN, HINGE
6	20	23116	WASHER, FLAT 1/4 ID X 5/8 OD, S/S
5	8	19170	SCREW, HEX HD, 1/4-20 X 5/8 S/S
4	24	14818	NUT, HEX 1/4-20 S/S
3	-	1085832	DOOR, OUTER ASSY, H.L. W/LOGO, W/ACTUATOR
-	-	108583	DOOR, OUTER ASSY, H.L. W/LOGO
2	2	104202	DOOR, INNER ASSY, H.L.
1	-	1042082	DOOR, OUTER ASSY, H.L. W/ACTUATOR
-	-	104206	DOOR, OUTER ASSY, H.L.

THIS DESIGN DESCRIBES A PROPRIETARY ITEM AND IS THE PROPERTY OF CLEVELAND RANGE. THIS DRAWING IS NOT TO BE COPIED OR USED WITHOUT THE APPROVAL OF CLEVELAND RANGE.

108584
ON/OFF
CONTROL

107000
MECHANICAL
CONTROL

THERMAL SWITCH CLOSURE
(MECHANICAL & ON/OFF)

108999
ELECTRONIC
CONTROL

THERMAL SWITCH
(ELECTRONIC OPTION)

TIMER OPTIONS - DETAIL A

TOLERANCES (EXCEPT AS NOTED)		CLEVELAND RANGE INC. 1333 East 179th St. Cleveland, Ohio 44110-2574	
DECIMAL ± N/A	SCALE 1/8	DRAWN BY DUTCHMAN	APPROVED BY
ANGULAR ± N/A	TITLE FINAL ASSEMBLY, H.L. STEAMCRAFT POWER 10 DIRECT CONNECT		
CK	DATE 03-17-94	DRAWING NO. C - CKD0003	PAGE 1 OF 3 REV. A

NOTES:

1.1 RELATIVE POSITION OF OBJECTS ARE NOT REPRESENTATIVE OF INSTALLED LOCATIONS.

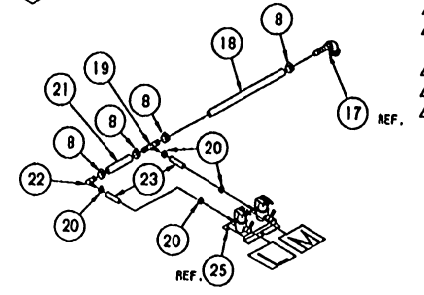
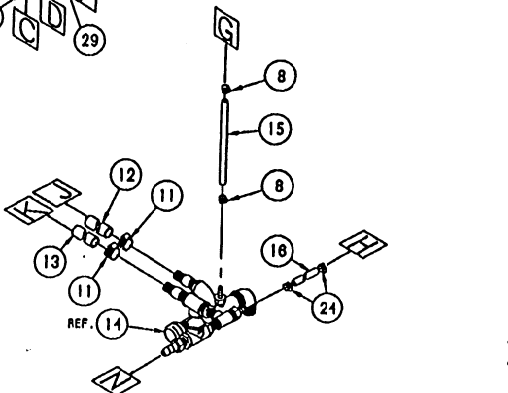
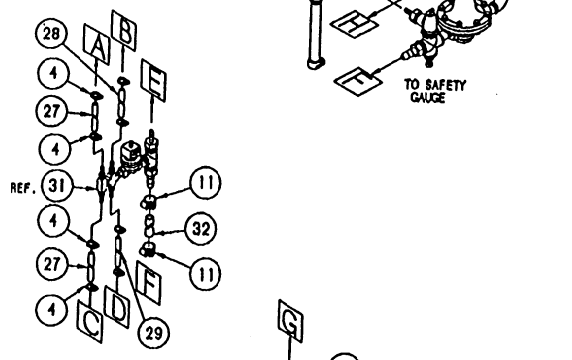
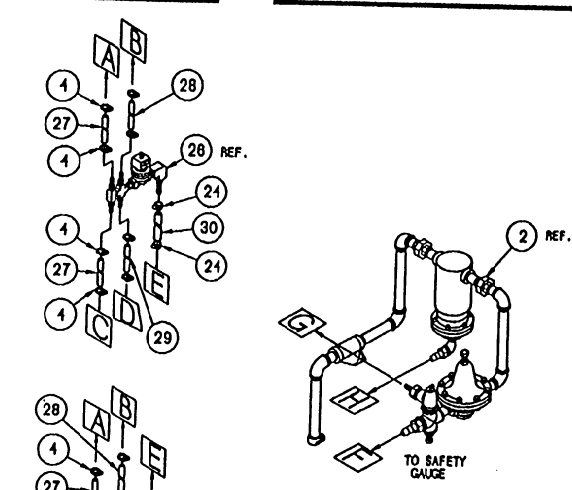
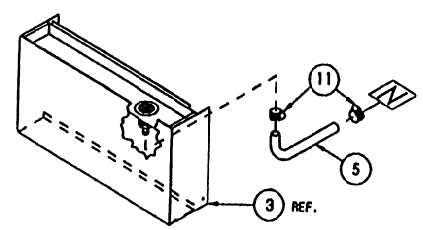
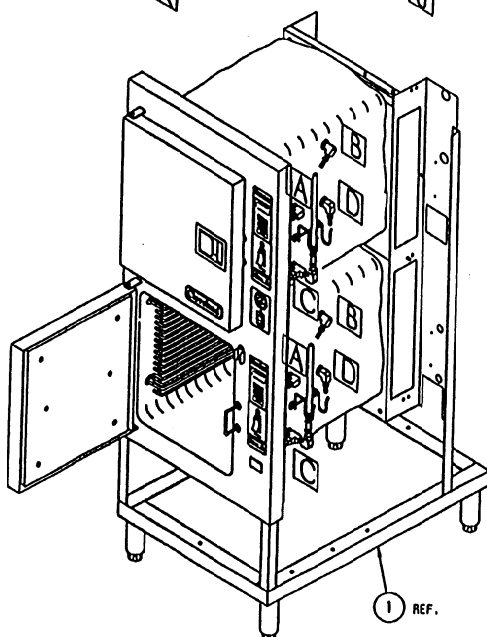
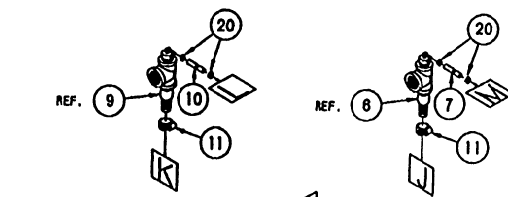

LET.	REVISIONS	BY
A	SEE E.O. 12-2882	2-04-94 PJD

ITEM	QTY.	PART NO.	DESCRIPTION
32	1	085051500	HOSE, DARIPREEN 3/4 ID X 15' LG.
31	-	108892	STEAM INLET ASSY, LOWER COMPARTMENT
30	1	085041950	HOSE, DARIPREEN 1/2 ID X 3/4 CD X 19.500
29	2	1052791050	HOSE, SILICONE 3/8 ID X 10.500" LG
28	2	1052791200	HOSE, SILICONE 3/8 ID X 12" LG
27	4	1052790475	HOSE, SILICONE 3/8 ID X 4.750" LG
26	-	108891	STEAM INLET ASSY, UPPER COMPARTMENT
25	-	105987	WATER INLET ASSY
24	4	03208	CLAMP, WORM DRIVE, 1/2 TO 29/32 DIA.
23	2	1058500200	HOSE, NT-80, 1/4 ID X 1/2 CD X 2" LG
22	1	105792	FITTING, ELBOW 90°, 1/4 H X 1/2 H
21	1	1058490300	HOSE, NT-80 1/2 ID X 3/4 CD X 3.000 LG
20	8	108528	CLAMP, WORM DRIVE, 3/16 TO 5/16 DIA.
19	1	105790	FITTING, TEE 1/2 H X 1/2 H X 1/4 H
18	1	1058491150	HOSE, NT-80 1/2 ID X 3/4 CD X 11.500
17	-	-	WATER INLET ASSY.
16	1	085041850	HOSE, DARIPREEN, 1/2" ID X 18.500" LG.
15	1	085040900	HOSE, DARIPREEN, 1/2" ID X 9" LG.
14	-	108815	DRAIN MANIFOLD ASSY, SC POWER 10
13	1	1054894100	HOSE, EPDM, BLACK, 1" ID X 41" LG.
12	1	1054891900	HOSE, EPDM, BLACK, 1" ID X 19" LG.
11	8	03204	CLAMP, WORM DRIVE .812" TO 1.500" DIA.
10	1	1058504800	HOSE, NT-80, 1/4 ID X 1/2 CD X 48" LG
9	1	-	COMPARTMENT DRAIN ASSY, SC 10, UPPER
8	6	108219	CLAMP, WORM DRIVE, 1/4 TO 25/32 DIA.
7	1	1058503100	HOSE, NT-80, 1/4 ID X 1/2 CD X 31" LG
6	1	-	COMPARTMENT DRAIN ASSY, SC 10, LOWER
5	1	107010	HOSE, TRAY DRAIN, 3/4" I.D. BLACK EPDM
4	18	105278	CLAMP, HOSE, NYLON, 5/8" CD HOSE
3	-	-	PANEL ASSY, LOWER FRONT, 4"
2	-	-	PLUMBING, SC POWER 10, DIRECT CONNECT
1	-	-	CAVITY ASSY. WITH DOORS, SC 10

TOLERANCES (EXCEPT AS NOTED)		CLEVELAND RANGE INC. 1333 East 179th St. Cleveland, Ohio 44110-2574	
DECIMAL ± N/A	SCALE NTS	DRAWN BY Dutchman	APPROVED BY Dodson
ANGULAR ± N/A	TITLE HOSE DETAIL, H.L. STEAMCRAFT POWER 10 DIRECT CONNECT		
CK	DATE 03-17-94	DRAWING NO. C - CKD0004	REV. A

THIS DESIGN DESCRIBES A PROPRIETARY ITEM AND IS THE PROPERTY OF CLEVELAND RANGE. THIS DRAWING IS NOT TO BE COPIED OR USED WITHOUT THE APPROVAL OF CLEVELAND RANGE.

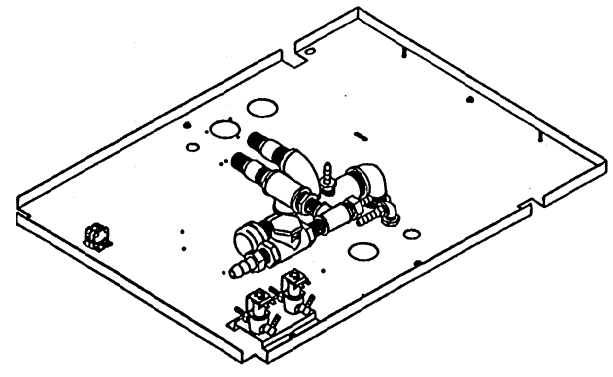
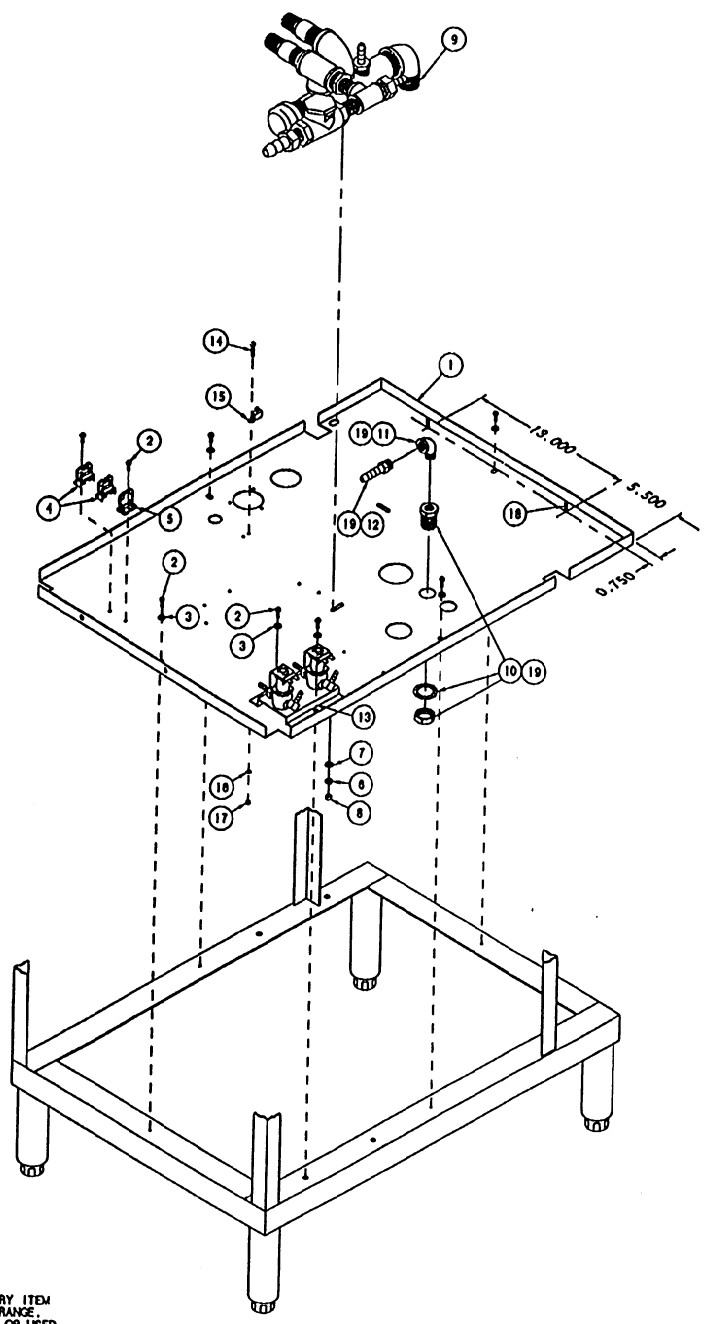

CAVITY WELD ASSY. (REF.)

THIS DESIGN DESCRIBES A PROPRIETARY ITEM AND IS THE PROPERTY OF CLEVELAND RANGE. THIS DRAWING IS NOT TO BE COPIED OR USED WITHOUT THE APPROVAL OF CLEVELAND RANGE.

ITEM	QTY.	PART NO.	DESCRIPTION
19	A/R	00934	ADHESIVE, RECTORSEAL
18	2	19898	STUD, WELD, 1/4-20 X 5/8", S/S
17	1	14859	NUT, HEX 10-24, S/S
18	1	23114	WASHER, LOCK, INT. TOOTH #10
15	1	20304	LUG, GROUND, SOLDERLESS
14	1	19287	SCREW, RD HD SLTD, #10-24 X 1/2
13	1	105987	WATER INLET ASSY.
12	1	100746	FITTING, HOSE, 3/8 NPT X 1/2 H. STR.
11	1	05280	ELBOW, STREET, 3/8 X 90°, BRASS
10	1	105794	FITTING, BULKHEAD, 3/8 NPT, BRASS
9	1	108815	DRAIN MANIFOLD ASSY., SC10, DIR. CON
8	1	14818	NUT, HEX, 1/4-20, S/S
7	1	23118	WASHER, FLAT, 1/4, S/S
6	1	23105	WASHER, SPLIT LOCK, 1/4, S/S
5	1	20302	TERMINAL END SECTION, MARATHON
4	2	20301	TERMINAL SECTION, MARATHON
3	8	101655	WASHER, FLAT #10, S/S
2	8	108123	SCREW, TORX/SLOT 10-32 X 1/2
1	1	105867	PAN, BOTTOM, STEAMCRAFT 10

TOLERANCES (EXCEPT AS NOTED)		CLEVELAND RANGE INC. 1333 East 179th St. Cleveland, Ohio 44110-2574	
DECIMAL ± .030	SCALE 3/16"=1"	DRAWN BY DUTCHMAN	APPROVED BY
ANGULAR ± 1°	TITLE FINAL ASSEMBLY H.L. STEAMCRAFT POWER 10 DIRECT CONNECT		
CK	DATE 03-17-94	DRAWING NO. C - CKD0003	PAGE 3 OF 3 REV. A

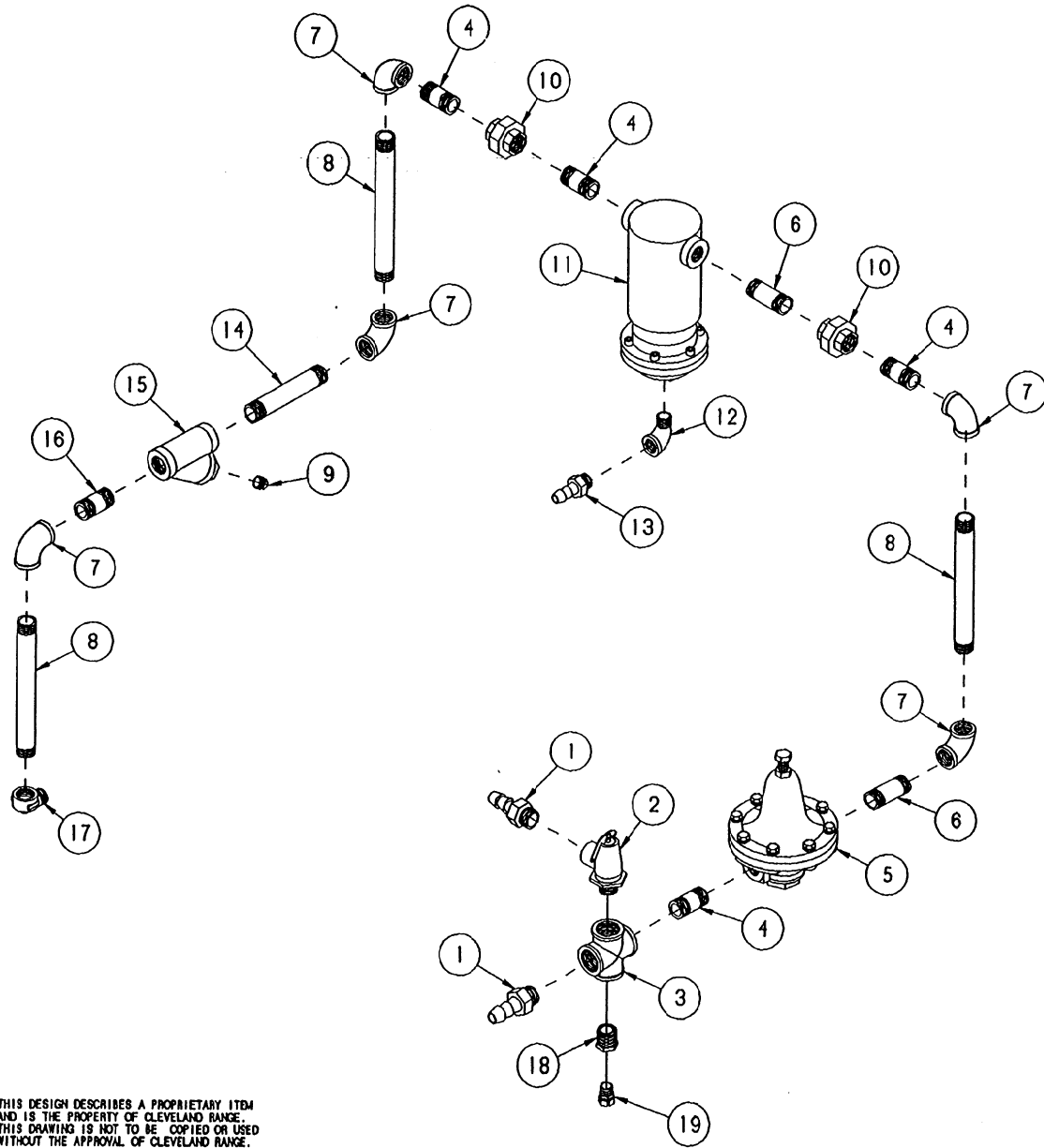

ASSEMBLED VIEW

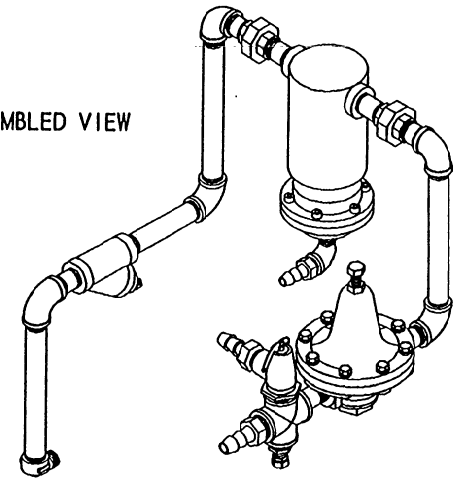

19	1	06199	FITTING, COMPRESSION, 3/8T X 3/8MPT
18	1	02575	BUSHING, REDUCING, 3/4" X 3/8"
17	1	05231	ELBOW, STREET, 3/4", BRASS, FORGED
16	1	14348	NIPPLE, 3/4" X 2.5", BRASS
15	1	19872	STRAINER, Y PIPE FITTING, 3/4"
14	1	14355	NIPPLE, 3/4" X 5", BRASS
13	1	06237	FITTING, HOSE BARB, 1/2H X 1/2MPT
12	1	05252	ELBOW, STREET, 3/4", BLACK
11	1	19020	TRAP, SEPARATOR COMB., #75
10	2	21304	UNION, 3/4", RED BRASS
9	1	16601	PLUG, SQUARE HEAD, 3/8"
8	3	14455	NIPPLE, 3/4" X 0.5", BRASS
7	5	05280	ELBOW, 3/4", BRASS
6	2	14348	NIPPLE, 3/4" X 3", BRASS
5	1	22122	VALVE, PRESSURE REDUCING, 3/4MPT
4	4	14431	NIPPLE, 3/4" X 2", BRASS
3	1	03732	CROSS, 4-WAY, 3/4", BRASS
2	1	22131	VALVE, BOILER SAFETY, 3/4", 15PSI
1	2	06240	FITTING, HOSE BARB, 3/4H X 3/4MPT
ITEM	QTY.	PART NO.	DESCRIPTION

THIS DESIGN DESCRIBES A PROPRIETARY ITEM AND IS THE PROPERTY OF CLEVELAND RANGE. THIS DRAWING IS NOT TO BE COPIED OR USED WITHOUT THE APPROVAL OF CLEVELAND RANGE.

TOLERANCES (EXCEPT AS NOTED)			
CLEVELAND RANGE INC. 1333 East 179th St. Cleveland, Ohio 44110-2574			
DECIMAL ± N/A	SCALE 1/4"=1	DRAWN BY D. DODSON	APPROVED BY
ANGULAR ± N/A	TITLE PLUMBING, STEAMCRAFT 10, DIRECT CONNECT		
CK	DATE 03-17-94	DRAWING NO. C - CKD0002,	REV. -

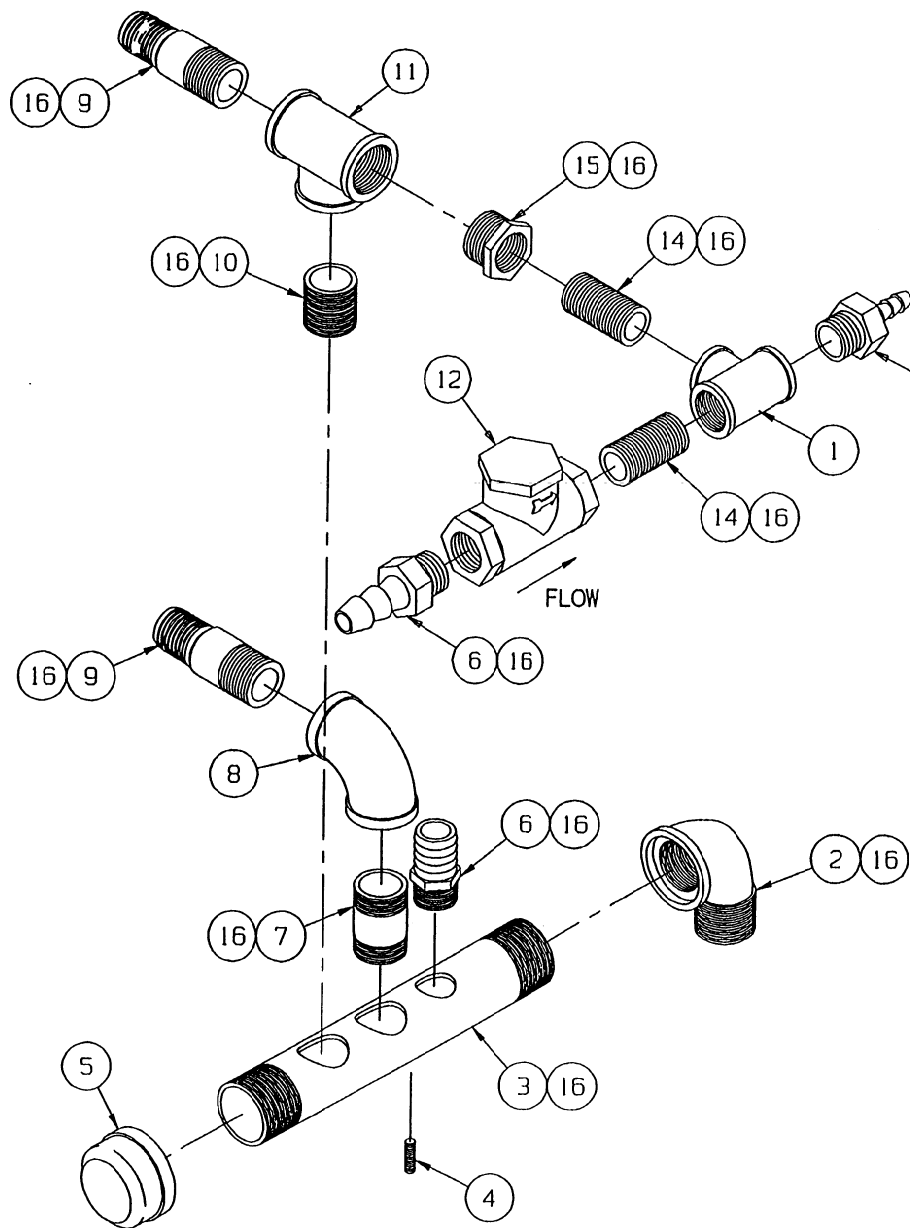

LET.	REVISIONS	DATE	BY
A	REPLACED 100223 WITH 20211, 14323 WITH 14343, 20227 WITH 20205, AND 22149 WITH 22119; ADDED 08240(1), 02598, AND 06235; DELETED 06237(2); SEE EO #C-2610.	6/7/94	DLD

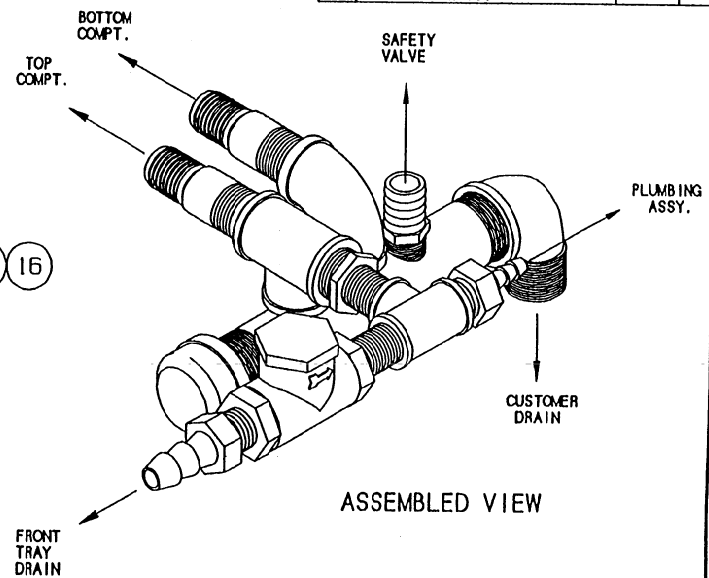

ITEM	QTY.	PART NO.	DESCRIPTION
16	A/R	00934	SEALANT, RECTORSSEAL
▲	15	1	02598 BUSHING, HEX, 1 X 3/4, BLACK
▲	14	2	14343 NIPPLE, 3/4" X CLOSE, BLACK
▲	13	1	06235 FITTING, HOSE BARB, 1/2"H X 3/4"NPT
▲	12	1	22119 VALVE, CHECK, 3/4", BRASS
▲	11	1	20211 TEE, 1", BLACK
▲	10	1	14369 NIPPLE, 1" X CLOSE, BLACK
▲	9	2	14481 FITTING, HOSE BARB, 1"H X 1"NPT
▲	8	1	05285 ELBOW, 1", BLACK
▲	7	1	14373 NIPPLE, 1" X 3", BLACK
▲	6	2	08240 FITTING, HOSE BARB, 3/4"H X 3/4"NPT
▲	5	1	03058 CAP, PIPE, 1-1/2" MALLEABLE IRON
▲	4	1	19917 STUD, WELD 1/4-20 X 7/8, S/S
▲	3	1	13252 MANIFOLD, DRAIN 1-1/2 NPT, BLACK
▲	2	1	05292 ELBOW, STREET, 1-1/2 NPT X 90°, BLACK
▲	1	1	20205 TEE, 3/4", BLACK

TOLERANCES (EXCEPT AS NOTED)			
DECIMAL	SCALE	DRAWN BY	
± N/A	1/2"=1"	D. DODSON	APPROVED BY
ANGULAR	TITLE		
± N/A	DRAIN, MANIFOLD ASSEMBLY STEAMCRAFT 10, DIRECT CONNECT		
DATE	DRAWING NO.	REV.	
CK	2-21-94	C - 106815	A

THIS DESIGN DESCRIBES A PROPRIETARY ITEM AND IS THE PROPERTY OF CLEVELAND RANGE. THIS DRAWING IS NOT TO BE COPIED OR USED WITHOUT THE APPROVAL OF CLEVELAND RANGE.

NOTE: SEE DRAWING 260AHV FOR STUD LOCATION INSTRUCTIONS.