

Statement of Responsibilities

This document is for use by experienced and trained Qualified Cleveland Range, LLC Authorized Service Representatives who are familiar with both the safety procedures, and equipment they service.

Cleveland Range, LLC assumes no liability for any death, injury, equipment damage, or property damage resulting from use of, improper use of, or failure to use the information contained in this document.

Cleveland Range, LLC has made every effort to provide accurate information in this document, but cannot guarantee that this document does not contain unintentional errors and omissions.

The information in this document may be subject to technical and technological changes, revisions, or updates.

Cleveland Range, LLC assumes no liability or responsibility regarding errata, changes, revisions, or updates.

Qualified Cleveland Range, LLC Authorized Service Representatives are obligated to follow industry standard safety procedures, including, but not limited to, OSHA regulations, and disconnect / lock out / tag out procedures for all utilities including steam, and disconnect / lock out / tag out procedures for gas, electric, and steam powered equipment and / or appliances

All utilities (gas, electric, water and steam) should be turned OFF to the equipment and locked out of operation according to OSHA approved practices during any servicing of Cleveland Range equipment

Qualified Cleveland Range, LLC Authorized Service Representatives are obligated to maintain up-to-date knowledge, skills, materials and equipment.

CLEVELAND RANGE
SEQUENCE OF OPERATIONS
Convection Top
Electronic Timer

1. To turn the unit on, depress the red on/off rocker switch at the base.
 - 115 VAC is sent to the red indicator light in the switch
 - 115 VAC is sent to the 24 VAC timer transformer.
 - 24 VAC is sent to the timer.
 - 115 VAC is sent to the timed/manual switch.
2. With the timed/manual switch in the timed position (with time on the timer) or in the manual position.
 - The timer display alternates between “PAUS” and the set time.
 - 115 VAC is sent through the optional door switch.
 - 115 VAC is sent to the condensate solenoid and cold water is sent to the condensate spray nozzle.
 - 115 VAC is sent to the steam solenoid and steam is sent to the cooking cabinet. There the steam is directed around the product and pulled down the drain by the condensate spray.
 - When the cooking compartment reaches 193 degrees internally the thermal switch closes and the timer begins to count down.
3. When the timer counts down in the timed position:
 - 115 VAC is removed from the condensate circuit.
 - 115 VAC is removed from the steam solenoid.
4. The unit is turned off by depressing the red rocker switch.

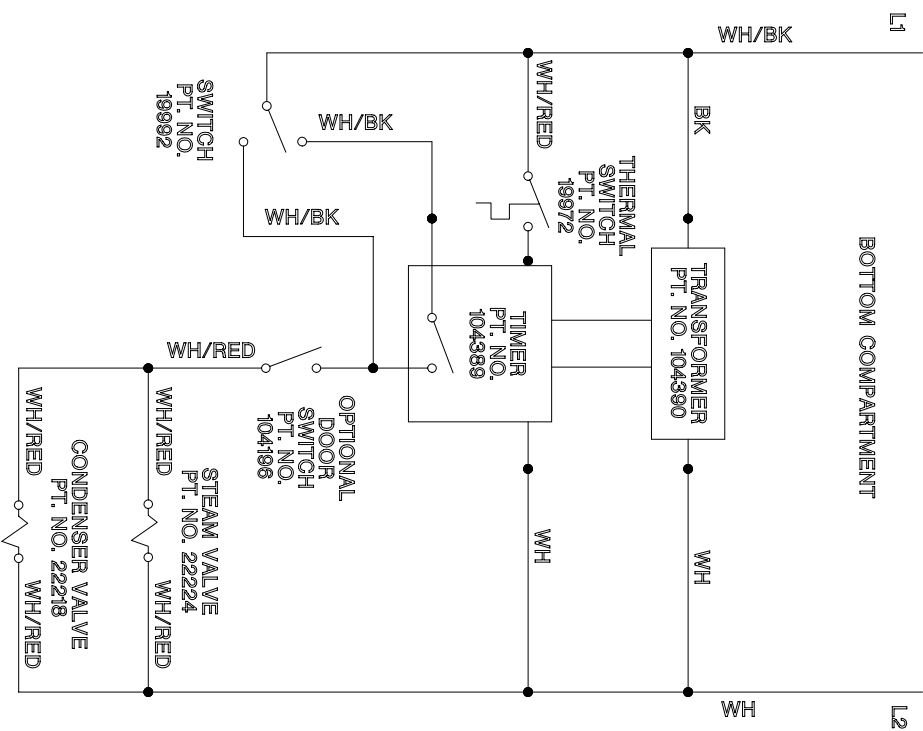
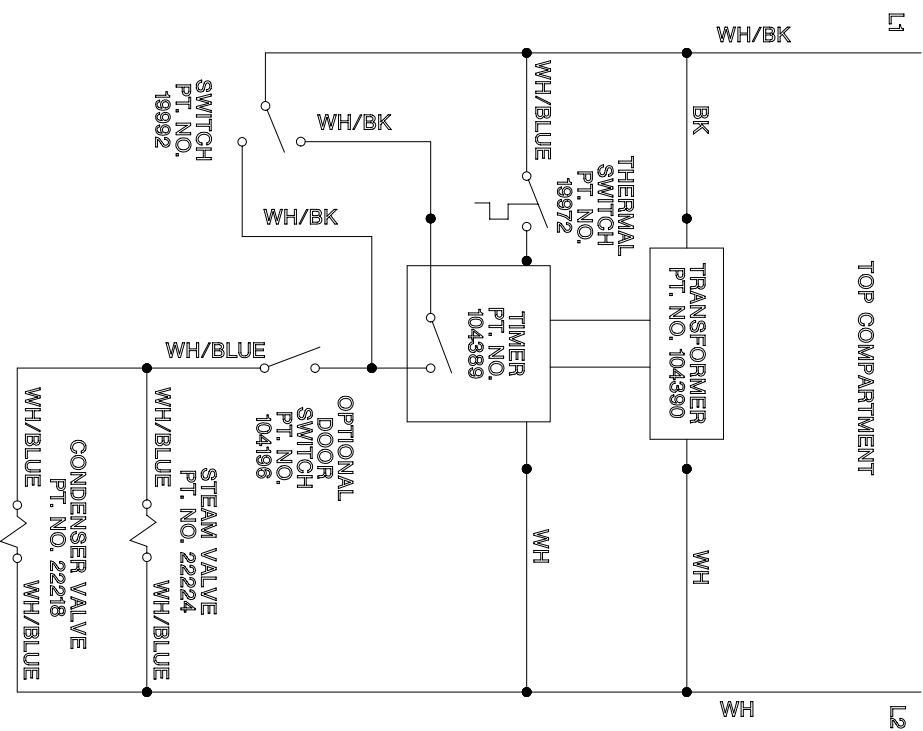

CLEVELAND RANGE
SEQUENCE OF OPERATIONS
Convection Top
Mechanical Timer

1. To turn the unit on, depress the red on/off rocker switch at the base.
 - 115 VAC is sent to the red indicator light in the switch
 - 115 VAC is sent to the timed/manual switch.

2. With the timed/manual switch in the timed position (with time on the timer) or in the manual position.
 - 115 VAC is sent through the optional door switch.
 - 115 VAC is sent to the condensate solenoid and cold water is sent to the condensate spray nozzle.
 - 115 VAC is sent to the steam solenoid and steam is sent to the cooking cabinet. There the steam is directed around the product and pulled down the drain by the condensate spray.

3. When the timer counts down in the timed position:
 - 115 VAC is removed from the condensate circuit.
 - 115 VAC is removed from the steam solenoid.
 - 115 VAC is sent to the 3-second timer
 - 115 VAC is sent from the 3-second timer to the buzzer for 3 seconds.

4. The unit is turned off by depressing the red rocker switch.

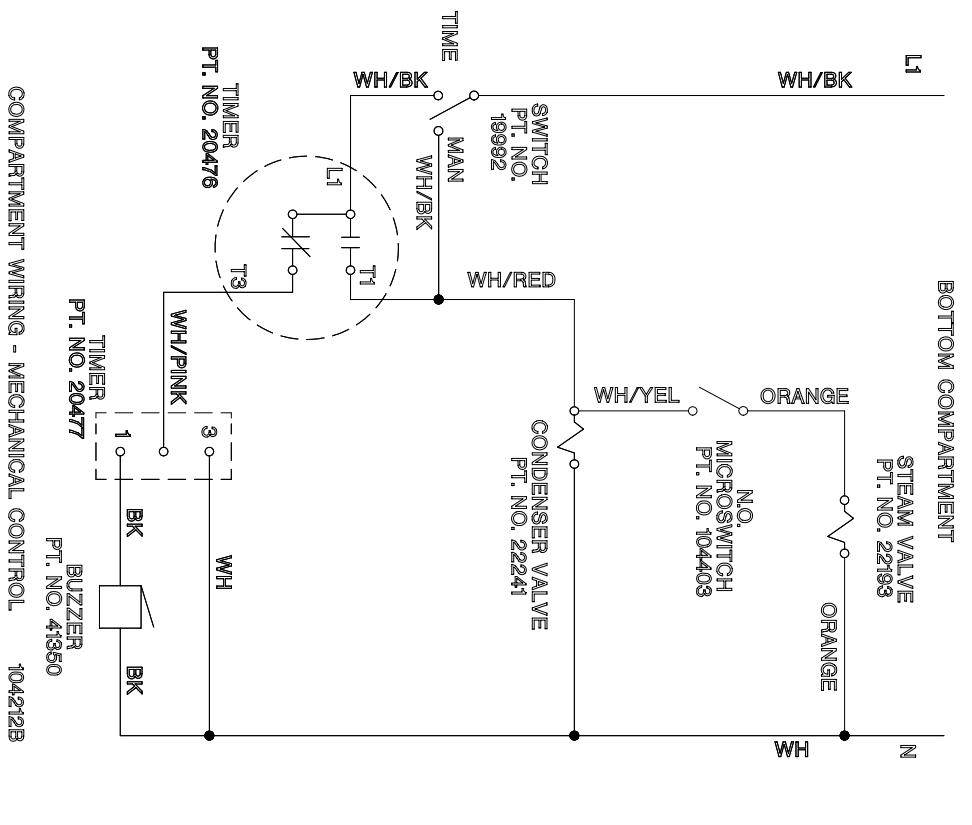
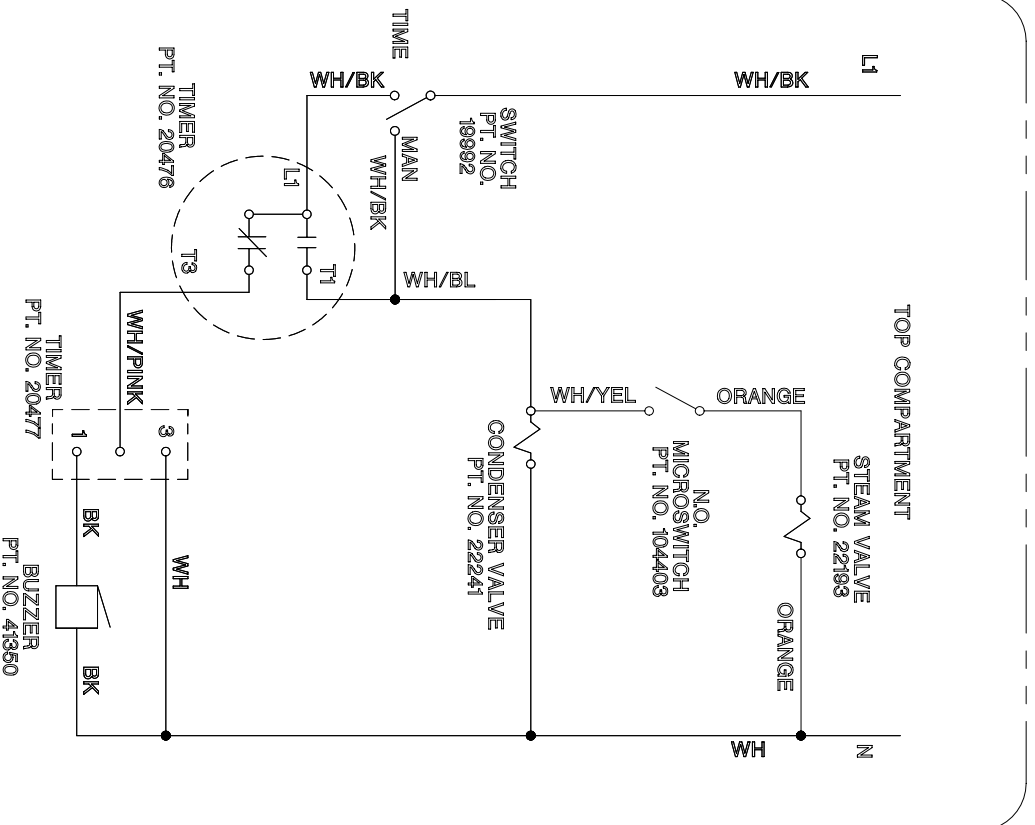

Cleveland Classic Series®

TWO COMPARTMENT-PRESSURELESS
200M BTU GAS FIRED STEAM GENERATOR
24" WIDE CABINET BASE DESIGN
with NickelGard

MODEL: 24-CGM-200

ITEM NUMBER _____

JOB NAME / NUMBER _____

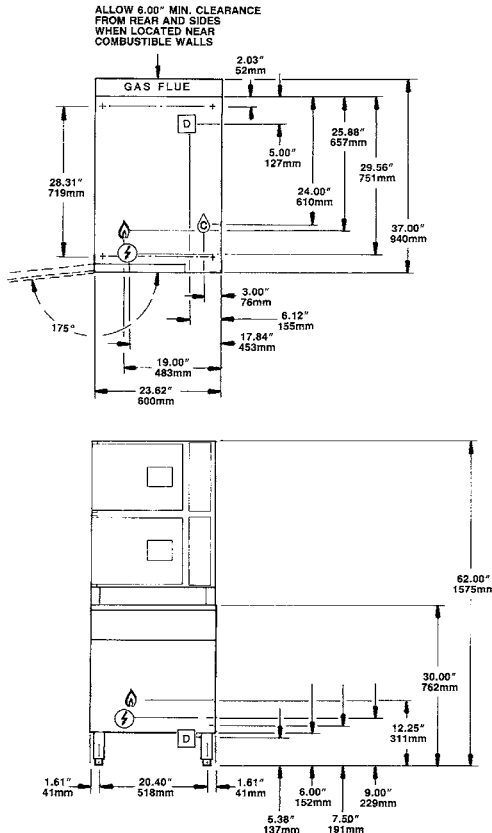



NOTE: When ordering optional reverse door openings: Control Panel, door openings, cooking compartments and clearances are opposite that shown.





SHORT FORM SPECIFICATION

Shall be Two Compartments, CLEVELAND Convection Steamer, Model 24-CGM-200, Gas-fired Steam Generator, NickelGard, 200M BTU. Solid State Controls operate timing, water level and safety functions. Steam Generator with Automatic Water Fill on start-up, Automatic Blowdown with additional Manual Drain Valve and Electronic Spark Ignition. For each cooking compartment: 60 minute Mechanical Timer, Manual Operation Mode and Cold Water Condenser. Type 304 Stainless Steel cooking compartment.

GAS 		ELECTRIC 
NATURAL	PROPANE	115V - 1 PH
3/4" IPS for 220,000 BTU or less. 1.00" IPS for 250,000 BTU or more.	3/4" IPS for 220,000 BTU or less. 1.00" IPS for 250,000 BTU or more.	25 watts per compartment.
Supply pressure: 4.00" W.C. minimum 14.00" W.C. maximum	Supply pressure: 12.00" W.C. minimum 14.00" W.C. maximum	50 watts for Steam Generator Control.
Manufacturer must be notified if unit will be used above 2,000 ft. altitude.		

Cleveland Range reserves right of design improvements or modifications, as warranted.

WATER 	DRAINAGE 	CLEARANCE
3/4" IPS Cold Water Inlet 35 psi minimum 60 psi maximum	The Floor Drain must be located outside the confines of the equipment base. 1 1/2" IPS common drain. Do not connect other units to this drain. Do not use PVC pipe for drain.	RIGHT = 6.00" (12" if adjoining wall or equipment is over 30.00" high) LEFT = 6.00" REAR = 6.00"

WATER QUALITY REQUIREMENT

The recommended minimum water quality standards whether untreated or pre-treated, based upon 10 hours of use per day, and a Daily Blowdown, are as follows:

TOTAL DISSOLVED SOLIDS	less than	60 parts per million
TOTAL ALKALINITY	less than	20 parts per million
SILICA	less than	13 parts per million
pH FACTOR	greater than	7.5

Consult a local water treatment specialist for an on site water analysis for recommendations concerning steam generator feed water treatment (if required), in order to remove or reduce harmful concentrations of minerals. The use of highly mineralized water will mean that more frequent servicing of the steam generator will be necessary. The fact that a water supply is potable is not proof that it will be suitable for the generator.

CLEVELAND RANGE
SEQUENCE OF OPERATIONS
Gas Boiler Base

1. To turn the unit on, depress the red on/off rocker switch.
 - 115 VAC is sent to the terminal block in control box.
 - 115 VAC is sent to normally open blowdown valve closing it.
 - 115 VAC is sent to L1 and L2 of the water level board.

2. With the water level board energized and no water in the boiler
 - 115 VAC is sent from the IND terminal to the low water indicator light.
 - 115 VAC is sent from the WF terminal to the fill solenoid.
 - The fill solenoid opens and the boiler fills.
 - The water fills to the low probe shorting it to ground
 - 115 VAC is removed from the IND terminal and the low water indicator light is de-energized.
 - 115 VAC is sent from the HTR terminal through the normally closed contact of the high-pressure switch to the amber reset switch,
 - 115 VAC is sent through the normally closed R1B contact to energize the amber light.
 - If the low probe is not grounded for 20 seconds, 115 VAC is removed from HTR and sent back to IND energizing the low water indicator light.

3. When the momentary amber switch is depressed 115 VAC is sent to the R1 relay closing it.
 - The normally closed R1B contacts open de-energizing the amber light.
 - The relay latches itself through contacts 3 and 5 with a jumper to the coil.
 - If either the high-pressure switch opens or the low probe circuit on the water level board opens, then the latch circuit opens.
 - When the water level or pressure returns to a safe condition the amber light will energize and the process may begin again.
 - The R1B relay contacts close sending 115 VAC through the normally closed operating pressure switch to the 24 VAC transformer.
 - 24 VAC is sent to the ignition module.

4. With 24 VAC to the ignition module 24 VAC is sent to the gas valve.
 - The gas valve is energized.
 - The gas valve opens to the initial stage and sends gas to the burner.
 - The initial stage for a 200,000 BTU boiler base natural gas is 1.25" W.C.
 - The initial stage for a 300,000 BTU Boiler base natural gas is .75" W.C.
 - The initial stage for L.P. boiler base is 2.5" W.C.
 - A spark is generated at the igniter.
 - The gas is ignited and the flame rectifies the AC current.
 - The ignition module reads 1.5 micro amps DC current through the ground wire.

- If the module does not read 1.5 micro amps DC in 4 seconds it will lock out.
 - When the ignition module locks out 24 VAC is sent to the buzzer from the alarm terminal on the module.
 - The gas valve continues to open to 3.5" water column in 6-8 seconds for natural gas boiler base and 10" W.C. for L.P.
5. The water in the boiler is heated to steam.
 - As steam is generated and pressure builds the air is pushed out through the steamtrap.
 - When steam goes through the steam trap and heats it to 192 degrees it closes.
 6. Pressure builds in the boiler to the set point (8 PSI).
 - The operating pressure switch opens and the heat circuit is de-energized.
 - When the pressure drops below the set point the heat circuit is energized and the heat process begins again.
 7. Water continues to fill until the high probe is grounded.
 - When the high probe is grounded the WF terminal on the water level board is de-energized.
 - The fill solenoid closes until the high probe is ungrounded for 5 seconds.
 - If the water level drops below the high probe for more than 5 seconds the WF terminal is energized and the water fill circuit begins again.
 8. When the unit is turned off, by depressing the red rocker switch,
 - 115 VAC is removed from the heat circuit.
 - 115 VAC is removed from the drain circuit and the normally open drain valve opens allowing the unit to drain.
 - 115 VAC is sent to the 3-minute timer.
 - The three-minute timer will energize the fill solenoid for 3 minutes while the steamer drains.

CLEVELAND RANGE
SEQUENCE OF OPERATIONS
Gas Boiler Base
With Secondary Low Water Cut Off Switch

1. To turn the unit on, depress the red on/off rocker switch.
 - 115 VAC is sent to the terminal block in control box.
 - 115 VAC is sent to normally open blowdown valve closing it.
 - 115 VAC is sent to L1 and L2 of the water level board.
 - 115 VAC is sent to the open contacts of the low water cut-off switch.
 - 115 VAC is sent through the normally closed contacts of the R2 relay to the low water indicator light.

2. With the water level board energized and no water in the boiler
 - 115 VAC is sent from the IND terminal to the normally open contacts of R2A.
 - 115 VAC is sent from the WF terminal to the fill solenoid.
 - The fill solenoid opens and the boiler fills.
 - The rising water raises the float on the low water cut-off switch closing it.
 - R2 relay is energized.
 - The normally closed contacts R2A open de-energizing the low water indicator light.
 - The normally open contacts of R2A close energizing the low water indicator light.
 - The water fills to the low probe shorting it to ground
 - 115 VAC is removed from the IND terminal and the low water indicator light is de-energized.
 - If the low water cut off float switch opens the low water indicator light re-energizes.
 - 115 VAC is sent from the HTR terminal to the normally open contacts of R2B.
 - With water in the unit and the R2 relay energized, 115 VAC is sent through the normally closed contact of the high-pressure switch to the amber reset switch,
 - 115 VAC is sent through the normally closed R1B contact to energize the amber light.

3. When the momentary amber switch is depressed 115 VAC is sent to the R1 relay closing it.
 - The normally closed R1B contacts open de-energizing the amber light.
 - The relay latches itself through contacts 3 and 5 with a jumper to the coil.
 - If either the high-pressure switch opens, the secondary low water cut off switch opens, or the low probe circuit on the water level board opens, then the latch circuit opens.
 - When the water level or pressure returns to a safe condition the amber light will energize and the process may begin again.
 - The R1B relay contacts close sending power through the normally closed operating pressure switch to the 24 VAC transformer.
 - 24 VAC is sent to the ignition module.

4. With 24 VAC to the ignition module, 24 VAC is sent to the gas valve.
 - The gas valve is energized.
 - The gas valve opens to the initial stage sending gas to the burner.
 - The initial stage Natural gas pressure for the 200 BTU boiler base is 1.2" W.C.
 - The initial stage Natural gas pressure for the 300 BTU boiler base is .75"W.C.
 - The initial stage LP gas pressure is 2.5" W.C. for both boiler bases.
 - A spark is generated at the igniter.
 - The gas is ignited and the flame rectifies the AC current.
 - The ignition module reads 1.5 micro amps DC current through the ground wire.
 - If the module does not read 1.5 micro amps DC in 4 seconds it will lock out.
 - When the ignition module locks out 24 VAC is sent to the buzzer from the alarm terminal on the module.
 - The gas valve continues to open to the second stage in 6-8 seconds.
 - The second stage natural gas pressure is 3.5" W.C.
 - The second stage LP gas pressure is 11" W.C.
5. The water in the boiler is heated to steam.
 - As steam is generated and pressure builds the air is pushed out through the steamtrap.
 - When steam goes through the steam trap and heats it to 192 degrees it closes.
6. Pressure builds in the boiler to the set point.
 - The operating pressure switch opens and the heat circuit is de-energized.
 - When the pressure drops below the set point the heat circuit is energized and the heat process begins again.
7. Water continues to fill until the high probe is grounded.
 - When the high probe is grounded the WF terminal on the water level board is de-energized.
 - The fill solenoid closes until the high probe is ungrounded for 05 seconds.
 - If the water level drops below the high probe for more than 05 seconds the WF terminal is energized and the water fill circuit begins again.
8. When the unit is turned off, by depressing the red rocker switch, 115 VAC is sent to the 3-minute timer.
 - The three-minute timer will energize the fill solenoid for 3 minutes while the steamer drains.
 - 115 VAC is removed from all other circuits.
 - The red light in the power switch is de-energized.

115 VAC



BLK FROM CUSTOMER CONNECTION WHT/GRA WHT

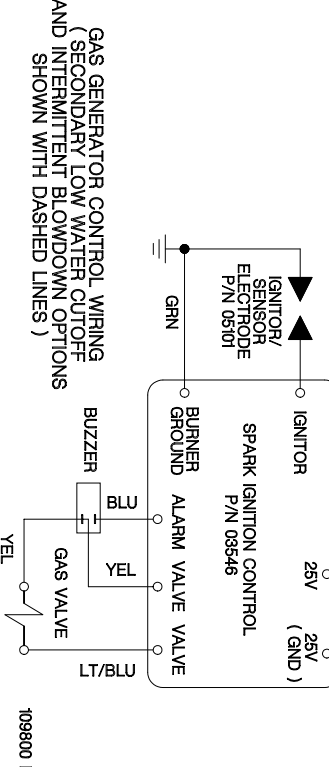
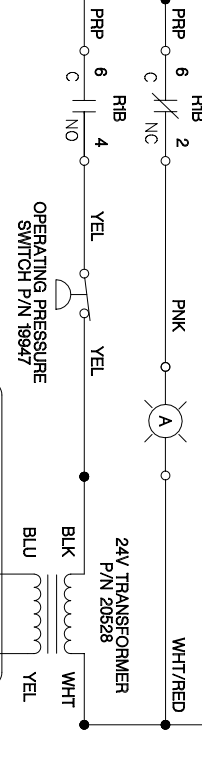
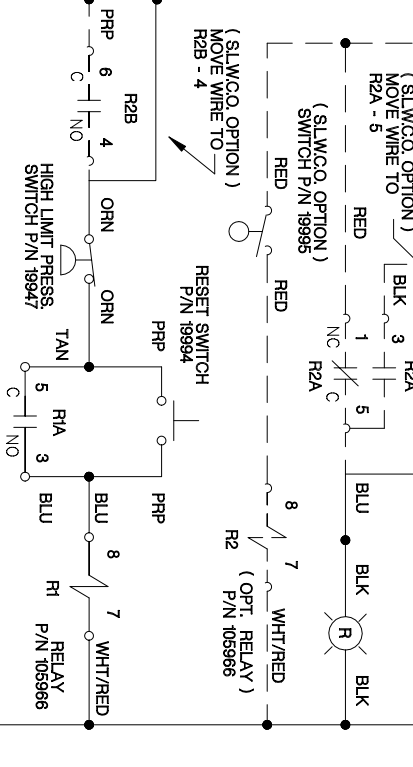
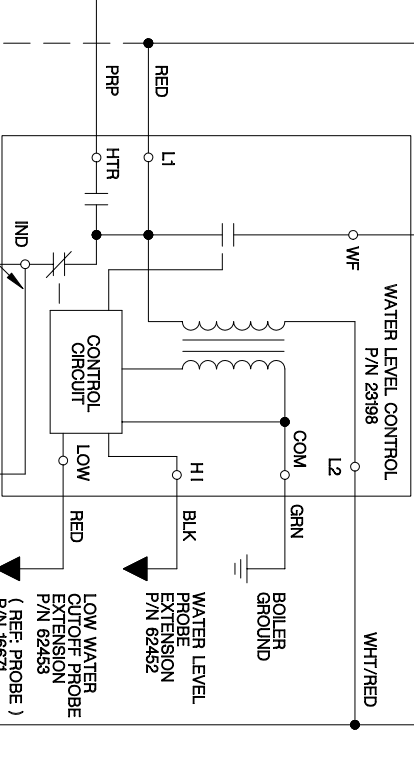
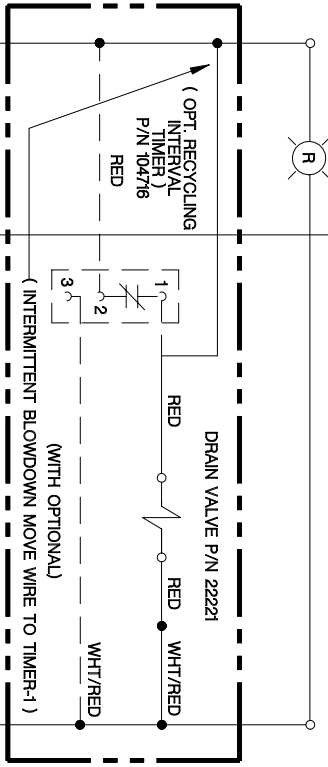
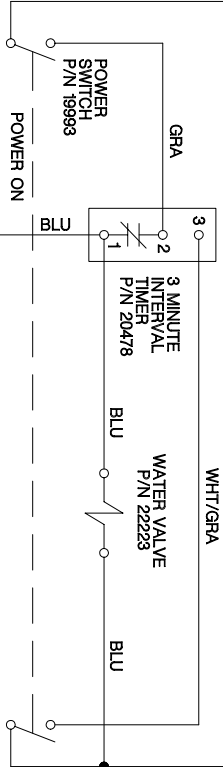

STANDARD UNIT BOILER BASE

AS OF 8-27-01

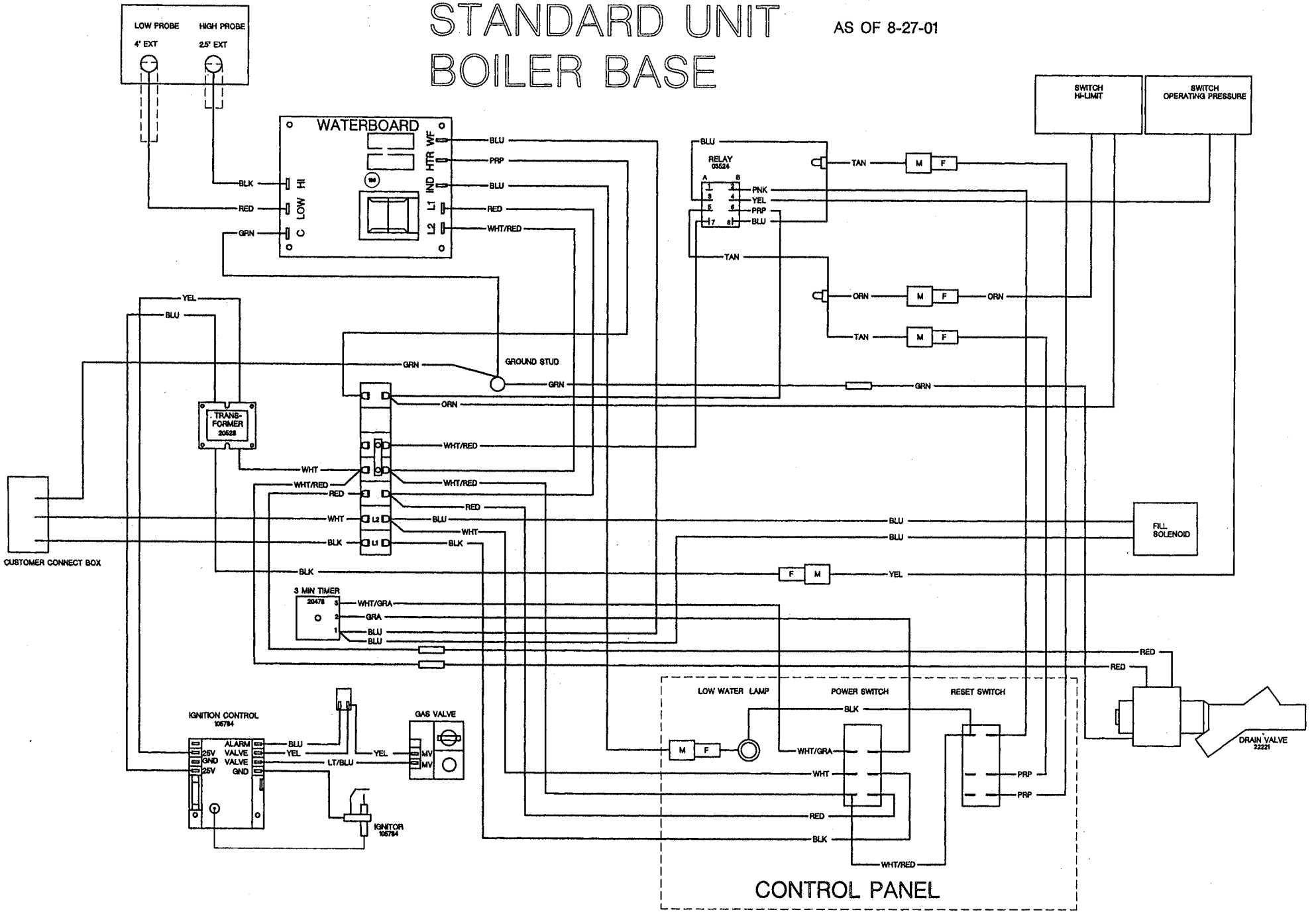

BOILER BASE UNIT WITH S.L.W.C.O.

AS OF 8-27-01

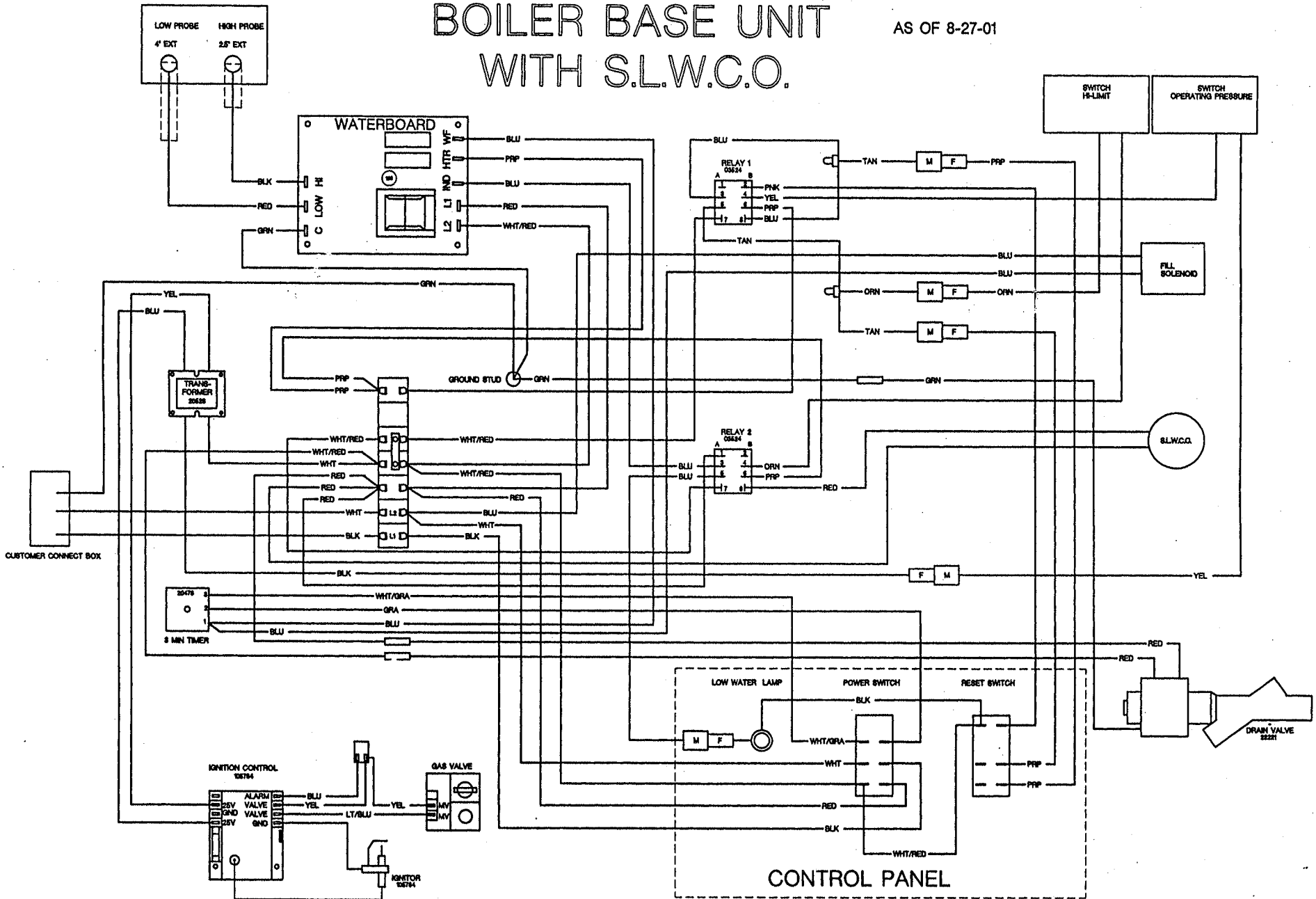

**PROBLEM:
Gas Boiler won't
build pressure**

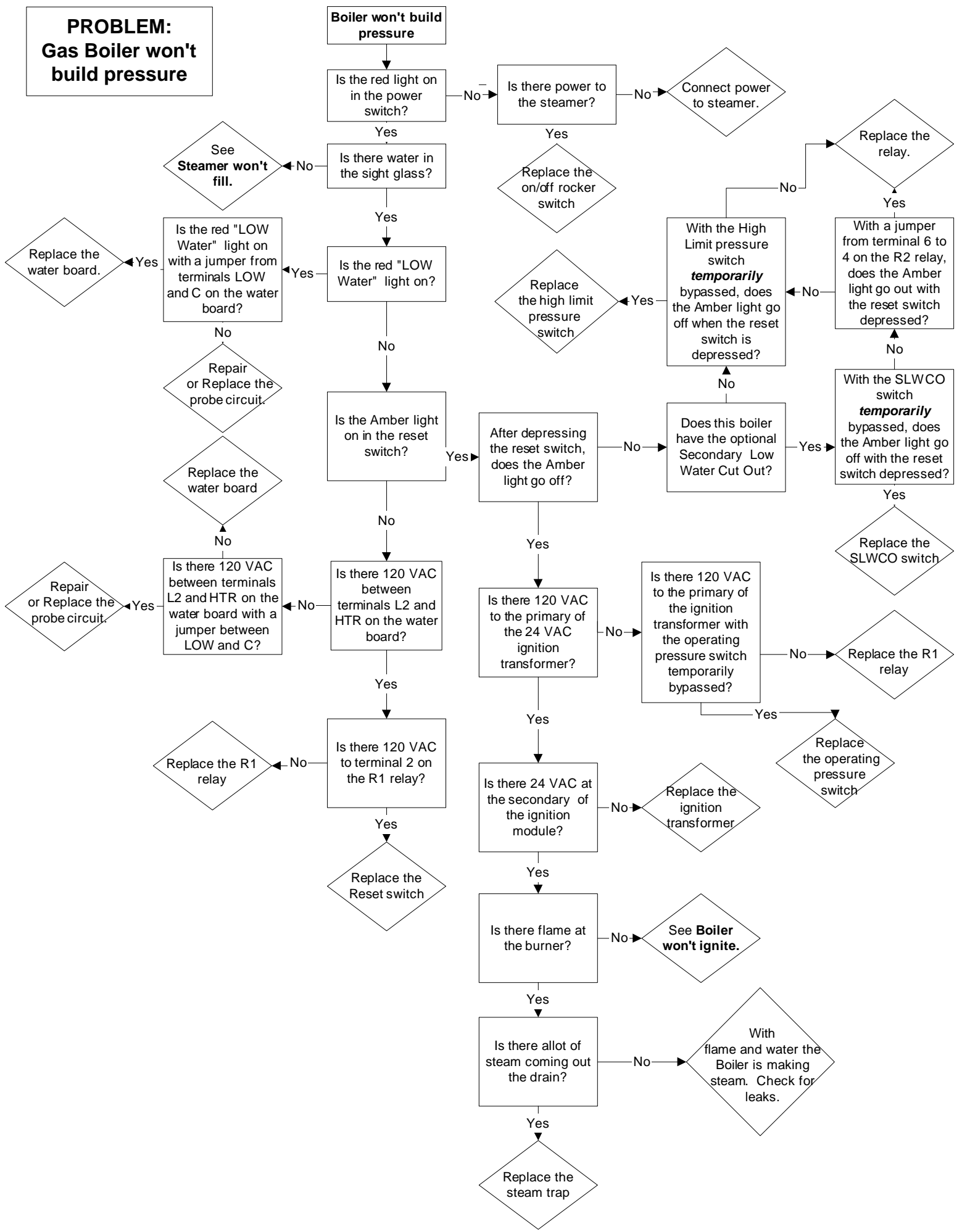

**PROBLEM:
Gas boiler
won't fill**

Boiler won't fill.

Yes

Is there power to the steamer?

No

Supply power to the steamer.

Yes

Is there water to the steamer?

No

Supply cold water to the steamer.

Yes

Is there 120 VAC between the L1 and L2 on the water board?

No

Replace the on/off rocker switch .

Yes

Is there 120 VAC between L2 and WF on the water board?

No

Remove the wire from the HI terminal on the water board. Is there 120 VAC between L2 and WF?

No

Replace the water board

Yes

Is there 120 VAC across the coil of the fill solenoid?

Yes

Is there debris on the HI probe extension?

No

Replace the wire to the Hi probe.

Replace the wiring to the fill solenoid.

No

Yes

Is water leaving the fill solenoid?

No

Replace the fill solenoid

Clean or replace the probes extension.

Yes

Yes

Is there 120 VAC across the coil of the drain valve?

Yes

Is water draining from the generator?

No

If water is leaving the fill solenoid and not draining from the generator where is it going? check for leaks..

Does the steamer have the optional intermittent blowdown timer?

No

No

Replace wiring to drain solenoid.

Yes

Is there 120 VAC between terminals 2&3 on the timer?

No

Replace the wiring to the intermittent blowdown timer .

Yes

Replace the intermittent blowdown timer.

Yes

Replace the drain valve.

**PROBLEM:
Gas boiler
won't ignite**

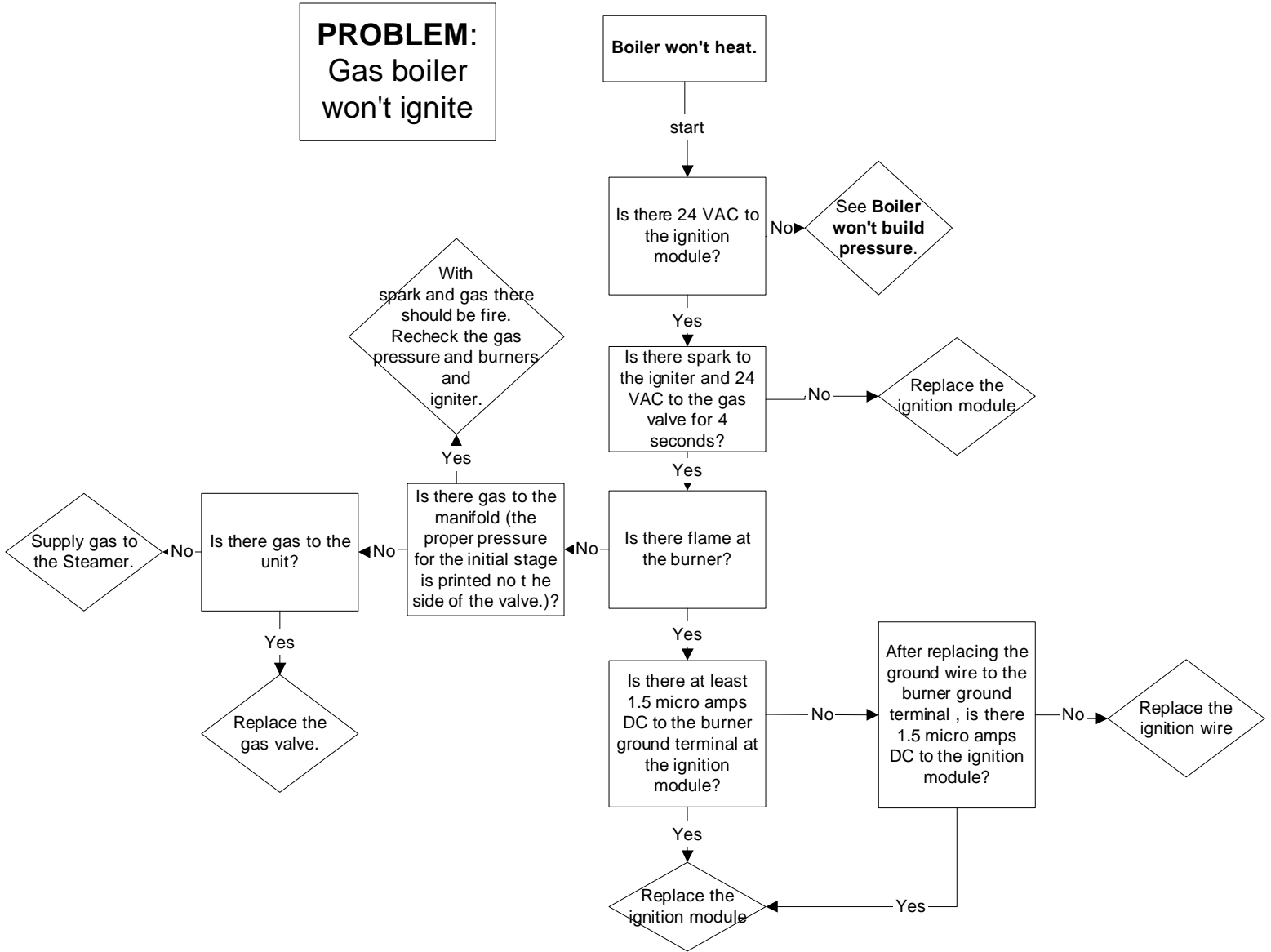

PROBLEM: Gas Boiler Overfills

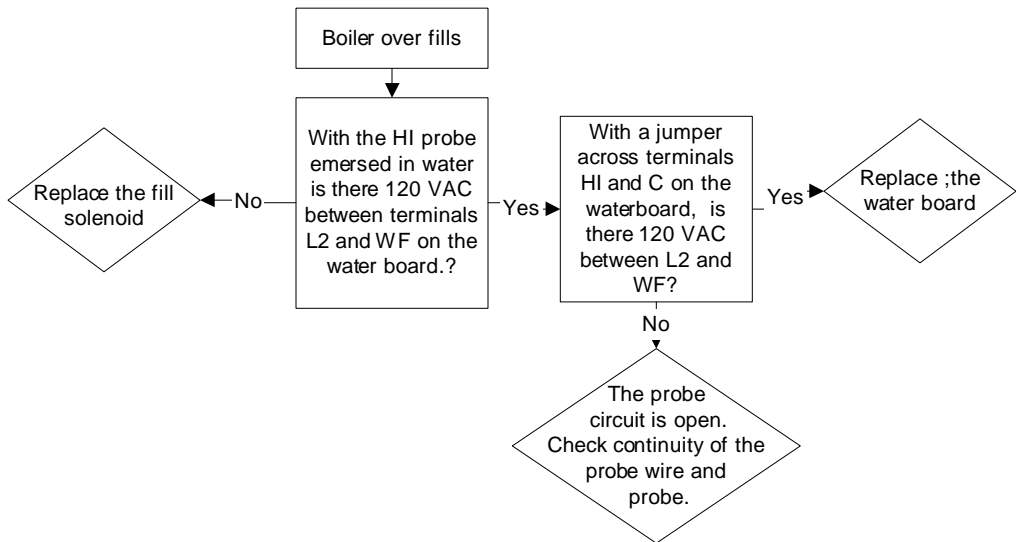

**PROBLEM:
Gas Boiler Over
Pressurizes
(15# Safety
valve opens)**

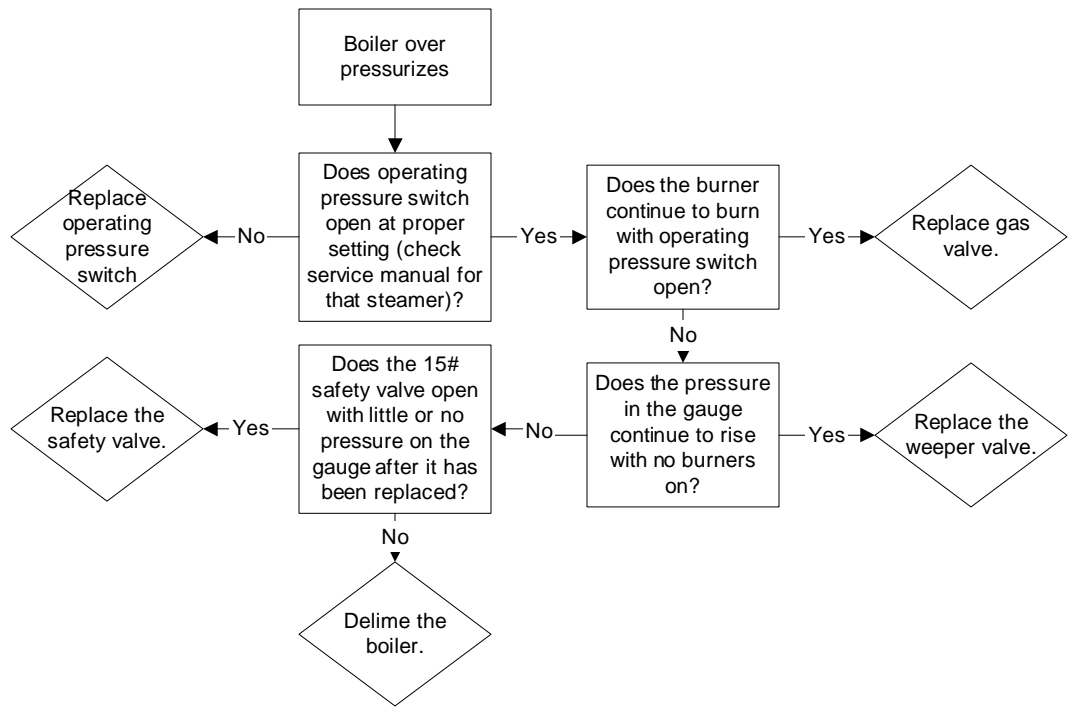

PROBLEM: Gas Boiler Stops Producing Steam

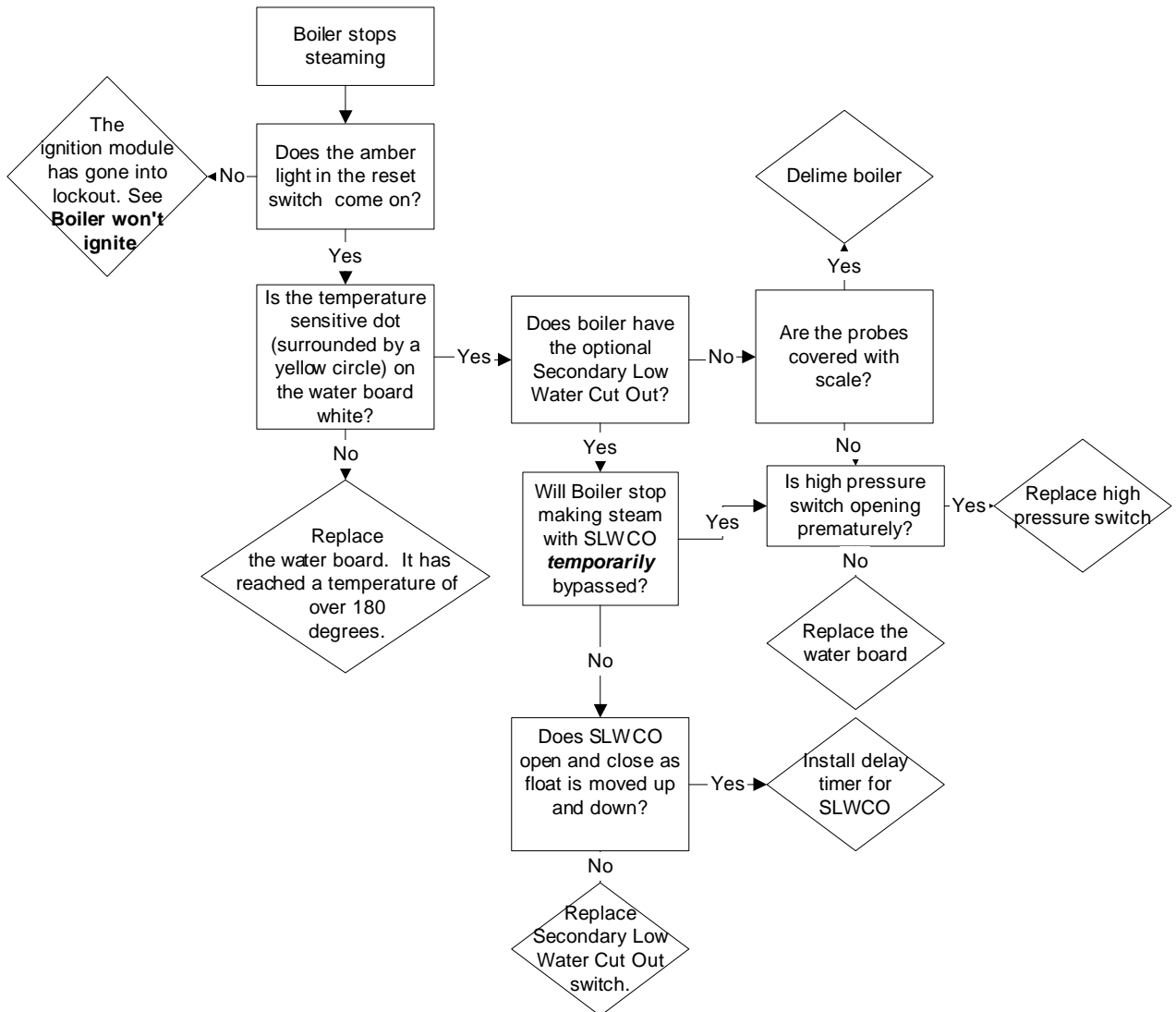



DESCALE PROCEDURE FOR
TWO & THREE PROBE GENERATOR BASE STEAMERS

STEP BY STEP PROCEDURE

IMPORTANT WARNING: BEFORE REMOVING THE HAND HOLE PLATE TO DESCALE ANY STEAM GENERATOR, MAKE SURE THERE IS NO WATER OR PRESSURE BUILT UP IN THE GENERATOR. CHECK THE OUTER SURFACE OF THE GENERATOR TO MAKE SURE IT IS COLD. TURN THE YELLOW HANDLE ON THE MANUAL FILL VALVE 90 DEGREES TO THE BODY TO PREVENT ANY WATER FROM ENTERING THE UNIT. THIS LIQUID DESCALER IS DESIGNED TO BE USED WITH NO HEAT APPLIED TO THE GENERATOR.

STEP #1

Before opening the hand hole plate in the generator make sure the red power switch is in the off position. Open the electric circuit box in front of the generator and look for two black square solid state timers mounted on the side. If there are two solid state timers in the box, this unit has a TDS blowdown. The timer mounted on top is a one-second timer. Remove the white wire from the terminal marked number 3 on the TDS timer to prevent the purge from coming on.

To open the hand hole plate, loosen and remove the nut and bar across the generator opening. Place the end of a two x four on the hand hole plate. Rap the end of the wood with a hammer in various places until the plate and gasket fall inside the generator.

Remove any scale build-up that can be taken out by hand or with a small vacuum cleaner. **IF THE GENERATOR HAS PREVIOUSLY BEEN REPLACED WITH A NICKEL PLATED ONE, DO NOT SCRAPE OR SCRATCH THE SURFACE.** Assess the scale build-up above the water level on the tubes and the top to determine the number of descalings that will be needed.

Use 2 gallons of liquid cleaner regardless of the size of the boiler. If there is a heavy build-up of scale (1/4" or more) on the upper tubes (above the water level) and across the top of the generator, it will have to be descaled twice.

After removing the scale and determining the number of descalings needed, replace the hand hole plate with the old gasket still on the plate.

STEP #2

Remove the safety relief valve from the front of the generator. This will be the port of entry for the liquid

descaling agent. **REMEMBER TO MOVE THE YELLOW HANDLE ON THE WATER FILL VALVE TO ALIGN WITH THE VALVE BODY.** Before applying the descaler, turn on the power switch to close the drain valve. This will also energize the fill valve.

STEP #3

Using a funnel and tubing, pour the liquid descaler into the generator through the port the safety relief valve was removed from.

STEP #4

After the descaling agent has been introduced into the generator, replace the safety relief valve.

1. Place the upper compartment timer switch in the manual position. As the generator is filling with water, this will allow any air in the top to escape.
2. To completely fill the generator with water, bypass the water level probe:
 - a. Remove the black wire at the terminal marked HI on the water level control board that connects to the water level probe.
 - b. When the water begins to enter the upper cooking compartment, CAREFULLY replace the black wire on the water level control. This will turn the water off.

STEP #5

DO NOT PRESS THE AMBER STEAM SWITCH. THIS CHEMICAL WORKS BEST WHEN COLD.

STEP #6

Wait 1-2 hours to allow for descaling of the generator. Drain the generator by turning off the red POWER switch. The drain and fresh water solenoid valves will open for three minutes allowing the generator to flush out. After draining, fill the generator with fresh water and repeat the flush process by turning off the power switch.

STEP #7

After the generator has been rinsed out, remove the hand hole plate and gasket as explained in STEP #1. Observe the edges and surfaces of the hand hole and the plate for excessive wear-and corrosion. Replace the used hand hole plate gasket with a new one and install new anodes.

For the anodes to work properly, the hanger must be firmly connected to the support rod. Make sure no scale or debris is between the support and the hanger. It must be a metal to metal connection.

Do not use a gasket sealing material on the hand hole plate gasket. When tightening the nut on the bar, make sure that at least 1/16" of gasket material is showing all of the way around the inside of the hand hole plate.

Reinstall the wire removed from the purge timer in the electric box.

STEP #8

Bring the steamer up to pressure by pressing the red power switch to fill the generator and then the amber switch when the light comes on. After twenty (20) minutes the generator should have steam in it. Check for steam leaks around the hand hole. If any leaks are found repeat the process for replacing the gasket.

DESCALING PROCEDURE

for

200/300KBTU BOILER BASES

PRELIMINARY PROCEDURE

- 1) Start with the unit turned off & completely cool.
The boiler will drain in approximately 3 minutes.
- 2) Open the door at the base of the unit.
- 3) Remove the handhole plate & gasket. Discard old gasket.
- 4) Inspect the boiler for scale build-up. Remove any loose scale within reach of the handhole plate area.
- 5) Proceed to correct boiler instructions listed below.
- 6) For descale piping parts list, see P/N 107142 Rev "F".

1333 East 179th Street
Cleveland, Ohio 44110

Phone: (216) 481- 4900
Fax: (216) 481- 3782



Part No. 260ALK - F 4/03

GAS BOILER, ORIGINAL VERSION

- 1) For piping setup, see P/N 260ALK Sht 4 of 7.
- 2) Install handhole plate with descaler ports (Item 1) & new gasket (Item 12).
- 3) After descaler handhole plate has been installed, attach the 2.500 inch nipples with attached unions to the inlet & outlet ports.
- 4) Remove cal code switch (p/n 19995) from the boiler base & clean the shaft under the float.
- 5) Connect the 1/2 inch hose with the attached union to the bottom 2.500 inch nipple.
- 6) Connect the 3/4 inch hose with the attached union to the top 2.500 inch nipple.

GAS BOILER, FIELD REPLACEMENT VERSION

- 1) For piping setup, see P/N 260ALK Sht 5 of 7.
- 2) Install handhole plate with new gasket.
- 3) Remove Cal Code plate (p/n 19995) from the boiler base.
- 4) Install plate (Item 18) in place of Cal Code switch for descaling procedure.
- 5) When the boiler is descaling, clean Cal Code switch (p/n 19995, if applicable) once removed. Also, clean the shaft under the float.
- 6) Remove plug from tee & install descale plumbing assembly (Items 2, 3, 4, 5, 14, 15, & 18) on discharge side in male run tee located underneath the safety valve.
- 7) Install descale plumbing assembly (pump side) in Cal Code plate. Connect plumbing assembly to item 19.

GAS BOILER, CURRENT PRODUCTION RELEASE

- 1) For piping setup, see P/N 260ALK Sht 6 of 7. Install handhole plate with new gasket.
- 2) Remove plug from LWCO plate (if so equipped) & from the male run tee underneath the safety valve.
- 3) Install descale plumbing assembly (on left side) in male run tee, connected to the safety valve.
- 4) Install descale plumbing assembly (with pump) in drain port.
- 5) If applicable, remove LWCO switch (p/n 19995) from boiler base.
- 6) If applicable when the boiler is descaling, clean LWCO switch (p/n 19995) once removed. Also, clean the shaft under the float.

DESCALING INSTRUCTIONS

- 1) The manual blowdown drain valve must be closed.
(if so equipped), the manual 3/4 inch ball valve is located at the lower right front of the boiler face.
- 2) The valve handle should be perpendicular to the valve.
- 3) Fill the 5-gallon bucket with 2 gallons of descaler & 3 gallons of water.
- 4) Turn the unit on.
- 5) Turn on the pump for the descaler & open the inlet valve (Item 8) to the boiler. Let the boiler fill with descaler to just above the top of the sight glass. Before opening the exit valve, make sure the exit line is in the bucket with the pump.
Note: The amber light reset switch on the console will turn on.
DO NOT PRESS THIS SWITCH
- 6) It is recommended that the descaler level in the boiler be at the top of the boiler. This can be accomplished by controlling the flow with the ball valves.
- 7) Let the pump operate for 1 hour. Once the dissolve becomes neutral, the PH indicator will turn purple. The dissolve becomes ineffective.
Note: Liquid level in the descaler bucket should not drop below the pump. Add water if necessary.
- 8) After 1 hour, turn off the pump & close the inlet ball valve. Open the manual drain and then turn the main switch to off & let drain.
- 9) Flush the boiler with water once all of the descaler has been drained.
- 10) Close the manual blowdown drain valve (if so equipped).
- 11) Turn the unit on to fill with water.
 - a) Fill the 5-gallon bucket with water,
 - b) 2 cups of baking soda may be added to the waterWhen the water level reaches the middle of the sight glass, open the inlet valve & turn on the pump. Make sure that the outlet valve from the handhole plate is closed.
- 12) Let the water level rise above the top of the sight glass. After 10 minutes, open the manual drain valve (if so equipped) & turn the unit off.
Note: If the unit does not have a manual drain valve, then turn the main switch to off.
- 13) Continue flushing with water for 3 minutes. Once flushing is complete, the unit is descaled. Remove the descaling handhole plate and replace with the original where necessary.
- 14) Remove the pump assembly and install plugs where necessary.

GAS BOILER/ELECTRIC BOILER ORIGINAL VERSION (GAS SHOWN)

ENLARGED VIEW A
SHOWING KIT ASSEMBLED
TO FRONT OF GENERATOR

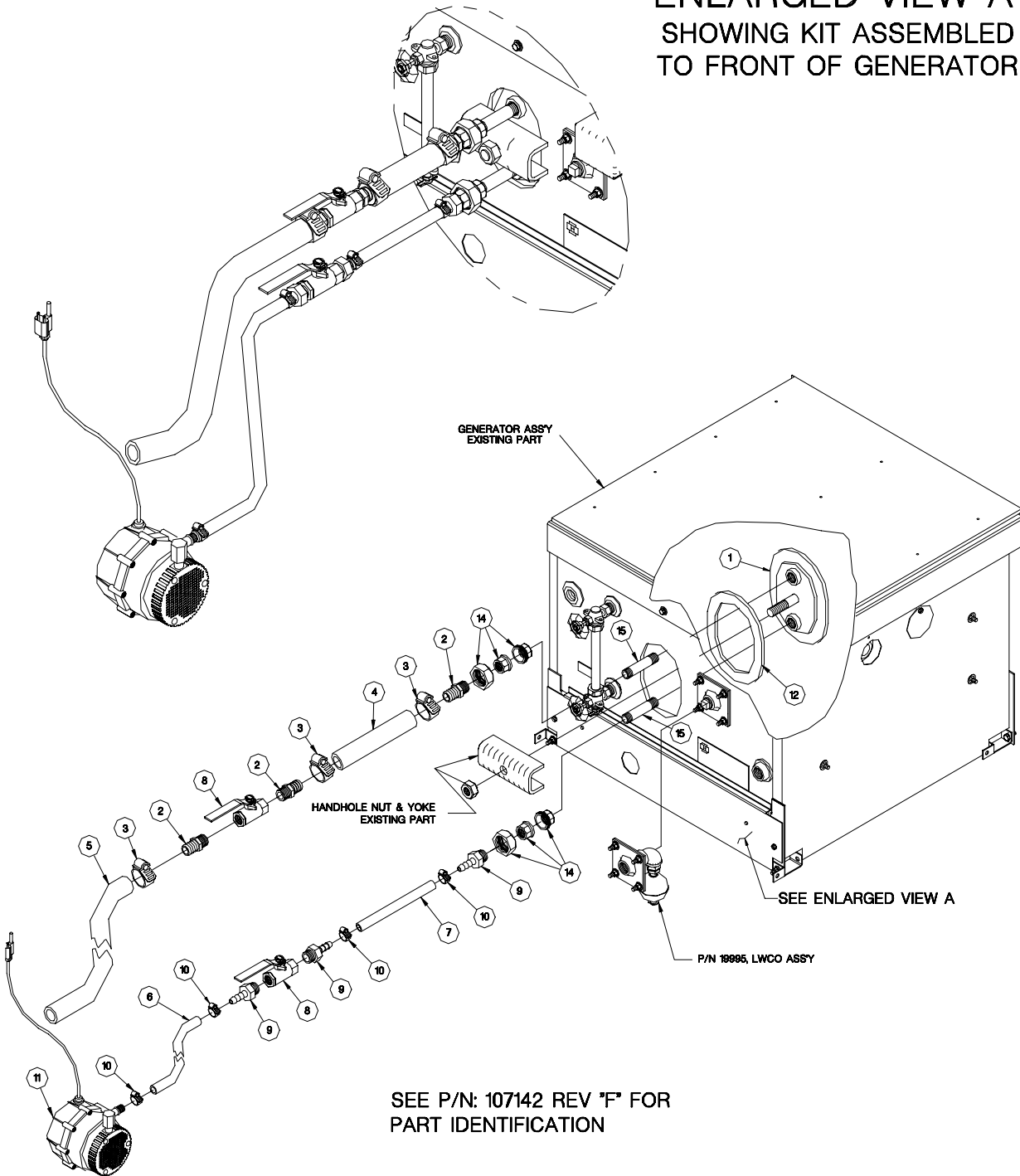

GAS BOILER/ELECTRIC BOILER FIELD REPLACEMENT VERSION (GAS SHOWN)

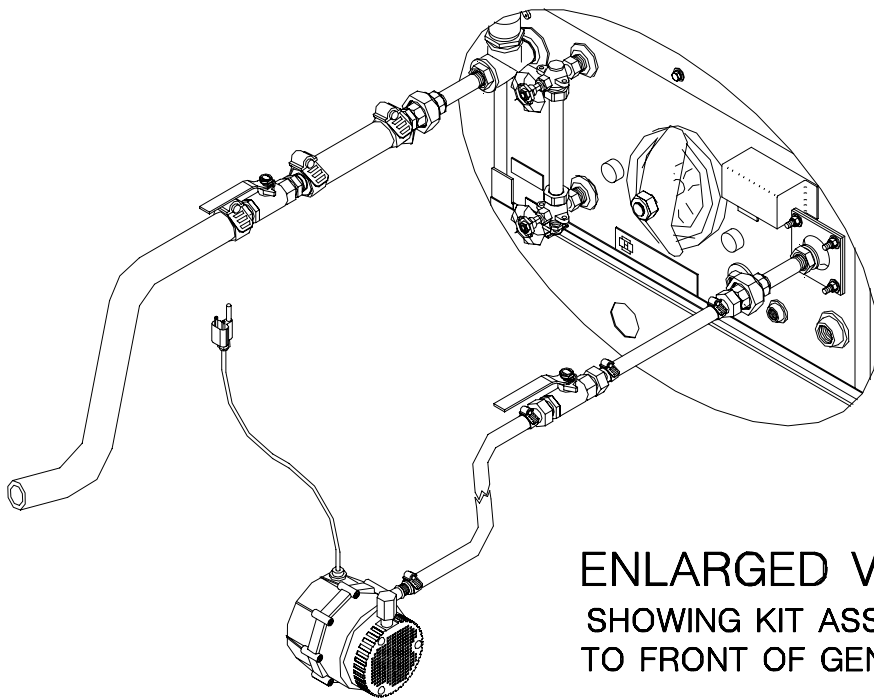

ENLARGED VIEW C
SHOWING KIT ASSEMBLED
TO FRONT OF GENERATOR

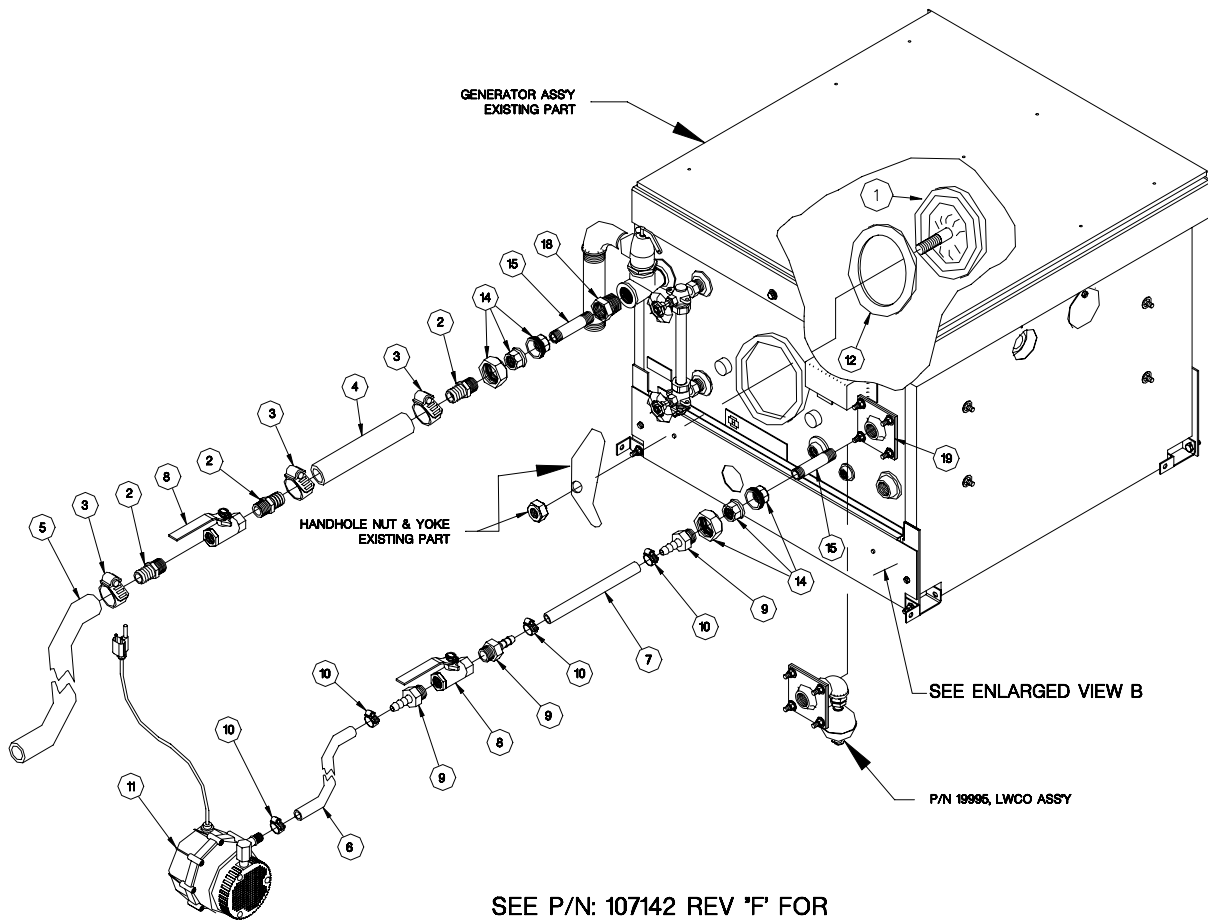

SEE P/N: 107142 REV 'F' FOR
PART IDENTIFICATION

GAS BOILER/ELECTRIC BOILER CURRENT PRODUCTION RELEASE (GAS SHOWN)

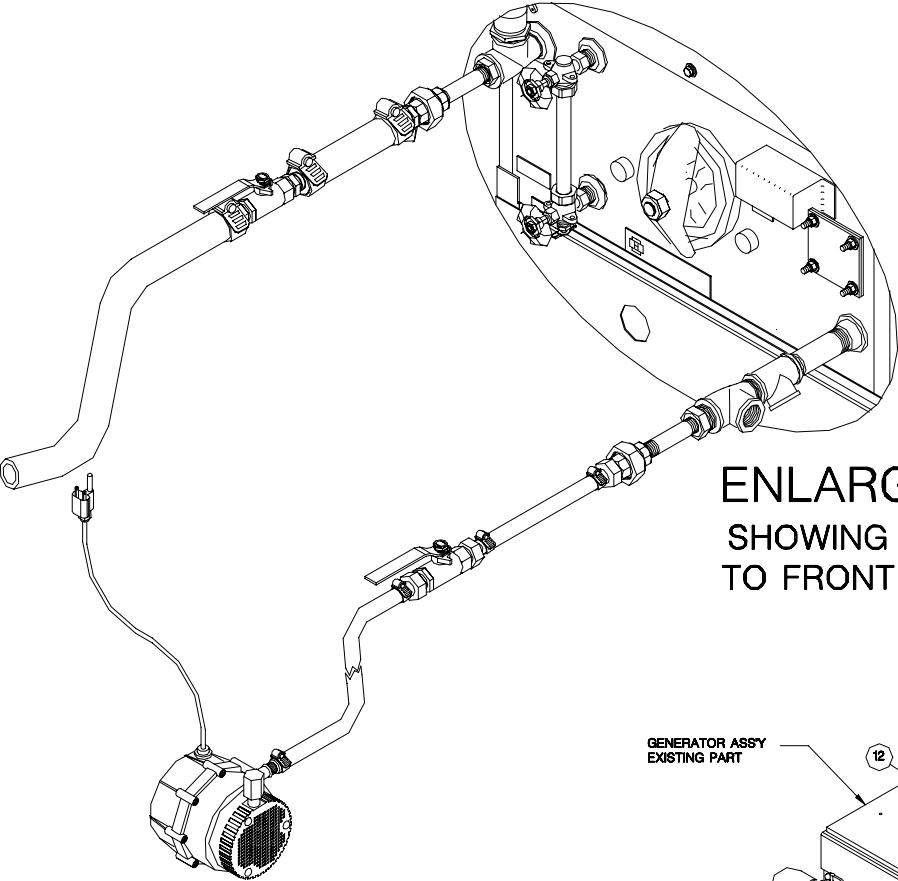

ENLARGED VIEW C
SHOWING KIT ASSEMBLED
TO FRONT OF GENERATOR

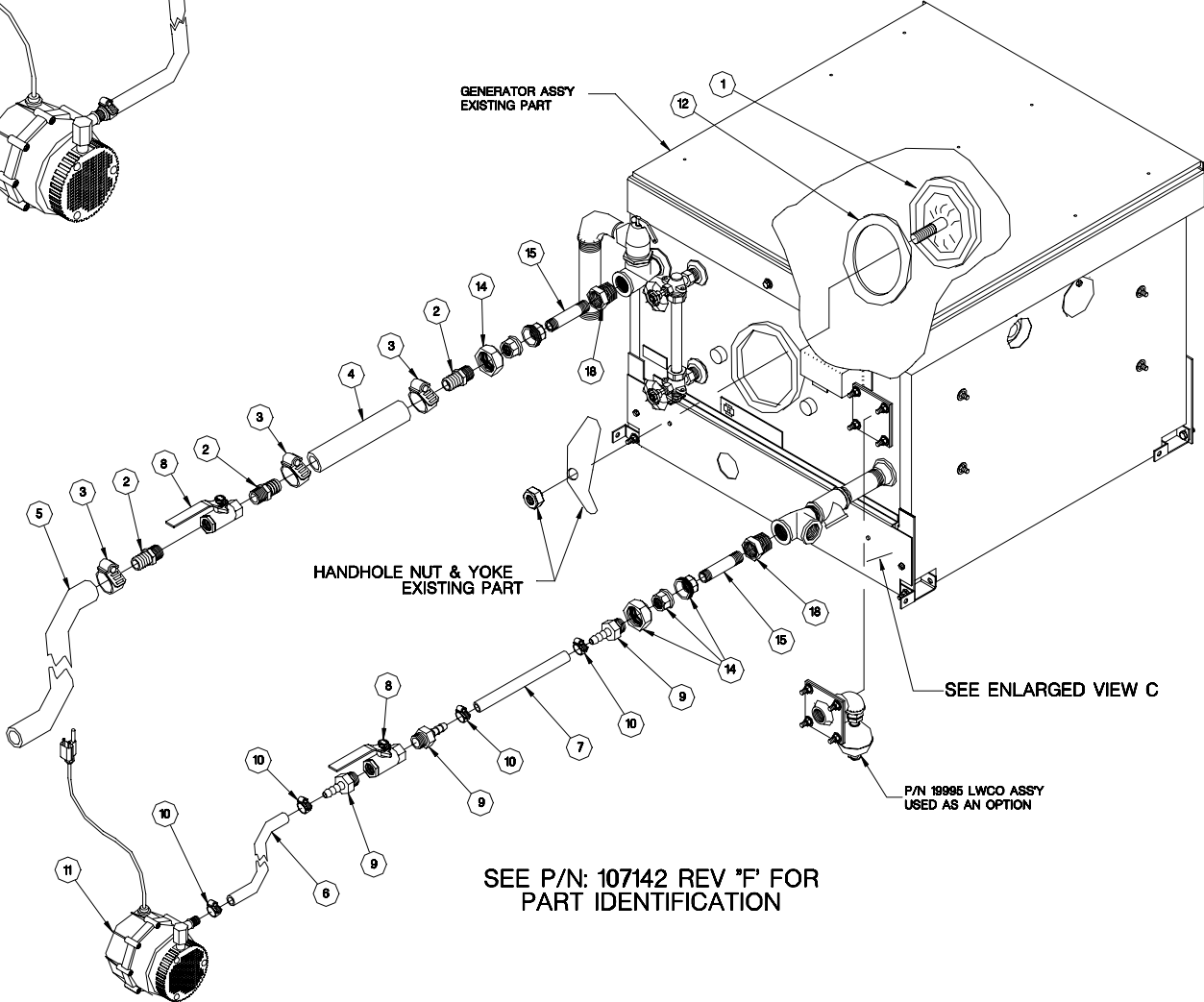

200/300KBTU DESCALING KIT PART LIST

(P/N: 107142)

ITEM	PART #	DESCRIPTION	QTY
1	437481	Plate Ass'y, Handhole w/Descaler Port	1
2	06241	Fitting, Hose Barb, 3/4 H x 1/2 MPT	3
3	03204	Clamp, Hose, Worm Drive	3
4	1088190600	3/4 Hose For Descaling Syst, 6.000" Lg	1
5	1088193600	3/4 Hose For Descaling Syst, 36.000" Lg	1
6	1088203600	1/2 Hose For Descaling Syst, 36.000" Lg	1
7	1088200600	1/2 Hose For Descaling Syst, 6.000" Lg	1
8	22212	Valve, Ball, 1/2 Female	2
9	06237	Fitting, Hose, Barb, 1/2H X 1/2 MPT	3
10	106219	Clamp, Hose Worm Drive	4
11	107131	Pump, Submersible, Boiler Descaler Kit	1
12	07106	Gasket, Handhole	1
13	107199	Bucket W/Lid, 5 Gallon	1
14	23103	Union, 0.500, Brass	2
15	14331	Nipple, 0.500 NPT x 2.500 Lg, Sch 40	2
16	108815	Label, Descaling System	1
17	108845	Envelope, Vinyl, 10" x 13", Short Side Opening	1
18	02566	Bushing, Reducing, 3/4 x 1/2	2
19	41943	Plate Ass'y, Mounting, Weldment	1
20	260 ALK	Instructions, Descaling Installation	1
21	260 ALP	Instructions, Piping Conversion	1