

LET.	REVISIONS	DATE	BY
A	ADDED P/N 108898, P/N 23110 WAS	05-23-94	EAG
-	QTY(18), P/N 108899 WAS 14685		
-	PER E.O. #C-2843		

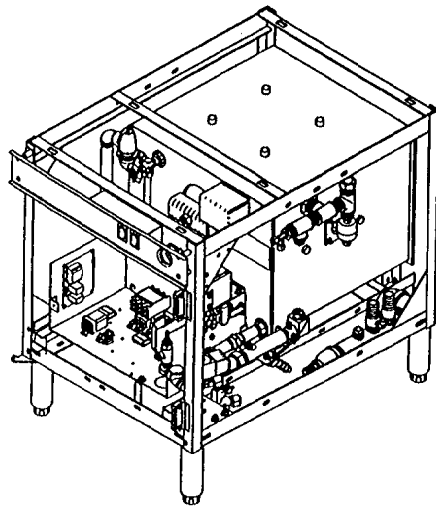

ASSEMBLED VIEW

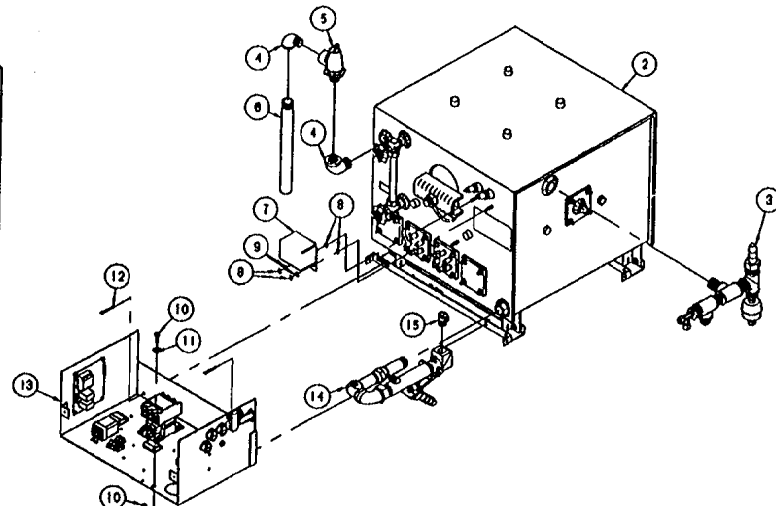

SEE DETAIL 'A'

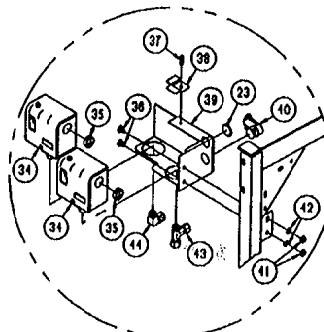
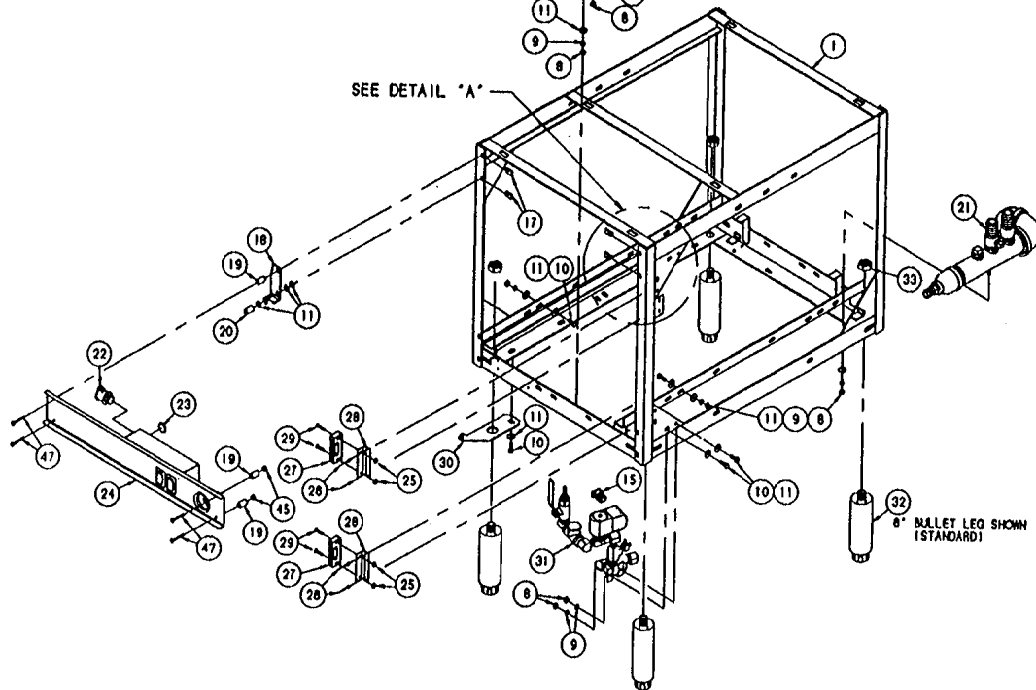

DETAIL A

47	4	108898	SCREW, TRUSS HD, PHLPS, 10-24 X 1-1/2
48	A/R	00934	SEALANT, RECTORSAL
45	2	19552	SPACER, .158 LONG
44	1	08196	FITTING, COMP, 3/8 X 1/4 IPT, 90°
43	1	100893	FITTING, COMP TEE 3/8 X 1/4 IPT X 3/4
42	2	23137	WASHER, LOCK INT. TOOTH, 1/4 5/8
41	2	14888	NUT, HEX JAM, 1/4-20, 5/8
40	1	105247	CONNECTOR, 1/2 X 90° SNAP-TITE
39	1	529241	BRACKET, PRESSURE SWITCH, GAS/ELECT
38	1	52499	BRACKET, PRESSURE SWITCH RETAINER
37	1	19146	SCREW, HEX WASHER HEAD, #10 X .5
36	2	19218	SCREW, HEX HEAD, 1/4-20 X .375 5/8
35	2	02599	BUSHING, INSULATING 3/8 X 1/2 HEYCO
34	2	19947	SWITCH, PRESSURE CONTROL
33	4	14888	NUT, HEX JAM 3/4-10 ZINC PLTD
32	4	08158	LEG BULLET 8"
31	1	44070	WATER FEED ASSY, REV BEND GEN
30	1	1026892	HINGE, LOWER LEFT HINGE
29	4	19206	SCREW, RD. HEAD 8-32 X 1 ZINC PLTD
28	2	53274	CLIP, MAGNET CATCH 5/8
27	2	03100	CATCH, MAGNETIC
26	A/R	18358	RIVET, 1/8 DIA. FLUSH BREAK 5/8
25	4	14874	NUT, HEX 8-32 ZINC PLATED
24	1	1048073	CONSOLE ASSY, ROOM 2 SWITCH
23	2	19329	PLUG, SNAP-IN 1/2" FOR 1/8" HOLE
22	1	105218	CONNECTOR, GREENFIELD 1/2 STRAIGHT
21	1	42749	DRAIN ASSEMBLY
20	1	195512	SPACER
19	3	19553	SPACER
18	1	412182	BRACKET, ASS'Y, TOP HINGE, L.S.
17	4	108899	NUT, SLIP ON, 10-24, TINNEMAN
16	1	52529	BRACKET, MOUNTING, ELECTRIC BOX
15	2	105249	CONNECTOR, GREENFIELD 3/8 STRAIGHT
14	1	40889	BLOWDOWN ASSY, 24CEM, ELECTRIC 'J'
13	1	NFX001	ELECTRIC BOX ASSEMBLY
12	2	19292	SCREW, ROUND HEAD, SLTD 1/4-20 X 1"
11	12	23110	WASHER, FLAT 1/4 X 5/8 X .085
10	7	19280	SCREW, HEX HEAD, 1/4-20 X 3/4
9	9	23103	WASHER, LOCK 1/4 KATLINK STYLE
8	11	14818	NUT, HEX 1/4-20 5/8
7	1	52303	BOX, PROBE COVER, 2 PROBES, A.C.S.
6	1	14487	NIPLLE, T.O.E., 3/4" X 8", BLACK
5	1	22131	VALVE, SAFETY, 3/4" IS PBI, BRONZE
4	2	03259	ELBOW, STREET, 3/4", 90° BLACK
3	1	428124	STEAM OUTLET ASSEMBLY
-	-	408201W1	ELECT GENERATOR W/REF PARTS 4 HEATA
2	-	408201W3	ELECT GENERATOR W/REF PARTS 3 HEATA
-	-	408201W2	ELECT GENERATOR W/REF PARTS 2 HEATA
-	-	411121	BASE, WELDMENT, 800MM, A.C.S.
1	-	41112	BASE WELDMENT, 800MM, 5/8

ITEM	QTY.	PART NO.	DESCRIPTION
<b>CLEVELAND RANGE INC.</b>			
1339 East 179th St., Cleveland, Ohio 44110-3574			
DECIMAL	SCALE	DRAWN BY	APPROVED BY
± N/A	1/8"=1	E. GRIEYAS	M.T.
ANGULAR	TITLE	BASE ASSEMBLY, ELECTRIC GENERATOR	
± N/A		800MM, 24KW/38KW/48KW	
CK	DATE	DRAWING NO.	REV.
	10-08-93	C - DFD0001	A

THIS DESIGN DESCRIBES A PROPRIETARY ITEM AND IS THE PROPERTY OF CLEVELAND RANGE. THIS DRAWING IS NOT TO BE COPIED OR USED WITHOUT THE APPROVAL OF CLEVELAND RANGE.

NEXT ASS'Y: DFD0014

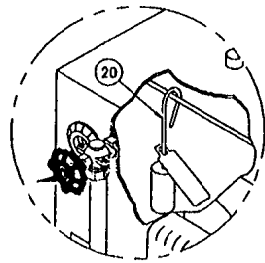
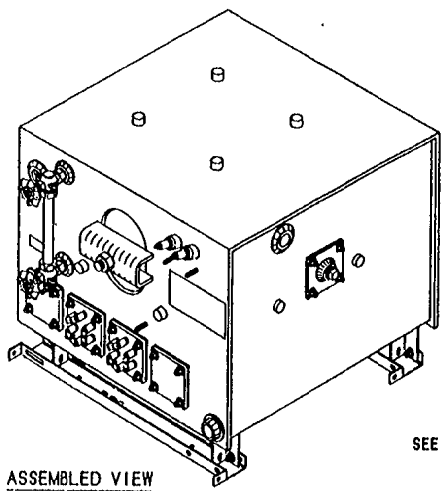

DETAIL "A"  
INSTALL ITEM 20 AS SHOWN  
INSIDE GENERATOR

- NOTES:
1. CHANNEL SUPPORT SHOWN (P/N 89966) IS USED ON 800MM BASE. CHANNEL SUPPORT NOT SHOWN (P/N 89967) IS USED ON 900 & 1050MM BASES.
  2. 9KW HEATER IS RED LOBSTER UNITS ONLY.

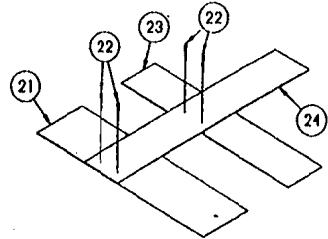

PLACE BAFFLES ACROSS RODS  
ON THE INSIDE OF GENERATOR  
IN CONFIGURATION SHOWN

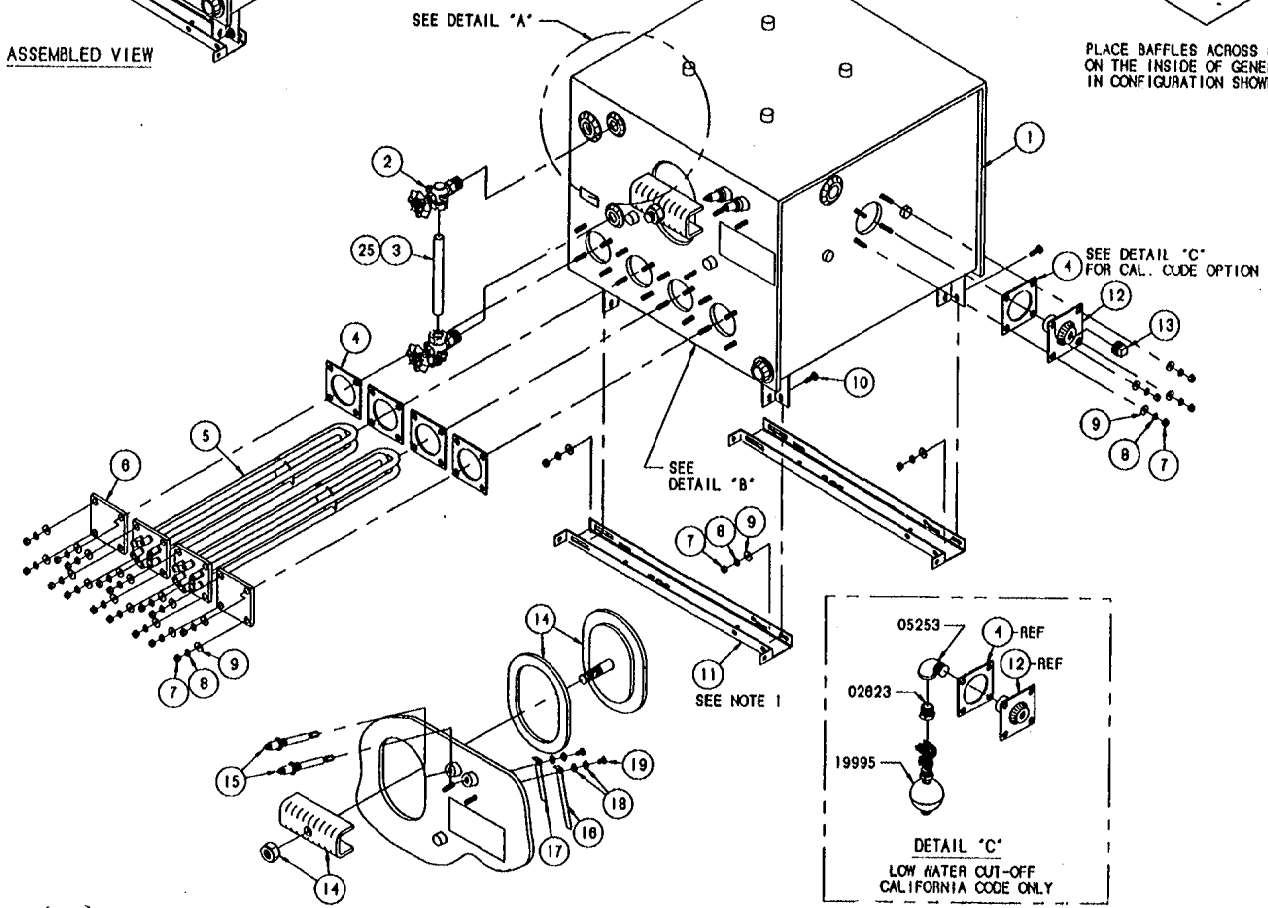

ITEM	QTY	PART NO.	DESCRIPTION
25	A/R	00934	SEALANT, RECTORSEAL
24	1	52165	BAFFLE, KEEPER, ELECTRIC BOILER
23	1	102384	BAFFLE, CENTER, ELECTRIC STEAM GEN
22	4	18328	PIN, COTTER, 1/16 X 1, BRASS
21	1	52165	BAFFLE, FRONT, ELECTRIC BOILER
20	1	43895	ANODE ASSM CORROSION PREVENTATIVE
19	2	19218	SCREW, HEX HEAD, 1/4-20 X 3/8 S/S
18	4	23151	WASHER, INTERNAL TOOTH LOCK, 1/4
17	1	82452	EXTENSION, WATER PROBE 1/2 X 3-1/8
16	1	82453	EXTENSION, WATER PROBE 1/2 X 4-5/8
15	2	16871	PROBE WARRICK, 4-5/16" LG
14	1	40421	HAND HOLD PLATE & BAR ASSEMBLY
13	1	16802	PLUG, SQUARE 1/2 PIPE, BLACK
12	1	41943	PLATE, MOUNTING
11	-	89966	SUPPORT, GEN MTG CHANNEL 800MM S/S
11	-	89967	SUPPORT, GEN MTG CHANNEL 900/1050MM
10	4	19288	SCREW, HEX HEAD, 1/4-20 X 3/4
9	24	23110	WASHER, FLAT, 1/4 S/S
8	24	23105	WASHER, LOCK MED. PAT., 1/4" S/S
7	24	14618	NUT, HEX, 1/4-20, S/S
6	2	16546	PLATE, BLOCK-OFF
2	2	08244	HEATER, 9 KW, 600 V, 1 PHASE
2	2	08243	HEATER, 9 KW, 440/480 V, 1 PHASE
2	2	08242	HEATER, 9 KW, 220/240 V, 1 PHASE
2	2	08241	HEATER, 9 KW, 208 V, 1 PHASE
2	2	08237	HEATER, 9 KW, 440/480 V, 3 PHASE
2	2	08236	HEATER, 9 KW, 220/240 V, 3 PHASE
2	2	08235	HEATER, 9 KW, 208 V, 3 PHASE
2	2	08234	HEATER, 9 KW, 600 V, 3 PHASE
2	2	08210	HEATER, 12 KW, 440/480 V, 1 PHASE
2	2	08215	HEATER, 12 KW, 230/240 V, 1 PHASE
2	2	08214	HEATER, 12 KW, 208/220 V, 1 PHASE
2	2	08197	HEATER, 12 KW, 220/380 V, 3 PHASE
2	2	08187	HEATER, 12 KW, 140, 480 V, 3 PHASE
2	2	08180	HEATER, 12 KW, 230/240 V, 3 PHASE
2	2	08185	HEATER, 12 KW, 208 V, 3 PHASE
2	2	08184	HEATER, 12 KW, 575 V, 3 PHASE
2	2	08163	HEATER, 12 KW, 600 V, 3 PHASE
2	2	08157	HEATER, 9 KW, 240/360 V, 3 PHASE
2	2	08156	HEATER, 9 KW, 240/415 V, 3 PHASE
2	2	08155	HEATER, 12 KW, 240/415 V, 3 PHASE
4	5	07126	GASKET, HEATER
3	1	07302	GAUGE, WATER, 5/8 X 8, GLASS
2	1	07176	GAUGE, FITTINGS, WATER, 1/2"
1	1	408201	GENERATOR, ASSY 2 PROBE ELECT

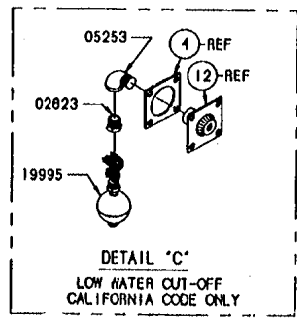

DETAIL "C"  
LOW WATER CUT-OFF  
CALIFORNIA CODE ONLY

HT ASS'Y: DFD0001  
DFE0002  
DFP0003

THIS DESIGN IS A PROPRIETARY ITEM OF CLEVELAND RANGE AND IS THE PROPERTY OF CLEVELAND RANGE. IT IS NOT TO BE COPIED OR USED WITHOUT THE APPROVAL OF CLEVELAND RANGE.

TOLERANCES (EXCEPT AS NOTED)

SCALE: 3/16"=1"

DATE: 10-08-93

DRAWING NO.: C - 408201W2

REV: -

CLEVELAND RANGE INC.  
1533 East 179th St., Cleveland, Ohio 44110-2571

DRAWN BY: E. GRIVIN

APPROVED BY:

TITLE: ELECTRIC GENERATOR PROBE

SEMBLY:

LET.	REVISIONS	DATE	BY

NOTES:  
 1. CHANNEL SUPPORT SHOWN (P/N 89988) IS USED ON 600MM BASE. CHANNEL SUPPORT NOT SHOWN (P/N 89987) IS USED ON 900 & 1030MM BASES.

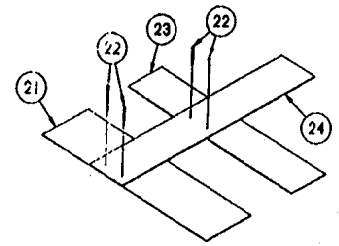

PLACE BAFFLES ACROSS RODS ON THE INSIDE OF GENERATOR IN CONFIGURATION SHOWN

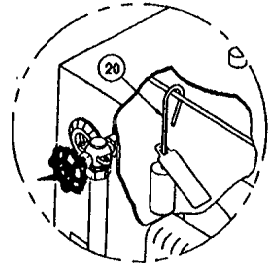

DETAIL "A"  
 INSTALL ITEM 20 AS SHOWN INSIDE GENERATOR

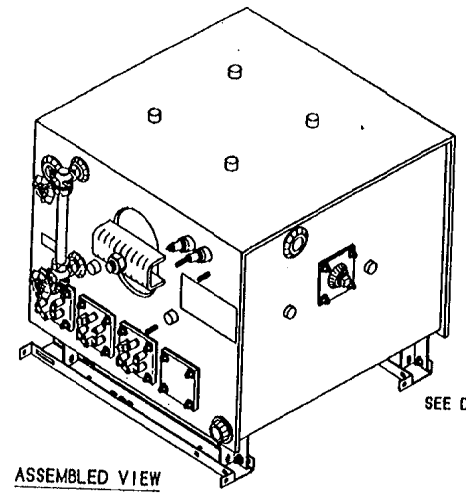

ASSEMBLED VIEW

SEE DETAIL "A"

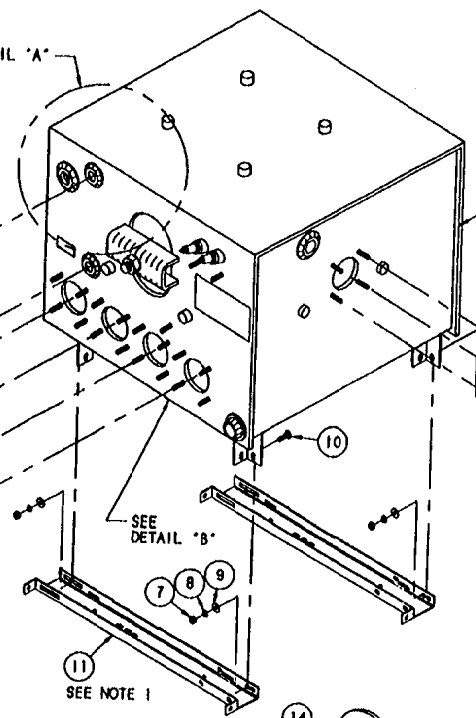

SEE DETAIL "C" FOR CAL. CODE OPTION

SEE DETAIL "B"

SEE NOTE 1

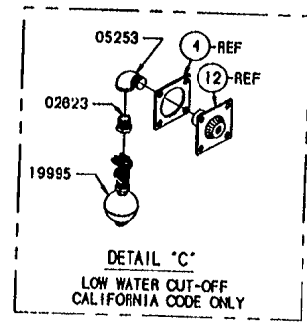

DETAIL "C"  
 LOW WATER CUT-OFF CALIFORNIA CODE ONLY

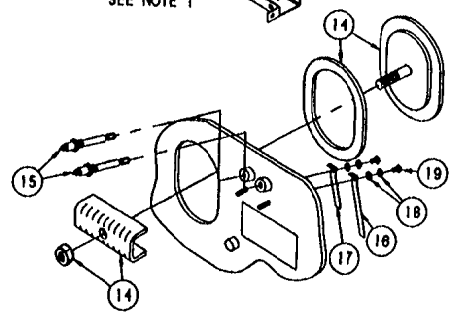

DETAIL "B"

ITEM	QTY	PART NO.	DESCRIPTION
25	1	00934	SEALANT, RECTORSEAL
24	1	52185	BAFFLE, KEEPER, ELECTRIC BOILER
23	1	102384	BAFFLE, CENTER, ELECTRIC STEAM GEN
22	4	18328	PIN, COTTER, 1/18 X 1, BRASS
21	1	52185	BAFFLE, FRONT, ELECTRIC BOILER
20	1	43895	ANODE ASSM CORROSION PREVENTATIVE
19	2	19218	SCREW, HEX HEAD, 1/4-20 X 3/8 S/S
18	4	23151	WASHER, INTERNAL TOOTH LOCK, 1/4
17	1	82452	EXTENSION, WATER PROBE 1/2 X 3-1/8
16	1	82453	EXTENSION, WATER PROBE 1/2 X 4-5/8
15	2	16871	PROBE WARRICK, 4-5/16" LG
14	1	40421	HAND HOLD PLATE & BAR ASSEMBLY
13	1	16802	PLUG, SQUARE 1/2 PIPE, BLACK
12	1	41943	PLATE, MOUNTING
11	-	89988	SUPPORT, GEN MTG CHANNEL 600MM S/S
10	-	89987	SUPPORT, GEN MTG CHANNEL 900/1030MM
9	4	19288	SCREW, HEX HEAD, 1/4-20 X 3/4
8	24	23116	WASHER, FLAT, 1/4 S/S
7	24	23105	WASHER, LOCK MED. PAT., 1/4" S/S
6	24	14818	NUT, HEX, 1/4-20, S/S
5	3	08197	HEATER, 12 KW, 220/380 V, 3 PHASE
4	3	08167	HEATER, 12 KW, 440/480 V, 3 PHASE
3	3	08188	HEATER, 12 KW, 230/240 V, 3 PHASE
2	3	08105	HEATER, 12 KW, 208 V, 3 PHASE
1	3	08103	HEATER, 12 KW, 600 V, 3 PHASE
1	3	08155	HEATER, 12 KW, 240/415 V, 3 PHASE
1	5	07128	GASKET, HEATER
1	1	07302	GAUGE, WATER, 5/8 X 0, GLASS
1	1	07176	GAUGE, FITTINGS, WATER, 1/2"
1	1	40820	GENERATOR, ASSY 2 PROBE ELECT

THIS DESIGN DESCRIBES A PROPRIETARY ITEM AND IS THE PROPERTY OF CLEVELAND RANGE. THIS DRAWING IS NOT TO BE COPIED OR USED WITHOUT THE APPROVAL OF CLEVELAND RANGE.

NEXT ASS'Y: DFD0001  
 DFE0002  
 DFF0003

TOLERANCES (UNLESS AS NOTED)		CLEVELAND RANGE INC. 1323 East 178th St. Cleveland, Ohio 44110-2374	
DECIMAL	3/16±	DRAWN BY	E. GRIVEAS
INCHES	1/16±	APPROVED BY	
TITLE		ELECTRIC GENERATOR ASSEMBLY	
DESCRIPTION		2 PROBE, 3 HEATER	
DATE	10-08-93	DRAWING NO.	C - 408201WR

NOTES:

- CHANNEL SUPPORT SHOWN (P/N 69986) IS USED ON 600MM BASE. CHANNEL SUPPORT NOT SHOWN (P/N 69987) IS USED ON 900 & 1050MM BASES.

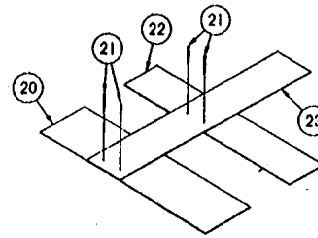

PLACE BAFFLES ACROSS RODS ON THE INSIDE OF GENERATOR IN CONFIGURATION SHOWN

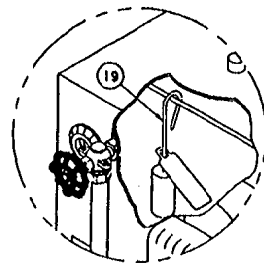

DETAIL 'A'  
INSTALL ITEM 20 AS SHOWN INSIDE GENERATOR

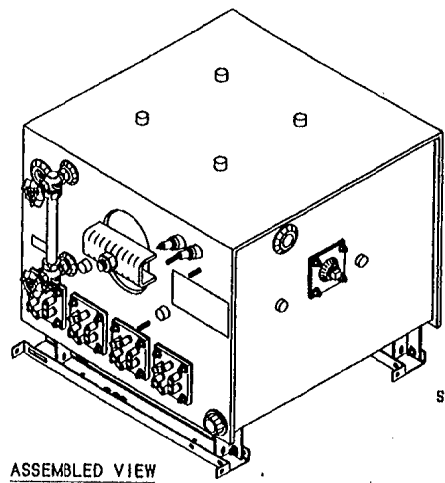

ASSEMBLED VIEW

SEE DETAIL 'A'

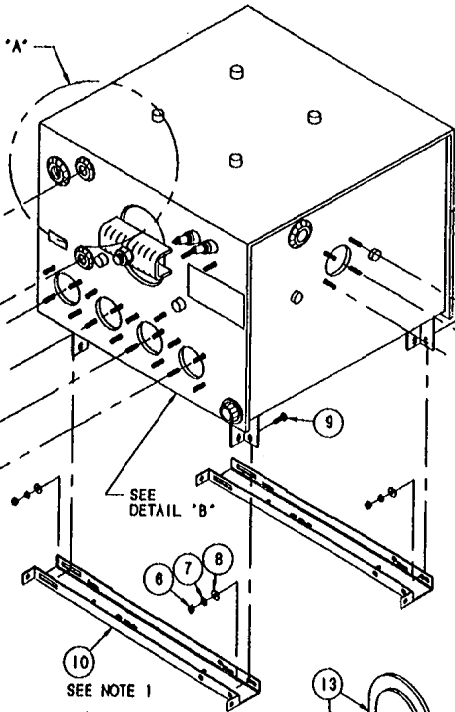

SEE DETAIL 'C' FOR CAL. CODE OPTION

SEE DETAIL 'B'

SEE NOTE 1

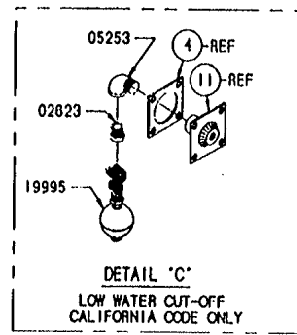

DETAIL 'C'  
LOW WATER CUT-OFF CALIFORNIA CODE ONLY

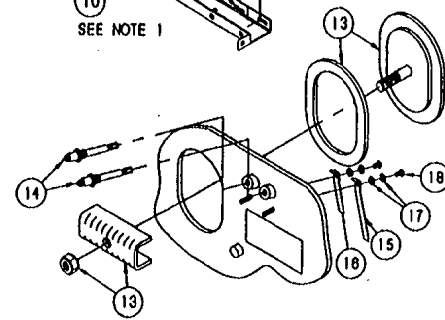

DETAIL 'B'

ITEM	QTY	PART NO.	DESCRIPTION
24	1	00934	SEALANT, RECTORSEAL
23	1	52165	BAFFLE, KEEPER, ELECTRIC BOILER
22	1	102384	BAFFLE, CENTER, ELECTRIC STEAM GEN
21	4	16328	PIN, COTTER, 1/16 X 1, BRASS
20	1	52165	BAFFLE, FRONT, ELECTRIC BOILER
19	1	43895	ANODE ASSM CORROSION PREVENTATIVE
18	2	19218	SCREW, HEX HEAD, 1/4-20 X 3/8 S/S
17	4	29151	WASHER, INTERNAL TOOTH LOCK, 1/4
16	1	62452	EXTENSION, WATER PROBE 1/2 X 3-1/8
15	1	62453	EXTENSION, WATER PROBE 1/2 X 4-5/8
14	2	16871	PROBE WARRICK, 4-5/16" LG
13	1	40421	HAND HOLD PLATE & BAR ASSEMBLY
12	1	16862	PLUG, SQUARE 1/2 PIPE, BLACK
11	1	41943	PLATE, MOUNTING
		69987	SUPPORT, GEN MTG CHANNEL 600MM S/S
10		69987	SUPPORT, GEN MTG CHANNEL 900/1050MM
9	4	19288	SCREW, HEX HEAD, 1/4-20 X 3/4
8	24	23116	WASHER, FLAT, 1/4 S/S
7	24	23105	WASHER, LOCK MED. PAT., 1/4" S/S
6	24	14818	NUT, HEX, 1/4-20, S/S
		08197	HEATER, 12 KW, 220/380 V, 3 PHASE
		08107	HEATER, 12 KW, 440/480 V, 3 PHASE
		08168	HEATER, 12 KW, 230/240 V, 3 PHASE
		08185	HEATER, 12 KW, 208 V, 3 PHASE
		08184	HEATER, 12 KW, 575 V, 3 PHASE
		08183	HEATER, 12 KW, 600 V, 3 PHASE
		08155	HEATER, 12 KW, 240/415 V, 3 PHASE
4	5	07128	GASKET, HEATER
3	1	07302	GAUGE, WATER, 5/8 X 6, GLASS
2	1	07178	GAUGE, FITTINGS, WATER, 1/2"
1	1	408201	GENERATOR, ASSY 2 PROBE ELECT

THIS DESIGN IS A PROPRIETARY ITEM AND IS THE PROPERTY OF CLEVELAND RANGE. THIS DRAWING IS NOT TO BE COPIED OR USED WITHOUT THE APPROVAL OF CLEVELAND RANGE.

NEXT ASS'Y: DFD0001  
DFE0002  
DFP0003

CLEVELAND RANGE INC. 1333 East 178th St. Cleveland, Ohio 44110-2574			
DECIMAL # N/A	SCALE 3/16=1	DRAWN BY E. GRIVEAS	APPROVED BY
AREA/AN # N/A	TITLE ELECTRIC GENERA 2 PROBE, 4 i	WPLY	
DATE 10-06-93	DRAWING NO. C - 408201W4	REV	

NOTE:

1. THIS DRAWING REFLECTS MOST COMMON CONFIGURATION OF ELECTRICAL BOX (24KW208V).
2. REFER TO DWG. NFX0002 FOR ELECTRIC BOX W/INTERMITTENT BLOWDOWN.

LET.	REVISIONS	DATE	BY
------	-----------	------	----

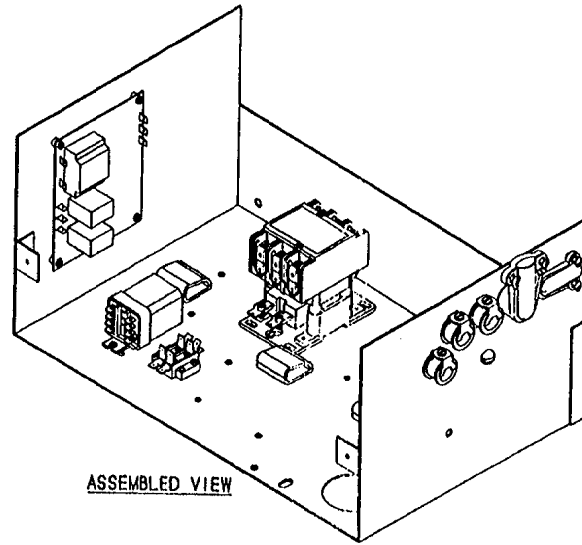

ASSEMBLED VIEW

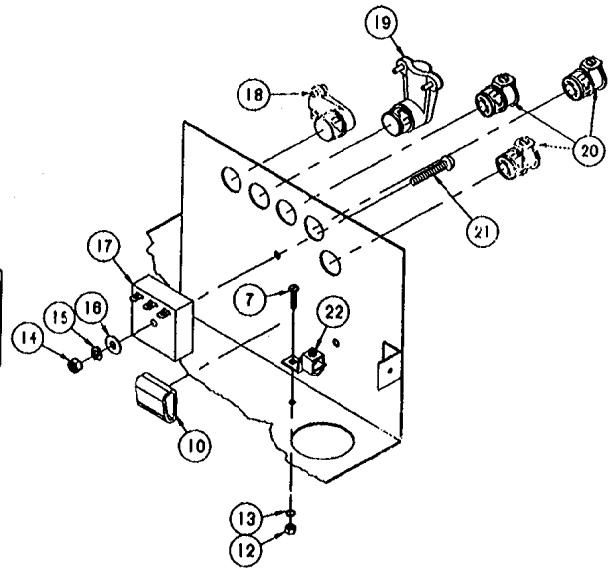
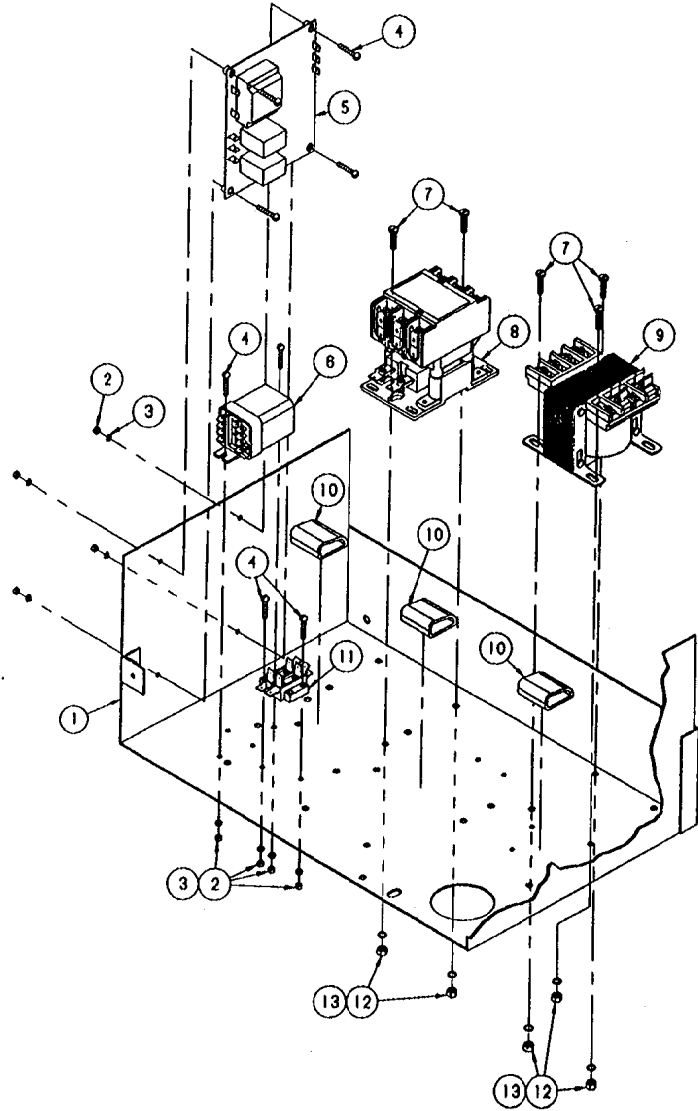

INTERIOR RIGHT SIDE VIEW OF ELECTRICAL BOX, ROTATED 90°

ITEM	QTY.	PART NO.	DESCRIPTION
22	1	12331	LUG, GROUND, SOLDERLESS, FOR 2-GA. WIRE
21	1	19285	SCREW, ROUND HEAD, 1/4-20 X 1-1/2, S/S
20	3	105243	CONNECTOR, GREENFIELD 3/8" STRAIGHT
19	1	105247	CONNECTOR, GREENFIELD 1/2 X 90°SNAPTITE
18	1	105245	CONNECTOR, GREENFIELD 3/8 X 90°SNAPTITE
17	1	20478	TIMER, SOLID STATE INTERVAL 3 MINUTE
16	1	23116	WASHER, FLAT, 1/4" ID X .085 THK
15	1	23137	WASHER, LOCK, INT. TOOTH, 1/4", S/S
14	1	14818	NUT, HEX, 1/4-20, S/S, FULL FINISHED
13	8	23114	WASHER, LOCK INT. TOOTH #10 TYPE A OR B
12	8	14854	NUT, HEX #10-24 STEEL
11	1	44188	TERMINAL BLOCK ASM, 2 POLE
10	4	23432	CLIP, MOUNTING, WIRE/CABLE, 1.25 X 1.50
9	1	20535	TRANSFORMER, 150VA
8	1	03508	CONTACTOR, 3 POLE, 75 AMP, 208/204V
7	5	19287	SCREW, PAN HEAD, 10-24 X .50", S/S
6	1	108581	RELAY, 120V, ELECTRIC GENERATOR
5	1	23198	CONTROL, WATER LEVEL
4	8	19163	SCREW, ROUND HEAD SLTD, 8-32 X .75
3	8	23111	WASHER, LOCK, INT. TOOTH #6 ZINC PLTD
2	8	14874	NUT, HEX, 8-32, ZINC PLTD
1	1	40937	BOX, WELDMENT, ELECTRIC

TOLERANCES (EXCEPT AS NOTED)		CLEVELAND RANGE INC.	
DECIMAL	SCALE	1333 East 179th St. Cleveland, Ohio 44110-2574	
± N/A	3/8=1	DRAWN BY	APPROVED BY
ANGULAR	TITLE	E. GRIVEAS	NLT
± N/A	ELECTRIC BOX ASSEMBLY		
	ELECTRIC GENERATOR		
DATE	DRAWING NO.	REV.	
02-10-94	C - NFX0001		

THIS DESIGN DESCRIBES A PROPRIETARY ITEM AND IS THE PROPERTY OF CLEVELAND RANGE. THIS DRAWING IS NOT TO BE COPIED OR USED WITHOUT THE APPROVAL OF CLEVELAND RANGE.

NEXT ASSY: DFD0001  
DFE0002  
DIF0003

CK 02-10-94 C - NFX0001

NOTE:

1. THIS DRAWING REFLECTS MOST COMMON CONFIGURATION OF ELECTRICAL BOX (24KW208V).

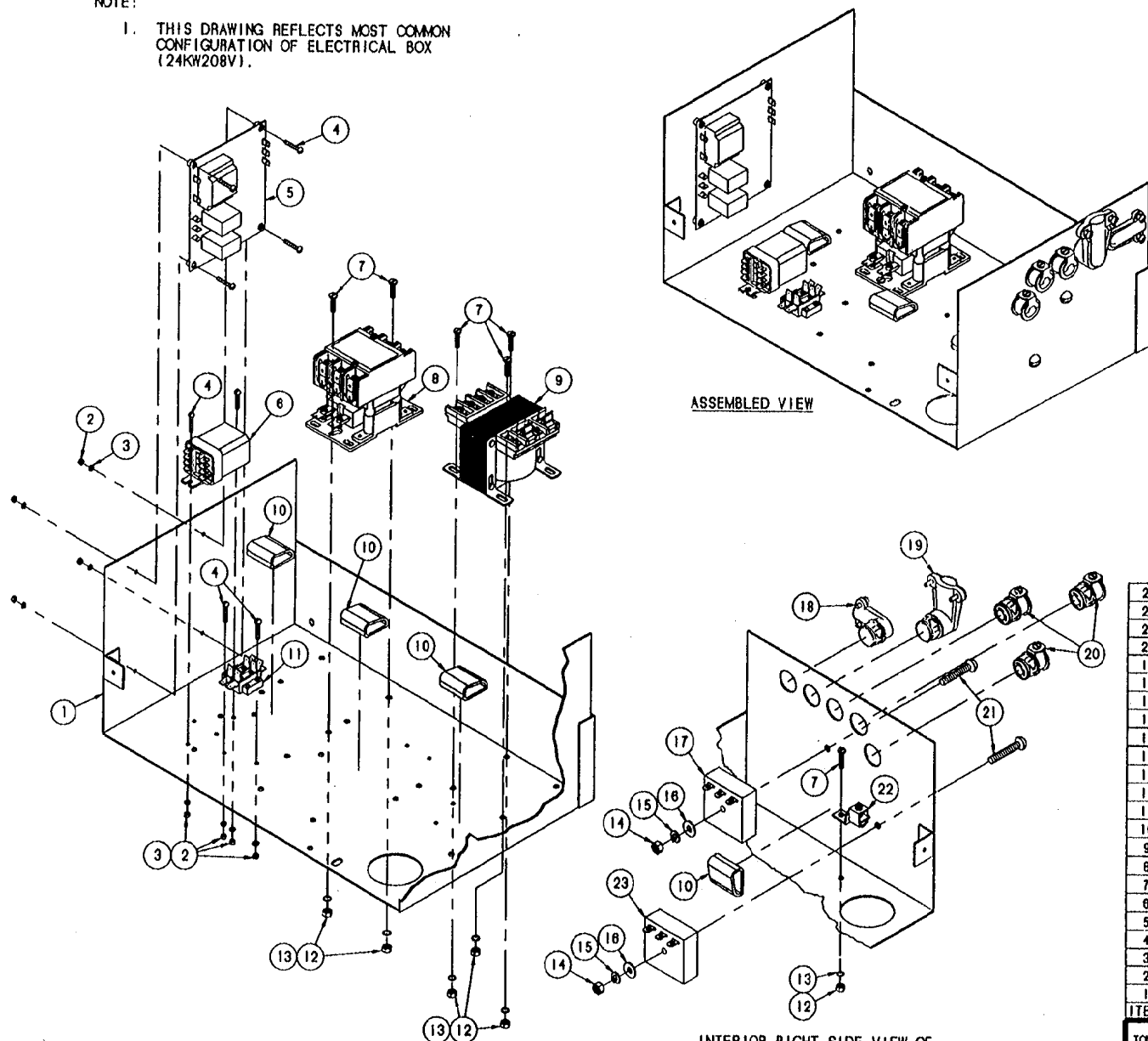

INTERIOR RIGHT SIDE VIEW OF ELECTRICAL BOX, ROTATED 90°

ITEM	QTY.	PART NO.	DESCRIPTION
23	1	104718	TIMER, RECYCLING, GENERATOR W/BLOWDOWN
22	1	12331	LUG, GROUND, SOLDERLESS, FOR 2-GA. WIRE
21	2	19285	SCREW, ROUND HEAD, 1/4-20 X 1-1/2, S/S
20	3	105249	CONNECTOR, GREENFIELD 3/8" STRAIGHT
19	1	105247	CONNECTOR, GREENFIELD 1/2 X 90° SNAPTITE
18	1	105245	CONNECTOR, GREENFIELD 3/8 X 90° SNAPTITE
17	1	20478	TIMER, SOLID STATE INTERVAL 3 MINUTE
16	2	23118	WASHER, FLAT, 1/4" ID X .065 THK
15	2	23137	WASHER, LOCK, INT. TOOTH, 1/4", S/S
14	2	14818	NUT, HEX, 1/4-20, S/S, FULL FINISHED
13	8	23114	WASHER, LOCK INT. TOOTH #10 TYPE A OR B
12	8	14854	NUT, HEX #10-24 STEEL
11	1	44168	TERMINAL BLOCK ASM. 2 POLE
10	4	23432	CLIP, MOUNTING, WIRE/CABLE, 1.25 X 1.50
9	1	20535	TRANSFORMER, 150VA
8	1	03508	CONTACTOR, 3 POLE, 75 AMP, 208/204V
7	5	19287	SCREW, PAN HEAD, 10-24 X .50", S/S
6	1	108581	RELAY, 120V, ELECTRIC GENERATOR
5	1	23198	CONTROL, WATER LEVEL
4	8	19183	SCREW, ROUND HEAD SLTD, 6-32 X .75
3	8	23111	WASHER, LOCK, INT. TOOTH #6 ZINC PLTD
2	8	14874	NUT, HEX, 6-32, ZINC PLTD
1	1	40937	BOX, WELDMENT, ELECTRIC

TOLERANCES (EXCEPT AS NOTED)		CLEVELAND RANGE INC. 1333 East 179th St. Cleveland, Ohio 44110-2574	
DECIMAL ± N/A	SCALE 3/8=1	DRAWN BY E. GRIVEAS	APPROVED BY NLT
ANGULAR ± N/A	TITLE ELECTRIC BOX ASSEMBLY W/INTERMITTENT BLOWDOWN, EL	GENERATOR	
CK	DATE 02-10-94	DRAWING NO. C - NFX0002	REV. -

THIS DESIGN / IS A PROPRIETARY ITEM AND IS THE P OF CLEVELAND RANGE. THIS DRAWING TO BE COPIED OR USED WITHOUT THE APPROVAL OF CLEVELAND RANGE.

OPTION FOR NEXT ASS'Y: DFD0001 DFE0002 DFF0003

NOTE: 1. MOUNT P/N 100064 TO LOWER RIGHT FRONT CUSSET (BASE FRAME).

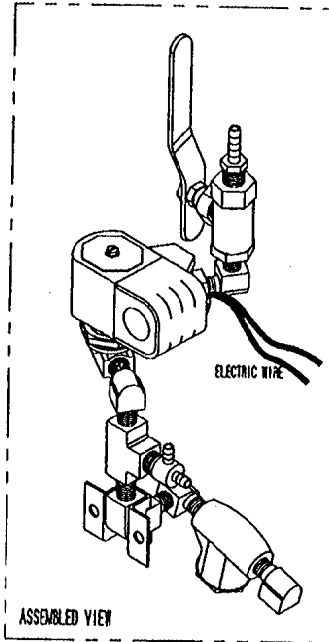
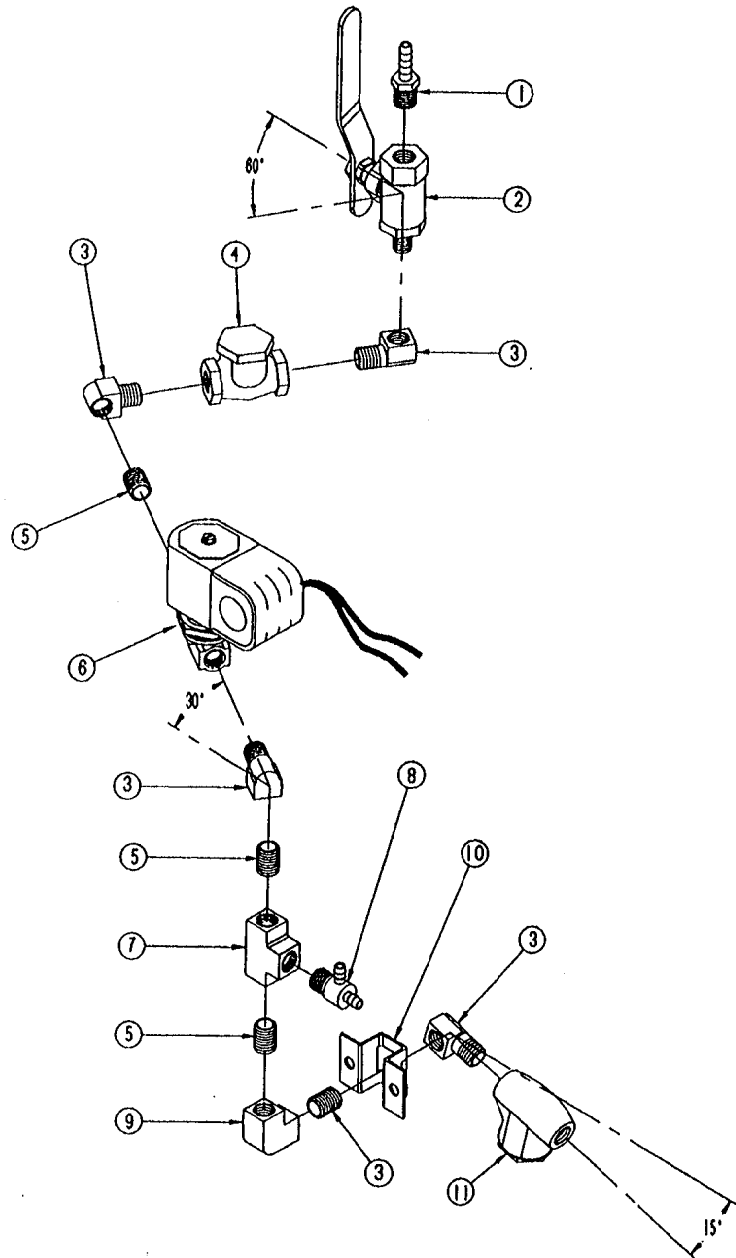

LET	REVISIONS	DATE	BY
G	ADDED 440702 PER E.O. C-1789	09-21-90	GS
H	P/N 08218 REMOVED FROM 440702 PER E.O. #C-1994	08-13-91	PJD
J	P/N 08195 REMOVED FROM 440702 PER E.O. #C-2082	11-28-91	SM
K	MOVED 440701 TO SEPERATE DRAWING	01-21-92	SM
L	NEW VALVE HOUSING ON P/N 22223 (PICTORIAL ONLY) E.O. #C-2221 R1	02-04-93	PJD
M	REMOVED ASSY 410702, P/N 104381 WAS 08218, P/N 108588 WAS 08195, PER E.O. #C-2448	08-22-93	EAG

SEE NOTE 1



QTY.	ITEM	PART No.	DESCRIPTION
1	11	19870	STRAINER, "Y" 1/4"
1	10	100064	CLAMP, MOUNTING
1	9	05236	ELBOW, 1/4 90° BRASS
1	8	108588	TEE, 1/4" ROSE BARB
1	7	20199	TEE, 1/4 BRASS
1	6	22223	VALVE, SOLENOID 1/4 NPT (CP200)
4	4	14304	HIPPLE, CLOSE 1/4 BRASS
1	4	22102	VALVE, CHECK 1/4 NPT
4	3	05235	ELBOW, STREET 1/4-90° BRASS
1	2	09278	VALVE, BALL 1/4 NPT
1	1	104381	FITTING, ROSE 1/4 H X 1/4 NPT

TOLERANCES (EXCEPT AS NOTED)			
DECIMAL	SCALE	DRAWN BY	APPROVED BY
± N/A	1/2	ANDJ	D.S.
ANGULAR	TITLE		
± 1°	PIPING ASSY., WATER FEED CONVECTION STEAMER ELECTRIC, AND GAS		
DATE	DRAWING NO.		REV.
OK	09-14-90	C- 44070	M

THIS DESIGN DESCRIBES A PROPRIETARY ITEM AND IS THE PROPERTY OF CLEVELAND RANGE. THIS DRAWING IS NOT TO BE COPIED OR USED WITHOUT THE APPROVAL OF CLEVELAND RANGE.

CLEVELAND RANGE INC.

1339 East 179th St. Cleveland, Ohio 44110-2574

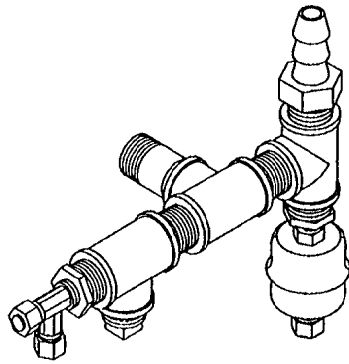

ASSEMBLED VIEW

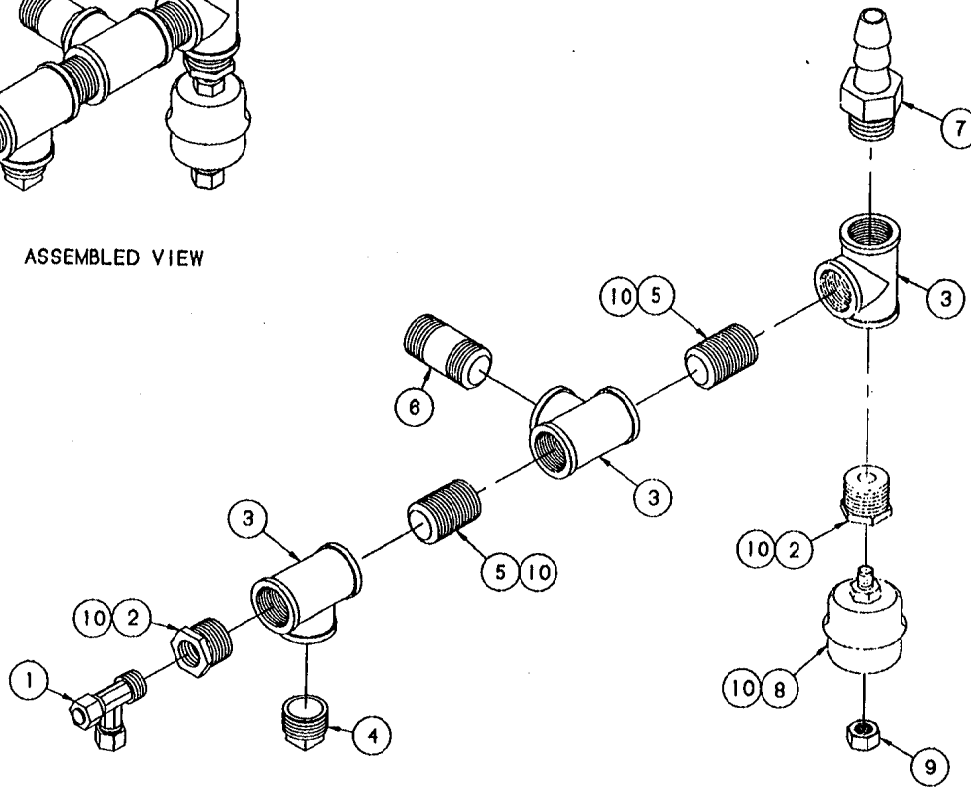

ITEM	QTY.	PART NO.	DESCRIPTION
10	A/R	00934	SEALANT, RECTORSEAL
9	1	14661	NUT, COMPRESSION, 1/4 TUBE, BRASS
8	1	101207	TRAP, THERMOSTATIC, 1/4" X 1/4"
7	1	08240	FITTING, HOSE BARB 3/4 HOSE X 3/4 NPT BRASS
6	1	14431	NIPPLE, 3/4 X 2, BRASS
5	2	14342	NIPPLE, 3/4 X CLOSE, BRASS
4	1	16607	PLUG, SQUARE HEAD, 3/4, BRASS
3	3	20208	TEE, 3/4 BRASS
2	2	02563	BUSHING, REDUCING, 3/4 X 1/4, BRASS
1	1	100883	FITTING, COMPR., TEE 3/8T X 3/8MPT X 3/8T

NEXT ASS'Y: DFE0002  
 DFF0003  
 DBE0005  
 DBF0008  
 DCE0007  
 DCF0008  
 DCE0009  
 DCF0010

THIS DESIGN DESCRIPTION IS THE PROPERTY OF CLEVELAND RANGE. THIS DRAWING IS UNLAWFULLY COPIED OR USED WITHOUT THE APPROVAL OF CLEVELAND RANGE.

PROPRIETARY ITEM  
 CLEVELAND RANGE.  
 COPIED OR USED  
 CLEVELAND RANGE.

TOLERANCES (EXCEPT AS NOTED)			
<b>CLEVELAND RANGE INC.</b> 1333 East 179th St. Cleveland, Ohio 44110-2574			
DECIMAL ± N/A	SCALE 1/2±1	DRAWN BY E. GRIVEAS	APPROVED BY NLT
ANGULAR ± N/A	TITLE STEAM OUTLET ASSEMBLY ELECTRIC GENERATOR		
CK	DATE 10-07-93	DRAWING NO. C - 428124	REV -



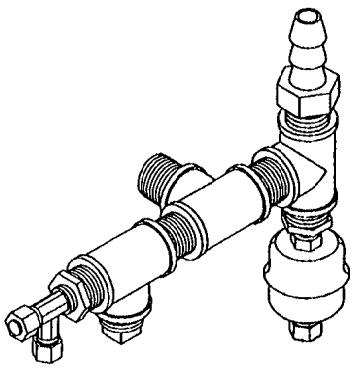

ASSEMBLED VIEW

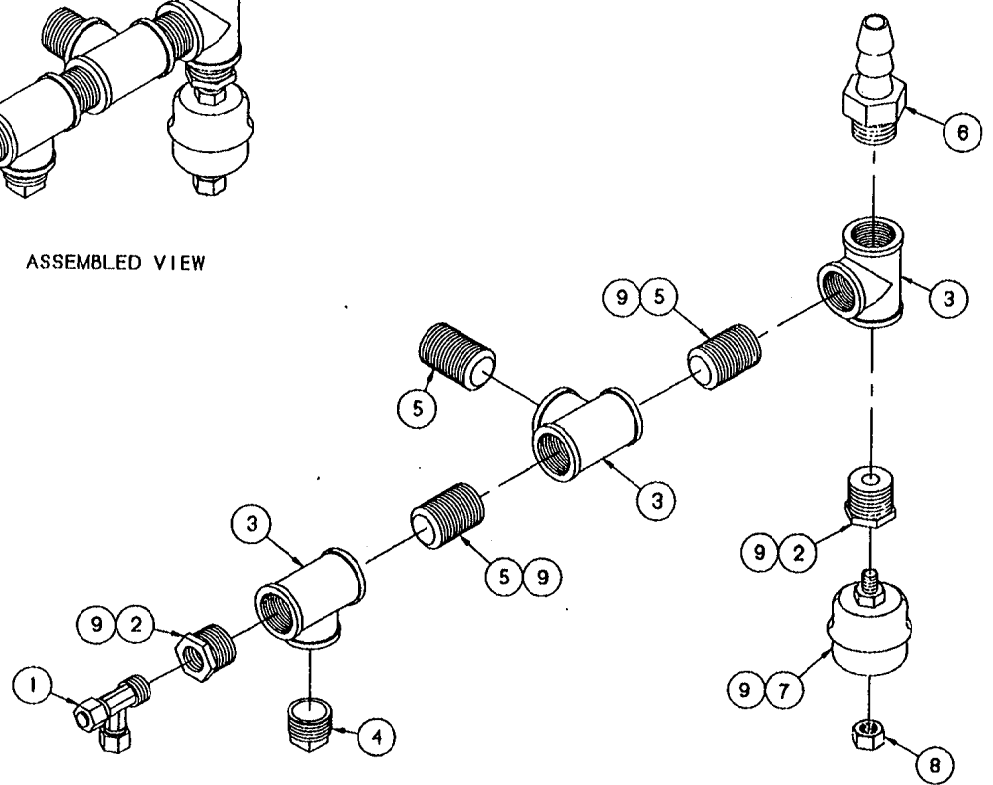

ITEM	QTY.	PART NO.	DESCRIPTION
9	A/R	00934	SEALANT, RECTORS SEAL
8	1	14661	NUT, COMPRESSION, 1/4 TUBE, BRASS
7	1	101207	TRAP, THERMOSTATIC, W/POL SEAT
6	1	08240	FITTING, HOSE BARB 3/4 HOSE X 3/4 MPT BRASS
5	3	14342	NIPPLE, 3/4 X CLOSE, BRASS
4	1	18807	PLUG, SQUARE HEAD, 3/4, BRASS
3	3	20206	TEE, 3/4 BRASS
2	2	02563	BUSHING, REDUCING, 3/4 X 1/4, BRASS
1	1	100883	FITTING, COMPR., TEE 3/8T X 3/8MPT X 3/8T

<b>TOLERANCES</b> <small>(UNLESS AS NOTED)</small>			
<b>CLEVELAND RANGE INC.</b> 1333 East 179th St. Cleveland, Ohio 44110-2574			
DECIMAL ± N/A	SCALE 1/2=1	DRAWN BY E. GRIVEAS	APPROVED BY NLT
ANGULAR ± N/A	TITLE STEAM OUTLET ASSEMBLY REV. BEND GEN., ELECTRIC		
CK	DATE 10-08-93	DRAWING NO. C - 428124	REV. -

NEXT ASS'Y: Df'D0001

THIS DESIGN DESCRIBES A PROPRIETARY ITEM AND IS THE PROPERTY OF CLEVELAND RANGE. THIS DRAWING IS NOT TO BE COPIED OR USED WITHOUT THE APPROVAL OF CLEVELAND RANGE.

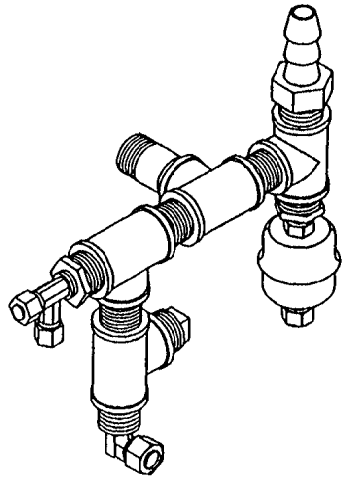

ASSEMBLED VIEW

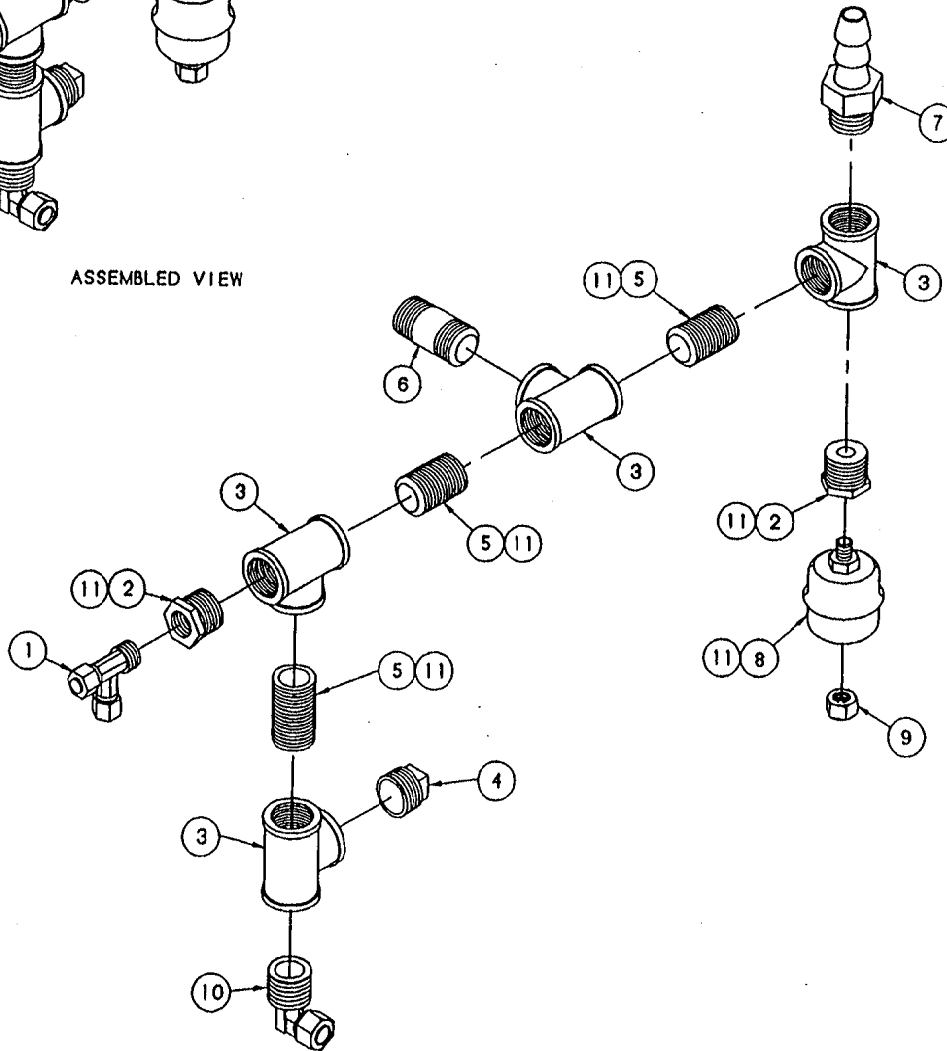

ITEM	QTY.	PART NO.	DESCRIPTION
11	A/R	00934	SEALANT, RECTORSEAL
10	1	08187	FITTING, COMPR., 90 DEG. 1/2T X 3/4MPT
9	1	14861	NUT, COMPRESSION, 1/4 TUBE, BRASS
8	1	101207	TRAP, THERMOSTATIC, 1/4" X 1/4"
7	1	06240	FITTING, HOSE BARB 3/4 HOSE X 3/4 MPT BRASS
6	1	14431	NIPLLE, 3/4 X 2, BRASS
5	3	14342	NIPLLE, 3/4 X CLOSE, BRASS
4	1	18807	PLUG, SQUARE HEAD, 3/4, BRASS
3	4	20206	TEE, 3/4 BRASS
2	2	02589	BUSHING, REDUCING, 3/4 X 1/4, BRASS
1	1	100893	FITTING, COMPR., TEE 3/8T X 3/8MPT X 3/8T

TOLERANCES (EXCEPT AS NOTED)			
<b>CLEVELAND RANGE INC.</b> 1333 East 179th St., Cleveland, Ohio 44110-2574			
DECIMAL ± N/A	SCALE 1/2=1	DRAWN BY D. DODSON	APPROVED BY NLT
TITLE STEAM OUTLET ASSY., 420KEM/420KGM REV. BEND GENERATOR			
DATE CK 2-03-94	DRAWING NO. C - 42 - 6		REV. -

THIS DESIGN DESCRIBES A PROPRIETARY ITEM AND IS THE PROPERTY OF CLEVELAND RANGE. THIS DRAWING IS NOT TO BE COPIED OR USED WITHOUT THE WRITTEN APPROVAL OF CLEVELAND RANGE.

NOTE: ROTATE VALVE ABOUT 45° FOR J PRESUURE BASES.

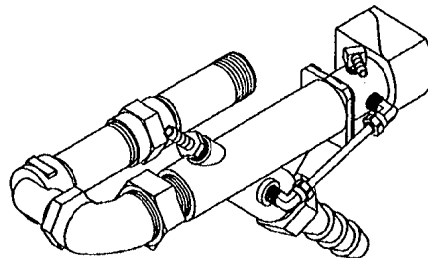
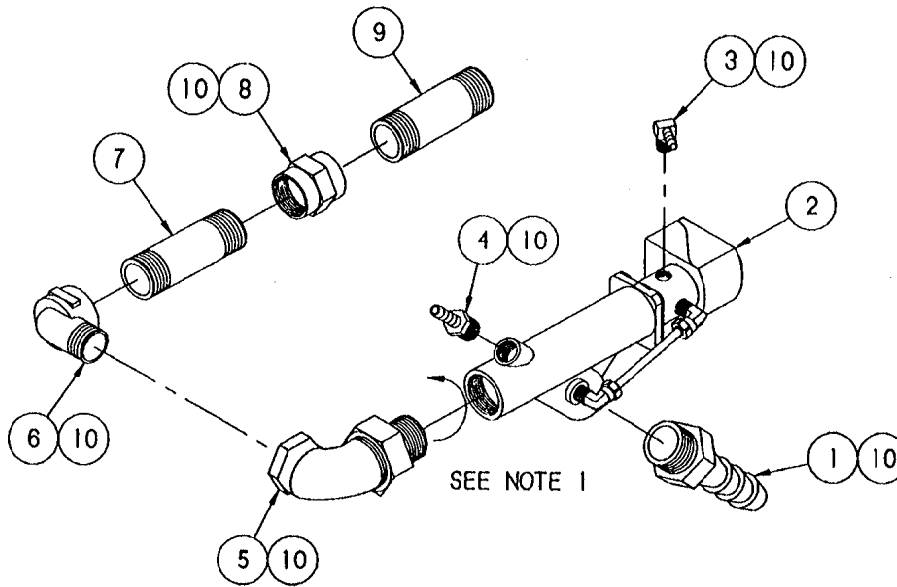

LET.	REVISIONS	DATE	BY
A	REMOVED P/N'S 03851, 14329 (2), 05284 ADDED 08241	3-27-92	SM
B	P/N 08240 WAS 08241, P/N 22244 WAS 22221, P/N 104381 WAS 08218, P/NS 105787, 14348 & 03812 ADDED, P/NS 14324, 02588, 20208, 14342, 03277 & 08323 OMITTED PER E.O. #C-2148	08-18-93	PJD

NO.	QTY.	PART NO.	DESCRIPTION
10		00934	SEALANT, RECTORSEAL
9	1	14495	NIPPLE, 3/4 NPT X 3", S/S
⚠	1	03812	COUPLING, FULL, 3/4, BRASS
⚠	1	14348	NIPPLE, 3/4 X 3, BRASS
6	1	05291	ELBOW, STREET, 3/4 X 90°, FORGED BRASS
5	1	05283	ELBOW, UNION RADIATOR, 3/4 X 90°
⚠	1	104381	FITTING, HOSE BARB, 1/4 H X 1/4 MPT
⚠	1	105787	FITTING, HOSE BARB, 1/4 H X 1/8 MPT 90°
⚠	1	22244	VALVE, SOLENOID, 1/2", 15 PSI
⚠	1	08240	FITTING, HOSE BARB, 3/4 H X 3/4 MPT

TOLERANCES (EXCEPT AS NOTED)		CLEVELAND RANGE INC.		
DECIMAL	SCALE	1333 East 179th St. Cleveland, Ohio 44110-2574		
± N/A	1/2±1	DRAWN BY	S. MILEWSKI	
ANGULAR	TITLE	APPROVED BY	MLT	
± N/A	PIPING ASSEMBLY, BLOWDOWN 24CEM, ELECTRIC "J's"	DATE	DRAWING NO.	REV.
CK	03-28-92	C - 40889		8

THIS DESIGN DESCRIBES A PROPRIETARY ITEM AND IS THE PROPERTY OF CLEVELAND RANGE. THIS DRAWING IS NOT TO BE COPIED OR USED WITHOUT THE APPROVAL OF CLEVELAND RANGE.

LET.	REVISIONS	DATE	BY
A	ADDED P/N'S 03818 & 08240	3-27-92	SM
B	ADDED P/N 19917 EO #C-2267	8-16-92	SM
C	P/N 18808 WAS 08208 PER E.O. #C-2448	8-22-93	PD

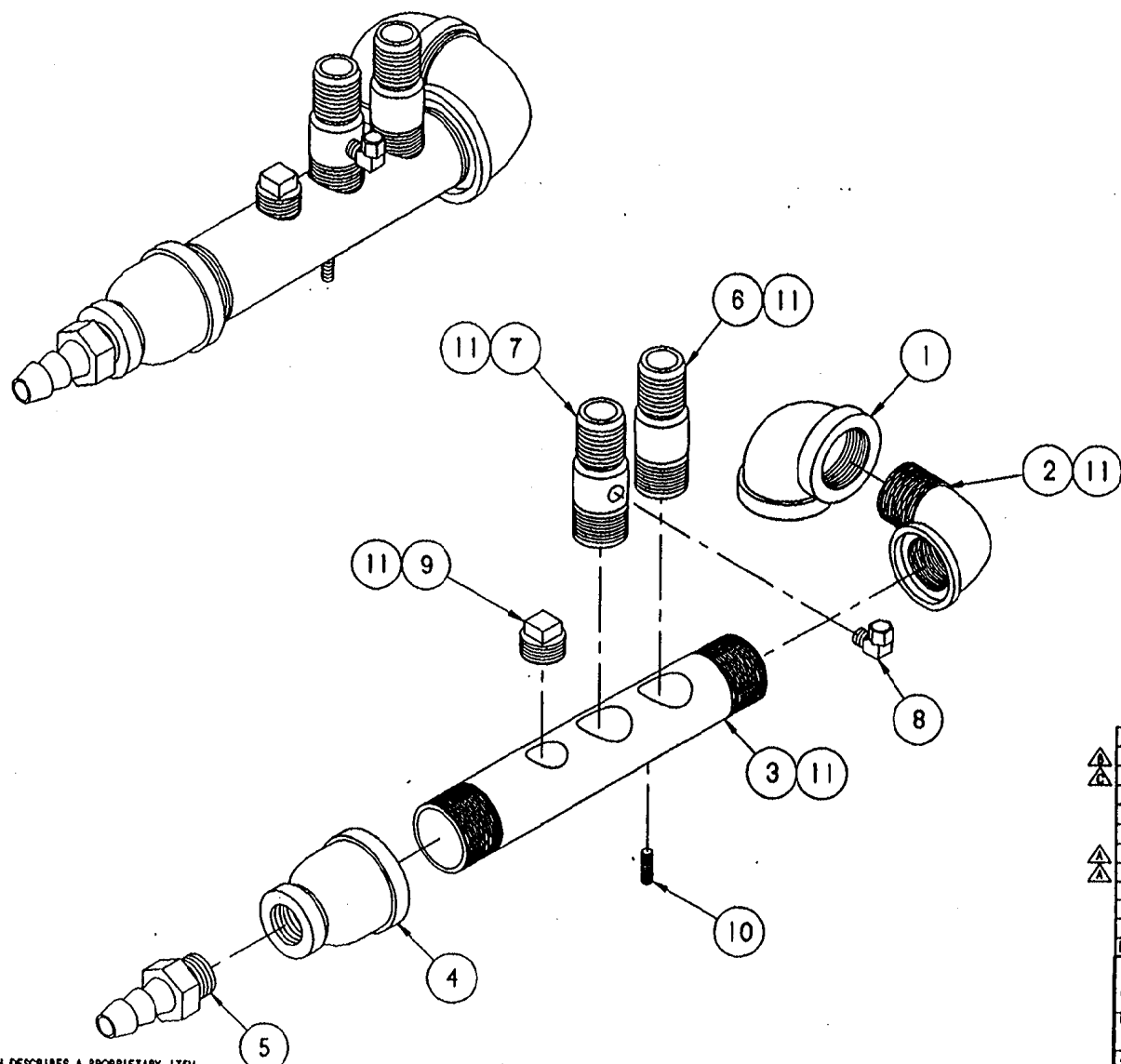

THIS DESIGN DESCRIBES A PROPRIETARY ITEM AND IS THE PROPERTY OF CLEVELAND RANGE. THIS DRAWING IS NOT TO BE COPIED OR USED WITHOUT THE APPROVAL OF CLEVELAND RANGE.

ITEM	QTY.	PART NO.	DESCRIPTION
11	A/R	00934	SEALANT, RECTORSEAL
10	1	19917	STUD, ARC WELD, 1/4-20 x .875, S/S
9	1	18808	PLUG, SQUARE HEAD, 3/4" PIPE, BLACK
8	1	08192	FITTING, COMP, 1/4 T x 1/8 MPT, 90°
7	1	585191	FITTING, HOSE BARB, 1" w/ 1/8" HOLE
6	1	14481	FITTING, HOSE BARB, 1" H x 1" NPT
5	1	08240	FITTING, HOSE BARB, 3/4 H x 3/4 MPT
4	1	03818	COUPLING, REDUC., 1-1/2 x 3/4, BLK
3	1	13252	MANIFOLD, DRAIN, 1-1/2, BLACK
2	1	05292	ELBOW, STREET, 1-1/2, 90°, BLACK
1	1	05238	ELBOW, 1-1/2 NPT, 90°, BLACK

<b>CLEVELAND RANGE INC.</b> 1333 East 179th St., Cleveland, Ohio 44110-2574			
TOLERANCES <small>(EXCEPT AS NOTED)</small>	SCALE 3/16"=1"	DRAWN BY S. MILEWSKI	APPROVED BY
DECIMAL ± N/A	TITLE DRAIN MANIFOLD ASSEMBLY 24CEM		
ANGULAR ± N/A	DATE 03-28-92	DRAWING NO. C - 42749	REV. C

LET.	REVISIONS	DATE	BY
-	PRODUCTION RELEASE E.O. 1C-1994	08-23-91	P.J.D.
A	P/N 14347 & 20205 OMITTED AND P/N 08240 WAS QTY. OF 2 PER E.O. 1C-2448	08-22-93	P.J.D.

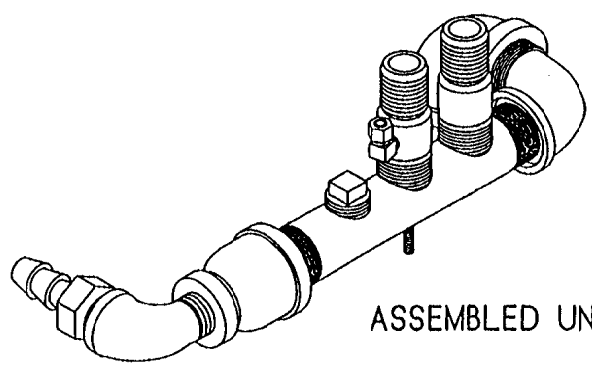
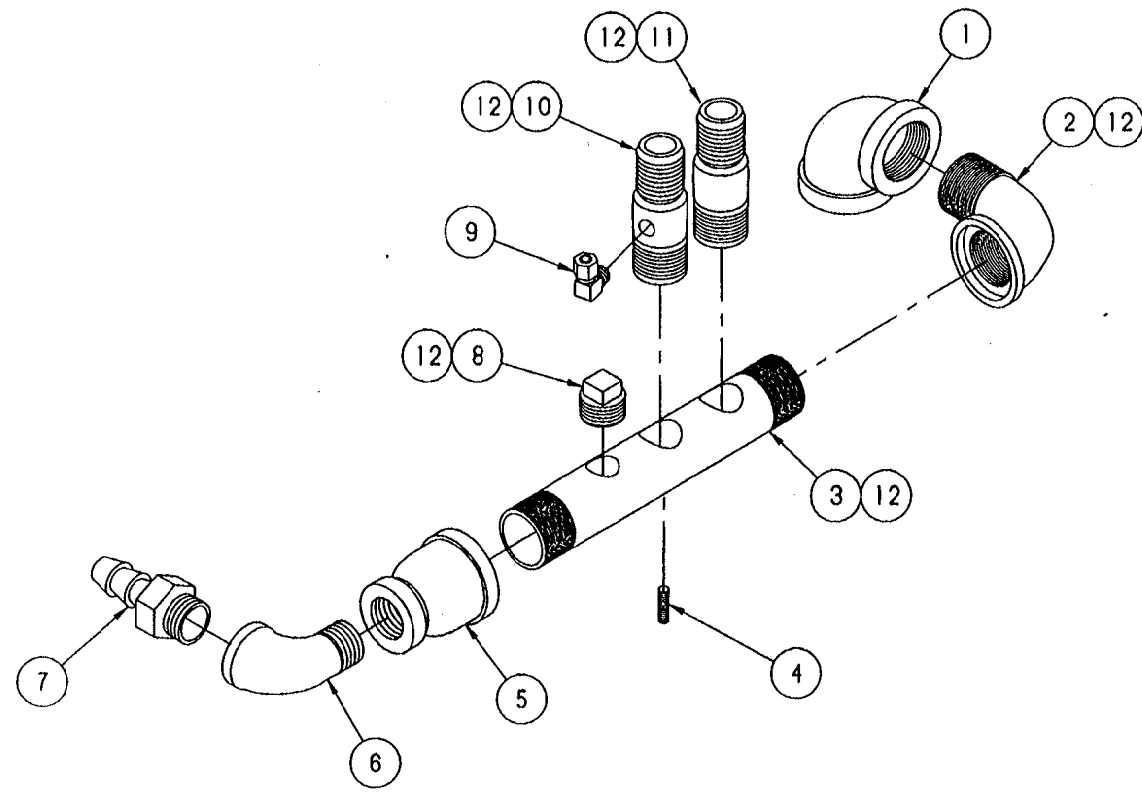

ASSEMBLED UNIT

ITEM	QTY.	PART NO.	DESCRIPTION
12	A/R	00934	SEALANT, RECTORSEAL
11	1	14481	FITTING, BARB 1" H X 1" MPT S/S
10	1	585191	FITTING, HOSE, DRAIN MANIFOLD W/ 1/8 HOLE
9	1	08192	FITTING, COMP. 1/4 T X 1/8 MPT 90°
8	1	18808	PLUG, SQ. HEAD, 3/4" PIPE, BLACK
7	1	08240	FITTING, HOSE BARB 3/4 H X 3/4 MPT
6	1	05259	ELBOW, STREET 3/4 X 90°, BLACK
5	1	03818	COUPLING, RED. 1-1/2 X 3/4, BLACK
4	1	19917	STUD, WELD 1/4-20 X 7/8, S/S
3	1	13252	MANIFOLD, DRAIN 1-1/2 NPT, BLACK
2	1	05292	ELBOW, STREET 1-1/2 NPT X 90° BLACK
1	1	05238	ELBOW, 1-1/2 NPT X 90°, BLACK

TOLERANCES (EXCEPT AS NOTED)		<b>CLEVELAND RANGE INC.</b> 1333 East 179th St. Cleveland, Ohio 44110-2574	
DECIMAL ± N/A	SCALE 1/2"	DRAWN BY P.J.D.	APPROVED BY
ANGULAR ± N/A	TITLE PIPING ASSEMBLY, DRAIN 38CGM/SM, 38CGM/LG, 38CEM, 24CSM, 38CSM		
CK	DATE 08-13-91	DRAWING NO. C - 42751	REV. A

THIS DESIGN DESCRIBES A PROPRIETARY ITEM AND IS THE PROPERTY OF CLEVELAND RANGE. THIS DRAWING IS NOT TO BE COPIED OR USED WITHOUT THE APPROVAL OF CLEVELAND RANGE.