



A **WELBILT** Company



## *INSTALLATION, OPERATION AND SERVICE MANUAL*



### **COOK TANK-**

MODEL: CT-600  
CT-1000  
CT-2000

### **CLEVELAND RANGE INC.**

1333 East 179th St.  
Cleveland, Ohio  
U.S.A. 44110  
Toll Free 1-800-338-2204

# **TABLE OF CONTENTS**

<b><i>Installation</i></b>	<i>General</i> . . . . .	1
	<i>Inspection</i> . . . . .	1
	<i>Shipping Damage Instruction</i> . . . . .	1
	<i>Installation</i> . . . . .	1
	<i>Electrical Service Connection</i> . . . . .	1
	<i>Wire Connection</i> . . . . .	1
	<i>Installation Check</i> . . . . .	1
	<i>Installation Drawing</i> . . . . .	2
<b><i>Operating Instructions</i></b>	<i>Operating Controls Drawing</i> . . . . .	3
	<i>Operating Instructions- Using MRC 7000 Chart Recorder</i> . . . . .	4
	<i>Typical Operating Sequences - Without Meat Probe</i> . . . . .	5
	- <i>Meat Probe Operation</i> . . . . .	5
<b><i>Cleaning Instructions</i></b>	<i>Care &amp; Cleaning</i> . . . . .	6
<b><i>Service Parts</i></b>	<i>Warranty</i> . . . . .	7
	<i>Control Console Components</i> . . . . .	7-8
	<i>Electrical Components</i> . . . . .	9
	<i>Motor/Fan Assembly</i> . . . . .	10
	<i>Miscellaneous Assemblies</i> . . . . .	11-12
	<i>Main Console Components</i> . . . . .	13-14
	<i>Spring Assist Hinge Assembly</i> . . . . .	15
<b><i>Maintenance</i></b>	<i>General Maintenance Instructions</i> . . . . .	16
	<i>Hinge Adjustment Instructions</i> . . . . .	16
	<i>Switch Configuration &amp; Disassembly</i> . . . . .	16
	<i>Solenoid Valve Maintenance</i> . . . . .	17-18
	<i>Motor Replacement Procedure</i> . . . . .	19
<b><i>Programming Instructions</i></b>	<i>MRC 7000 Enable Mode Procedure</i> . . . . .	20
	<i>MRC 7000 General Programming Instructions</i> . . . . .	21-22
<b><i>Wiring Diagram</i></b>	. . . . .	23

# INSTALLATION

## GENERAL

Installation of the Cook Tank must be accomplished by qualified installation personnel working to all applicable local and national codes. Improper installation of product could cause injury or damage.

This unit is built to comply with applicable standards for manufacturers. Included among those approval agencies are: UL, NSF, ASME/Ntl.Bd., CSA, ETL, CE, and others. Many local codes exist, and it is the responsibility of the owner/installer to comply with these codes.

## INSPECTION

Before uncrating, visually inspect the unit for evidence of damage during shipping. If damage is noticed, do not unpack the unit, follow shipping damage instructions.

## SHIPPING DAMAGE INSTRUCTIONS

If shipping damage to the unit is discovered or suspected, observe the following guidelines in preparing a shipping damage claim.

1. Write down a description of the damage or the reason for suspecting damage as soon as it is discovered. This will help in filling out the claim forms later. If possible, take a polaroid picture.
2. As soon as damage is discovered or suspected, notify the carrier that delivered the shipment.
3. Arrange for the carrier's representative to examine the damage.
4. Fill out all carrier claims forms and have the examining carrier sign and date each form. .

## INSTALLATION

1. Refer to the INSTALLATION DRAWING for the clearance requirements, in order to determine the location of the unit
2. Check the load weight of your unit and the maximum load the floor can carry to insure the unit can be safely positioned.
3. Remove the crating material and position the unit.
4. Remove the console side and back panel.
5. Connect plumbing to unit. Labels have been attached to each termination point. If a label is missing refer to the specification sheet.

**NOTE:** The plumbing leading to this unit must be sized correctly in order to have a sufficient water and steam supply for correct operation.

## ELECTRICAL SERVICE CONNECTION

Install in accordance with local codes and/or the National Electric Code ANSI/NFPA No. 70-1990 (USA) or the Canadian Electrical Code CSA standard C22.1 (Canada). A separate fused disconnect switch must be installed and electrically grounded by the installer.

The electrical supply must match the power requirements specified on the units rating plate. The copper wiring must be adequate to carry the required current at the rated voltage. Refer to the specification sheet for electrical specifications.

## WIRE CONNECTION

1. Remove the four screws holding the chart recorder in place.
  2. Remove chart recorder.
  3. Feed correctly sized permanent copper wire through the hole in the back of the component compartment.
  4. Connect the wire to the four connection terminal block.
  5. Connect the ground wire to the ground lug.
- NOTE:** Insure the motor turns in the direction of the arrow. Clockwise from fan side, or counter clockwise from motor end.
6. Feed the two control wires into the component compartment and attach to the two connection terminal block.
  7. Replace chart recorder.
  8. Replace side and rear panels.

## INSTALLATION CHECK

Although the unit has been thoroughly tested in the factory, and a factory representative will generally perform a start up inspection. The installer is still responsible for ensuring the proper operation of the unit once installed. Following are a few basic functions that can be checked easily.

1. Supply power to the unit is correct and separately fused. When turned on the green light will illuminate.
2. Check all plumbing connections for correct termination.
3. Check that the unit is level.
4. Check that the fan motor rotates in correct direction.

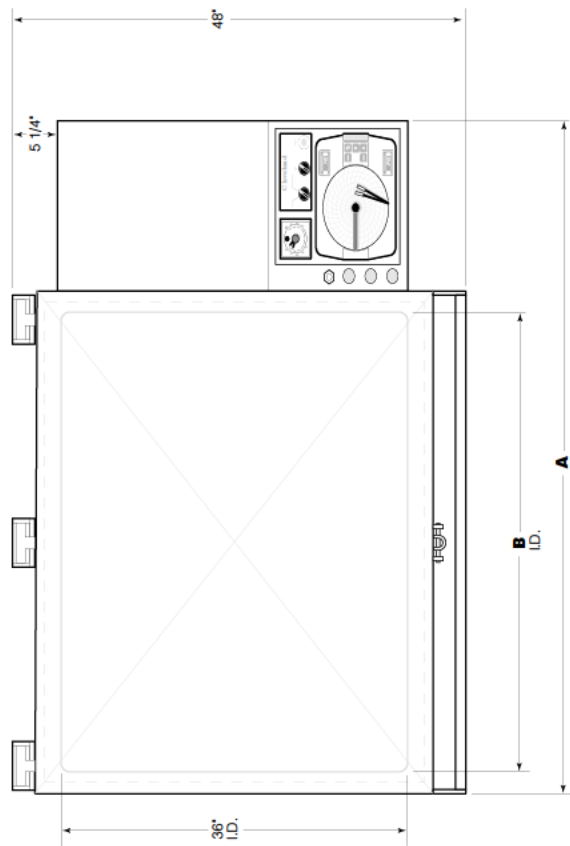

**Clearance**

RIGHT = 12"  
LEFT = 0"  
REAR = 18"

**Legend**

- 2" NPT. CHILLED WATER RETURN
- 2" NPT. CHILLED WATER IN
- D<sub>1</sub> 2" NPT. DRAIN
- ⊕ 1" NPT. STEAM IN
- 1/2" NPT. CONDENSATE RETURN
- H 1" NPT. HOT WATER IN
- C 1" NPT. COLD WATER IN
- ⚡ ELECTRICAL SUPPLY: 120/208v, 14 amps., or 220/380v., 10amps. or 240/415v., 10amps.
- D<sub>2</sub> OVERFLOW DRAIN - 1 3/4" I.D. FLEXIBLE HOSE
- PIPE TERMINATION
- H C Supplied with factory installed shut-off valves.

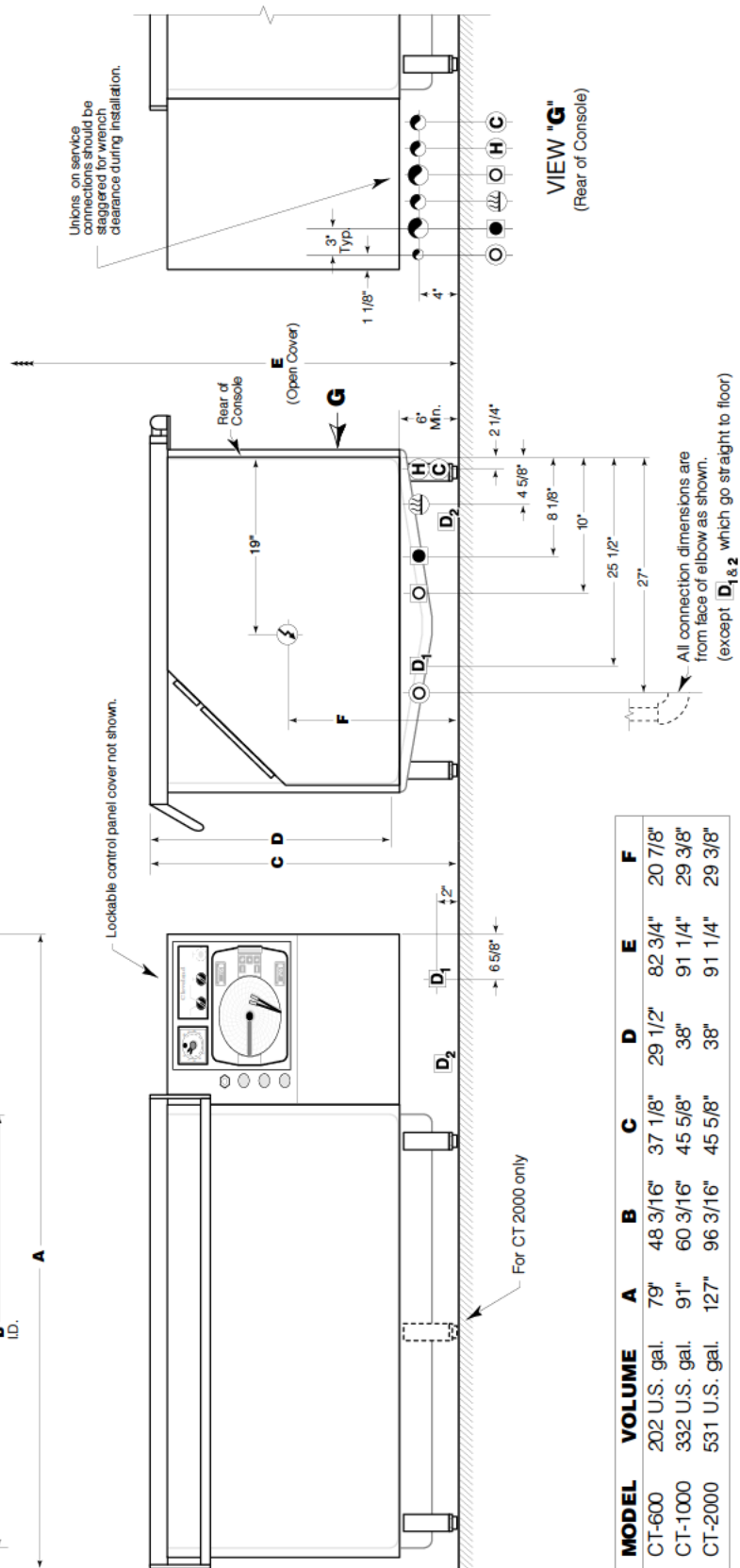

MODEL	VOLUME	A	B	C	D	E	F
CT-600	202 U.S. gal.	79"	48 3/16"	37 1/8"	29 1/2"	82 3/4"	20 7/8"
CT-1000	332 U.S. gal.	91"	60 3/16"	45 5/8"	38"	91 1/4"	29 3/8"
CT-2000	531 U.S. gal.	127"	96 3/16"	45 5/8"	38"	91 1/4"	29 3/8"

# OPERATING INSTRUCTIONS

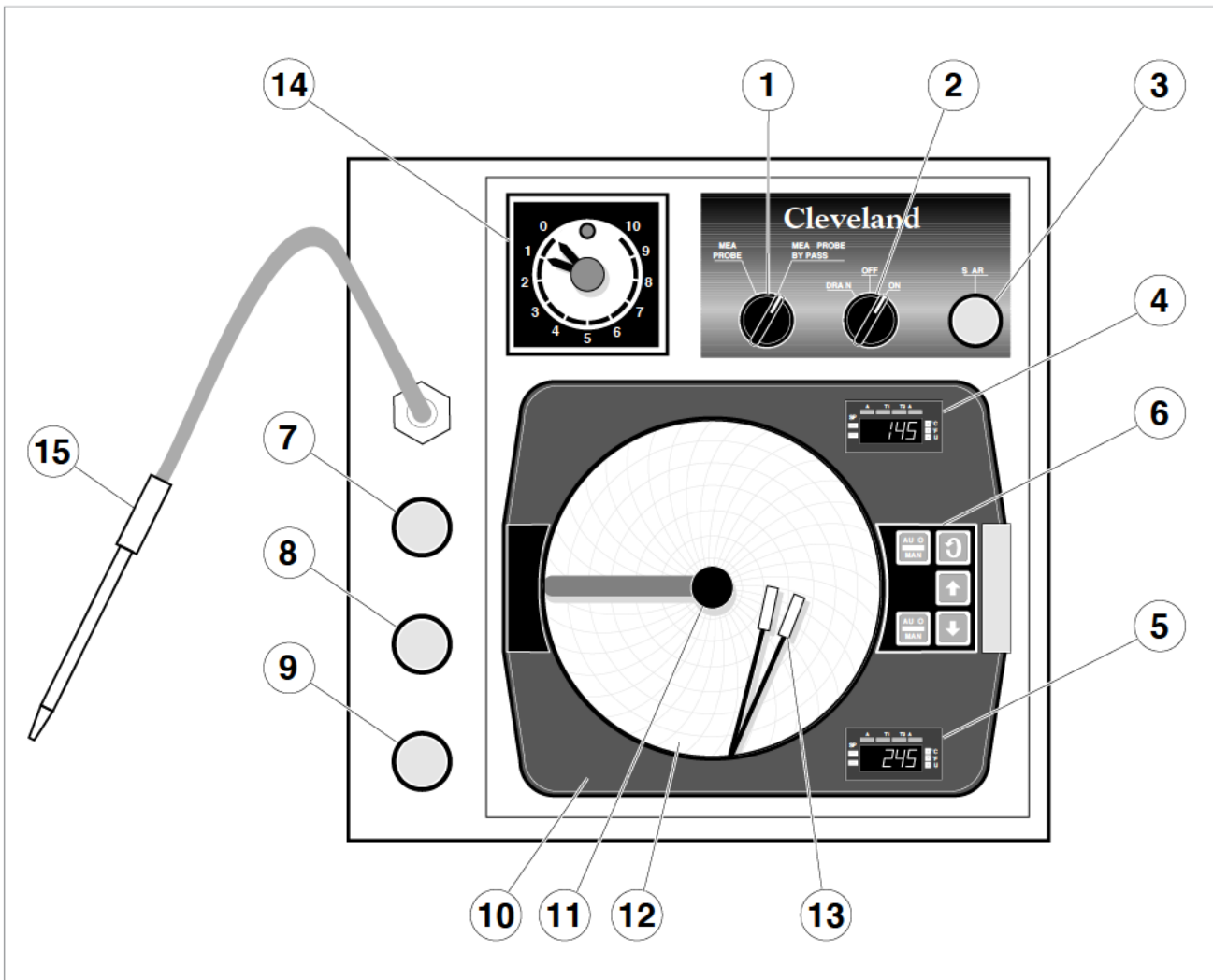

Operating Controls Drawing

ITEM #	DESCRIPTION	FUNCTION
1.	By-Pass Switch	Tells chart recorder if meat probe is functional.
2.	Power Switch	Turns power ON/OFF, turns drain ON.
3.	Start Button	Push to start the system.
4.	Meat Probe Switch	Used to set the product temperature.
5.	Water Bath Switch	Used to set the water bath temperature.
6.	Keypad	Used to program time/temperatures.
7.	Pilot Light (green)	Power indicator.
8.	Pilot Light (red)	Heating indicator.
9.	Pilot Light (blue)	Cooling indicator.
10.	MRC 7000 Chart Recorder	Time/Temperature chart recorder.
11.	Locking Arm	Holds chart paper in place.
12.	Chart Paper	Lined for time/temperature recording.
13.	Pens	Records temperature on chart paper.
14.	Timer	Set to produce desired cooking time.
15.	Meat Probe	Senses product temperature



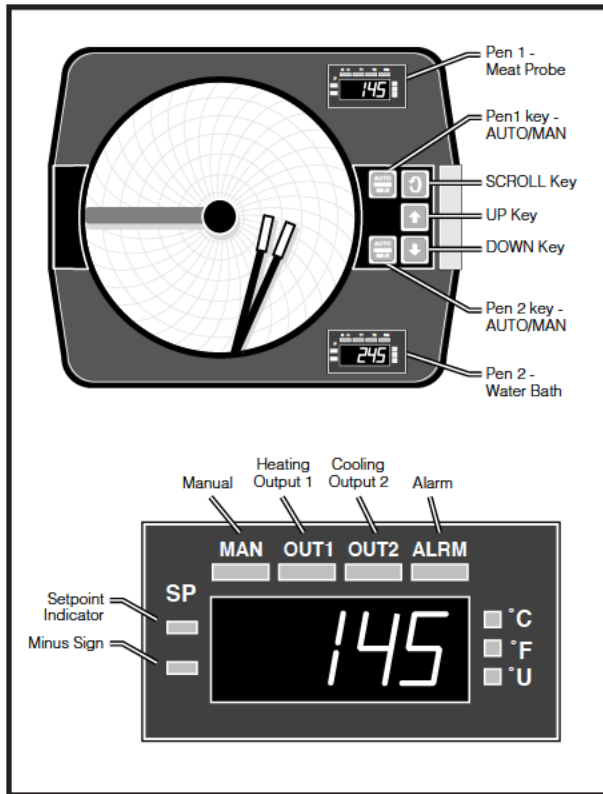

MRC 7000 Controls Drawing (2 pen)

## OPERATING INSTRUCTIONS USING MRC 7000 CHART RECORDER

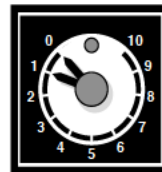
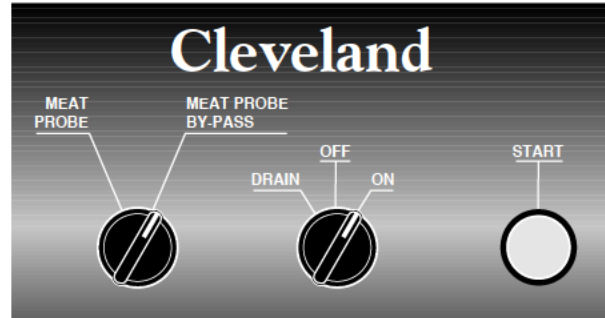

Setting must be done in this order:

**1.** Set timer by rotating dial.

**Note:** Turn past one hour and then set time - a minimum of 15 minutes is required for cook tank to work correctly.

- 2.** Turn right hand switch to "ON".
- 3.** Set left hand switch to "MEAT PROBE" or "MEAT PROBE BY-PASS".
- 4.** Set temperatures on chart recorder.

### A. WATER BATH TEMPERATURE:

- 1.** Push and release key "↓".

**Note:** A green light will come on in the bottom display window underneath the S.P. (set point) symbol. This temperature can be altered as long as this light is on.

- 2.** Push key "↑" or "↓" to set temperature.

### B. MEAT PROBE TEMPERATURE:

- 1.** Push and release key "↑".

**NOTE:** A green light will come on in the top display window underneath the S.P. (set point) symbol. This temperature can be altered as long as this light is on.

- 2.** Push key "↑" or "↓" to set temperature.

**Note:** Once MRC 7000 is turned on, it will remain on even when the power switch is turned off. Steps **D** and **E** are only necessary when the display is alternating between "OFF" and the temperature display.

To turn on:

- D.** Push function key "⌂" until "Ctrl" is displayed.

- E.** Push and release the key "↓".

- 5.** Push "START" button.

## TYPICAL OPERATING SEQUENCES

**NOTE:** See page 3 for part number designations.

### WITHOUT MEAT PROBE

**NOTE:** The unit can be checked for correct operation without product.

1. Date and label a new sheet of Chart Paper **(12)** and install in MRC 7000 Chart Recorder **(10)**.
2. Load the unit with product.
3. Set the total operating time by turning the dial on Timer **(14)** clockwise.
4. Turn Power Switch **(2)** to "ON".
5. Turn By-Pass Switch **(1)** to "MEAT PROBE BY-PASS".
6. Set the desired water bath temperature by pushing the pin wheels on the Water Bath Switches **(5)**.

**NOTE:** The time you set on the timer is the total run time including the time it takes to fill the tank.

7. Push "START" Button **(3)**.

### **RESULTS:**

- ⇒ Green Pilot Light **(7)** will illuminate.
- ⇒ Timer **(14)** will start timing down.
- ⇒ Hot water will enter tank.
- ⇒ Heating system will activate and Red Pilot Light **(8)** will energize.
- ⇒ Water level will rise and circulation fan will activate.
- ⇒ Hot water will stop entering tank when water level is within 1 to 2 inches from the top.
- ⇒ Water temperature will rise until it reaches the water bath temperature setting.
- ⇒ Water temperature will be maintained until Timer **(14)** times out.
- ⇒ Timer **(14)** times out.
- ⇒ Heating system is shut off. Red Pilot Light **(8)** turns off.
- ⇒ Drain opens and water drains out.
- ⇒ Drain closes and cold water begins to fill tank. Blue Pilot Light **(9)** is illuminated.
- ⇒ Water level rises and circulation fan activates.

⇒ Circulation pump for ice water activates.

**NOTE:** The tank will continue in the cooling mode until the Power Switch **(2)** is turned to "OFF".

### DRAINING UNIT

1. Turn the Power Switch **(2)** to "OFF". This will stop the cold water circulation pump and the agitator fan. The unit will not drain.
2. Turn the Power Switch **(2)** to "DRAIN". The unit will drain.

### MEAT PROBE OPERATION

1. Turn dial on Timer **(14)** to desired soak time.
2. Turn Power Switch **(2)** to "ON".

**NOTE:** Meat probe cooking can be tested using an apple for product.

3. Turn By-Pass Switch **(1)** to "MEAT PROBE".

**NOTE:** Soak time is the amount of time the product will remain at the meat probe temperature setting once it has been reached.

4. Set the meat probe temperature by pushing the pin wheels on the Meat Probe Switches **(4)**.
5. Set water bath temperature by pushing the pin wheels on the Water Bath Switches **(5)**. This should be 5 to 10 degrees higher than the meat probe temperature setting.
6. Date and label a new sheet of Chart Paper **(12)** and install in MRC 7000 Chart Recorder **(10)**.
7. Insert meat probe tip through casing into centre of product.
8. In case this bag in a second bag. Remove as much air as possible and tie the bag around the probe with a tie wrap.
9. Load tank with product. Use adjustable dividers as required in the baskets to prevent excessive movement of product.
11. Push the Start Button **(3)**.

### **RESULTS:**

The steps the tank will go through are the same as in the meat probe by-pass mode, with the following exceptions.

- ⇒ The Timer **(14)** will not start timing down until the meat probe set temperature has been reached.
- ⇒ The MRC 7000 Chart Recorder **(10)** will record two temperatures.

# ***CLEANING INSTRUCTIONS***

## **CARE AND CLEANING**

The cook tank must be cleaned regularly to maintain its efficient cooking performance, and to ensure its' continued safe reliable operation.

**WARNING:** Do not use chloride based cleaners.

- 1.** Prepare a warm solution of water and mild detergent.
- 2.** Using a nylon brush, clean the inside and outside of the tank.
- 3.** Insure you have removed any grease or dirt build-up from the two probes inside the tank. One probe is located in the recess at the top right rear of the tank. The other two are located behind the agitator fan.
- 4.** Clean the baskets and dividers using the same mild detergent

**NOTE:** For more difficult cleaning applications one of the following can be used: alcohol, baking soda, vinegar, or a solution of ammonia in water. Avoid the use of chloride cleansers, which may damage the Cook Tank's stainless steel surface.

**WARNING:** Steel wool should never be used for cleaning the cooking chamber of the Cook Tank. Particles of steel wool become embedded in the cooking surface and rust, which may corrode the stainless steel.



# SERVICE PARTS

## WARRANTY

Our Company supports a worldwide network of Maintenance and Repair Centers. Contact your nearest Maintenance and Repair Centre for replacement parts, service, or information regarding the proper maintenance and repair of your cooking equipment.



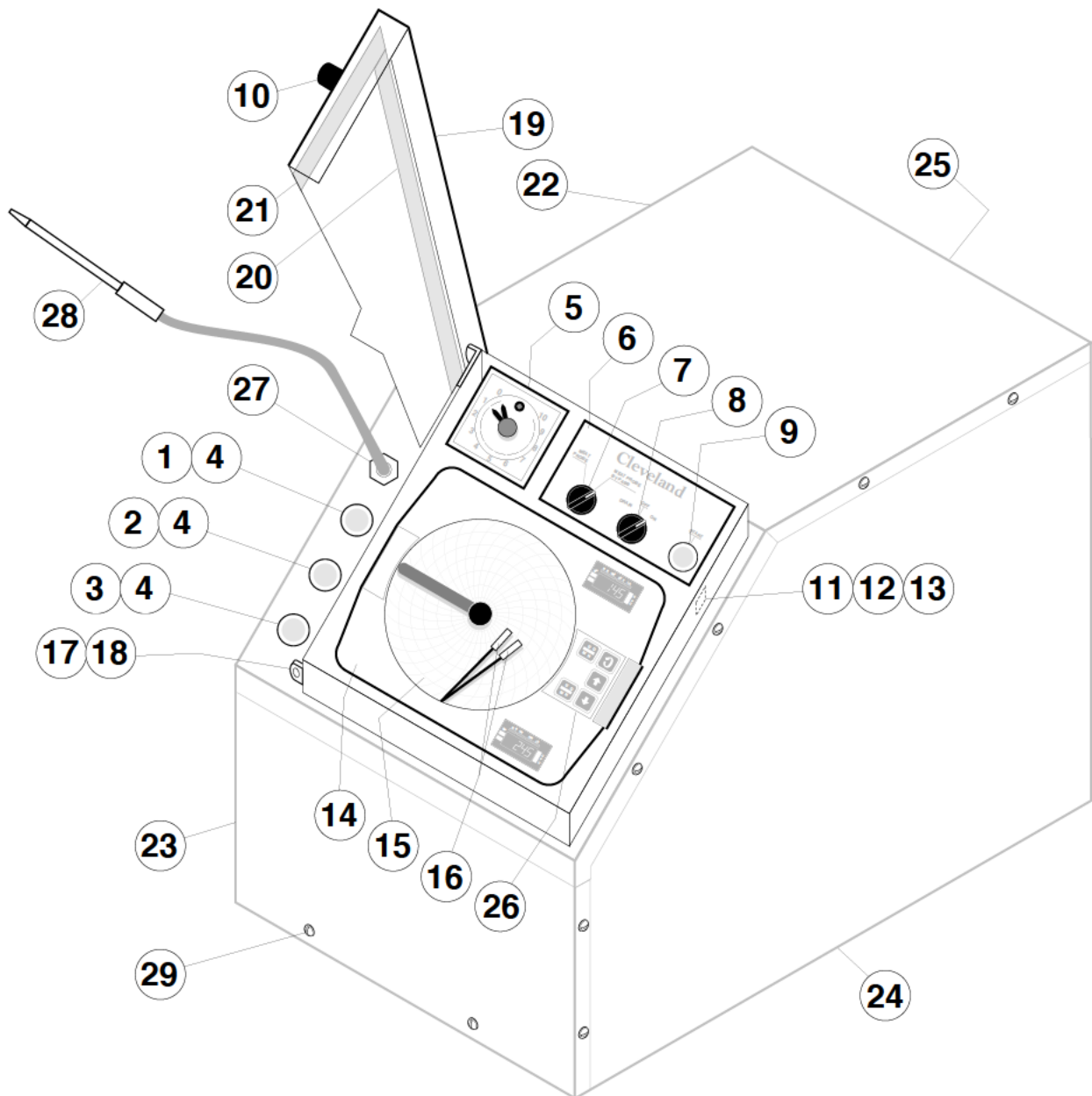

In order to preserve the various agency safety certification (UL, NSF, ASME/Ntl. Bd., etc.), only factory-supplied replacement parts should be used. The use of other than factory supplied replacement parts will void warranty.

---

## CONTROL CONSOLE

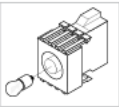

# CONTROL CONSOLE

ITEM NO.	PART NO.	DESCRIPTION	QTY.
1.	KE53191-2	 Green Pilot Light Lens . . . . .	1
2.	KE53191	 Red Pilot Light Lens . . . . .	1
3.	KE53191-3	 Blue Pilot Light Lens . . . . .	1
4.	KE53192	 Transformer, c/w bulb . . . . .	1
	SE50440	 Bulb . . . . .	1
5.	CT50079	Timer . . . . .	1
6.	CT50072	Control Label . . . . .	1
7.	KE01808	* Switch Assembly, ON/OFF . . . . .	1
8.	KE01809	* Switch Assembly, ON/OFF/ON . . . . .	1
9.	KE01813	* Push Button, ON/OFF . . . . .	1
<b>*NOTE:</b> Requires Contactor Cartridge KE53138-1, see SWITCH CONFIGURATION & DISASSEMBLY (page 18).			
10.	CT50115	Keylatch . . . . .	1
11.	FA11052	Machine Screw, #6-32 x 1/4" lg. . . . .	2
12.	FA21002	Hex Nut, #6-32 . . . . .	2
13.	FA32004	Tooth Lockwasher #6-32 . . . . .	2
14.	KE53136-3	Chart Recorder, 2 pen . . . . .	1
15.	SE50378	Chart Paper, 30-230° F, 24 hr. (pkg. 100) . . . . .	1
	SE50379	Chart Paper, 0-1000° C, 24 hr. (pkg. 100)	
16.	SE50354	Pen Tip, red (pkg. 5) . . . . .	1
	SE50355	Pen Tip, green (pkg. 5) . . . . .	1
17.	CT50075	Control Cover Hinge . . . . .	2
18.	FA11091	Binding Heat Screw, #8-32 x 3/8" lg. . . . .	4
19.	CT00026	Control Cover Assembly . . . . .	1
20.	CT50234	Control Cover Gasket (short) . . . . .	2
21.	CT50233	Control Cover Gasket (long) . . . . .	2
22.	CT00025	Console Cover Top . . . . .	1
23.	CT00029	Console Front Panel (CT-600) . . . . .	1
	CT00030	Console Front Panel (CT-1000 and CT-2000) . . . . .	1
24.	CT50043	Console Side Panel (CT-600) . . . . .	1
	CT50044	Console Side Panel (CT-1000 and CT-2000) . . . . .	1
25.	CT50113	Console Back Panel (CT-600) . . . . .	1
	CT50114	Console Back Panel (CT-1000 and CT-2000) . . . . .	1
26.	SE50439-3	Keypad, complete overlay . . . . .	1
27.	KE54721-1	Cord Connector . . . . .	1
28.	CT50022-1	Meat Probe . . . . .	1
29.	FA11135	Screws, #10-24 x 1/2" lg. . . . .	16

# ELECTRICAL COMPONENTS

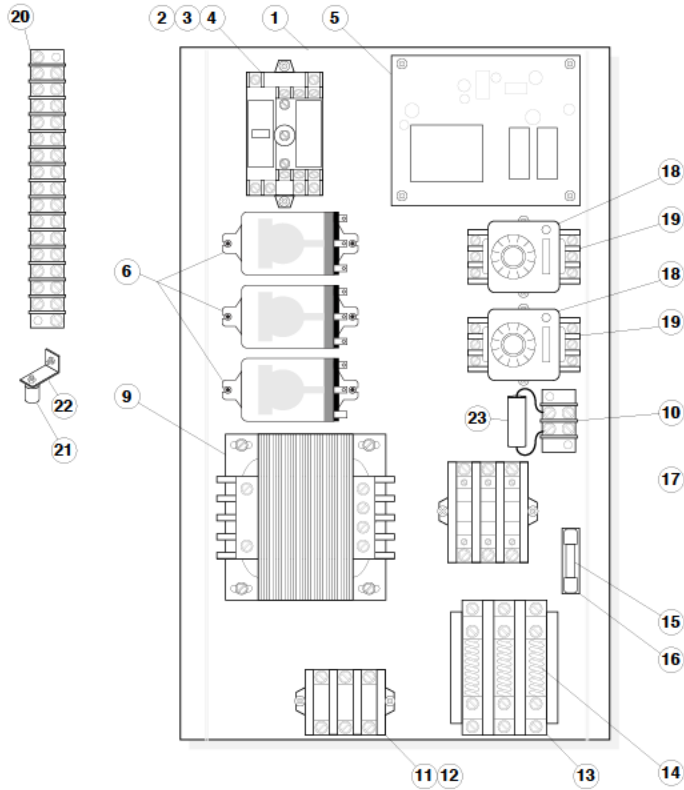

ITEM NO.	PART NO.	DESCRIPTION	QTY.
1.	KE50343-13	Mounting Plate	1
2.	CT50088	Relay, Latch	1
3.	CT50170	Mechanical Latch	1
4.	CT50123	Latch Relay Switch	1
5.	CT00034	Circuit Board Assembly for Water Level	1
6.	KE50753-10	Relay	3
9.		<b>Transformer</b>	1
	KE53838-2	200, 208, 220, 240, 380, 415, 440 & 480 volt	
	KE53838-4	600 volt	
10.	SK50370	Terminal Block	2
11.	SK50054-1	Terminal Block End	1
12.	SK50055-1	Terminal Block Section	3
13.	KE51982	Thermal Overload Relay	1
14.		<b>Heater for Thermal Overload</b>	3
	KE52055	200, 208, 220, 240, 380 & 415 volt	
	KE52051	440, 480 volt	
15.	SK50445	Fuse, 3 amp	1
16.	KE51139	Fuse Holder	1
17.	SK50224	Contactor	1
18.	CT50080	Time Delay	2
19.	CT50081	Socket, Time Delay	2
20.	KE52106	Terminal Block, 15 terminal	1
21.	KE52835	Bracket for Thermostat	1
22.	KE52710	Thermostat	1
23.	KE52709	Ambient Heater Assembly	1

# MOTOR/FAN ASSEMBLY

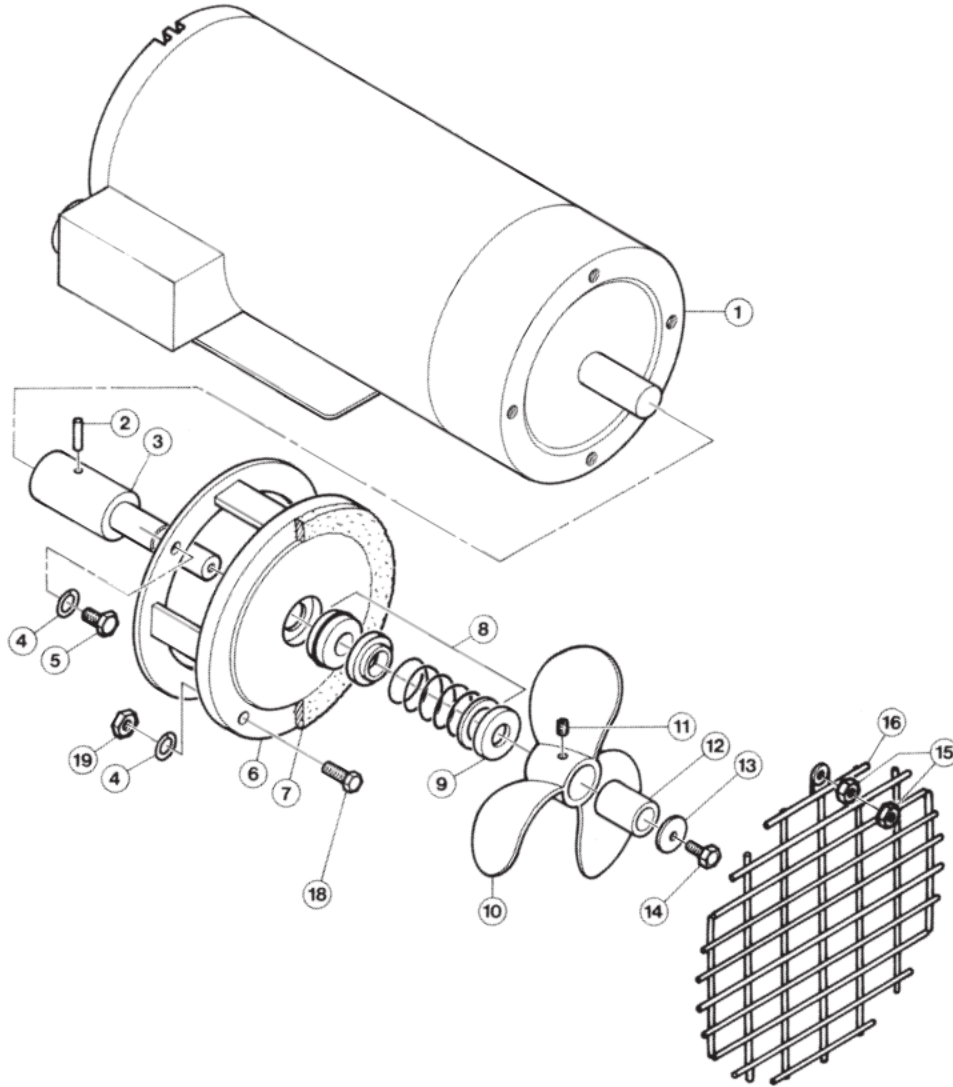

ITEM NO.	PART NO.	DESCRIPTION	QTY.
1.	KE51875	Motor, 208-240v, 460v .....	1
2.	CT50020	Taper Pin .....	1
3.	CT50011	Shaft Extension .....	1
4.	FA31031	Lock Washer .....	4
5.	FA11384	Hex Cap Screw .....	4
6.	CT00006	Motor/Fan Housing .....	1
7.	CT50014	Seal .....	1
8.	CT50019	Rotary Seal .....	1
9.	CT50010	Retaining Ring .....	1
10.	CT50021	Propeller, 6" (for CT-600 and CT-1000) .....	1
	CT500211	Propeller, 7" (for CT-2000) .....	1
11.		Allen Screw .....	1
12.	CT50012	Fan Shaft .....	1
13.	CT50013	Washer .....	1
14.	FA11256	Hex Cap Screw .....	1
15.	FA21024	Nut .....	1
16.	CT00041	Screen .....	1

# MISCELLANEOUS ASSEMBLIES

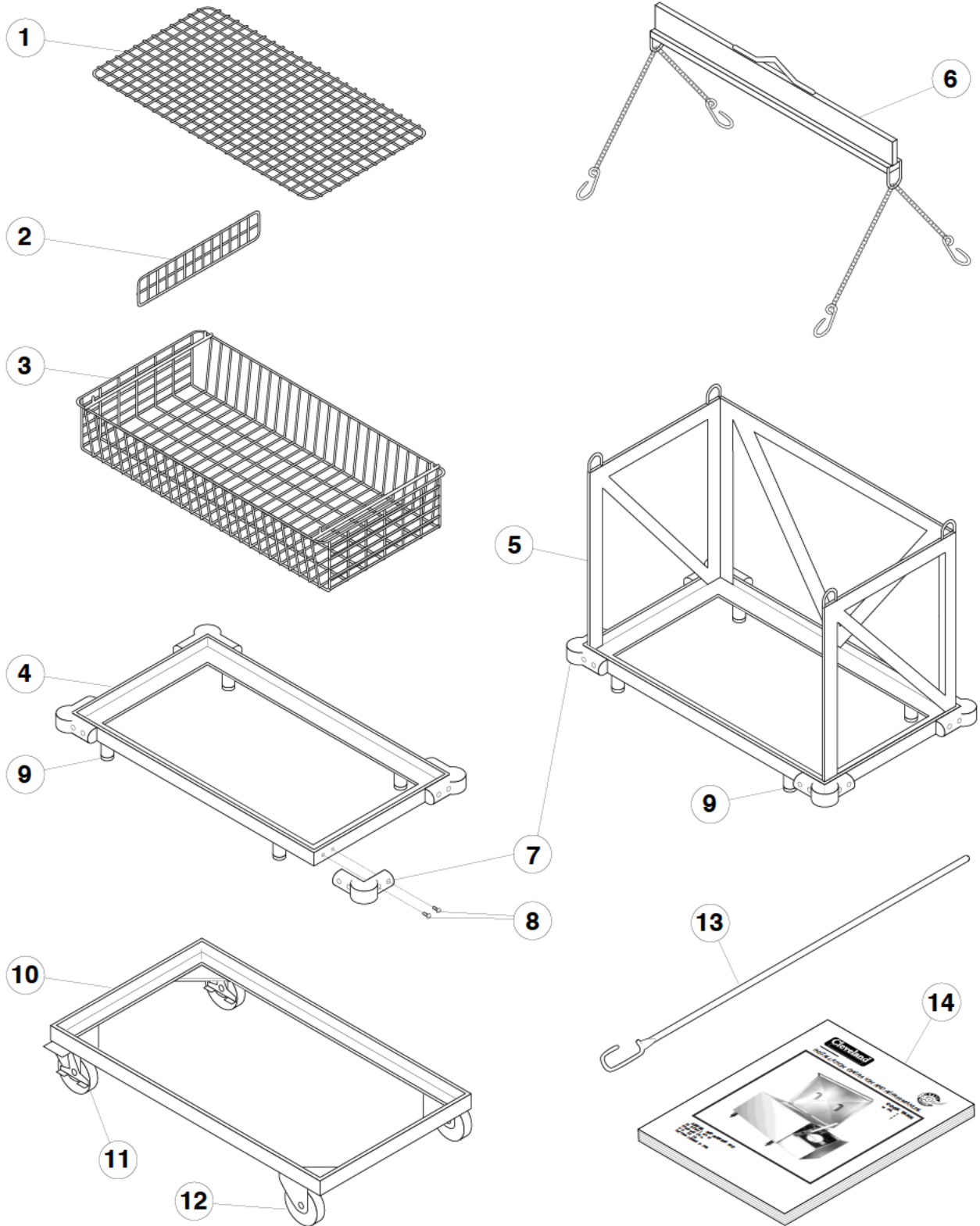

# MISCELLANEOUS ASSEMBLIES

<b>ITEM NO.</b>	<b>PART NO.</b>	<b>DESCRIPTION</b>	<b>QTY.</b>
1.	CT00019	Hold Down Screen	CT-600 .....1
	CT00020		CT-1000 .....1
	CT00019		CT-2000 .....2
2.	CT00021	Basket Divider	CT-600 .....16
	CT000211		CT-1000 .....25
	CT000211		CT-2000 .....40
3.	CT00010	Basket	CT-600 .....4
	CT00011		CT-1000 .....5
	CT000111		CT-2000 .....10
4.	CT00014	Basket Carrier (includes items 7,8 & 9)	CT-600 .....1
5.	CT00015	Basket Carrier c/w Lifting Bar Assembly (includes items 6,7,8 & 9)	CT-600 (optional) .....1
	CT000151		CT-1000 (standard) .....1
	CT000152		CT-2000 (standard) .....2
6.	CT00016	Lifting Bar Assembly	CT-600/2000 (optional) .....1
	CT00017		CT-1000 (optional) .....
7.	CT50227	Bumper Guard	per Basket Carrier .....4
8.	FA11126	Screw, #10-32 x 3/4" lg.	per Bumper Guard .....4
9.	CT50229	Foot	per Basket Carrier .....4
10.	CT00051	Cart	CT-600/2000 (optional) .....1
	CT00052		CT-1000 (optional) .....1
11.	KE521321	Caster, with brake	per Cart .....2
12.	KE52132	Caster, without brake	per Cart .....2
13.	CT00046	Cover Pull Down Handle	.....1
14.	SE95024 rev. 2	Service Manual	.....1



# MAIN CONSOLE COMPONENTS

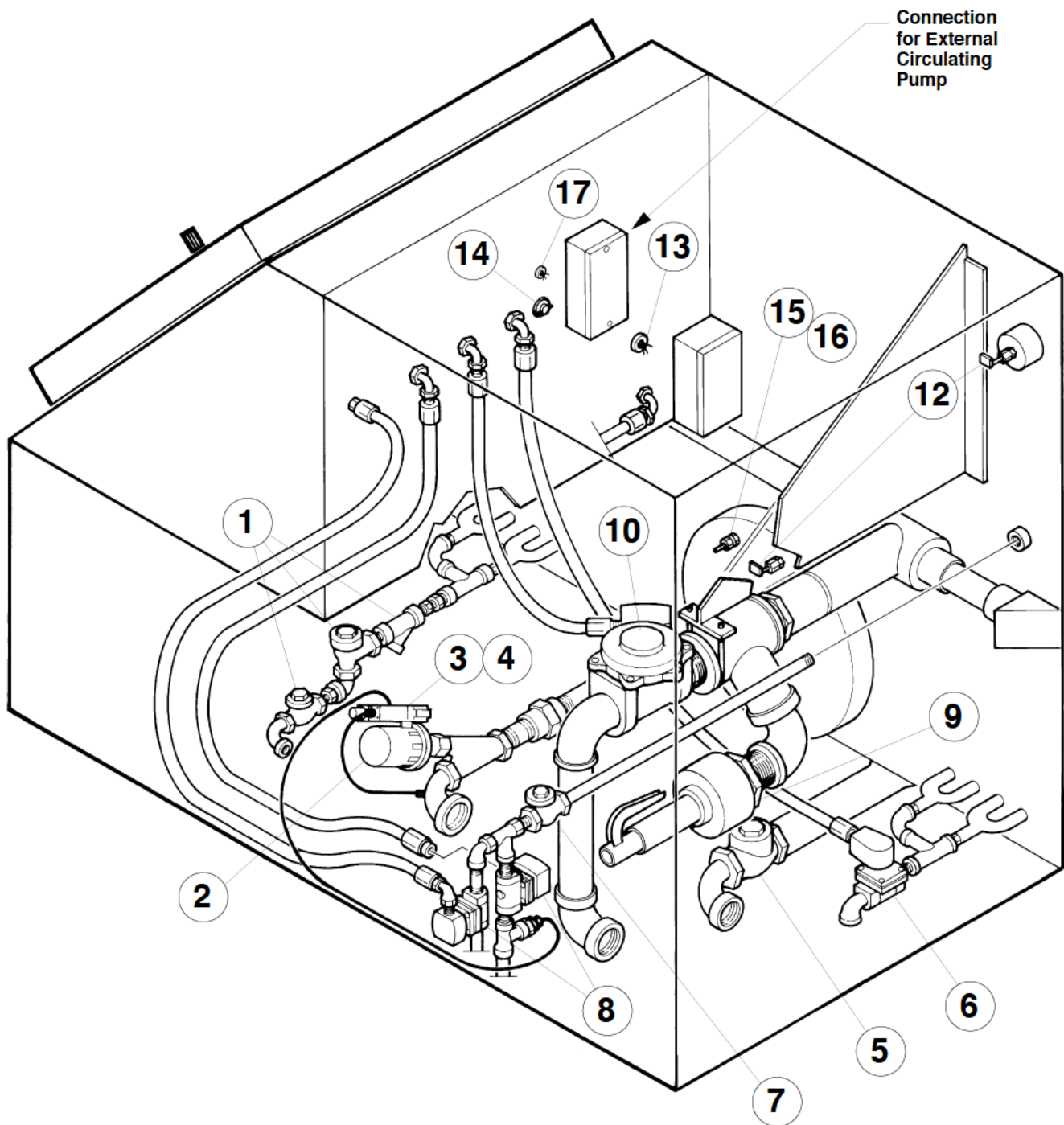

**MAIN CONSOLE COMPONENTS**

ITEM NO.	PART NO.	DESCRIPTION	QTY.
1.	SCK-3	Steam Control Kit . . . . .	1
2.	CT50276-1	Solenoid Valve, 2" (used after to January 97) . . . . .	1
	CT50276	Solenoid Valve, 2" (used prior January 97) . . . . .	1
3.	CT50179-1	Pilot Valve, for Solenoid Valve c/w Socket (used after to January 97) . . . . .	1
	CT50179	Pilot Valve, for Solenoid Valve (used prior to January 97) . . . . .	1
4.	CT50180	Socket, for Pilot Valve . . . . .	1
5.	CT50183	Check Valve, 2" . . . . .	1
6.	KE54834-7	* Solenoid Valve, 1" . . . . .	1
	SE50403	Solenoid Valve Rebuilt Kit	
	SE50404	Solenoid Valve Replacement Coil	
7.	CT50247	Check Valve . . . . .	1
8.	KE54834-6	* Solenoid Valve, 1" . . . . .	2
	SE50402	Solenoid Valve Rebuilt Kit	
	SE50401	Solenoid Valve Replacement Coil	
9.	CT50181-1	Safety Valve, 45 psi . . . . .	1
	CT50181-2	Safety Valve, 25 psi . . . . .	1
10.	KE54834-9	* Solenoid Valve, 2" . . . . .	1
	SE50400	Solenoid Valve Rebuilt Kit	
	SE50401	Solenoid Valve Replacement Coil	

**\* NOTE:** See SOLENOID VALVE MAINTENANCE section (pages 16-17) for further information.

11.	KE51654-3	Y-Strainer, 2" . . . . .	1
12.	KE50556-1	Water Level Probe Assembly, high and low level . . . . .	2
13.	KE52689	Heyco Bushing . . . . .	1
14.	SK50397	Plug Button . . . . .	1
15.	CT50097	Sensor, water bath temperature . . . . .	1
16.	FI05164	Thermocouple Connector, for sensor . . . . .	1
17.	KE54833-1	Snap-In Bushing . . . . .	1



KE51654-1	Y-Strainer, 1" . . . . .	3
FI00251	Plug, for 1" strainer . . . . .	3
KE51654-3	Strainer, 2" . . . . .	1
FI00252	Plug, for 2" strainer . . . . .	1

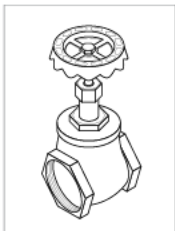

CT50249	Gate Valve, 1" . . . . .	2
CT50250	Gate Valve, 2" . . . . .	1

# SPRING ASSIST HINGE ASSEMBLY

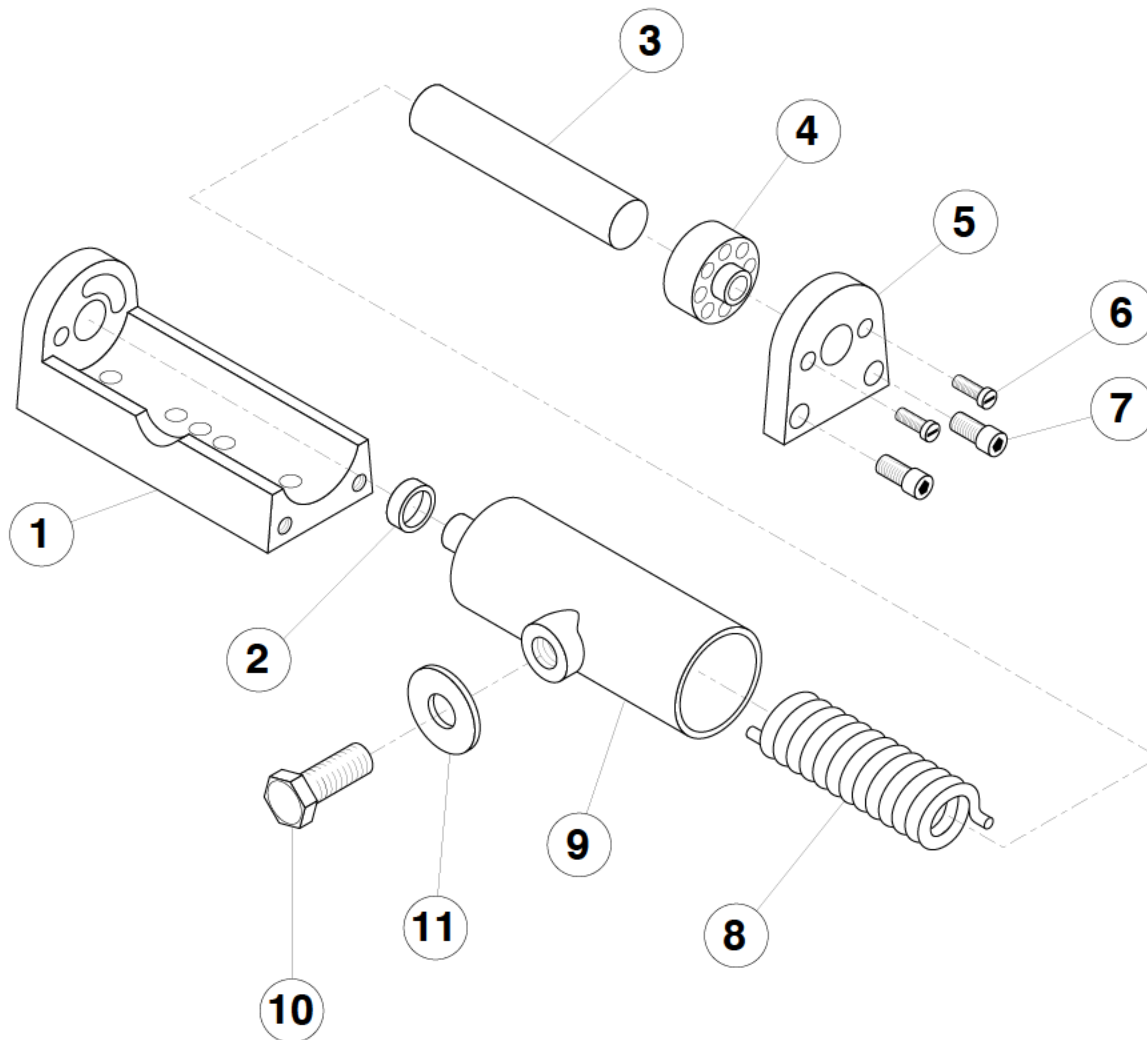

ITEM NO.	PART NO.	DESCRIPTION	QTY.
1.-9.	KE00677	Hinge Assembly .....	3
1.	KE51218	Body, spring assist hinge .....	1
2.	KE50824	Hinge Bearing .....	1
3.	KE50823	Pin, hinge .....	1
4.	KE50820	Insert, brass adjustment .....	1
5.	KE50819	End Piece .....	1
6.	FA11507	Screws, adjustment .....	2
7.	FA11284	Bolts, end block .....	2
8.	KE50122	Spring .....	1
9.	KE00653	Hinge .....	1
10.	FA11384	Bolt, 3/8" .....	1
11.	FA31031	Split Lockwasher .....	1

# MAINTENANCE

This unit requires very little preventive maintenance other than a daily cleaning. The chart recorder is a precision instrument and can be damaged by rough or careless handling. It will

also need to be recalibrated at regular intervals. Most Hospitals and Schools have a recalibration program for other equipment and this item has only to be added.

## HINGE ADJUSTMENT INSTRUCTIONS

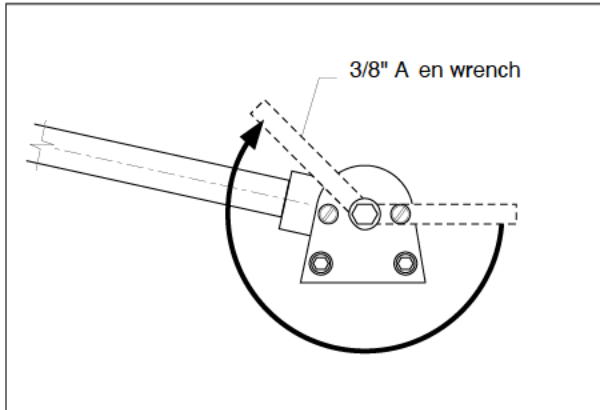

Hinge Adjustment

1. Insert 3/8" Allen wrench.
2. Turn clockwise to relieve tension on spring.
3. While tension is released remove one of the two slotted screws.
4. To prevent Allen wrench from springing back abruptly while the second slotted screw is removed, insert a pin (approximately 1/8") in the hole where the first slotted screw was removed from.
5. Remove second slotted screw.
6. While holding Allen wrench remove pin.
7. Turn Allen wrench clockwise to tighten or counter-clockwise to loosen tension to produce desired effect.
8. Re-insert pin in one of the two holes.
9. Tighten one slotted screw in the other hole (it may be necessary to turn Allen wrench slightly to align holes).
10. Remove pin and repeat step number 9 for other slotted screw.

## SWITCH CONFIGURATION & DISASSEMBLY

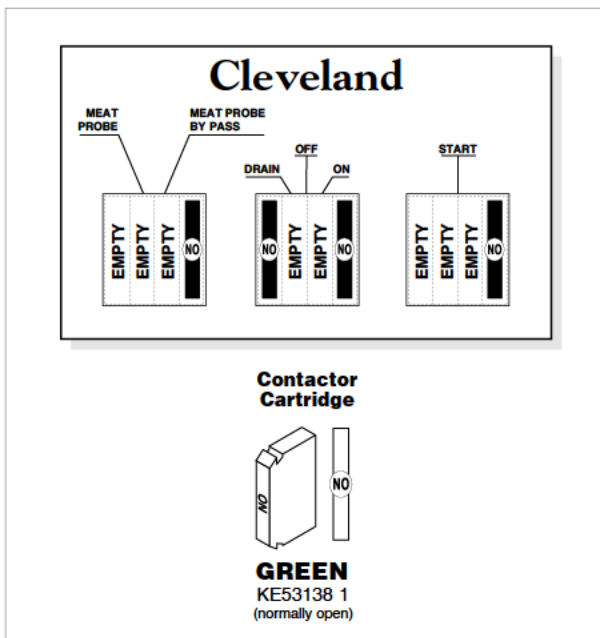

Contactor Locations Drawing

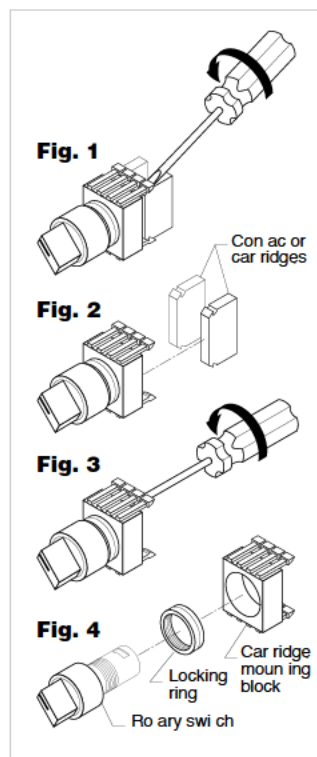

Switch Assembly Drawing

### DISASSEMBLY OF SWITCH ASSEMBLY

1. Place slotted screwdriver between contactor cartridge and cartridge mounting block as shown in **Fig.1**.
2. Twist screwdriver to free cartridge.
3. Place screwdriver under tab in the back of the cartridge mounting block as shown in **Fig. 3**.
4. Twist screwdriver to remove block from the rotary switch.
3. Unscrew locking ring to remove rotary switch.

# SOLENOID VALVE MAINTENANCE

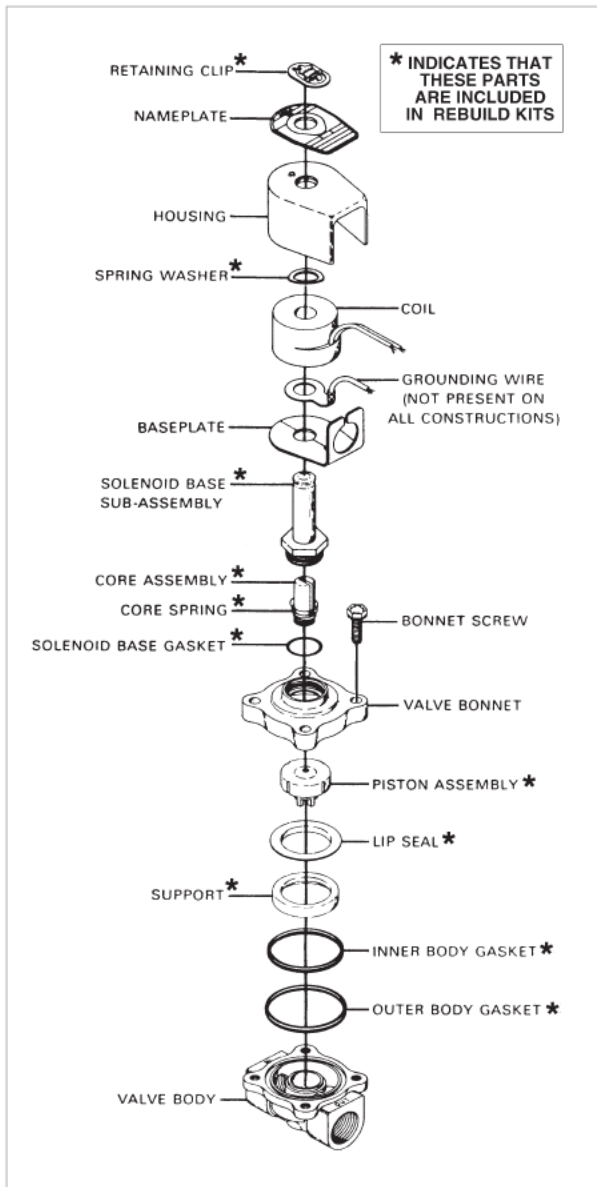

Solenoid Valve Exploded View Drawing

## Ordering Information

Parts marked with an asterisk (\*) in the Solenoid Valve Exploded View Drawing are supplied in the Rebuild Kits.

Valve # (Description)	Rebuild Kit#	Replacement Coil#
CT50182 (2", 120V/60 Hz.)	SE50400	SE50401
CT50244 (1", 120V/60 Hz.)	SE50402	SE50401
CT50245 (1", 120V/60 Hz.)	SE50403	SE50404
KE51652 (3/4", 120V/60 Hz.)	SE50405	SE50406
KE51656 (3/4", 120V/60 Hz., HW)	SE50407	SE50401
KE52668 (3/8", 120V/60 Hz.)	SE50408	SE50404
KE53007 (1 1/4", 120V/60 Hz.)	SE50409	SE50404
KE53159 (3/4", 120V/60 Hz.)	SE50410	SE50404

**NOTE:** It is not necessary to remove the valve from the pipeline for repairs.

**WARNING:** Turn off electrical power supply and depressurize valve before making repairs.

## Cleaning

All solenoid valves should be cleaned periodically. The time between cleanings will vary depending on the medium and service conditions. In general, if the voltage to the coil is correct, sluggish valve operation, excessive noise or leakage will indicate that cleaning is required. Clean valve strainer or filter when cleaning the valve.

## Preventive Maintenance

1. Keep the medium flowing through the valve as free from dirt and foreign material as possible.
2. While in service, the valve should be operated at least once a month to insure proper opening and closing.
3. Depending on the medium and service conditions, periodic inspection of internal valve parts for damage or excessive wear is recommended. Thoroughly clean all parts. Replace worn or damaged parts. However, for best results, replace all parts as supplied with a Rebuild Kit.

## Causes of Improper Operation

1. **Faulty Control Circuits:** Check the electrical system by energizing the solenoid. A metallic "click" signifies that the solenoid is operating. Absence of the "click" indicates loss of power supply. Check for loose or blown fuses, open circuited or grounded coil, broken lead wires or splice connections.
2. **Burned-Out Coil:** Check for open-circuited coil. Replace coil as necessary. Check supply voltage; it must be the same as specified on nameplate.
3. **Low Voltage:** Check voltage across the coil lead. Voltage must be at least 85% of nameplate rating.
4. **Incorrect Pressure:** Check valve pressure. Pressure to valve must be within range specified on nameplate.
5. **Excessive Leakage:** Disassemble valve and clean all parts. If leakage continues, replace all parts as supplied with a Rebuild Kit.

## **Coil Replacement**

**WARNING:** Turn off electrical power supply.

1. Disconnect coil lead wires and green grounding wire if present.
2. Remove retaining clip, nameplate and housing.

**WARNING:** When metal retaining clip disengages, it will spring upward.

3. Slip spring washer and coil off the solenoid base subassembly.
4. Coil is now accessible for replacement. Reassemble in reverse order of disassembly. Use Solenoid Valve Exploded View Drawing for identification and placement of parts.

**CAUTION:** Solenoid must be fully reassembled because the housing and internal parts complete the magnetic circuit.

## **Valve Disassembly**

**WARNING:** Depressurize valve and turn off electrical power supply.

1. Disassemble valve in an orderly fashion. Use exploded view for identification and placement of parts.
2. If necessary, disconnect coil lead wires, grounding wire (if present), and rigid conduit from solenoid housing,
3. Remove retaining clip and slip the entire solenoid enclosure off the solenoid base sub-assembly.

**WARNING:** When metal retaining clip disengages, it will spring upward,

4. Unscrew solenoid base sub-assembly and remove core assembly, core spring, and solenoid base gasket.
5. Remove bonnet screws, valve bonnet, piston assembly, lip seal, support, inner and outer body gaskets.
6. All parts are now accessible to clean or replace; Replace worn or damaged parts. However, for best results, replace all parts as supplied with an Rebuild Kit.

## **Valve Reassembly**

1. Reassemble in reverse order of disassembly. Use exploded view for identification and placement of parts.
2. Lubricate all gaskets with DOW CORNING 111® Compound lubricant or an equivalent high-grade silicone grease.
3. Position support and inner and outer body gaskets in valve body.
4. Position lip seal, flanged end up, onto piston assembly. Install piston assembly with lip seal into support in valve body cavity.
5. Replace valve bonnet and bonnet screws. Torque bonnet screws in a crisscross manner to 95 ±10 inch-pounds (10,7 ±1,1 newton-meters).
6. Replace solenoid base gasket, core assembly, and solenoid base sub-assembly. Torque solenoid base sub-assembly to 175 ±25 inch-pounds (19,8 ±2,8 newton-meters).
7. Replace solenoid enclosure and retaining clip.
8. Restore line pressure and electrical power supply to valve.
9. After maintenance is completed, operate the valve a few times to be sure of proper opening and closing.



# MOTOR REPLACEMENT PROCEDURE



**1** Swing screen to access impeller assembly.

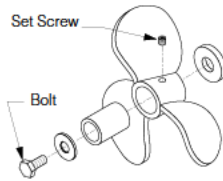

**2** Dissassemble impeller assembly by removing bolt and set screw.

**CAUTION:**  
Do not scratch.  
Extremely delicate surface.

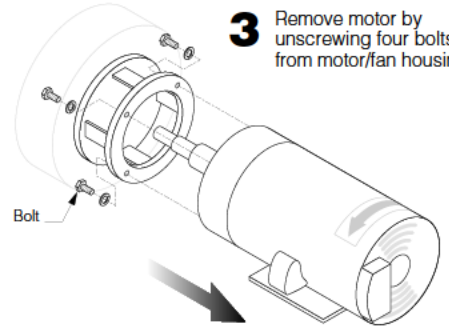

**3** Remove motor by unscrewing four bolts from motor/fan housing.

**4** Punch out taper pin and remove shaft extension from old motor.

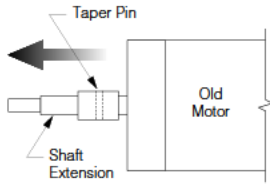

**5** Push shaft extension firmly onto new motor shaft.

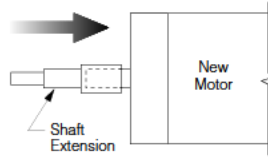

**6** Drill completely through shaft extension and new motor shaft using a 11/64" bit.

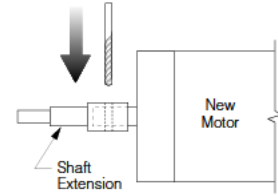

**NOTE:** Secure end of shaft with vice grips to prevent left or right rotation.

**7** Ream to a depth of 1" through shaft extension and new motor shaft using a #1 reamer.

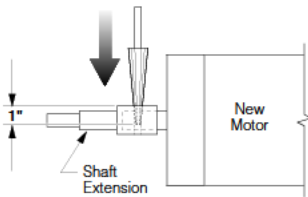

**8** Hammer taper pin (#2) into reamed hole.

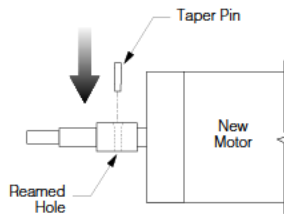

**9** Replace motor by screwing four bolts through motor/fan housing into motor (use lockwashers).

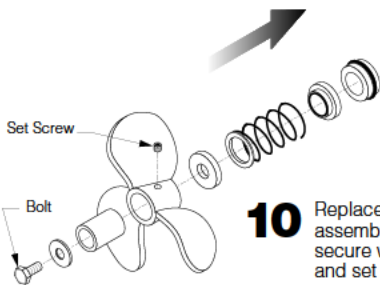
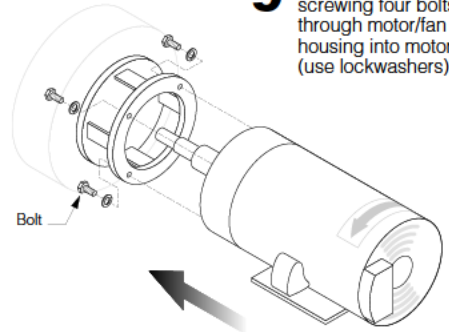

**10** Replace impeller assembly and secure with bolt and set screw.



**11** Swing screen to cover impeller assembly.

# PROGRAMMING INSTRUCTIONS

## MRC 7000 ENABLE MODE PROCEDURE (1&2 PEN)

Reference page #36 in the MRC 7000 Installation, Wiring, Operation Manual, Form 2877, Edition 6, May 1994 update.

To prevent tampering, your programmer comes from the factory with the programming modes turned "oFF".

If adjustment is required then the modes must be turned "ON" before they are accessible. We recommend that when the adjustments have been completed you turn off the programming modes again.

To turn on the mode required perform the following steps:

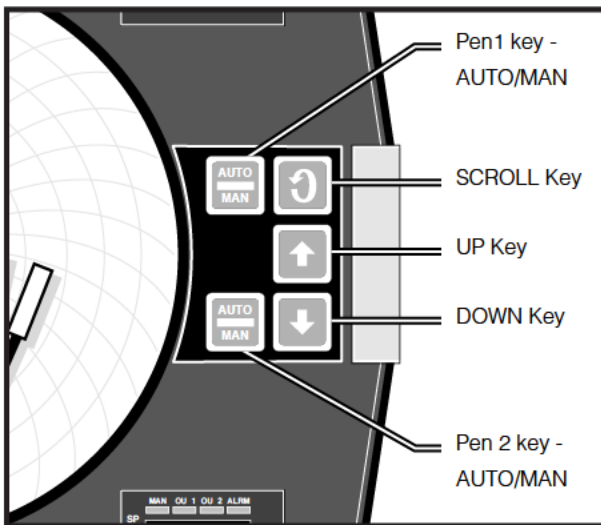

CAL 9900 Controls Drawing

1. Press the scroll key "↻" until "Ctrl" is displayed.
2. Press and hold the "↑" and "↓" keys at the same time. All the display lamps will light.
3. After 10 seconds the display lights will go out and "EnAb" will be displayed. Release the "↑" and "↓" keys. "EtSt" will appear.
4. Repeatedly press the "↓" key until the desired mode is displayed.
5. Press the scroll key "↻" once to display the mode's setting ("ON" or "oFF").
6. Press the "↑" key to turn the desired mode "ON".
7. To turn desired mode "oFF" follow steps 1-5 and then press "↓" key.

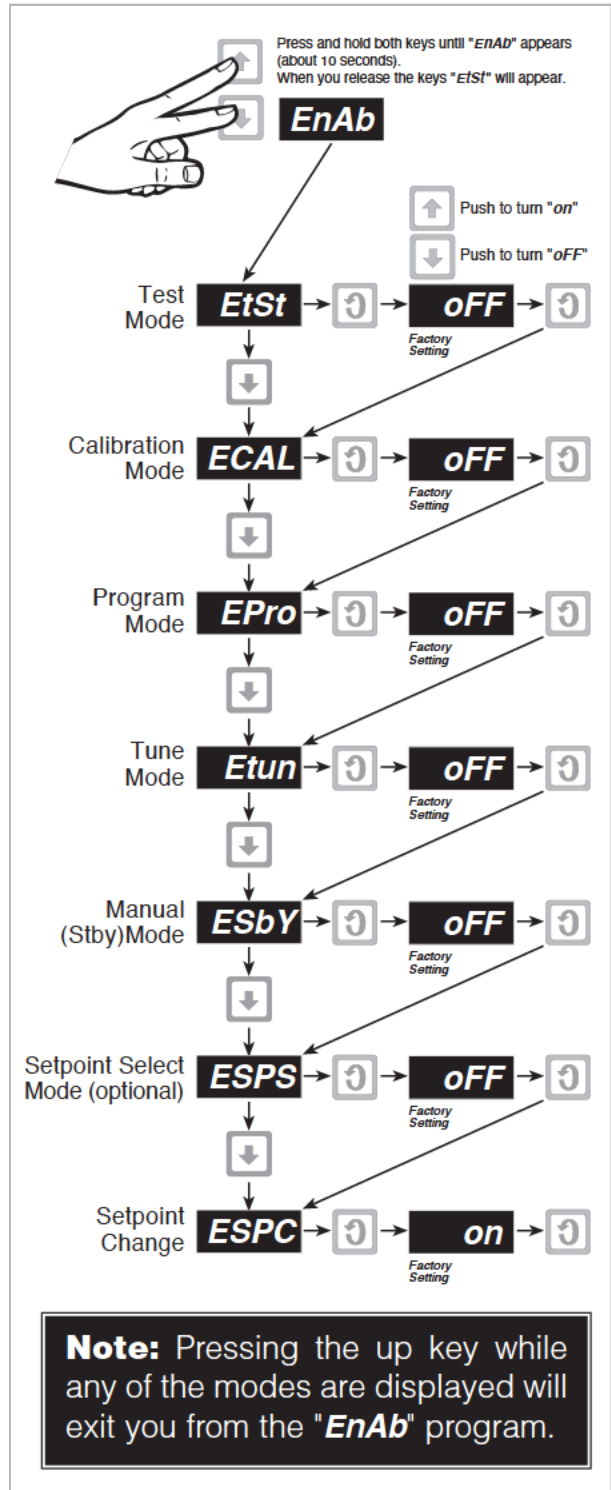

MRC 7000 Enable Mode Flow Chart

# MRC 7000 GENERAL PROGRAMMING INSTRUCTIONS (2 PEN)

The following instructions are of a general nature. Refer to the manual for complete instructions and explanations.

1. Install the chart recorder according to the wiring diagram.
2. Check and change the pin jumpers inside the chart recorder.
3. Set variables in controller by changing parameters in the Program mode (**Prog**) and the Tune mode (**tunE**).
4. Calibrate the pen using the Calibration mode (**CAL**). Use only (**CAL9**).

5. Use the Enable mode (**EnAb**) to turn off the Program mode (**EPro**), Calibration mode (**ECAL**), Tune mode (**Etun**), Manual (**Stby**) mode (**Esby**). The off setting means the mode is activated but cannot be accidentally changed.
6. See page 45 (MRC 7000 Installation, Wiring, Operation Manual) - Changing Charts and Changing Pens.

## Modes

Use the scroll key to move through the modes until the desired mode is reached. See Key Pad Controls pages 23-24 (MRC 7000 Manual). If the mode required does not show up on the digital display then the Enable mode will have to be accessed and the mode required turned on. See page 36 (MRC 7000 Manual- Enable Mode Configuration Procedure) or page 19 of this manual.

## Program Mode (Prog)

Following is a list of the factory settings. A brief description has been provided on items you may wish to change. See page 28-32 (MRC 7000 Manual) for further information.

DISPLAY CODE	FACTORY SETTING PEN 1	FACTORY SETTING PEN 2	DESCRIPTION
inPS	21	21	RTD °F
	20	20	RTD °C
iCor	0	0	Adjust to correct sensor error
out1	1	4	
o1uL	-	100	
o1LL	-	0	
out2	0	3	
o2uL	-	100	
o2LL	-	0	
AL1	0	0	
AL2	0	0	
diSP	2	2	display set to read process value and setpoint
dPoS	0	0	display set to zero decimal position
HyCo	1	5	Hysteresis band in degrees (glossary pg. 66 - MRC 7000 Manual) - adjust as required
HyAo	10	10	
SPuL	250	250	°F setpoint upper limit
	120	120	°C
SPLL	0	0	°F setpoint lower limit
	-10	-10	°C
AtFr	0	0	
Prnd	0	0	process value
dFF	1	1	
PFF	1	1	
Pout	0	0	
Cru	230	230	°F chart range upper level
	100	100	°C
CrL	30	30	°F chart range lower level
	0	0	°C
P1EC	-	0	
P2EC	-	0	
PAEC	1	1	on error condition, pen goes to 100% of chart
rLyA	5	-	relay A (meat probe) is assigned to output 1 - pen 1
rLyB	7	-	relay B (water bath) is assigned to output 2 - pen 2
CrT	24.0	-	chart rotation time in hours
COO	0	-	

## Tune Mode (tunE)

Following is a list of the factory settings. A brief description has been provided on items you may wish to change. See page 33-35 (MRC 7000 Manual) for further information.

DISPLAY CODE	FACTORY SETTING	DESCRIPTION
SoP	50	cooling comes on when temperature is exceeded by this amount
Pb1	10	proportional band for output 1, heating
Pb2	10	proportional band for output 2, cooling
rSEt	0	manual reset
ArSt	0	automatic reset
rAtE	0	rate
Ct1	30	cycle time for output 1, heating - <b>DO NOT DECREASE</b>
Ct2	30	cycle time for output 2, heating - <b>DO NOT DECREASE</b>
FoP	0	

## Calibration Mode (CAL)

The chart recorder is a sensitive instrument that requires periodic maintenance and recalibration.

Temperature, humidity, vibrations, and handling all contribute to causing errors in temperature reading. Regular inspections a recalibration by a trained service technician with the proper equipment will keep the unit accurate and reliable.

CAL 9 will calibrate the pen to the chart. This is the only calibration and you can do it without training and equipment. See page 46-49 (MRC 7000 Manual) for instructions.

## Enable Mode (EnAb)

The Enable mode allows you to lock out the other modes you do not wish to use or be tampered with. See page 36 (MRC 7000 Manual) or page 19 of this manual for operating instructions.

DISPLAY CODE	FACTORY SETTING	DESCRIPTION	AVAILABLE SETTINGS	FACTORY SETTING
EtSt	oFF	test mode	on or oFF	oFF
ECAL	oFF	calibration mode	on or oFF	oFF
EPro	oFF	program mode	on or oFF	oFF
Etun	oFF	tune mode	on or oFF	oFF
ESby	oFF	manual mode	on or oFF	oFF
ESPC	on	setpoint change	on or oFF	on

## Jumpers on Process Board

Open the front panel using a screw driver and check the jumpers on the processor board for correct positioning. See page 62 (MRC 7000 Manual) for board layout.

JUMPER	FUNCTION	POSITION
JU1	enable mode	unlocked
JU4	input, pen 1	T/C, mv, RTD
JU5	input, pen 2	T/C, mv, RTD
JU6	RTD input	T/C, mv, RTD
JU7	RTD input	RTD

# WIRING DIAGRAM

## Legend & Symbols

	ST - Start Contactor
	OL - Overload Relay
	S - Solenoid Valve
	LC1 - Water Level Control Board
	TD1 - Time Delay Relay (Impeller)
	TD2 - Time Delay Relay (Drain)
	SW1 - Switch (Drain/Off/On)
	SW2 - Switch (Meat Probe Bypass)
	LRb - Latch Relay (Bottom Coil)
	LRt - Latch Relay (Top Coil)
	CR - Relay Coil
	CR - Relay Contacts
	TB6 - Relays in Chart Recorder
	MRC7000 - Chart Recorder

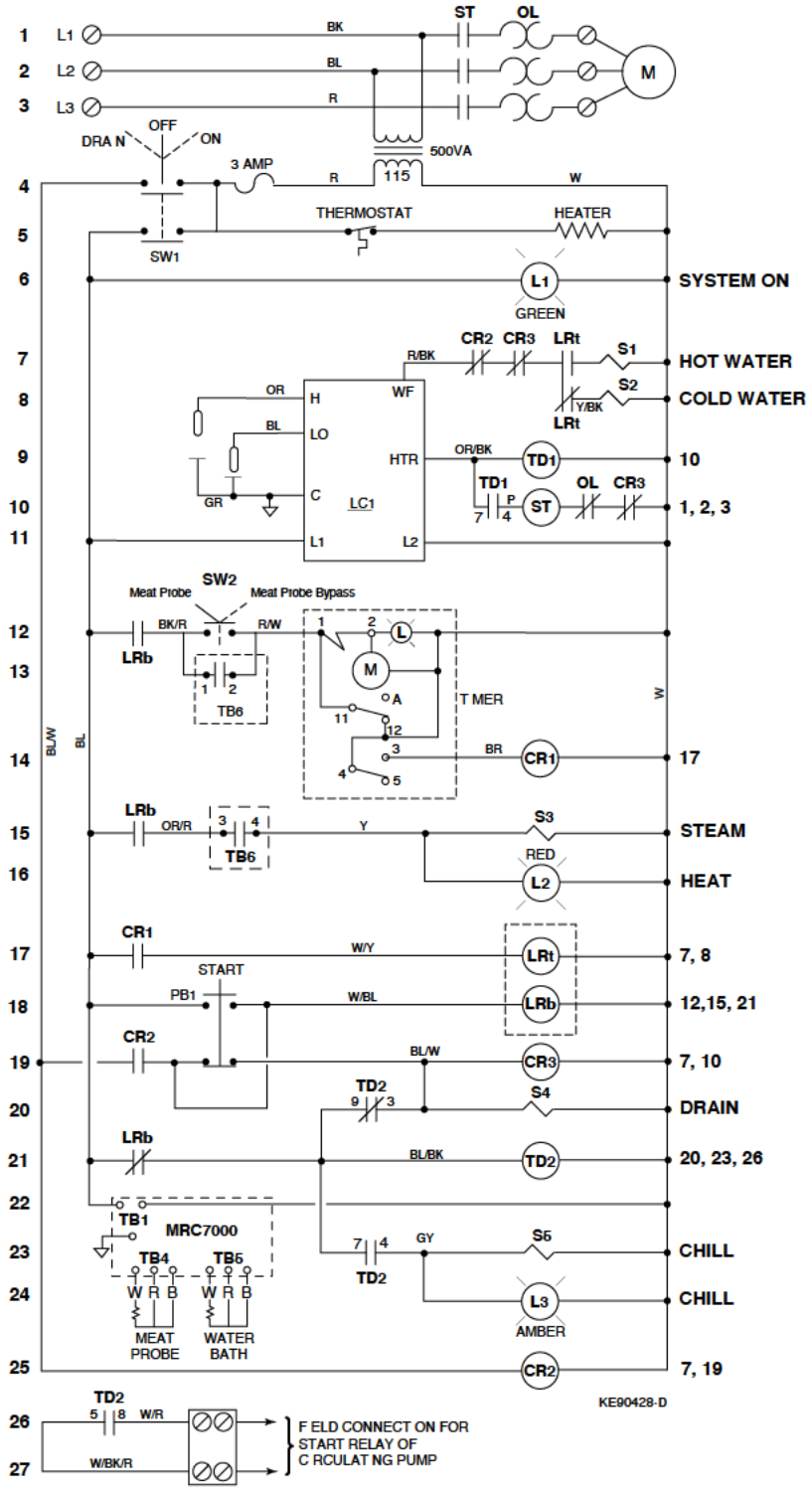
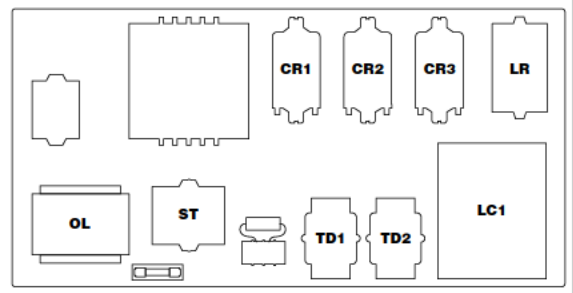

Notes:

