



Operators Manual

Installation, Operation & Service

GAS MIXING KETTLES HORIZONTAL AGITATOR

MODEL: HA-MKGL-60 HA-MKGL-60-T
 HA-MKGL-80 HA-MKGL-80-T
 HA-MKGL-100 HA-MKGL-100-T

 HA-MKGL-60-CC HA-MKGL-60-CC-T
 HA-MKGL-80-CC HA-MKGL-80-CC-T
 HA-MKGL-100-CC HA-MKGL-100-CC-T



Enodis

1333 East 179th St., Cleveland, Ohio, U.S.A. 44110

Phone: (216) 481-4900 Fax: (216) 481-3782
Visit our web site at www.clevelandrange.com

FOR THE USER

IMPORTANT!

ENSURE KETTLE IS AT ROOM TEMPERATURE AND PRESSURE GAUGE IS SHOWING ZERO OR LESS PRESSURE PRIOR TO REMOVING ANY FITTINGS.

FOR YOUR SAFETY

DO NOT STORE OR USE GASOLINE OR ANY OTHER FLAMMABLE LIQUIDS AND VAPOURS IN THE VICINITY OF THIS OR ANY OTHER APPLIANCE.

WARNING: Improper installation, adjustment, alteration, service or maintenance can cause property damage, injury or death. Read the installation and operating instructions thoroughly before installing or servicing this equipment.

IMPORTANT

The following points are to insure the safe installation and operation of this equipment:

- Insure all gas and electrical supplies match rating plate and electrical stickers.
- Observe all clearance requirements.
- Disconnect the electrical power supply to the appliance before cleaning or servicing unit.
- All service must be performed by a qualified Cleveland Range Technician.
- Do not obstruct the flow of combustion and ventilation air.

The installation and connection must comply with current local codes, or in the absence of local codes, with CAN/CGA-B149.1 and .2 installation code or with the national fuel gas code, ANSI Z223.1-L988.

Post in a prominent location, instructions to be followed in the event the user smells gas. This information shall be obtained by consulting your local gas supplier.

The appliance and its individual shut off valve must be disconnected from the gas supply piping system during any pressure testing of that system at test pressures in excess of 1/2 psig. (3.45 kpa).

The appliance must be isolated from the gas supply piping system by closing its individual manual shut off valve during any pressure testing of the gas supply piping system at test pressures equal to or less than 1/2 psig. (3.45 kpa).

RETAIN THIS MANUAL FOR YOUR REFERENCE.

For your safety

DANGER

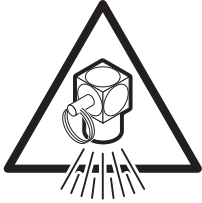

Keep clear of pressure relief discharge.



Keep hands away from moving parts and pinch points.

IMPORTANT



Inspect unit daily for proper operation.

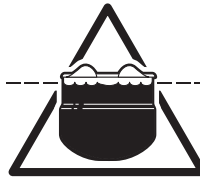

Do not fill kettle above recommended level marked on outside of kettle.

CAUTION



Surfaces may be extremely hot! Use protective equipment.



Wear protective equipment when discharging hot product.



Do not lean on or place objects on kettle lip.



Stand clear of product discharge path when discharging hot product.

SERVICING

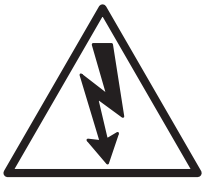

Shut off power at main fuse disconnect prior to servicing.



Ensure kettle is at room temperature and pressure gauge is showing zero or less prior to removing any fittings.

GAS APPLIANCES

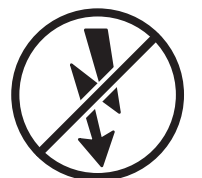

Do not attempt to operate this appliance during a power failure.



Keep appliance and area free and clear of combustibles.

INSTALLATION

GENERAL

Installation of the kettle must be accomplished by qualified installation personnel working to all applicable local and national codes. Improper installation of product could cause injury or damage.

This equipment is built to comply with applicable standards for manufacturers. Included among those approval agencies are: UL, A.G.A., NSF, ASME/N.Bd., CSA, CGA, ETL, and others. Many local codes exist, and it is the responsibility of the owner/installer to comply with these codes.

Observe all clearance requirements to provide proper make-up air flow as well as sufficient clearance for servicing.

Dimensions and clearance specifications are shown on the specification sheet and in the Clearance Requirements section. Do not install kick plates or otherwise obstruct the flow of combustion and ventilation air.

Check rating plate to ensure that kettle has been equipped to operate with the type of gas available at the installation.

VENTILATION

Gas fired kettles are only to be installed under a ventilation hood in a room which has provisions for adequate make up air. Further information can be obtained by referring to the U.S.A. National Fire Protection Associations NFPA96 regulations. These standards have also been adopted by the National Building Code in Canada.

INSPECTION

Before unpacking visually inspect the unit for evidence of damage during shipping. If damage is noticed, do not unpack the unit, follow shipping damage instructions.

SHIPPING DAMAGE INSTRUCTIONS

If shipping damage to the unit is discovered or suspected, observe the following guidelines in preparing a shipping damage claim.

1. Write down a description of the damage or the reason for suspecting damage as soon as it is discovered. This will help in filling out the claim forms later.
2. As soon as damage is discovered or suspected, notify the carrier that delivered the shipment.
3. Arrange for the carrier's representative to examine the damage.
4. Fill out all carrier claims forms and have the examining carrier sign and date each form.

CLEARANCE REQUIREMENTS

This unit must be installed in accordance with the clearances shown on the rating label which is adhered to the unit.

FOR YOUR SAFETY. Keep the appliance area free and clear of combustible materials.

KETTLE

1. When removing the kettle from the platform, handle with care to prevent scratching or any other damage. It is imperative that the kettle be level before bolting to the floor. This will prevent any twist or out of roundness to the kettle and will stop deflection of the agitator. Make sure the kettle is securely bolted to the floor and follow the procedure listed below:
 - ⇒ Raise the flange on the leg under the motor so that it sets freely (stationary kettles only).
 - ⇒ Position the kettle in its permanent location, check clearances and level the kettle by turning the adjustable feet.
 - ⇒ Lower the flange or flanges under the motor channel. Over adjustment, whether up or down, could cause misalignment and cause damage to the agitator drive shaft and hub (stationary kettles only).
2. Next you must check the alignment of the drive shaft for a uniform clearance between the hub and the shaft. In order to check for clearance you must remove the seal cover plate and pull the seal back. You can check the distance for clearance by using a wire feeler gauge.
3. If adjustment is required for side direction, loosen the motor bolts, center the shaft and retighten. If vertical alignment is needed, loosen the motor bolts and add a shim to raise or remove a shim to lower. Retighten bolts. When this is complete, check to see if the agitator shaft coupling slides freely for easy removal of the agitator.
4. Once positioned and leveled, permanently secure the kettle's flanged feet to the floor using 1/2 x 2 1/2 inch lag bolts and floor anchors (supplied by the installer). Two bolts per leg are required to secure each of the flanged feet.

CONTROL PANEL

Refer to Wiring Diagram supplied with Control Panel for installation instructions.

GAS

It is recommended that a sediment trap (drip leg) be installed in the gas supply line. If the gas pressure exceeds 14" water column, a pressure regulator must be installed, to provide a maximum of 14" water column gas pressure to the gas control valve.

Connect the gas supply piping to the input side of the gas control valve. Location and pressure data are shown on the specification sheet.

Installation must be in accordance with local codes and/or the National Fuel Gas Code ANSI Z223.1-1988 (USA) or the Installation Codes for Gas Burning Appliances and Equipment CANI B149.1 and B149.2 (Canada). Use a gas pipe joint compound which is resistant to L.P. gas. Test all pipe joints for leaks with soap and water solution. Ensure that the gas pressure regulator is set for the manifold pressure indicated on the gas rating plate.

The appliance and its individual shut-off valve must be disconnected from the gas supply piping system during any pressure testing of that system at test pressures in excess of 1/2 psi (3.45 kPa). The appliance must be isolated from the gas supply piping system by closing its individual manual shut-off valve during any pressure testing of the gas supply piping system at test pressures equal to or less than 1/2 psi (3.45 kPa).

ELECTRICAL

Electrical installation must be in accordance with local codes and/or the National Electric Code ANSI/NFPA 70-1990 (USA) or the Canadian Electrical Code CSA Standard C22.1 (Canada). The kettle must be electrically grounded by the installer.

A separate fused disconnect switch must be supplied and installed in the high voltage electrical supply line.

The wire gauge size and electric supply must match the power requirements specified on the kettle's rating plate. The waterproof conduit enclosed permanent copper wiring must be adequate to carry the required current at the rated voltage. Refer to the SPECIFICATION SHEET or RATING LABEL for electrical specifications and location of electrical connections.

Remove the screws securing the component cover (located to the left rear side of kettle), and remove the cover. A wiring diagram is affixed to the inside of the cover. Feed conduit enclosed permanent copper wiring through the cut-out in the bottom of the console and fasten to the terminal block. Fasten the ground wire to the ground lugs connected to the frame, beside the terminal block. Replace the console cover and secure it with the screws.

WATER

The sealed jacket of the gas-fired kettle is precharged with the correct amount of a water-based formula, and therefore, no water connection is required to the kettle jacket.

CLEANING

After installation the kettle must be thoroughly cleaned and sanitized prior to cooking.

WARRANTY

Our Company supports a worldwide network of Maintenance and Repair Centres. Contact your nearest Maintenance and Repair Centre for replacement parts, service, or information regarding the proper maintenance and repair of your cooking equipment

In order to preserve the various agency safety certification (UL, A.G.A., NSF, ASME/Ntl. Bd., etc.), only factory-supplied replacement parts should be used. The use of other than factory supplied replacement parts will void warranty.

OPERATING INSTRUCTIONS

Parts Description - Kettle



NOTE:
Location of switches may vary dependant on customers specific options

- A**
- Red Low Water Indicator Light**
When lit, in the upright position, indicates kettle gas burner has cut out and unit requires more water. Occasional pulsing of this light is normal.
 - Green Heat Indicator Light**
When lit, indicates gas burner is on; cycles on-off with solid state controls.
 - Solid State Temperature Control Knob / On-Off Toggle Switch**
Controls electrical power to kettle, and allows operator to select kettle heat increments from minimum, 1-10. A setting of 7 or higher will boil water
 - Amber Ignition Failure Indicator Light**
Indicates failure of heating system to ignite (Used prior to July 2004)

- B**
- Agitator Stop Button**
Stops agitator in case of emergency
 - Agitator Start Switch**
Starts agitator. Agitator power control switch must be ON
 - Agitator Power Switch**
Allows power to agitator. When not in use, turn control power OFF
 - Agitator Speed Control Switch**
Turn clockwise until desired speed is reached
- C**
- Power tilt control switch**
Tilts kettle for pouring; some kettles have manual hand tilt
 - Reset circuit breaker**
Protects power tilt system from overload. Push to reset



Water Meter Digital Counter (not shown)
Location may vary dependant on customer's specific options

- D**
- Fill Interrupt Switch**
Interrupts water fill cycle
 - Potable Fill Water Switch**
Selects hot or cold water
 - Fill Cycle Switch**
Start/continue cycle switch
- E**
- Product Discharge Valve Switch**
Toggle momentary switch to desired valve opening

- 1** **Temperature Sensor**
Senses temperature of product
- 2** **Automatic Dump Valve**
Empties kettle of either food product or wash water
- 3** **Sight Glass**
For checking water level of kettle jacket
- 4** **Vacuum /Pressure Gauge**
Indicates steam pressure inside steam jacket in PSI, as well as vacuum in inches of mercury
- 5** **Gas Shut-Off Valve**
- 6** **Air Quick Connect**
Push yellow tab down to release air pressure before disconnecting air hose
- 7** **Kettle Filler Nozzle**

General

WARNING: Do not attempt to operate this appliance during a power failure. Keep appliance and area free and clear of combustibles.

Before turning kettle on, ensure that following conditions exist:

- If you are cooking an egg or milk product, do not pre-heat kettle.
- The vacuum/pressure gauge needle is in green zone; if it is not and is in "vent air" zone, call your service agent to repair leak.
- The electrical service to kettle is turned on

NOTE: The kettle should be sanitized prior to the daily production run - see CLEANING INSTRUCTIONS .

Mixing ("AGITATOR ")

WARNING:

- Never add product to kettle while agitator is running.
- Do not put hands in kettle.
- Watch for loose clothing near agitator.

1. Turn "**SPEED CONTROL**" to "**0**".
2. Switch agitator to "**ON**".
3. Push agitator "**START**" to initiate mixing.
4. Turn "**SPEED CONTROL**" to desired mixing speed.
5. To stop mixing action, push agitator stop button.

NOTE: Mixing speed depends on the product consistency. The faster the mixing speed the more damage may be done to fragile product.







Heating (General Notes)

- The green light cycles on and off, indicating that burners are cycling to maintain set temperature.
- The red "low water" light should not be lit during operation. This light indicates that water level is critically low and that gas burners have automatically shut off. Before further use, refer to RESERVOIR FILL INSTRUCTIONS for adding distilled water.
- Occasional flashing of the red "low water" light is ok while kettle is heating.

Manual Heating

1. Switch "POWER" to "ON".
2. Turn temperature control knob to desired setting.
3. Switch "**CONTROLLER**" to "**BYPASS**".
4. After closing discharge valve, place product in kettle.

Automatic Heating

1. Switch "**CONTROLLER**" to "**ACTIVE**".
2. Turn temperature control knob to "**10**".
3. Continually push function key "  " until "**OFF**" is displayed.
4. Push and hold key "  " or "  " until desired temperature is set.
5. To Start: push function key "  " until "**Ctrl**" is displayed.
6. Push down key "  " .
7. To Stop: push function key "  " until "**OFF**" is displayed.
8. Push down key "  " .
9. After closing discharge valve, place product in kettle.



Emptying the Kettle

1. To open automatic dump valve:
 - Turn PRODUCT DISCHARGE VALVE switch clockwise to JOG TO OPEN. Release switch to the HOLD position when desired valve opening is achieved.
 - To close valve, turn switch counterclockwise to CLOSED position.
2. To avoid splashing, slowly empty kettle contents into an appropriate container by partially opening dump valve.

NOTE: When pumping with a Metering Filling Station the speed of the agitator arm must be sufficient to suspend the heavier items in the mix in order to achieve an even distribution in your packaged items.

3. Immediately clean kettle as outlined in CLEANING INSTRUCTIONS on page.

Water Meter

1. Switch "**POTABLE FILL WATER**" to "**HOT**" or "**COLD**".
2. Set required volume by first pushing the "  " key until the digit you want to change is flashing in the lower display. Then use the "  " key to change the value of the selected digit.

When all digits are set, press the "**ENT**" key.

3. Locate delivery spout over kettle.
4. Turn switch to "**RESET**". Delivery will start at "**0**" and stop at preset volume.
5. To stop delivery at any time, turn "**FILL INTERRUPT**" switch to "  " .
6. To complete delivery after interrupting, turn switch "**FILL CYCLE**" to "**CONTINUE**".





CLEANING INSTRUCTIONS



CARE AND CLEANING

Cooking equipment must be cleaned regularly to maintain its fast, efficient cooking performance and to ensure its continued safe, reliable operation. The best time to clean is shortly after each use (allow unit to cool to a safe temperature).

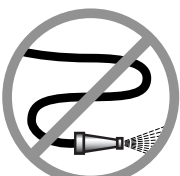
WARNINGS

- ⇒  Do not use detergents or cleansers that are chloride based or contain quaternary salt.
Chloride Cleaners
- ⇒  Do not use a metal bristle brush or scraper.
Wire Brush &
- ⇒  Steel wool should never be used for cleaning the stainless steel.
Steel Pads
- ⇒  Unit should never be cleaned with a high pressure spray hose.
High Pressure Spray Hose
- ⇒  Do not leave water sitting in unit when not in use.
Stagnant Water

CLEANING INSTRUCTIONS

1. Turn unit off.
2. Remove drain screen (if applicable). Thoroughly wash and rinse the screen either in a sink or a dishwasher.
3. Prepare a warm water and mild detergent solution in the unit.
4. Remove food soil using a nylon brush.
5. Loosen food which is stuck by allowing it to soak at a low temperature setting.
6. Drain unit.
7. Rinse interior thoroughly.
8. If the unit is equipped with a **Tangent Draw-Off Valve**, clean as follows:
 - a) Disassemble the draw-off valve first by turning the valve knob counter-clockwise, then turning the large hex nut counter-clockwise until the valve stem is free of the valve body.
 - b) In a sink, wash and rinse the inside of the valve body using a nylon brush.
 - c) Use a nylon brush to clean tangent draw-off tube.
 - d) Rinse with fresh water.
 - e) Reassemble the draw-off valve by reversing the procedure for disassembly. The valve's hex nut should be hand tight only.
9. If the unit is equipped with a **Butterfly Valve**, clean as follows:
 - a) Place valve in open position.
 - b) Wash using a warm water and mild detergent solution.
 - c) Remove food deposits using a nylon brush.
 - d) Rinse with fresh water.
 - e) Leave valve open when unit is not in use.
10. Using mild soapy water and a damp sponge, wash the exterior, rinse, and dry.

NOTES

- ⇒ For more difficult cleaning applications one of the following can be used: alcohol, baking soda, vinegar, or a solution of ammonia in water.
- ⇒ Leave the cover off when the kettle is not in use.
- ⇒ For more detailed instructions refer to the Nafem Stainless Steel Equipment Care and Cleaning manual (supplied with unit).

FLUSH PISTON VALVE

(Used prior to 2003.)

Daily - clean valve as follows:

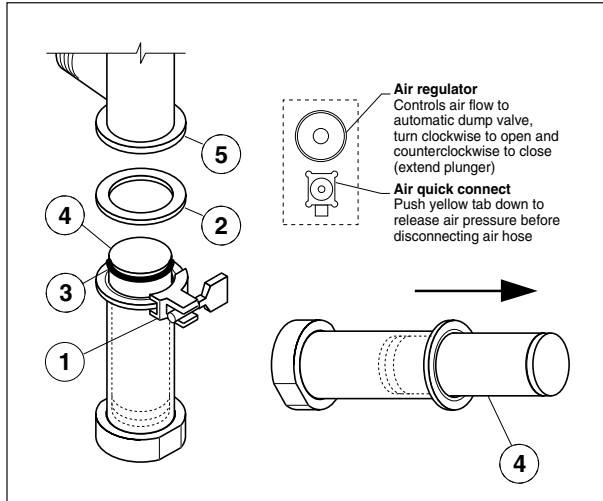

To remove valve from kettle:

1. Place valve in open position.
2. Holding bottom of valve, loosen and remove sani-clamp (1).
3. Lower valve, and remove from body.
4. Remove sani-clamp seal (2) and "O" ring (3).
5. With valve on its side, turn air dial counterclockwise to extend plunger.
6. Disconnect air supply at valve.
7. Being careful not to submerge entire valve in water, wash cylinder body (4), inside valve body (5), "O" ring and seal.
 - ⇒ Wash in a sink, using a warm water and mild detergent solution.
 - ⇒ Rinse with fresh water and then sanitize using a properly diluted sanitizing solution.
 - ⇒ Allow to air dry thoroughly on a flat, clean surface.

To install valve on kettle:

1. Replace "O" ring and seal if worn.
2. Coat cylinder body and "O" ring with cooking oil or food safe grease.
3. Coat kettle cylinder with cooking oil.
4. Reconnect air supply.
5. With valve on its side, place valve in open position by turning air regulator clockwise.
6. Put valve in place, and secure with sani-clamp.

(Used after 2003.)

Daily - clean valve as follows:

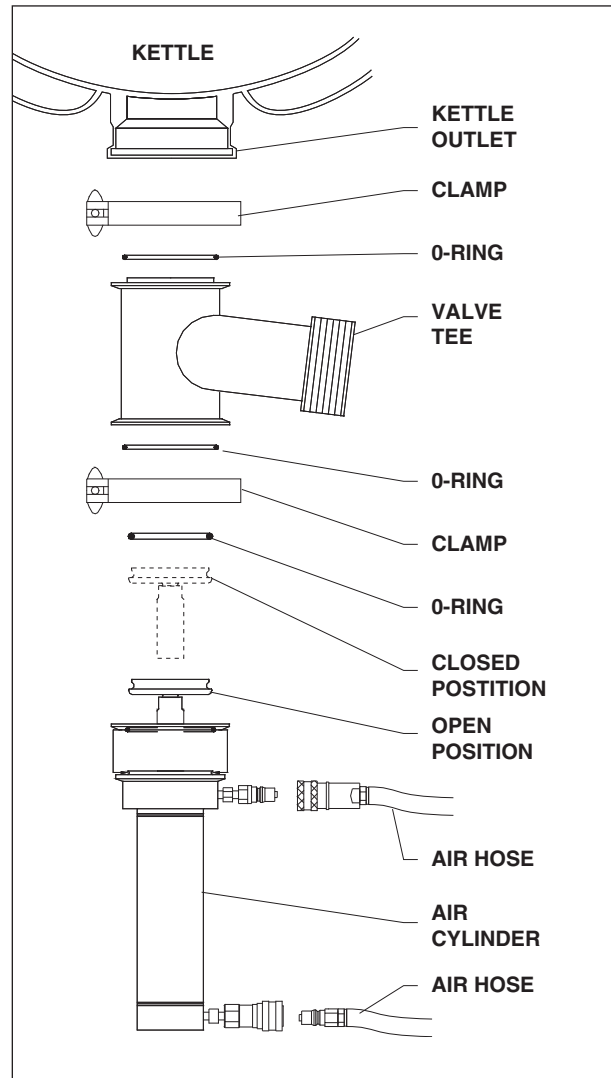

1. Open product valve.
2. Disconnect air hoses.
3. Remove air cylinder.
4. Remove valve tee.
5. Remove all O-rings.
6. Clean air cylinder, do not submerge in water. Wipe clean and sanitize.
7. Clean and sanitize tee and O-rings.
8. Grease and reinstall O-rings.
9. Reinstall tee to kettle outlet.
10. Reinstall air cylinder to bottom of tee.
11. Reconnect air hoses.
12. Close valve and check for alignment.

AGITATOR

To remove and clean agitator (two-person job):

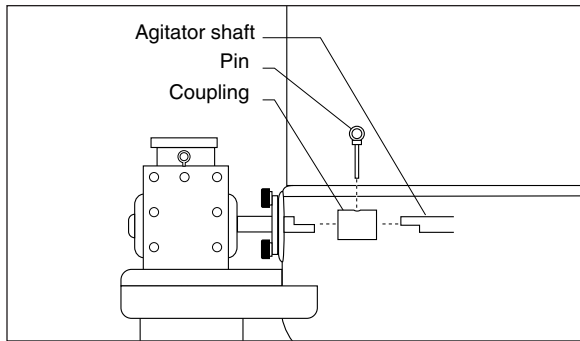

1. Remove scraper blades.
2. Rotate agitator until pull pin is on top side.
3. Turn power OFF.
4. Pull pin out.
5. Slide coupling toward kettle wall, and carefully lift agitator pulling back to lift out.
6. Clean in a sink, using a warm water and mild detergent solution.
7. Rinse with fresh water.

AGITATOR BUSHING

With agitator out, remove bushing by:

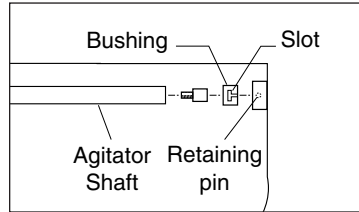

1. Remove bushing by turning 1/4 turn and pulling away from the kettle wall.
2. Clean, rinse and sanitize bushing and bushing mounting area.
3. Lubricate metal surfaces with food safe grease.
4. Install bushing by locating retaining pin and sliding bushing on.
5. Rotate to lock into position.

SCRAPER BLADES

To remove and clean scraper blades:

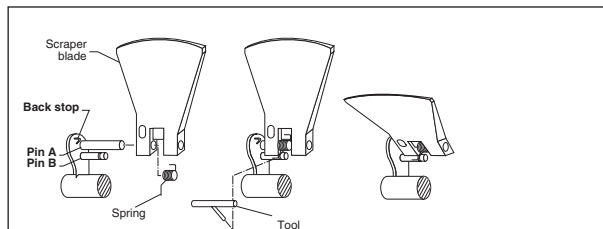

Fig. 1

Fig. 2

Fig. 3

To Remove Scraper Blade

1. Insert tool that is provided as shown in Fig. 2.
2. Pull up on spring arm until arm clears groove in Pin B.
3. Spring is now disengaged, gently release spring to remove scraper blade.

To Install Scraper Blade

1. Slide scraper blade and spring onto Pin A as shown in Fig. 1.
2. Hook spring arm and pull up.
3. Using tool, engage spring arm into groove on Pin B. Scraper blade is now in place.

1. Remove scraper blades using the tool to release the spring from the retaining pin and sliding the blade off the shaft.
2. Place parts in a pan of warm water to soak.
3. Clean in a sink, using a warm water and mild detergent solution.
4. Rinse with fresh water.
5. Allow to dry thoroughly on a flat, clean surface.

QUAD RING

(Used prior to June 1999)

To clean agitator quad ring:

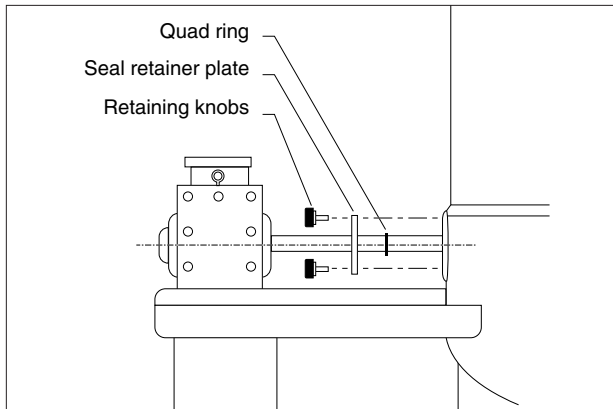

1. Remove retaining knobs.
2. Slide shaft seal retainer plate and quad ring away from kettle body.
3. Clean quad ring, shaft, and seal retainer plate with clean cloth.
4. Rinse with fresh water.
5. Apply light coat of food safe grease to both sides of the quad ring.
6. Slide quad ring back into original position, making sure it does not twist.
7. Slide retainer plate back toward kettle, replacing retaining knobs.
8. Tighten with hand pressure only.

SEAL RETAINER PLATE

(Replaces QUAD RING after June 1999.)

To clean seal retainer plate:

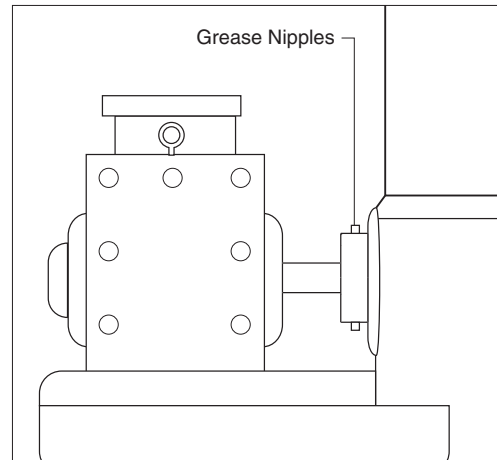

1. Apply food safe grease to grease nipples until you see clean grease inside the kettle. Grease daily.

STAINLESS STEEL EQUIPMENT CARE AND CLEANING

(supplied courtesy of Nafem. For more information visit their web site at www.nafem.org)

Contrary to popular belief, stainless steels ARE susceptible to rusting.

Corrosion on metals is everywhere. It is recognized quickly on iron and steel as unsightly yellow/orange rust. Such metals are called "active" because they actively corrode in a natural environment when their atoms combine with oxygen to form rust.

Stainless steels are passive metals because they contain other metals, like chromium, nickel and manganese that stabilize the atoms. 400 series stainless steels are called ferritic, contain chromium, and are magnetic; 300 series stainless steels are called austenitic, contain chromium and nickel; and 200 series stainless, also austenitic, contains manganese, nitrogen and carbon. Austenitic types of stainless are not magnetic, and generally provide greater resistance to corrosion than ferritic types.

With 12-30 percent chromium, an invisible passive film covers the steel's surface acting as a shield against corrosion. As long as the film is intact and not broken or contaminated, the metal is passive and stain-less. If the passive film of stainless steel has been broken, equipment starts to corrode. At its end, it rusts.

Enemies of Stainless Steel

There are three basic things which can break down stainless steel's passivity layer and allow corrosion to occur.

1. Mechanical abrasion
2. Deposits and water
3. Chlorides

Mechanical abrasion means those things that will scratch a steel surface. Steel pads, wire brushes and scrapers are prime examples.

Water comes out of the faucet in varying degrees of hardness. Depending on what part of the country you live in, you may have hard or soft water. Hard water may leave spots, and when heated leave deposits behind that if left to sit, will break down the passive layer and rust stainless steel. Other deposits from food preparation and service must be properly removed.

Chlorides are found nearly everywhere. They are in water, food and table salt. One of the worst chloride perpetrators can come from household and industrial cleaners.

So what does all this mean? Don't Despair!

Here are a few steps that can help prevent stainless steel rust.

1. Use the proper tools.

When cleaning stainless steel products, use non-abrasive tools. Soft cloths and plastic scouring pads will not harm steel's passive layer. Stainless steel pads also can be used but the scrubbing motion must be in the direction of the manufacturers' polishing marks.

2. Clean with the polish lines.

Some stainless steel comes with visible polishing lines or "grain." When visible lines are present, always scrub in a motion parallel to the lines. When the grain cannot be seen, play it safe and use a soft cloth or plastic scouring pad.

3. Use alkaline, alkaline chlorinated or non-chloride containing cleaners.

While many traditional cleaners are loaded with chlorides, the industry is providing an ever-increasing choice of non-chloride cleaners. If you are not sure of chloride content in the cleaner used, contact your cleaner supplier. If your present cleaner contains chlorides, ask your supplier if they have an alternative. Avoid cleaners containing quaternary salts; it also can attack stainless steel and cause pitting and rusting.

4. Treat your water.

Though this is not always practical, softening hard water can do much

to reduce deposits. There are certain filters that can be installed to remove distasteful and corrosive elements. To insure proper water treatment, call a treatment specialist.

5. Keep your food equipment clean.

Use alkaline, alkaline chlorinated or non-chloride cleaners at recommended strength. Clean frequently to avoid build-up of hard, stubborn stains. If you boil water in stainless steel equipment, remember the single most likely cause of damage is chlorides in the water. Heating cleaners that contain chlorides have a similar effect.

6. Rinse, rinse, rinse.

If chlorinated cleaners are used, rinse and wipe equipment and supplies dry immediately. The sooner you wipe off standing water, especially when it contains cleaning agents, the better. After wiping equipment down, allow it to air dry; oxygen helps maintain the stainless steel's passivity film.

7. Never use hydrochloric acid (muriatic acid) on stainless steel.

8. Regularly restore/passivate stainless steel.

Recommended cleaners for specific situations

Job	Cleaning Agent	Comments
Routine cleaning	Soap, ammonia, detergent, Medallion	Apply with cloth or sponge
Fingerprints & smears	Arcal 20, Lac-O-Nu Ecoshine	Provides barrier film
Stubborn stains & discoloration	Cameo, Talc, Zud, First Impression	Rub in direction of polish lines
Grease & fatty acids, blood, burnt-on-foods	Easy-off, De-Grease It Oven Aid	Excellent removal on all finishes
Grease & oil	Any good commercial detergent	Apply with sponge or cloth
Restoration/Passivation	Benefit, Super Sheen	

Review

1. Stainless steels rust when passivity (film-shield) breaks down as a result of scrapes, scratches, deposits and chlorides.
2. Stainless steel rust starts with pits and cracks.
3. Use the proper tools. Do not use steel pads, wire brushes or scrapers to clean stainless steel.
4. Use non-chlorinated cleaners at recommended concentrations. Use only chloride-free cleaners.
5. Soften your water. Use filters and softeners whenever possible.
6. Wipe off cleaning agent(s) and standing water as soon as possible. Prolonged contact causes eventual problems.

To learn more about chloride-stress corrosion and how to prevent it, contact the equipment manufacturer or cleaning materials supplier.

Developed by Packer Engineering, Naperville, Ill., an independent testing laboratory.

SERVICE PARTS

WARRANTY

Our Company supports a worldwide network of Maintenance and Repair Centers. Contact your nearest Maintenance and Repair Centre for replacement parts, service, or information regarding the proper maintenance and repair of your cooking equipment.

In order to preserve the various agency safety certification (UL, NSF, ASME/NTI, Bd., etc.), only factory-supplied replacement parts should be used. The use of other than factory supplied replacement parts will void warranty.

FAUCET ASSEMBLY

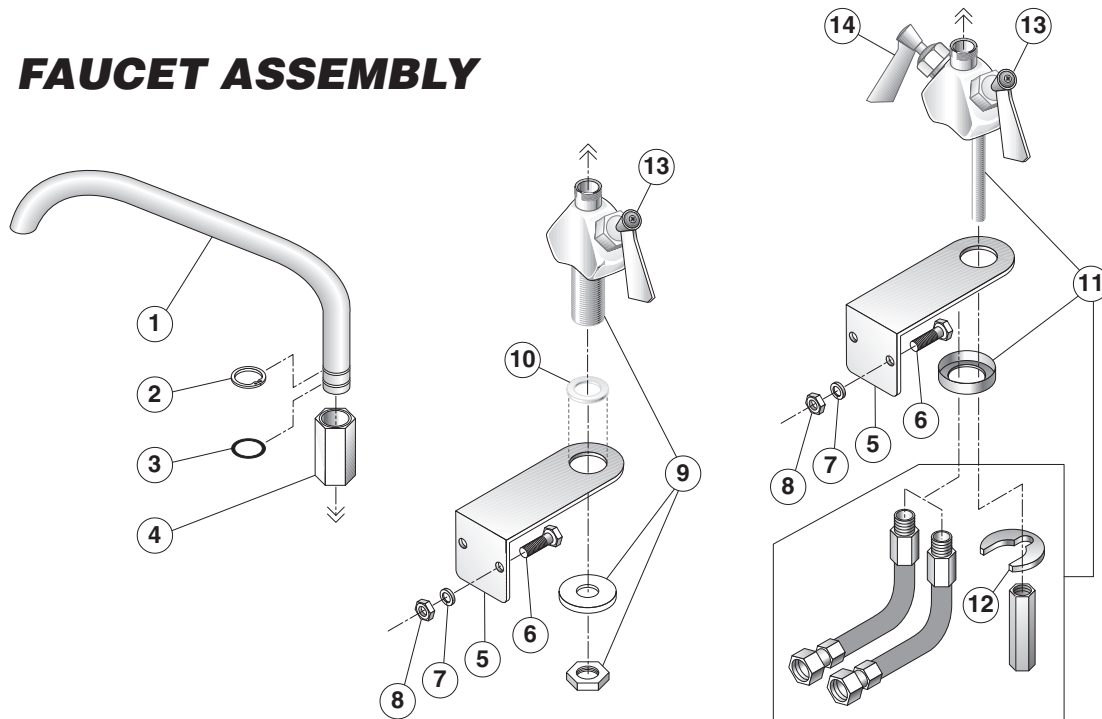

ITEM #	PART #	DESCRIPTION	QTY.
	SPK11	SINGLE PANTRY FAUCET for <u>Tilting Kettles</u> (includes items 1-10)	
	DPK11	DOUBLE PANTRY FAUCET for <u>Tilting Kettles</u> (includes items 1-8 & 11)	
	SPK5	SINGLE PANTRY FAUCET for <u>Stationary Kettles</u> (includes items 1-10)	
	DPK5	DOUBLE PANTRY FAUCET for <u>Stationary Kettles</u> (includes items 1-8 & 11)	
1.	KE50825-11	3/4" SPOUT for - SPK11 & DPK11	1
	KE50825-5	3/4" SPOUT for - SPK5 & DPK5	1
2.	FA95007-10	RETAINING RING	1
3.	FA05002-19	"O" RING	1
4.	KE51736	LONG FAUCET NUT	1
5.	KE54159	FAUCET MOUNTING BRACKET for <u>Tilting Kettles</u>	1
6.	FA11258	HEX CAP SCREW	2
7.	FA31029	LOCK WASHER	2
8.	FA210028	HEX NUT	2
9.	KE51401	SINGLE PANTRY BODY (c/w item 13)	1
10.	KE50335	ADAPTER WASHER	1
11.	KE51403	DOUBLE PANTRY BODY (c/w item 13 & 14)	1
12.	SE50447	REPLACEMENT HORSESHOE WASHER	1
13.	SE50021	REPLACEMENT STEM ASSEMBLY, COLD WATER	1
14.	SE50020	REPLACEMENT STEM ASSEMBLY, HOT WATER	1

SERVICE PARTS

SCRAPER BLADES

ITEM NO.	PART NO.	DESCRIPTION	QTY.
1.	KE54602	SCRAPER BLADE	7
2.	KE54608	SPRING	7
3.	KE01976	SPRING REMOVAL TOOL	1
COMPLETE AGITATOR ASSEMBLY			
(NOT SHOWN)	KE02286-1	60 GALLON	1
	KE02286-2	80 GALLON	1
	KE02286-3	100 GALLON	1

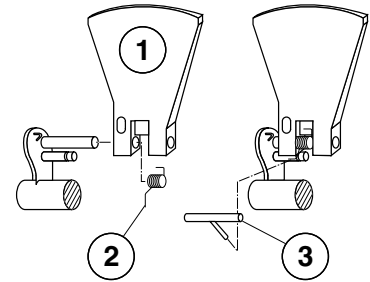

AGITATOR SEAL ASSEMBLY

ITEM NO.	PART NO.	DESCRIPTION	QTY.
1.	KE01911	RETAINING KNOBS	3
2.	KE54592	SEAL RETAINER PLATE	1
3.	FA05002-8	"O" RING	1
4.	KE54594	PIN	1
5.	KE54583	COUPLING	1
6.	KE54593	IDLER PIN	1
7.	KE54590	BUSHING	1
8.	KE54592	SEAL RETAINER PLATE	1
9.	FA05002-48	"O" RING	1
10.	KE55458	SEAL	1
11.	KE55457	SST WAVE WASHER	1
12.	KE55456	SILICONE FILLED SEAL	1
13.	KE55455	RETAINER FOR LIP SEALS	1
14.	FA11509-5	BOLT, HEX HEAD, 3/8 16 x 2 1/2	2
15.	FA31031	WASHER, 3/8 18-8	2
16.	KE600583	GREASE NIPPLE, 1/8 NPT	2

Prior to October 2003

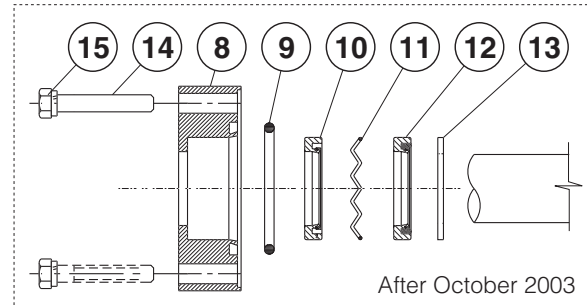
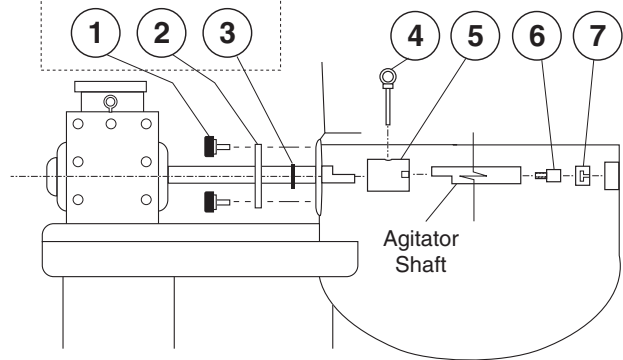

OPERATING CONTROLS

ITEM NO.	PART NO.	DESCRIPTION	QTY.
1.	KE54531	BUTTON, AGITATOR STOP	1
2.	KE54530	BUTTON, AGITATOR START	1
	KE603106	LED LAMP	1
3.	KE54529	SWITCH, AGITATOR POWER	1
4.	KE54532	SWITCH, SPEED CONTROL	1

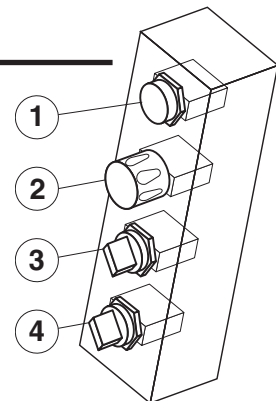

PRESSURE RELIEF ASSEMBLY

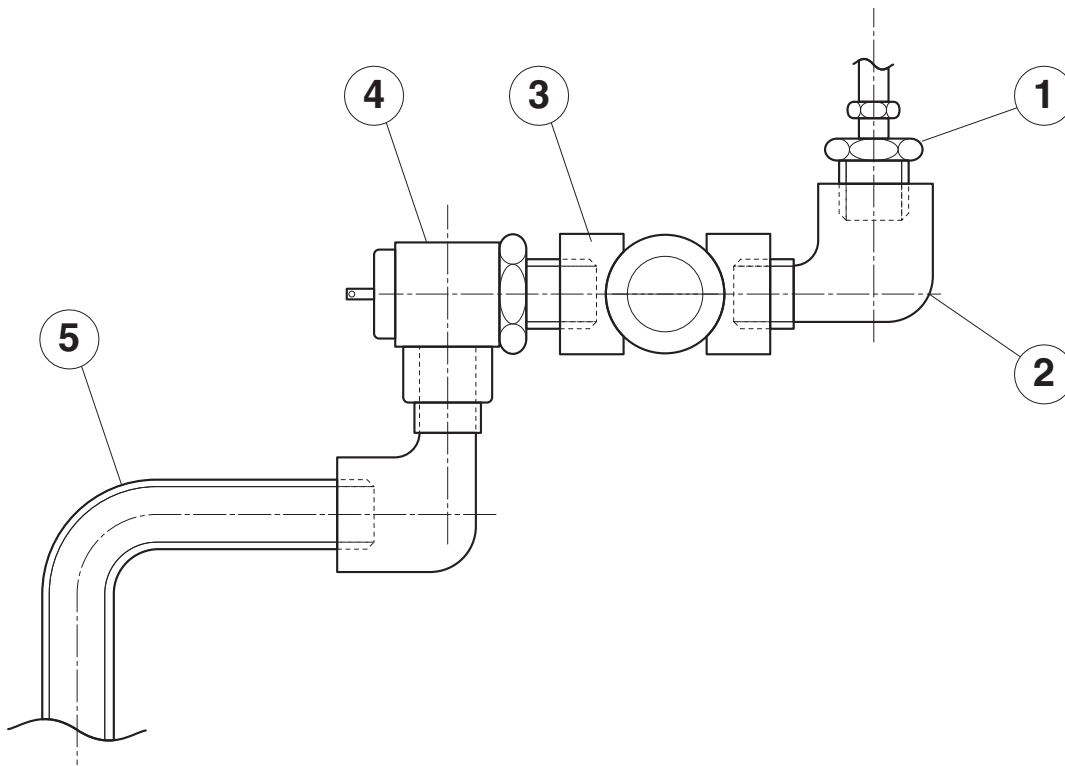

ITEM NO.	PART NO.	DESCRIPTION	QTY.
1.	FA05049	MALE CONNECTOR, 1/2" PIPE - 1/4" TUBE	1
2.	FI00151	STREET ELBOW, 1/2"	2
3.	FI00178	TEE, 1/2" FPT, BRASS	1
4.	KE54941-5	SAFETY VALVE, 50 PSI, 1/2" (NORTH AMERICA)	1
	KE54941-31	SAFETY VALVE, 50 PSI, 1/2", (EUROPE)	1
5.	KE54223	BLOW DOWN TUBE	1

SIGHT GLASS

ITEM ON.	PART NO.	DESCRIPTION	QTY.
1.	KE50955	RETAINING COVER	1
2.	KE52871	WASHER	1
3.	KE51053-1	SIGHT GLASS	1
4.	FA05002-30	"O" RING	1

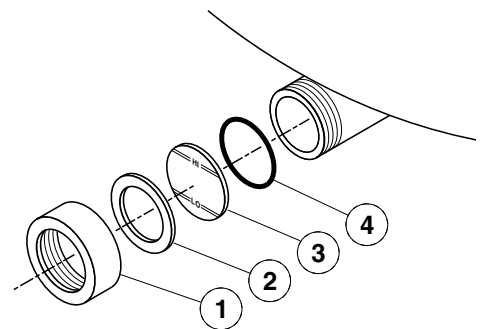

HINGE ASSEMBLY

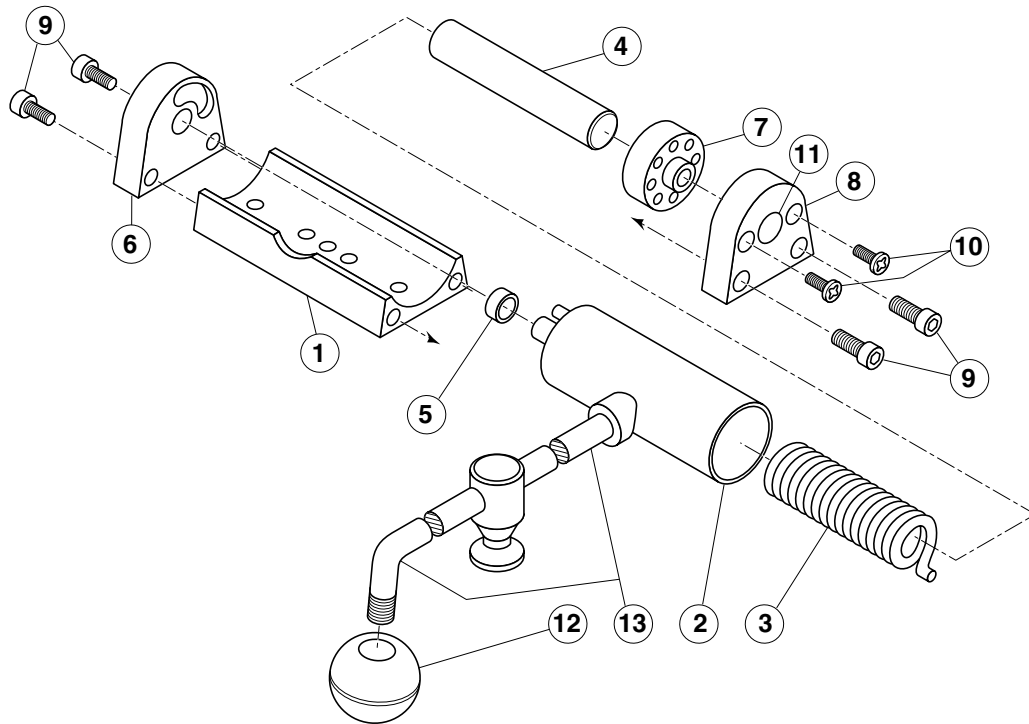

ITEM NO.	PART NO.	DESCRIPTION	QTY.
Hinge Assembly			
1. - 11	KE00597-1	25 - 40 Gallon, 20 Gallon Full Jacketed	.1
	KE00597-2	60 - 80 Gallon, 30 - 40 Gallon Full Jacketed	.1
	KE00597-3	100 - 150 Gallon, 60 - 100 Gallon Full Jacketed	.1
	KE00597-4	KDM-60, KDM-60-T, Cook Tank	.1
	KE00597-5	KDL-200, KDL-250, KDL-150-F, KDL-250-F	.1
1.	KE50822	Hinge Base	.1
2.	KE51217	Hinge Cylinder	.1
3.	KE50121-2	Hinge Spring Light - for KE00597-2	.1
	KE50121-1	Hinge Spring Heavy - for KE00597-1, KE00597-3, KE00597-4, KE00597-5, . .	.1
4.	KE50823-1	Hinge Pin	.1
5.	KE50824	Hinge Bearing	.1
6.	KE50819-1	Hinge End Piece	.1
7.	KE50820	Hinge Insert	.1
8.	KE50819	Hinge End Piece	.1
9.	FA11284	Screw, Socket Head	.4
10.	FA11507	Cutting Screw,	.2
11.	SK50418	Plug Button	.1
12.	KE50151-2	Knob	.1
13.		Cover Handle (specify model)	.1

FLUSH PISTON VALVE (USED PRIOR TO 2003)

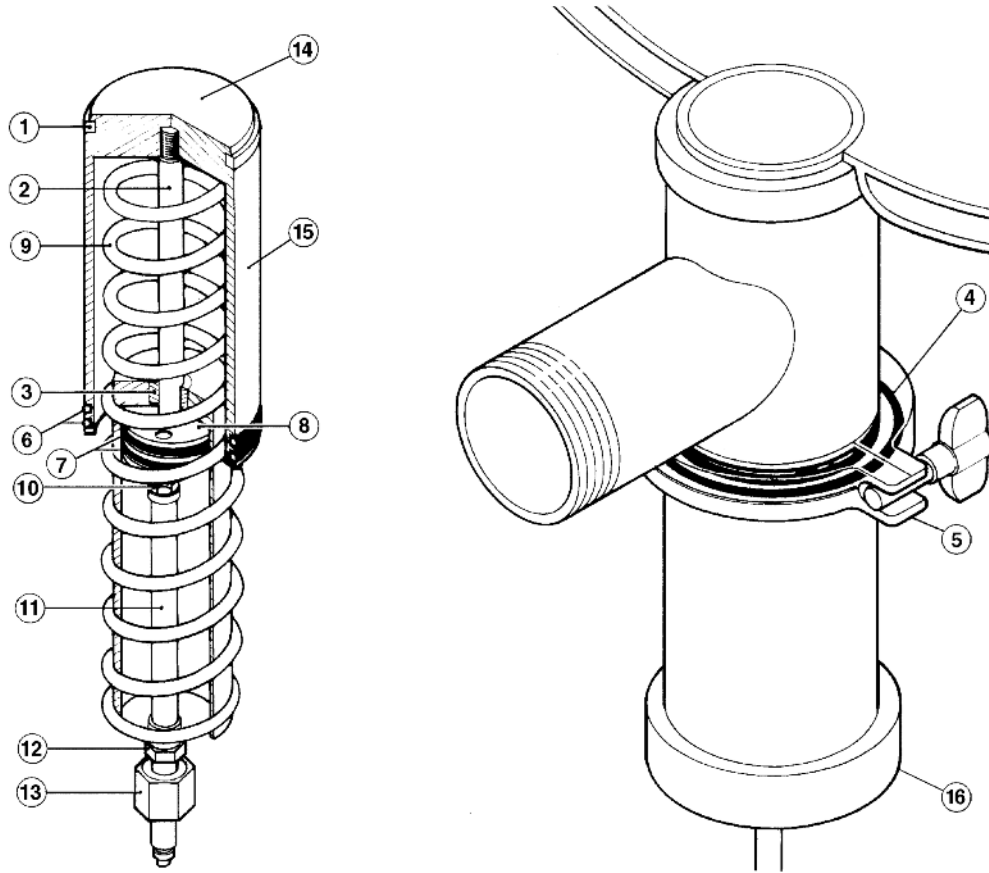

ITEM NO.	PART NO.	DESCRIPTION	QTY.
	T40430	Valve Assembly (includes parts 1 - 16)	1
1.	FA05000	"O" Ring, Cylinder Head	1
2.	KE52345	Piston Shaft	1
3.	KE52346	Air seal	1
4.	KE52347	Sani-Clamp Seal, 4"	1
5.	KE52344	Sani-Clamp, 4"	1
6.	FA05002-22	"O" Ring, Cylinder Body	2
7.	FA05002-21	"O" Ring, Piston	2
8.	KE52315	Piston	1
9.	KE52335	Compression Spring	1
10.-13.	SE00040	Supply Hose Assembly, Piston	1
10.	KE52341	Hose Barb, 1/8" x 1/4"	3
11.	KE52340	Supply Hose, 8"	1
12.	KE52342	Hose Barb, 1/4" x 1/4"	1
13.	KE52338	Quick Connect Male End	1
14.	KE52327	Piston Top	1
15.	KE52328	Piston Cylinder	1
16.	KE52314	Bottom Nut	1

FLUSH PISTON VALVE (USED AFTER 2003)

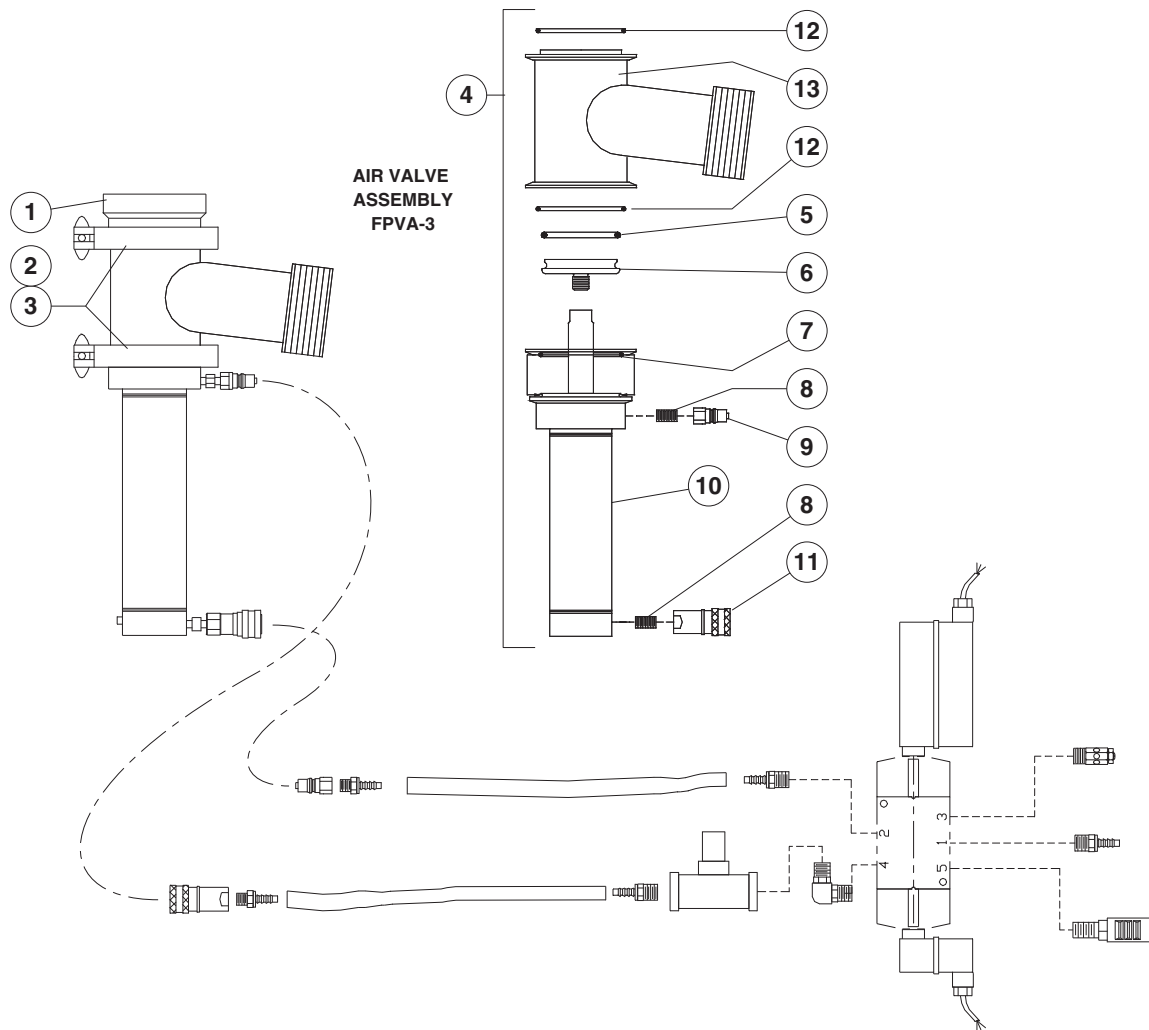

ITEM NO.	PART NO.	DESCRIPTION	QTY.
1.	KE55210	WELD RING, KETTLE BOTTOM OUTLET	1
2.	FI05144-3	SANI CLAMP, 3"	2
3.	KE52154-4	GASKET, SANI CLAMP, 3"	2
4.	KE02291	COMPLETE ACTUATOR AND DISCHARGE VALVE ASSEMBLY <i>INCLUDES PARTS 5. - 13.</i>	1
5.	KE55248	BUNA-N O-RING	1
6.	KE55249	REPLACEABLE S.S. PLUNGER HEAD	1
7.	KE55250	BUNA-N O-RING	1
8.	KE55251	1/8 NPT S.S. HYDRAULIC CLOSE NIPPLE	2
9.	KE55252	MALE S.S. QUICK DISCONNECT	1
10.	KE55253	AIR OPERATED CYLINDER	1
11.	KE55254	FEMALE S.S. QUICK DISCONNECT	1
12.	FA05002-53	BUNA-N O-RING	2
13.	KE55256	FEMALE S.S. QUICK DISCONNECT	1

PNEUMATICS (USED PRIOR TO 2003)

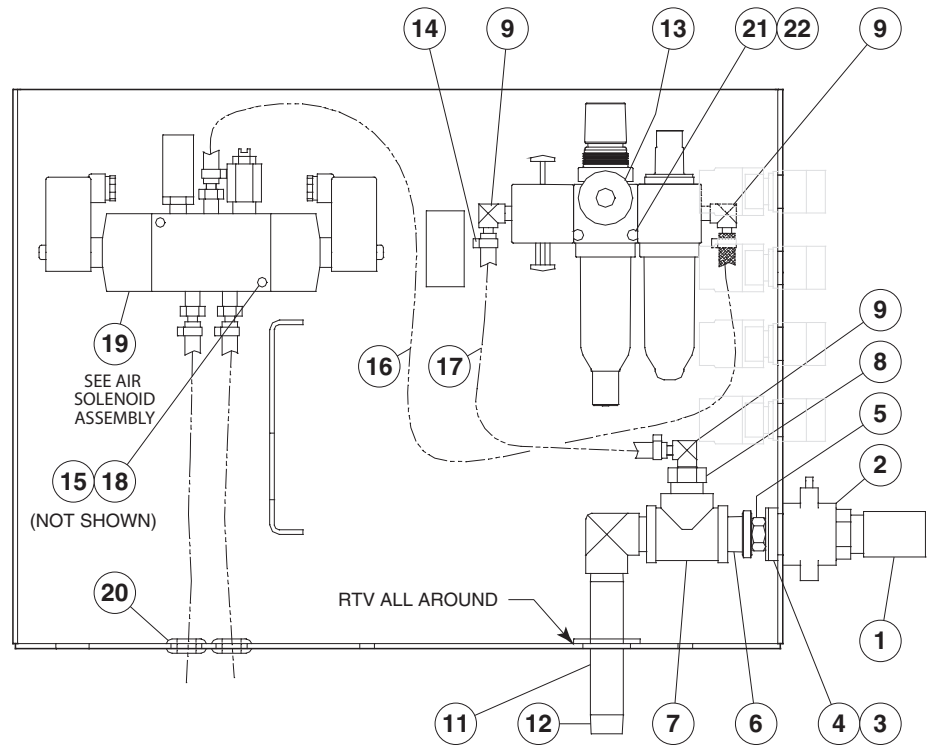

ITEM NO.	PART NO.	DESCRIPTION	QTY.
1.	KE601603	QUICK CONNECT	1
2.	KE54280	SLIDE VALVE	1
3.	FA30512	SPACER WASHER	1
4.	FA32500	TOOTH LOCK WASHER 7/8" DIA.	1
5.	KE52697	NUT 1/2 NPS BRASS	1
6.	KE52931	AIR FITTING	1
7.	F100178	TEE 1/2 NPT	1
8.	FI00351	BUSHING 1/2 MIP X 1/4 FIP	1
9.	FI05318	HOSE BARB 90° ELBOW	3
10.	FI00151	90° STREET ELBOW 1/2 NPT	1
11.	FA30090	WASHER 15/16 ID X 1 3/4 OD X 1/8	1
12.	7100595-8	NIPPLE 1/2 NPT X 4 1/2" LONG	1
13.	KE55238	FILTER-REGULATOR-LUBRICATOR BLOCK	1
14.	F105220-1	GEAR CLAMP	4
15.	FA21006	10-24 S.S. NUT	2
16.	KE532177	PNEUMATIC HOSE 1/4 I.D. X 31" L	1
17.	KE532176	PNEUMATIC HOSE 1/4 I.D. X 12 1/2" L	1
18.	FA30000	FLAT WASHER #10, ZINC PLATED	2
19.	KE02292	AIR SOLENOID ASSEMBLY (SEE SOLENOID ASSEMBLY DRAWING)	1
20.	KE50555-3	GROMMET	2
21.	FA21008	1/4-20 NUT S.S.	2
22.	FA30002	FLAT WASHER 1/4 DIA., ZINC PLATED	2

PNEUMATICS (USED AFTER 2003)

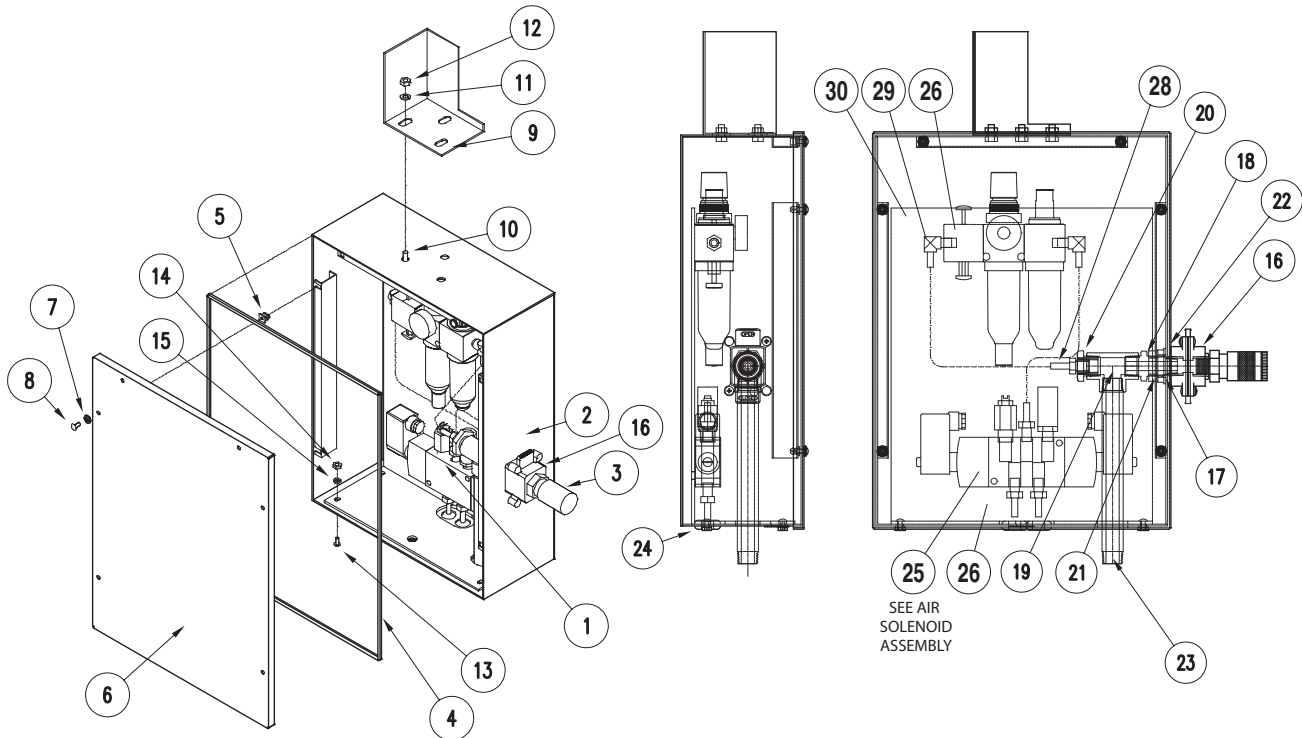

ITEM NO.	PART NO.	DESCRIPTION	QTY.
1	KE02296	PNEUMATIC ASSEMBLY	1
2	KE02299	PNEUMATIC BOX WELDMENT	1
3	F105166	QUICK CONNECTOR, 3/8	1
4	KE54846-8	GASKET, U-CHANNEL	1
5	FA95074	NYLON ANCHOR NUT, #8 THREADED HOLE	6
6	KE55241	COVER, PNEUMATIC BOX	1
7	KE55242	SEALING WASHER, #8	6
8	FA11091	S.S. SCREW, #8-32 X 3/8, BINDING HD	6
9	KE55243	MOUNTING BRACKET, PNEUMATIC BOX	1
10	FA11255	S.S. HEX HEAD SCREW, 1/4-20 X 3/8	3
11	FA30034	1/4 FLAT WASHER	3
12	FA21008	S.S. NUT, 1/4-20	3
13	FA11134	S.S. SCREW #10-24 X 3/8, PAN HEAD	4
14	FA21006	S.S. NUT, #10-24	4
15	FA30000	WASHER, #10	4
16	KE54280	SLIDE VALVE	1
17	FA30512	SPACER WASHER	1
18	KE52931	AIR FITTING.	1
19	KE600814-1	TEE 1/2 NPT, BRASS, FIP X FIP X FIP	1
20	FI05047	BUSHING, REDUCER, 1/2 NPT X 1/4 NPT	1
21	KE52697	NUT, 1/2 NPT BRASS	1
22	FA32500	LOCKWASHER, INTERNAL TOOTH, 7/8	1
23	F100595-16	NIPPLE, 1/2 NPT BRASS	1
24	KE50555-3	GROMMET	2
25.	KE02292	AIR SOLENOID ASSEMBLY (SEE SOLENOID ASSEMBLY DRAWING)	1
26.	KE55238	FILTER - REGULATOR - LUBRICATOR BLOCK	1
27.	KE55239	MOUNTING PLATE, PNEUMATIC ASSEMBLY	1
28.	FI05317-2	HOSE BARB, MALE, 1/4 NPT X 1/4 HOSE	1
29.	FI05167	HOSE BARB, 90° ELBOW	1
30.	FI05220-1	GEAR CLAMP, 1/4 HOSE	1
31.	KE53217-6	PNEUMATIC HOSE, 1/4 I.D. X ~12 LONG	1

AIR SOLENOID ASSEMBLY

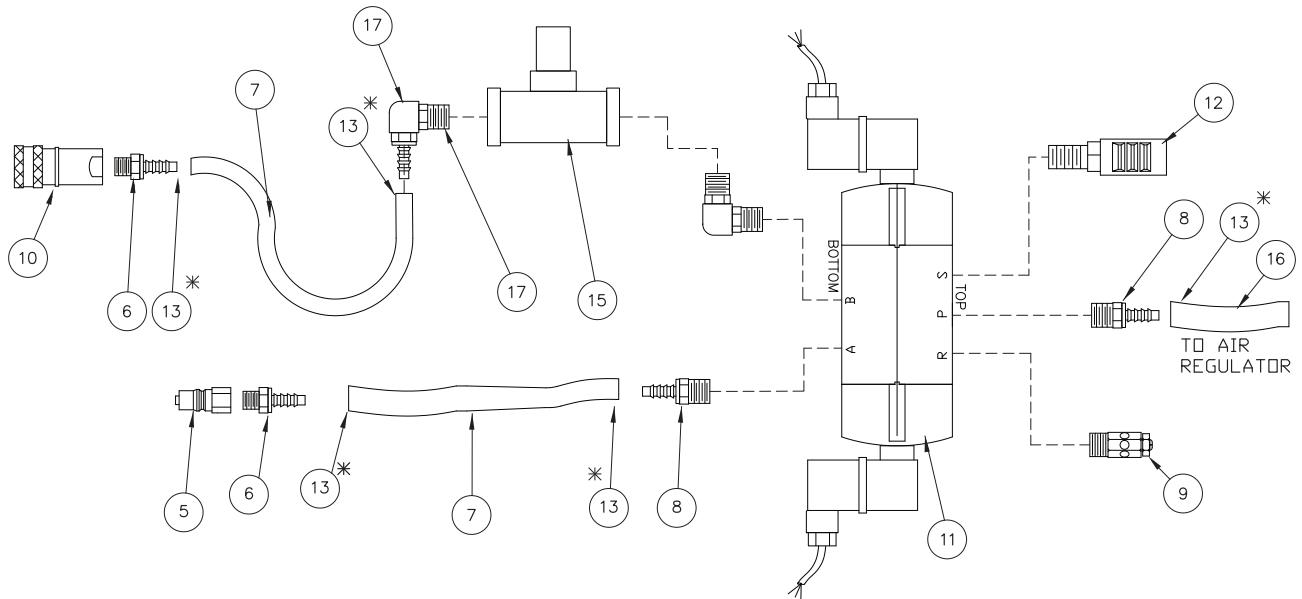

ITEM NO.	PART NO.	DESCRIPTION	QTY.
5	KE55257	MALE QUICK PLUG	1
6	FI05317-1	HOSE BARB 1/8" NPT MALE TO 1/4" HOSE	2
7	KE55259-1	1/4" ID X 6 FT. LONG HOSE 250 #W,P,	2
8	FI05317-2	HOSE BARB 1/4" NPT MALE TO 1/4" HOSE	2
9	KE55261-1	SPEED EXHAUST MUFFLER 1/8"	1
10	KE55262	FEMALE QUICK PLUG	1
11	KE55263-1	5 WAY AIR SOLENOID VALVE	1
12	KE55264-1	STANDARD 1/8" MUFFLER	1
13	FI05220-1	GEAR CLAMP FOR 1/4 I.D. HOSE (NOT SHOWN)	5
14	FI05030-2	90° 1/4 ELBOW, MALE PIPE THREAD	1
15	KE55305	1/4" FLOW CONTROL	1
16	KE55259-2	1/4" ID X 3 FT. LONG HOSE 250 #W,P,	1
17	FI05318	90° ELBOW HOSE BARB, 1/4 HOSE I.D. X 1/4 PIPE, BRASS	1

TEMPERATURE SENSOR

(USED PRIOR TO JUNE 2005)

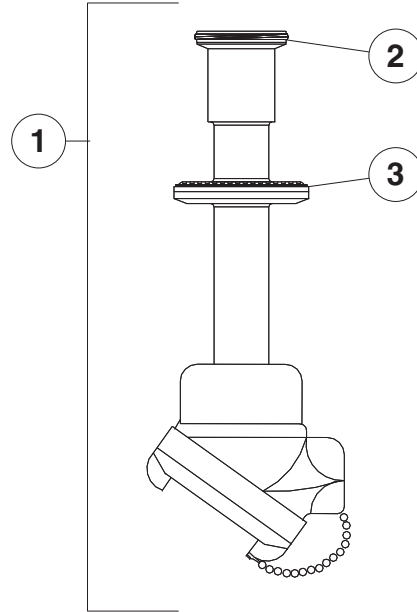

ITEM NO.	PART NO.	DESCRIPTION	QTY.
1.	KE54924	TEMPERATURE SENSOR ASSEMBLY	1
2.	FA05002-46	O-RING, FOOD GRADE, SIZE A0123, EPDM E 692-75	1
3.	KE52154-3	GASKET, SANI CLAMP, 1 1/2" WHITE TEFLON	1

TEMPERATURE SENSOR

(USED AFTER JUNE 2005)

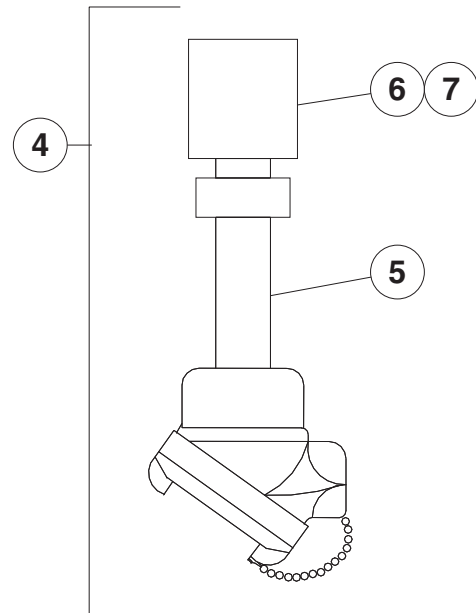

ITEM NO.	PART NO.	DESCRIPTION	QTY.
4.	KE54924-1	TEMPERATURE SENSOR ASSEMBLY	1
5.	KE54924-2	SENSOR MAIN BODY	1
6.	KE54924-3	TANK MOUNTING ADAPTOR	1
7.	FA05002-23	SENSOR O-RING	1

GEARMOTOR - ELECTRICAL ASSEMBLY

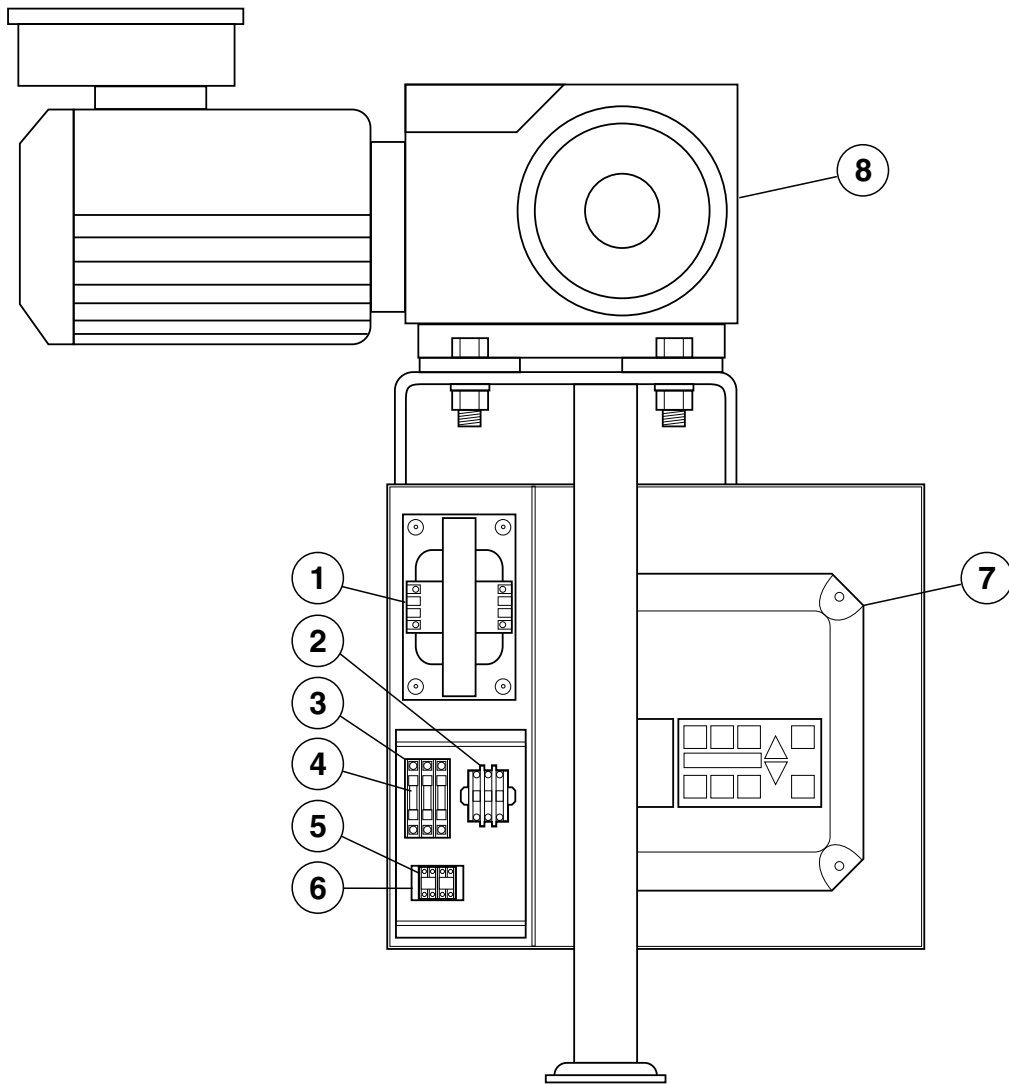

ITEM NO.	PART NO.	DESCRIPTION	QTY.
1.	KE53838-2	TRANSFORMER, 200-240V/440-480V	1
2.	KE50750-2	CONTACTOR	1
3.	KE51139-1	FUSE HOLDER	3
4.	KE52936-18	15A FUSE, KLKR	3
5.	PR50003	TERMINAL BLOCK	
6.	PR50005	TERMINAL BLOCK BRACKET	1
7.	KE54528	A.C. INVERTER	1
8.	KE54527-1	GEAR MOTOR, 200V/340V	1
	KE54527-2	GEAR MOTOR, 230V/460V	1

ELECTRICAL COMPONENT BOX

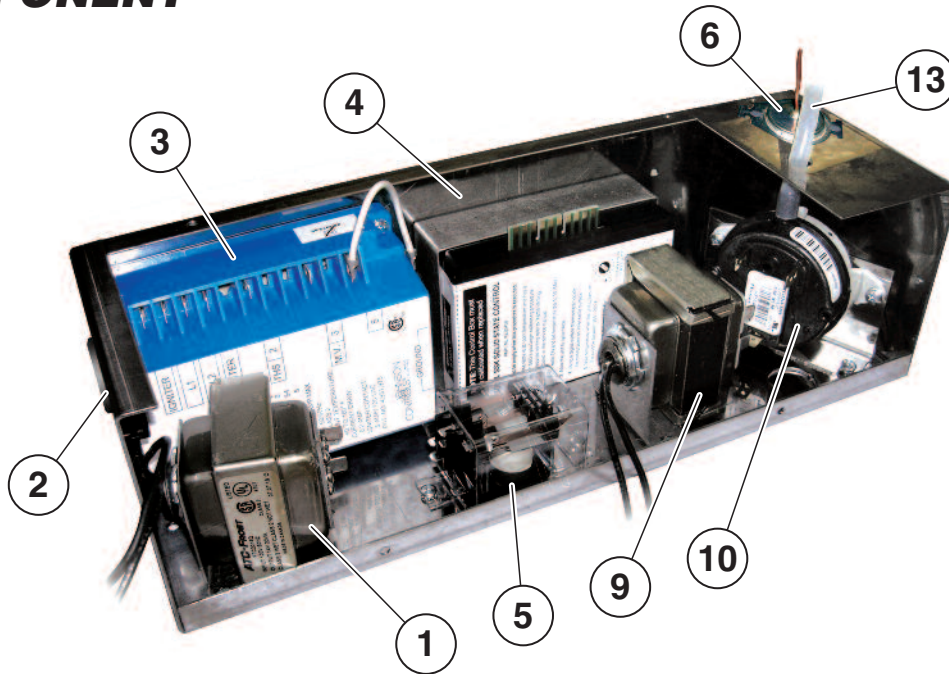

ITEM NO.	PART NO.	DESCRIPTION	QTY.
	KE01422	ELECTRICAL CONTROL BOX ASSEMBLY	1
	KE53439	COMPONENT BOX	1
	KE53440	COVER, COMPONENT BOX	1
	KE53599-1	GASKET	1
1.	KE53838-27	TRANSFORMER, 120-14V.	1
	KE53444	TRANSFORMER BRACKET	1
2.	KE54833-3	SNAP-IN BUSHING, 0.875" DIA.	1
3.	KE02372	IGNITION MODULE, PRIOR TO SEPT. 2004	1
	KE53469-4	IGNITION MODULE, SEPT. 2004 AND AFTER	1
4.	KE00458	KETTLE SOLID STATE CONTROL BOX	1
	KE50303	BRACKET, SOLID STATE CONTROL BOX	1
5.	KE50753-7	RELAY, 12V SPDT (FOR 60 CYCLE, 120V UNITS)	1
	KE50753-8	RELAY, 12V DPDT (FOR 50 CYCLE, 240V UNITS)	1
6.	KE55069-6	SAFETY THERMOSTAT	1
7.	FI05050	BRASS NUT, 7/16-24, PRIOR TO SEPT. 2004	1
9.	KE53838-20	TRANSFORMER 120-24V	1
10.	KE02400	AIR SWITCH, PRIOR TO SEPT. 2004	1
	KE55453-1	AIR SWITCH, SEPT. 2004 AND AFTER	1
13.	KE53582	TUBING 1/4 INCH SILICONE	
Not Shown	KE53523	TUBING 1/4 INCH COPPER, PRIOR TO SEPT. 2004	

COMPONENT PLATE ASSEMBLY - POWER TILT

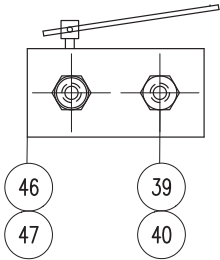
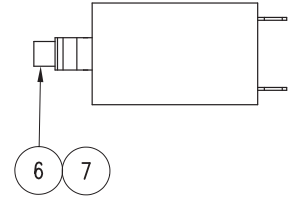
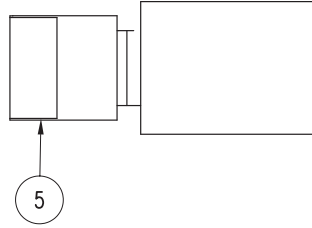
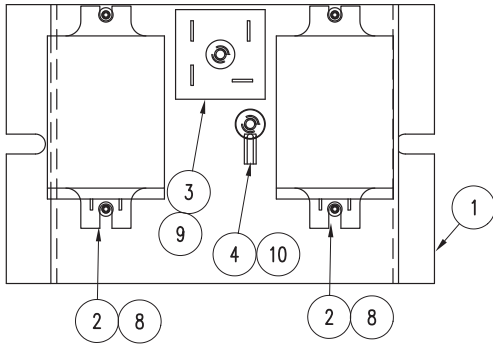

VOLTS OPTION	PART NUMBER	COMMON PARTS COMPONENT PLATE ASS'Y		TRANSFORMER ITEM # 48	
		PART #	QTY.	PART #	QTY.
208V	KE02185-11	KE02185-5	1	KE53838-10	1
240V-480V	KE02185-12	KE02185-5	1	KE53838-12	1
380V	KE02185-13	KE02185-5	1	KE53838-11	1
575V	KE02185-15	KE02185-5	1	KE53838-13	1

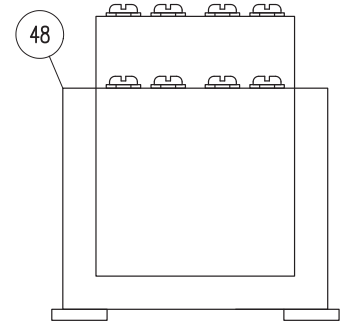

ITEM NO.	PART NO.	DESCRIPTION	QTY.
-----------------	-----------------	--------------------	-------------

COMMON PARTS

1	KE50343-16	COMPONENT PLATE	.1
2	KE50753-10	RELAY, 10A/120V	.2
3	KE50581	BRIDGE RECTIFIER	.1
4	KE50473	GROUND LUG	.1
5	KE003209-11	SWITCH, POWER TILT	.1
6	KE50579-1	CIRCUIT BREAKER, 1.5A	.1
7	KE50580	WATER RESISTANT BOOT	.1
8	FA11051	6-32 X 3/16 PAN PHIL S.S.	.4
9	FA11091	8-32 X 3/8 PAN PHIL S.S.	.1
10	FA11089	8-32 X 1/4 PAN PHIL S.S.	.1
11*	NPNO0158	FULLY INSULATED NYLON MALPLER	.3
12*	KE52289-3	#8 SPADE	.4
13*	NPNO0143	TERMINAL, FLAG SLIP-ON	.12
14*	NPNO0158-1	WIRE COUPLER	.2
15*	KE52295	TERMINAL, FLAG SLIP-ON	.4
16*	NPN00009	WIRE JOINT PIGTAIL	.1
17*	NPNO0103	FULL INSULATED PUSH ON TERMINAL	.3
18*	NPN00020	CABLE TIE HOLDER	.5
19*	K E51627	CABLE TIE 5 1/2"	.7
20*	RB01551	BLACK SLEEVING, SIZE 2, HO, L 136"	.1
39*	FA20002	HEX NUT 6-32	.2
40	FA11060	SCREW 6-32 X 1	.2
46	KE51007	MICRO SWITCH, HONEYWELL	.2
47	KE50498	MICRO SWITCH INSULATION	.2
48	(SEE CHART)	TRANSFORMER	.1

* ITEMS NOT SHOWN

KETTLE - GAS COMPONENTS

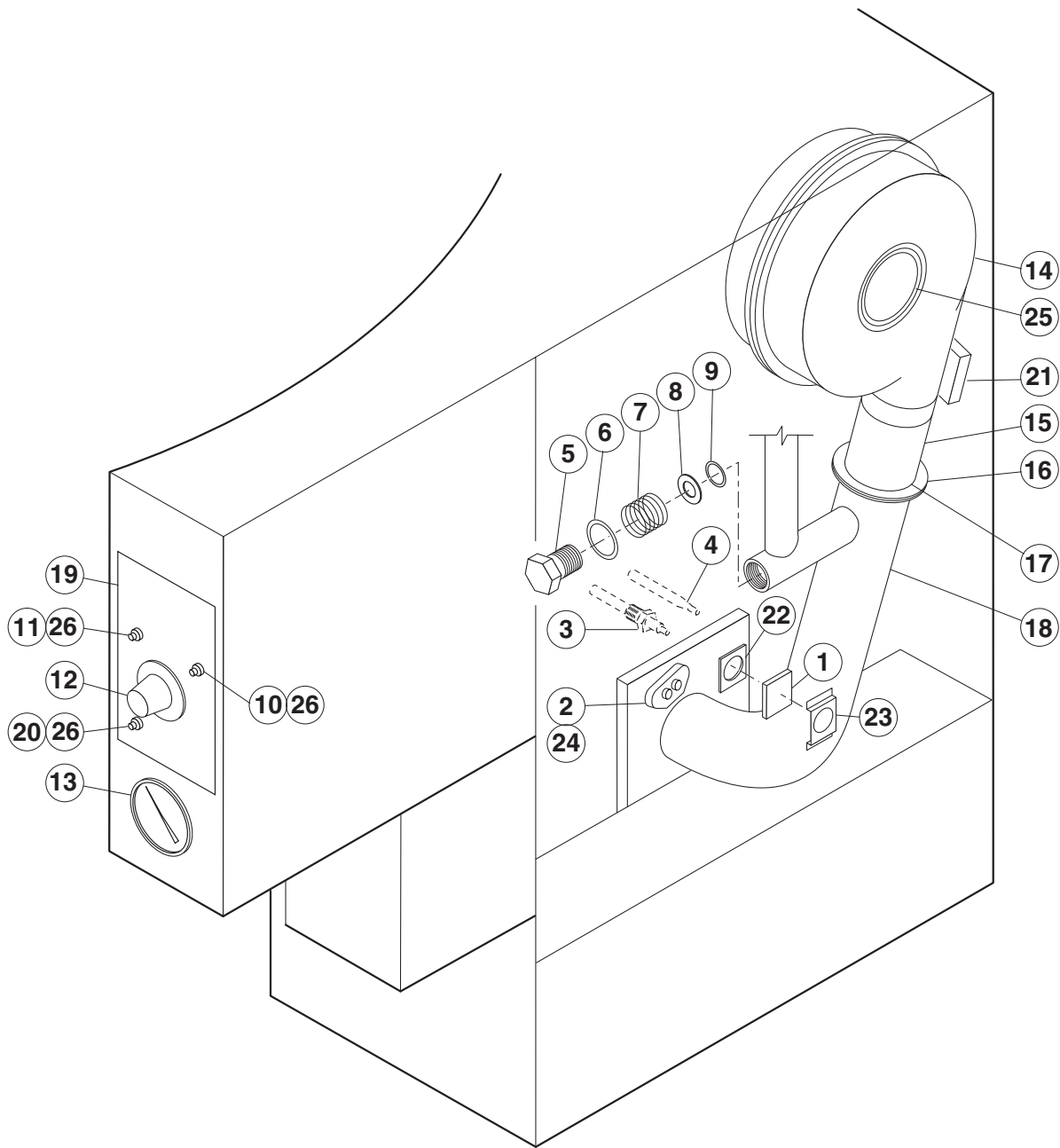

KETTLE - GAS COMPONENTS

ITEM NO.	PART NO.	DESCRIPTION	QTY
1.	KE53617	SIGHT GLASS	1
2.	KE53437	IGNITOR	1
3.	KE50556-2	WATER LEVEL PROBE	1
4.	KE00515	THERMISTOR	1
5.	FI05213	PLUG	1
6.	FA05002-4	"O" RING	1
7.	KE53422	SPRING	1
8.	GAS ORIFICE:		
	KE53403-6	NATURAL GAS - SEA LEVEL TO 2000'	1
	KE53403-7	PROPANE GAS - SEA LEVEL TO 2000'	1
	KE53403-10	NATURAL GAS - 2000' TO 4000'	1
	KE53403-11	PROPANE GAS - 2000' TO 4000'	1
	KE53403-10	NATURAL GAS - 4000' TO 6000'	1
	KE53403-14	PROPANE GAS - 4000' TO 6000'	1
	KE53403-17	NATURAL GAS - 6000' TO 8000'	1
	KE53403-18	PROPANE GAS - 6000' TO 8000'	1
	KE53403-17	NATURAL GAS - 8000' TO 10,000'	1
	KE53403-22	PROPANE GAS - 8000' TO 10,000'	1
9.	FA05002-29	"O" RING	1
10.	KE50568-1	L.E.D. GREEN	1
11.	KE50567-1	L.E.D. RED	1
12.	TEMPERATURE CONTROL ASSEMBLY:		
	KE50569-1	KNOB	1
	SE00114	POTENTIOMETER WITH ON/OFF SWITCH, C/W SEAL	1
	KE51005	SEAL	1
13.	KE50429-2	PRESSURE GAUGE	1
14.	KE53441	BLOWER, 110 V, 60 HZ	1
15.	KE53441-1	BLOWER, 220 V, 50 HZ	1
16.	KE01426-1	MIXING CHAMBER, 60 GALLON KETTLES	1
17.	KE53402-1	AIR ORIFICE, 190K BTU BURNER	1
18.	FI05212	PIPE	1
19.	KE95087-1	OPERATING INSTRUCTION LABEL	1
20.	KE50567-2	L.E.D. AMBER (USED PRIOR TO JULY 2004)	1
21.	KE02274	CAPACITOR ASSEMBLY	1
22.	KE53618	SIGHT GLASS GASKET	1
23.	KE53619	SIGHT GLASS RETAINER	1
24.	KE53570	GASKET FOR IGNITOR	1
25.	KE54420	AIR INTAKE WASHER (NATURAL GAS)	1
	KE54420-1	AIR INTAKE WASHER (PROPANE)	1
26.	FA05002-18	"O" RING	3

ASSEMBLY DRAWING

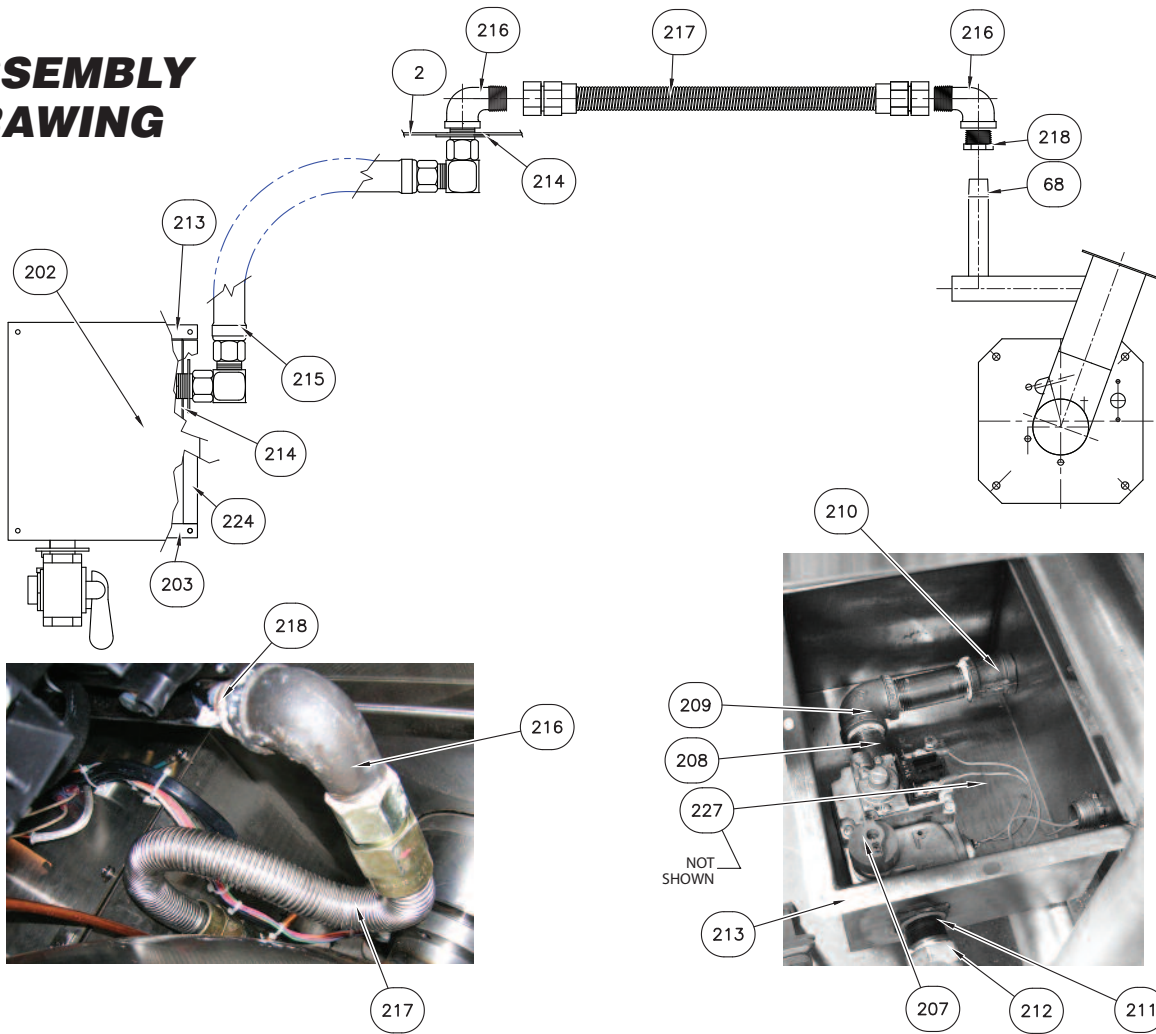

ITEM NO.	PART NO.	DESCRIPTION	QTY
202	KE602791	COVER - GAS VALVE BOX,	1
203	KE53599-18	GASKET	2
207	KE53515	GAS VALVE	1
208	N0640B3	SPECIAL NIPPLE	2
209	FI00063	ELBOW 90 DEG. BRASS	1
210	FI00267	3/4" COUPLING, BRASS	1
211	N0640C1.5	3/4" X 1 1/2 NIPPLE, BLK. IRON	1
213	KE602790	GAS VALVE BOX	1
214	KE54606	GAS VALVE LOCK WASHER	2
215	SK2472703	GAS CONNECTOR HOSE (60/80/100 GAL)	1
216	FI00134	3/4" ELBOW, 90° STREET	2
217	KE602899	GAS CONNECTOR HOSE	1
218	FI05231	BUSHING, REDUCER, 3/4"-1/2" NPT	1
221	KE51900	3/8 LIQUID TITE CONNECTOR, 90°	1
224	KE53599-19	GASKET	2
225	KE602902	BRACKET CONDUIT CONNECTOR	1
226	FA30088	WASHER	1
227	KE52000-1	MESH	1
228	KE602987-1	WASHER GEAR SIDE	1
229	KE602987-2	WASHER SIDE BOX	1
230	SK2472702	3/4" SWIVEL GAS FITTING	2

GEAR BOX ASSEMBLY

(Used prior to December 2006)

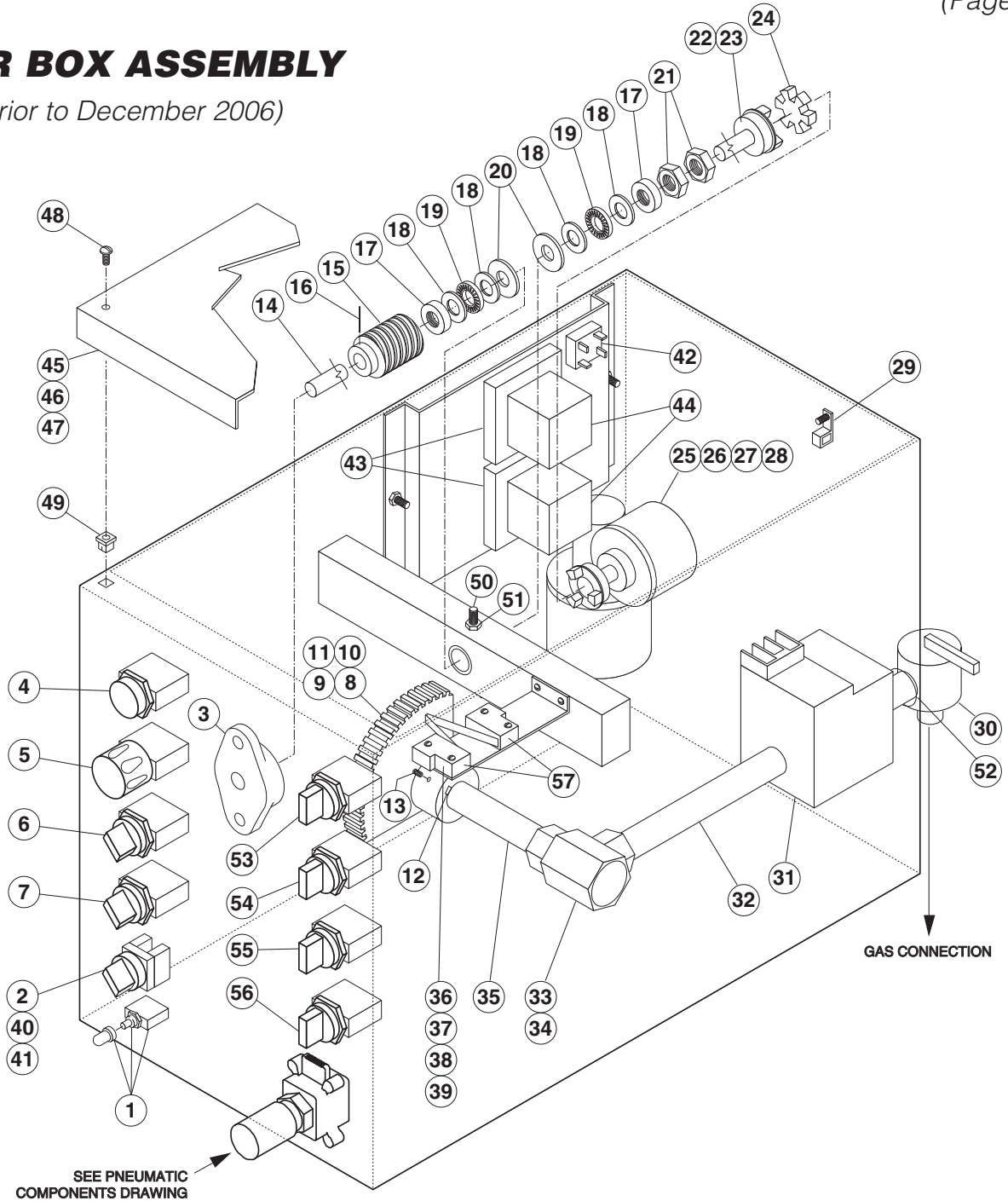

ITEM NO.	PART NO.	DESCRIPTION	QTY.
1.	KE50579-1	CIRCUIT BREAKER, RESET	1
	FA00012	"O" RING, CIRCUIT BREAKER	1
	KE50580	WATER RESISTANT BOOT	1
2.	KE603208-4	TILT SWITCH	1
3.	KE51730	TILT SHAFT BEARING	1
4.	KE54531	BUTTON, AGITATOR STOP	1
5.*	KE54530	BUTTON, AGITATOR START	1
	KE603106	LED LAMP	1
6.*	KE54529	SWITCH, AGITATOR POWER	1
7.*	KE54532	SWITCH, SPEED CONTROL	1

GEAR BOX ASSEMBLY*(Used prior to December 2006)*

8.	KE01889	MICRO SWITCH TRIGGER/SEGMENT GEAR WELDMENT	.1
9.	FA10772	SOCKET HD. CAP SCREW	.2
10.	FA20048	JAM NUT	.2
11.	FA95007-4	RETAINING RING	.1
12.	FA95055-1	SQUARE KEY	.1
13.	FA19201	HEX SOCKET SET SCREW 3/8-24	.1
14.	KE54644	TILT SHAFT, MANUAL TILT	.1
	KE52836-2	TILT SHAFT, POWER TILT	.1
15.	KE50315	WORM	.1
16.	FA95005	TENSION PIN	.1
17.	KE52193-1	THRUST BEARING SPACER	.2
18.	KE52192	THRUST WASHER	.4
19.	KE52191	ROLLER BEARING	.2
20.	FA30088	WASHER	.2
21.	FA95008	JAM NUTS	.2
22.	KE50582	CPLG. ONTARIO BELTING #G-100 5/8 BORE	.2
23.	FA95055-6	SQUARE KEY 3/16 X 3/16 X 1" LG	.1
24.	KE50583	RUBBER INSERT, ONTARIO BELTING "BUNA N"	.1
25.	KE52832-1	GEARMOTOR	.1
26.	FA10487	HEX HD SCREW 1/4-20 X 1" LG	.4
27.	FA31008	SPLIT LOCKWASHER 1/4" DIA	.4
28.	FA20026	HEX NUT 1/4 - 20	.4
29.	KE50473	GROUND LUG	.1
30.	FO1518-1	GAS SHUT-OFF VALVE	.1
31.	KE02053	COMBINATION GAS VALVE NATURAL GAS	.1
32.	FI05223-1	SPECIAL NIPPLE	.1
33.	FI05222	SWIVEL ELBOW	.1
34.	FI05231	FLUSH BUSHING 3/4M TO 1/2 F	.1
35.	FI05226-11	NIPPLE 1/2 X 10" LG	.1
36.	KE51007	MICRO SWITCH	.2
37.	FA10139	MACHINE SCREW #6-32 X 1" LG	.4
38.	KE50498	MICRO SWITCH INSULATION	.2
39.	FA32004	TOOTH LOCK WASHER #6	.4
40.	KE603208-7	CONTACT SECTION HOLDER (LATCH)	.1
41.	KE603208-9	CONTACT BLOCK	.4
42.	KE50581	BRIDGE RECTIFIER	.1
43.	KE54535	EDGE CONNECTOR (11 PIN)	.2
44.	KE50753-10	RELAY	.2
45.	KE54491	LID FOR GEARBOX	.1
46.	KE53599-8	GASKET	.2
47.	KE53599-9	GASKET	.2
48.	FA95062	PAN HD. PHILLIPS SCREW	.4
49.	FA95074	NYLON ANCHOR NUT	.1
50.	FA19177	HEX SOCKET SET SCREW 5/16-24 X 1"	.1
51.	FA20047	JAM NUT 5/16-24	.1
52.	KE54606	GAS VALVE LOCKWASHER	.1
53.	KE003209-9	SWITCH, PRODUCT DISCHARGE VALVE	.1
54.*	KE003209-6	SWITCH, FILL INTERRUPT	.1
55.*	KE003209-2	SWITCH, POTABLE FILL WATER	.1
56.*	KE003209-7	SWITCH, FILL CYCLE	.1
57.	SK2474501	LIMIT SWITCH	.2

* SWITCHES MAY BE LOCATED ON REMOTE CONTROL PANEL.

GEAR BOX ASSEMBLY

(Used after December 2006)

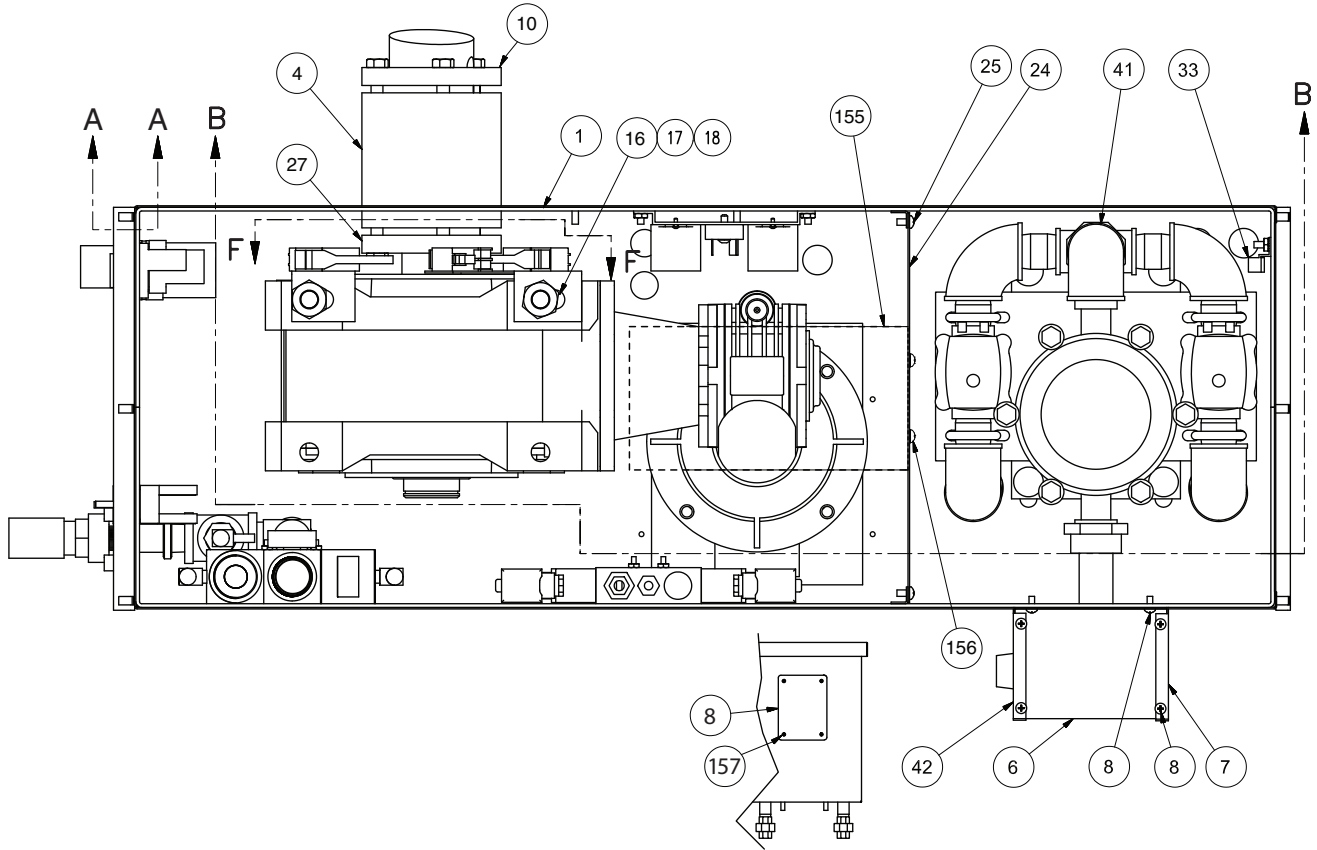

ITEM NO.	PART NO.	DESCRIPTION	QTY.
1	KE000852	GEARBOX CONSOLE WELDMENT	1
4	KE602802-1	RIGID COUPLING	1
6	KE55350	SIDE BOX, FILLER HOSE	1
7	KE55351-2	COVER, FILLER BOX	1
8	FA11091	MACHINE SCREW 8-32 X 3/8, S.S.	12
10	KE602802-2	1 3/4 BORE SPLIT TAPER BUSHING	1
16	FAT 1509-3	HEX BOLT S.S. 1/2-13 X 1 3/4	6
17	FA20032	HEX NUT S.S. 1/2-13	6
18	FA31033	SPLIT LOCKWASHER S.S. 1/2	6
24	KE600964	PARTITION PLATE	1
25	FA11145	MACHINE SCREW 10-32 X 3/8, S.S.	8
27	KE602802-3	2 1/2 BORE SPLIT TAPER BUSHING	1
33	KE50473	GROUND LUG	1
41	KE02289	PLUMBING ASSEMBLY, WATER METER	1
42	KE55351-2	COVER, FILLER BOX	1
155	KE003608	COMPONENT ASSEMBLY	1
156	FA11525-1	SEMS HEAD SCREW 10-32 X 3,8	2
157	KE603731	COVER PLATE	1

GEAR BOX ASSEMBLY

(Used after December 2006)

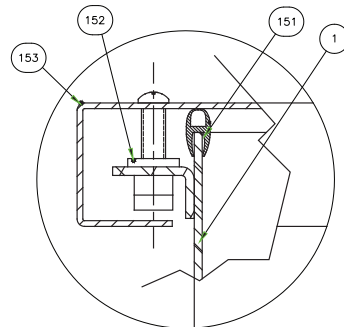

SECTION A-A

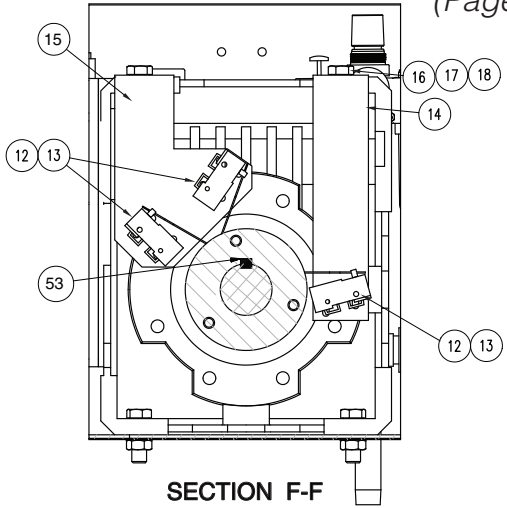

SECTION F-F

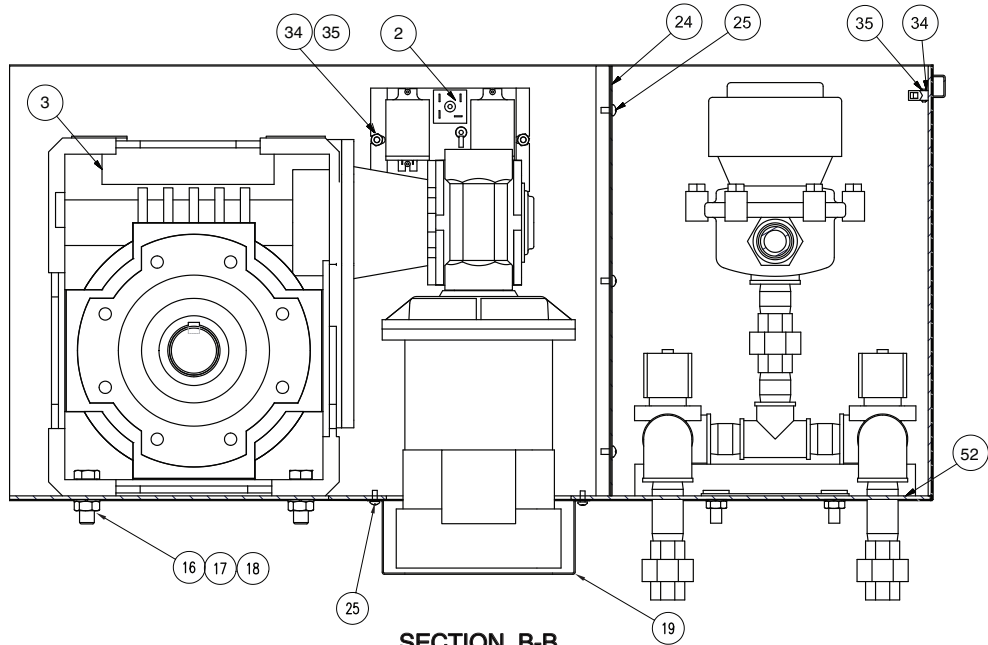

SECTION B-B

ITEM NO.	PART NO.	DESCRIPTION	QTY.
1	KE000852	GEARBOX CONSOLE WELDMENT	1
2	KE02185	COMPONENT PLATE, POWER TILT, KETTLE	1
3	KE601342	DOUBLE WORM GEARED MOTOR	1
12	SK2474501	LIMIT SWITCH	3
13	FA10140	6-32 X 1 1/4 SCREW	6
14	KE602798	LIMIT SWITCH BRACKET	1
15	KE602799	2 LIMIT SWITCH BRACKET	1
16	FAT 1509-3	HEX BOLT S.S. 1/2-13 X 1 3/4	6
17	FA20032	HEX NUT S.S. 1/2-13	6
18	FA31033	SPLIT LOCKWASHER S.S. 1/2	6
19	KE602793	MOTOR BOTTOM BOX	1
24	KE600964	PARTITION PLATE	1
25	FA11145	MACHINE SCREW 10-32 X 3/8, S.S.	8
34	FA32022	EXTERNAL TOOTH LOCK WASHER #10	3
35	FA21006	HEX MACHINE SCREW NUT UNC, 10-24, S.S.	3
52	KE601213	COVER SHEET	1
53	KE55395	3/8 SQUARE KEY	1
151	KE55515	GASKET	1
152	FA95074	NYLON ANCHOR	6
153	KE601135	COVER, GEARBOX	1

GEAR BOX ASSEMBLY

(Used after December 2006)

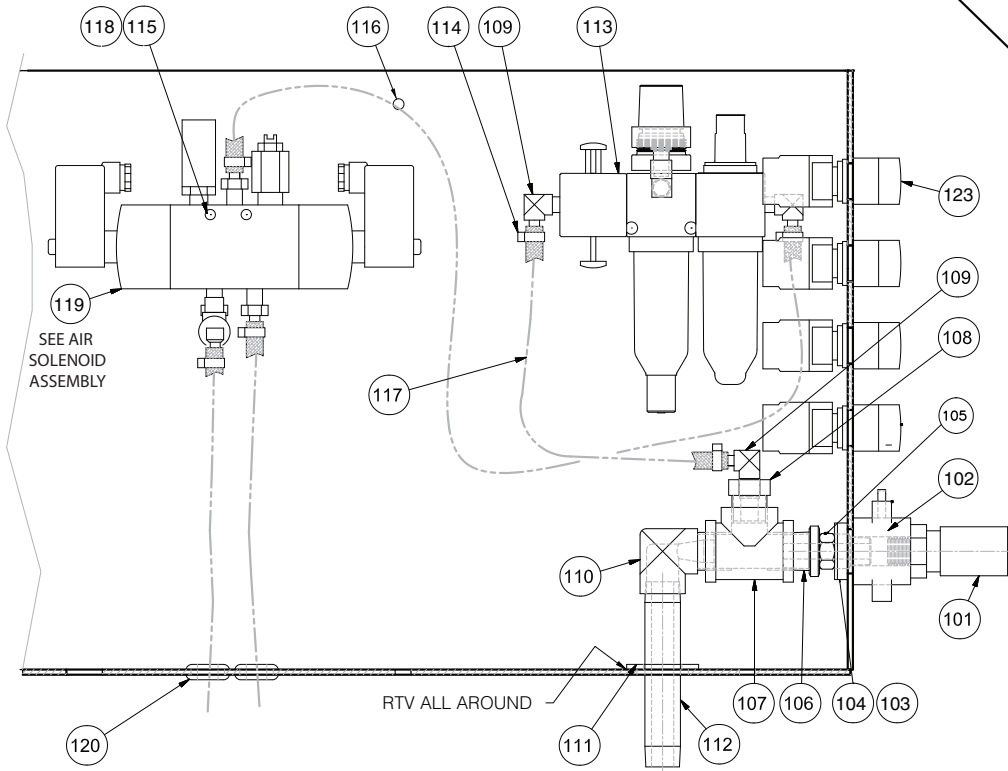

SECTION D-D

ITEM NO.	PART NO.	DESCRIPTION	QTY.
101	KE601603	QUICK CONNECT	1
102	KE601601	SLIDE VALVE	1
103	FA30512	SPACER WASHER	1
104	FA32500	TOOTH LOCK WASHER 7/8 DIA.	1
105	KE52697	NUT 1/2 NPS BRASS	1
106	KE601602	AIR FITTING	1
107	KE600814-1	TEE 1/2 NPT	1
108	F100351	BUSHING 1/2 MIP X 1/4 TIP	1
109	F105318	HOSE BARB 90 DEGREE ELBOW	3
110	KE600812-1	90 DEGREE STREET ELBOW 1/2 NPT	1
111	FA30090	WASHER 15/16 ID X 1 3/4 OD X 1/8 TH	
112	N0440B4.5	NIPPLE 1/2 NET X 4 1/2 LONG	
113	KE02369	FILTER-REGULATOR-LUBRICATOR ASSY	
114	F105220-1	GEAR CLAMP	4
115	FA21002	HEX NUT, 6-32, S.S.	4
116	KE532177	PNEUMATIC HOSE, 1/4 ID X 31 L	1
117	KE532176	PNEUMATIC HOSE, 1/4 ID X 12 1/2 L	1
118	FA32004	TOOTH LOCK WASHER, #6, ZINC PLATED	4
119	KE02292	AIR SOLENOID ASSEMBLY (SEE SOLENOID ASSEMBLY DRAWING)	1
120	KE50555-3	GROMMET	2
123	KE01812-1	SWITCH; ON/OFF/ON (MAINT/MAINT/MOM)	1

GEAR BOX ASSEMBLY

(Used after December 2006)

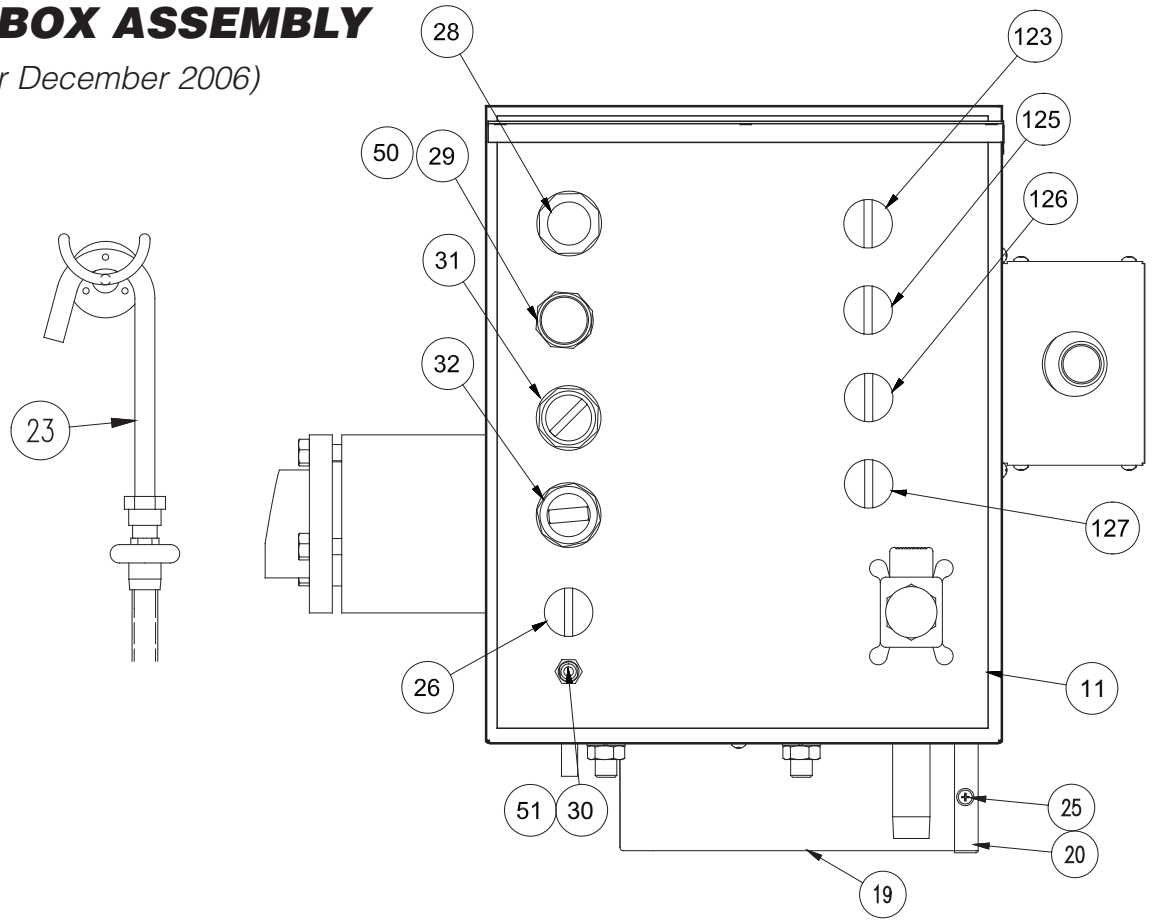

ITEM NO.	PART NO.	DESCRIPTION	QTY.
	KE000863-3	DIGITAL WATER METER	
11	KE95481-4	LABEL; GEARBOX	1
19	KE602793	MOTOR BOTTOM BOX	1
20	KE602795	SIDE COVER MOTOR	1
23	KE55231-1	Y SINGLE WALL POT FILLER	1
25	FA11145	MACHINE SCREW 10-32 X 3/8, S.S.	4
26	KE003209-11	SWITCH, ON/OFF/ON (MOM/TILT/MOM)	1
28*	KE54531	BUTTON, AGITATOR STOP	1
29*	KE54530	BUTTON, AGITATOR START	1
	KE603106	LED LAMP	1
30	KE50579-1	CIRCUIT BREAKER, RESET	1
31*	KE54529	SWITCH, AGITATOR POWER	1
32*	KE54532	SWITCH, SPEED CONTROL	1
50	KE603106	LED LAMP	1
51	KE50580	WATER RESISTANT BOOT	1
123	KE01812-1	SWITCH; ON/OFF/ON (MAINT/MAINT/MOM)	1
125	KE01810	SWITCH; ON/OFF (SPRING RETURN)	1
126	KE003209-6	SWITCH; ON/ON (MAINTAINED)	1
127	KE003209-3	SWITCH; ON/OFF/ON (LEFT & RIGHT MOM)	1
132	KE52936-3	FUSE, 1 AMP (NOT SHOWN)	1
133	KE51139	FUSE HOLDER (NOT SHOWN)	1
134	KE50343-6	COMPONENT PLATE (NOT SHOWN)	1
135	KE50343-1	SWITCH ASSEMBLY, ON/OFF MAINTAINED (NOT SHOWN)	1
136	KE50753-10	RELAY (NOT SHOWN)	2

* SWITCHES MAY BE LOCATED ON REMOTE CONTROL PANEL.

CONTROL BOX ASSEMBLY-

WATER METER & CHART RECORDER (Used prior to June 2007)

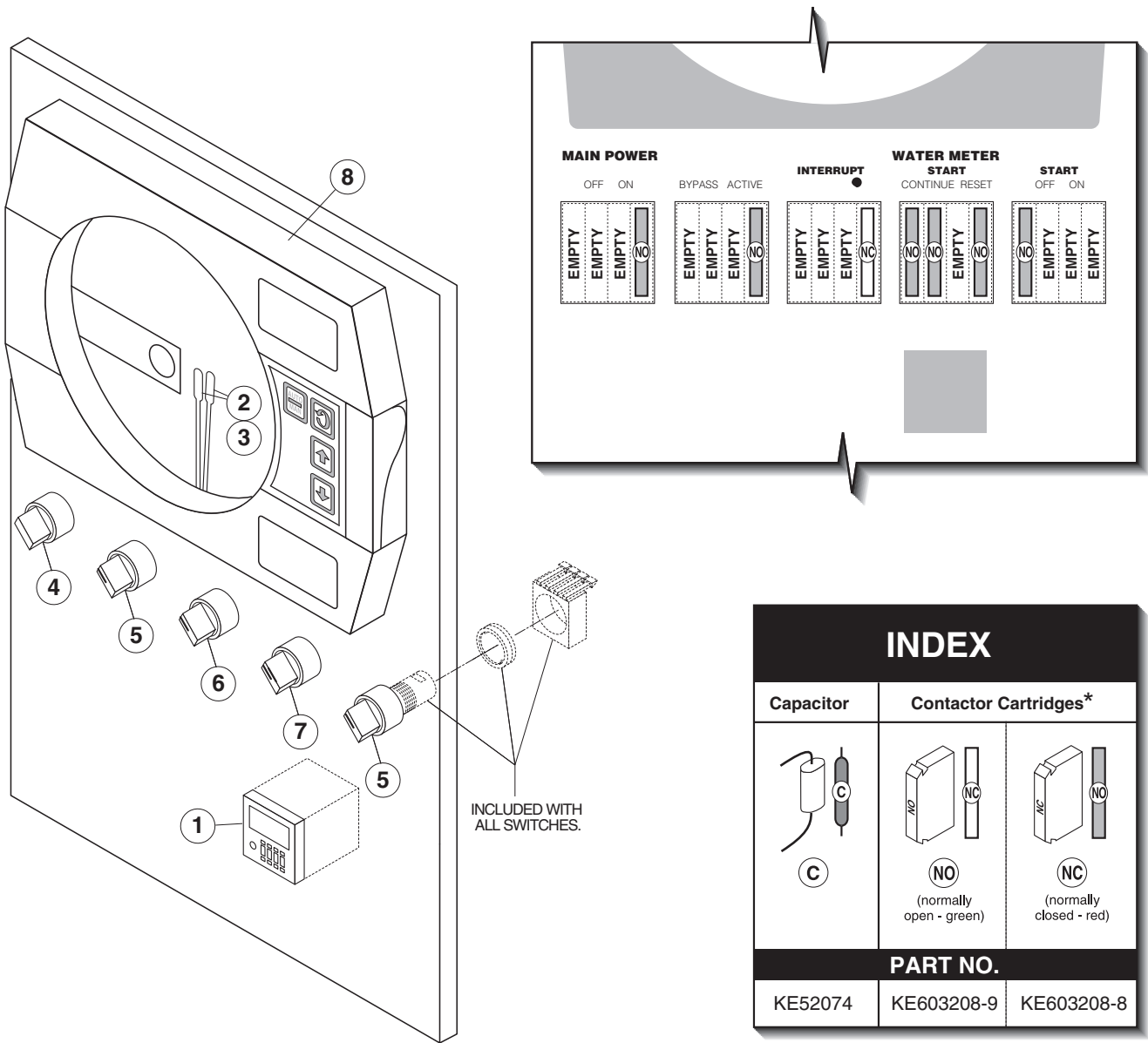

INDEX		
Capacitor	Contactor Cartridges*	
(C)	(NO) (normally open - green)	(NC) (normally closed - red)
PART NO.		
KE52074	KE603208-9	KE603208-8

* **NOTES:** For units built prior to December 2006, the complete switch assembly must be ordered.

ITEM NO.	PART NO.	DESCRIPTION	QTY.
1.	KE53257	Digital Counter	1
2.	SE50354	Pen Tip, red (pkg. of 5)	1
3.	SE50354	Pen Tip, green (pkg. of 5)	1
4.	KE003209-1	Switch Assembly, On/Off - Maintained	1
5.	KE003209-1	Switch Assembly, On/Off - Maintained	2
6.	KE003209-6	Momentary Spring Return Switch Assembly	1
7.	KE003209-7	Momentary Spring Return Switch Assembly	2
8.	KE53136-1	Chart Recorder	1

CONTROL BOX - ELECTRICAL

For front panel control switches see -
GEARBOX ASSEMBLY & CONTROL BOX ASSEMBLY

NOTE: Dual control panel shown.
Single panel uses 1/2 the parts.

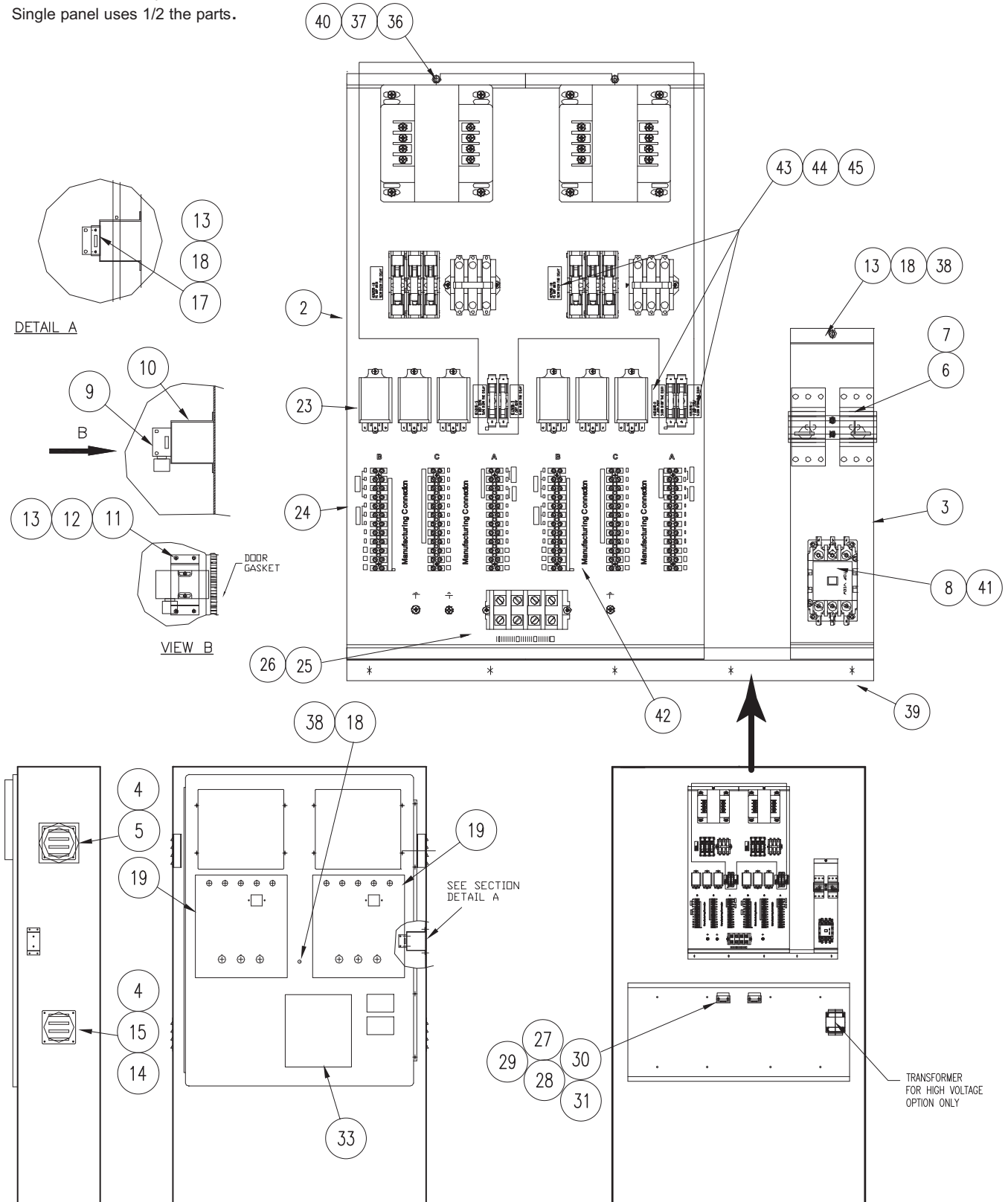

CONTROL BOX - ELECTRICAL

ITEM ON.	PART NO.	DESCRIPTION	QTY.
			Single / Duo
2	KE55284-1	COMPONENT MNTG PLATE, DUAL PANEL	- / 1
	KE55284-2	COMPONENT MNTG PLATE, SINGLE PANEL	1 / -
3	KE55286-2	MOUNTING BRACKET, INCOMING	1 / 1
4	KE54860	FAN	2 / 2
5	KE55283	VENT COVER PLATE	4 / 4
6	KE55288-2	MOUNTING RAIL	1 / 1
7	KE55298	MOTOR PROTECTOR SWITCH	1 / 2
		CONTACTOR FOR 208-240 VAC SUPPLY	
8	KE50750-4	CONTACTOR, 230 VAC, 50 AMP	- / 1
	KE50750-2	CONTACTOR, 230 VAC, 30 AMP	1 / -
		CONTACTOR FOR 460 VAC SUPPLY	
41	KE50750-7	CONTACTOR, 120 VAC, 50 AMP	- / 1
	KE50750-1	CONTACTOR, 120 VAC, 30 AMP	1 / -
9	KE55297	SAFETY INTERLOCK SWITCH	1 / 1
10	KE55285	MOUNTING BRACKET, DOOR INTERLOCK SW	1 / 1
11	FA40000-15	WELD STUD, #10-32 X 1/2, S.S.	4 / 4
12	FA21007	HEX NUT, #10-32, S.S.	4 / 4
13	FA32006	S.S. TOOTH LOCK WASHER, #10	7 / 7
14	FA11091	S.S. #8-32 X 3/8 SCREW	16 / 16
15	FA21004	S.S. NUT #8-32	16 / 16
17	FA40000-14	S.S. #10-24 X 3/4 WELD STUD	2 / 2
18	FA21006	S.S. HEX NUT #10-24	4 / 4
19	KE55271	LABEL, REMOTE CONTROL PANEL	1 / 2
23	KE50753-10	RELAY, 120 V (HOT/COLD WATER, BYPASS)	3 / 6
24	KE603615	TERMINAL BLOCK	3 / 6
25	KE50377	TERMINAL BLOCK	4 / 4
26	KE50376	TERMINAL BLOCK END	1 / 1
27	KE50374	TERMINAL BLOCK MOUNTING BRACKET	1 / 2
28	SK50055-1	TERMINAL BLOCK	7 / 14
29	SK50054-1	TERMINAL BLOCK END	2 / 4
30	KE54761-2	TERMINAL BLOCK MOUNTING RAIL	1 / 2
31	SK50054-2	TERMINAL BLOCK END	2 / 4
32	KE54761	TERMINAL BLOCK MOUNTING RAIL	1 / 2
33	KE90425-1	WIRING DIAG, DUAL REM. PANEL, 200/240V	- / 1
	KE90425-2	WIRING DIAG, SINGLE REM. PNL, 200/240V	1 / -
	KE90425-4	WIRING DIAG, DUAL REM. PANEL, 460/480V	- / 1
	KE90425-5	WIRING DIAG, SINGLE REM. PNL, 460/480V	1 / -
36	FA40000-2	SS 1/4-20 x 1/2 LG. WELD STUD	1 / 2
37	FA21008	HEX NUT, 1/4-20 SS	1 / 2
38	FA40000-1	SS 10-24 x 1/2 LG. WELD STUD	2 / 2
39	KE53450	JUGGLED STRIP (23 1/2 LG.)	- / 1
	KE53450-1	JUGGLED STRIP (CUT TO SUIT AT ASSY)	1 / -
40	FA31029	SS SPLIT LOCKWASHER 1/40	1 / 2
42	KE603617	LABEL	1 / -
	KE603635	LABEL (DUAL)	- / 1
43	KE52936-3	FUSE	1 / 2
44	KE52936-5	FUSE	1 / 2
45	KE52936-18	FUSE	1 / 2

WATER METER ASSEMBLY

(Used prior to July 2004)

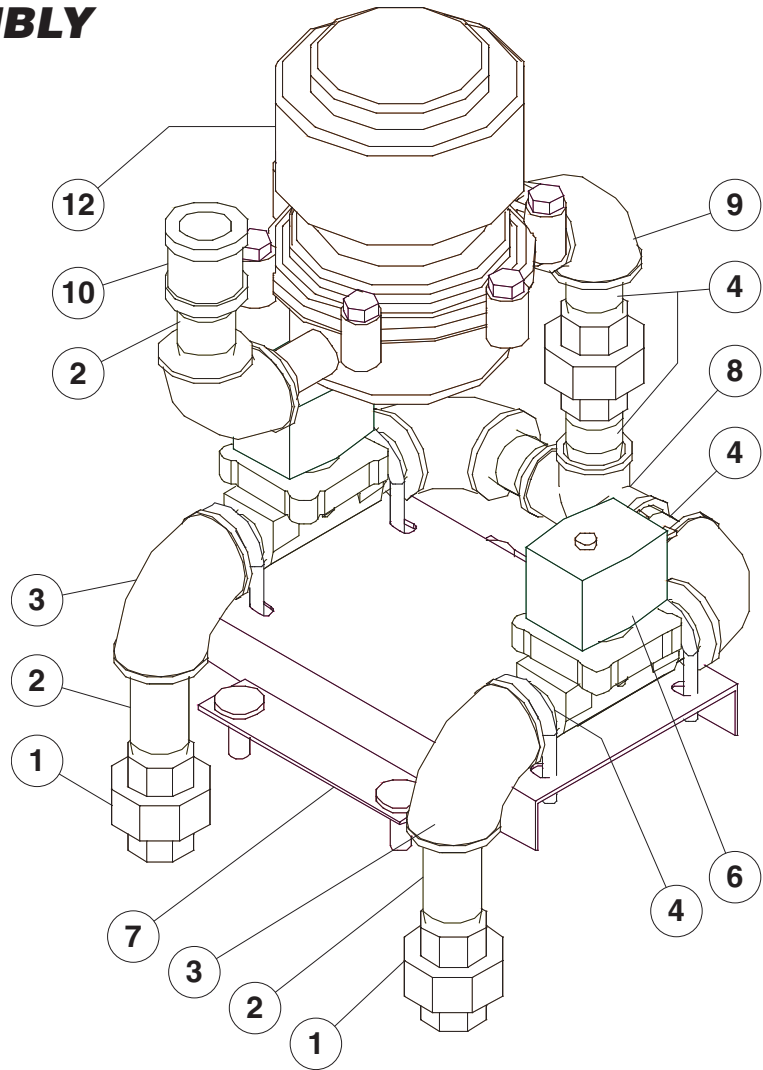

ITEM NO.	PART NO.	DESCRIPTION	QTY.
1.	FI00096	3/4 BRASS UNION	.3
2.	F100629-2	3/4 NPT X 2 112 BRASS NIPPLE	.3
3.	FI00063	3/4 NPT BRASS ELBOW	.4
4.	F100629-36	3/4 NPT CLOSE BRASS NIPPLE	.8
5.	KE55228	U-BOLT, 1/4-20	.4
6.	KE54834-4	SOLENOID VALVE	.2
7.	KE02290	MOUNTING PLATE ASSY, HOT COLD WM	.1
8.	R00179	3/4 NPT BRASS FEMALE TEE	.1
9.	FI00365	3/4 X 1 REDUCING BRASS ELBOW	.2
10.	FI00267	3/4 NPT BRASS COUPLING	.1
11.	FA21008	S.S. NUT 1/4-20	.8
12.	KE54336	GALLON METER	.1
	KE54336-1	QUART METER	.1
	KE52002-1	LITER METER	.1

WATER METER ASSEMBLY

(Used after July 2004)

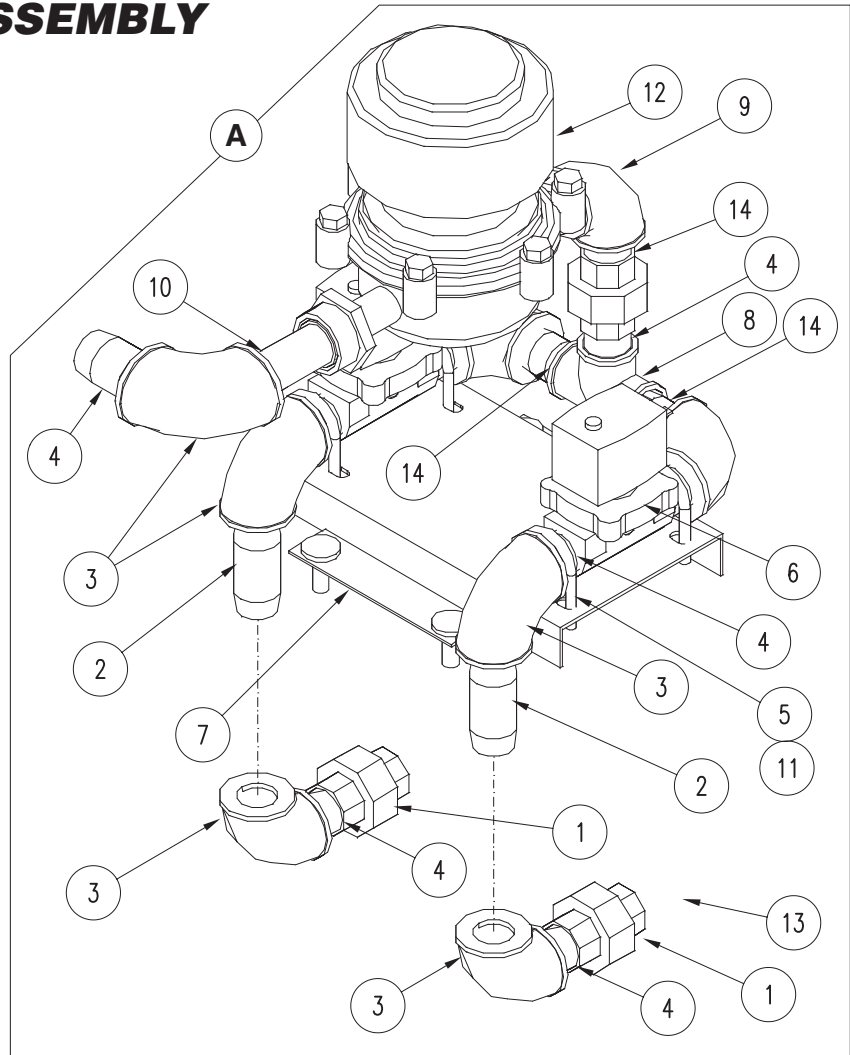

ITEM ON.	PART NO.	DESCRIPTION	QTY.
A	KE02289-1	COMPLETE ASSEMBLY; GALLON METER, HAMKGL-T	
	KE02289-2	COMPLETE ASSEMBLY; LITRE METER, HAMKGL-T	
	KE02289-3	COMPLETE ASSEMBLY; GALLON METER, HAMKGL	
	KE02289-4	COMPLETE ASSEMBLY; LITRE METER, HAMKGL	
1	FI00096	3/4 BRASS UNION	.3
2	FI00629-2	3/4 NPT X 2 1/2 BRASS NIPPLE	.2
3	FI00063	3/4 NPT BRASS ELBOW	.7/5
4	FI00629-36	3/4 NPT CLOSE BRASS NIPPLE	.10/6
5	FA95092-2	U-BOLT, 1/4-20	.4
6	KE54834-4	SOLENOID VALVE	.2
7	KE02290	MOUNTING PLATE ASSY, HOT COLD WM	.1
8	FI00179	3/4 NPT BRASS FEMALE TEE	.1
9	FI00365	3/4 X 1 REDUCING BRASS ELBOW	.1
10	FI05153	ADAPTOR NIPPLE & GASKET	.1
11	FA21008	S.S. NUT 1/4-20	.8
12	KE54336	GALLON METER, HOT WATER	
	KE52002-1	LITRE METER, HOT WATER	
13	KE51250-2	3/4 BRASS CHECK VALVE	.2
14	FI00629-1	3/4 NPT X 2 BRASS NIPLE	.3

COMPONENT ASSEMBLY

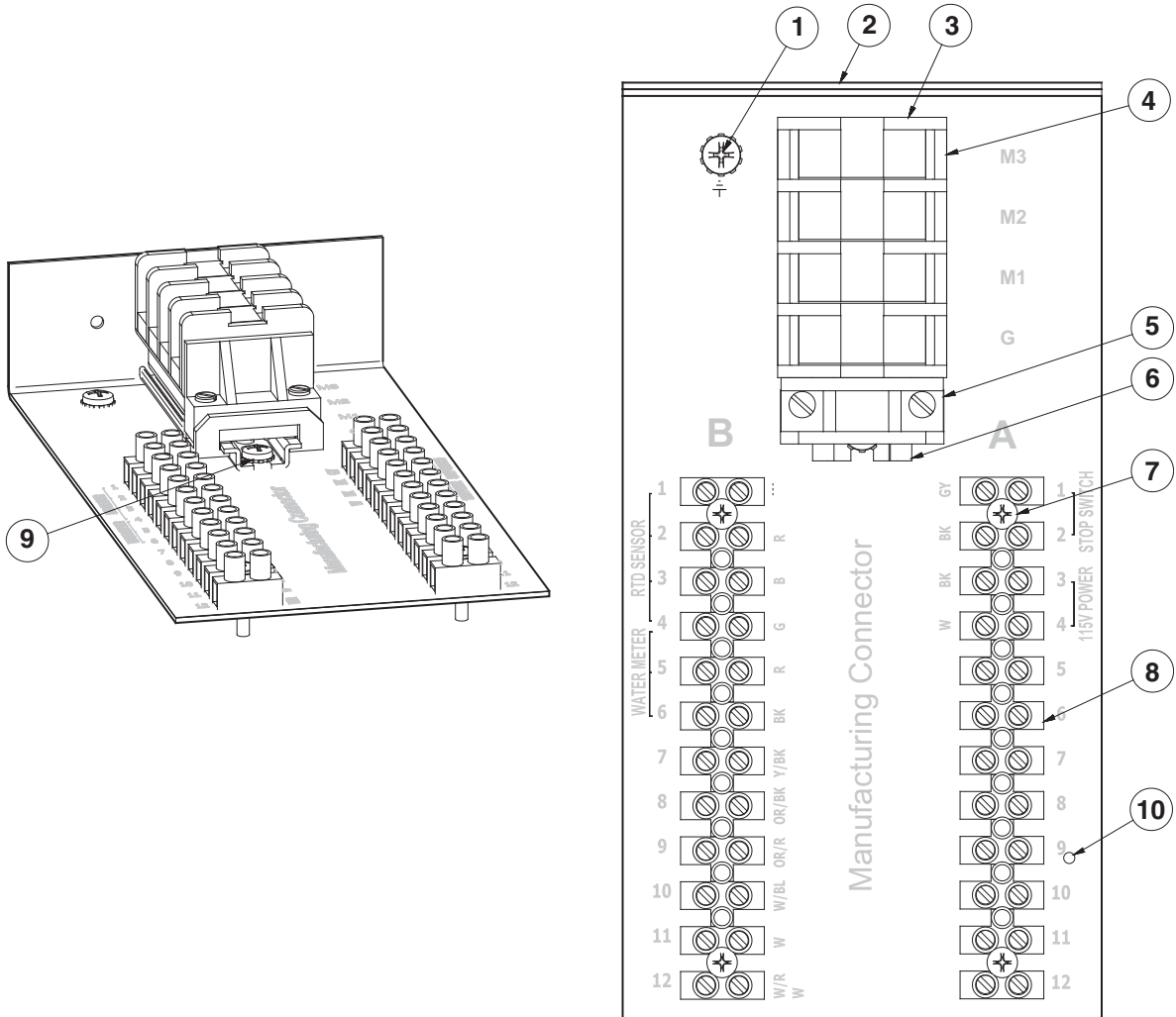

ITEM NO.	PART NO.	DESCRIPTION	QTY.
1.	FA11525-1	PHIL SCREW #10-32X3/8	1
2.	KE603401	COMPONANT BRACKET	1
3.	SK50054-1	TERMINAL BLOCK END BARRIER	1
4.	SK50055-1	TERMINAL BLOCK	4
5.	SK50054-2	TERMINAL BLOCK END BARRIER	1
6.	KE54761R	TERMINAL BLOCK MOUNTING RAIL X 3 1/4	1
7.	FA15018-6	PHIL SCREW #6-32X3/4	4
8.	KE603615	TERMINAL BLOCK	2
9.	FA15018-3	PHIL SCREW #8-32X1/4	2
10.	KE603616	LABEL	1

MAINTENANCE

INSPECTION AND MAINTENANCE CHECKLIST

Cleveland Range equipment requires little preventative maintenance. We do however provide the following chart as a guide line for inspection and maintenance to keep your unit functioning at 100%.

MONTHLY INSPECTION

- Inspect all switches for damage. Replace rubber boots or switches as required.
- Check that the automatic dump valve works fully and smoothly and no air leaks are evident.
- Check that the 3 way regulator shuts off the incoming air and completely vacates the air from the air hose to the metering filling station.
- Tilt kettle and check for smooth operation in both directions.
- Inspect gear and worm assembly in gear box for play - tighten Allen screws if required.
- Inspect gasket material on covers for integrity.
- Check spring assist covers for tightness to handle and insure spring is holding cover up - adjust if required. Refer to HINGE ADJUSTMENT INSTRUCTIONS.
- When kettle is cold check that pressure gauge needle is in the green zone indicating a vacuum in kettle - if venting is required refer to KETTLE VENTING PROCEDURE.
- Inspect mixer blades for cracks or other damage - replace as required. Refer to NEW SCRAPER BLADE INSTALLATION PROCEDURE.
- Check quad ring and replace if required. Refer to QUAD RING REPLACEMENT PROCEDURE.
- Inspect oiler in gear box and fill with oil if required. Refer to OILER FILLING PROCEDURE.
- Inspect air filter cartridge and replace if required. Refer to AIR FILTER REPLACEMENT PROCEDURE.

SIX MONTH MAINTENANCE

- Grease trunnion housings in gear box and on outboard bearings.
- Test pressure relief valve. Refer to PRESSURE RELIEF VALVE TESTING PROCEDURE.

OPERATING SEQUENCE - HEATING

STEP	ACTION	RESULT 1	RESULT 2
1.	Close main circuit breaker.	120 volts is supplied by primary contactor to kettle On/Off switch and tilt relay contacts. Power supplied to tilt assembly.	
2.	On/Off switch on kettle switched to ON.	120/16 volt transformer supplies power to control boxes.	Amber LED is illuminated. (Used prior to July 2004)
3.	Control box.	A/ Requires grounded probe to function (pin #5). B/ More that 6 volts at pin #2. Control box energizes 12 volt DC relay (pin #6).	a/ Green LED illuminates. b/ 12 VDC relay contacts close.
4.	12 VDC relay contacts close.	A/ Blower energizes. B/ 120/25 volt transformer energizes. C/ 120 volt supplied to ignition module.	a/ Air switch contacts close. a/ 25 volts supplied to ignition module.
5.	Ignition module.	Supplies 120 volts to ignition.	Within 20 seconds ignitor glows red.
6.	120 volts turned off to ignitor.	A/ Gas valve is energized. B/ Ignitor becomes sensor.	a/ Burner ignites. a/ If temperature drops in chamber gas valve is de-energized within five seconds. b/ Ignitor will try twice more to light before locking out.
7.	Temperature reached.	A/ Less than 6 volts at pin #2. Control box de-energizes 12 volt DC relay (pin #6)	a/ Green LED turns off. b/ 12 VDC relay contacts open. c/ Blower turns off. d/ 25 volt transformer de-energizes.

QUICK CHECKS: Potentiometer - Range 0 - 50K, Safety Thermostat - Normally Closed, Thermistor - Range 0 - 100K, Water Level Probe - Must be submerged in water for burners to work

OPERATING SEQUENCE - AGITATOR

1.	On/Off switch closed.	A/ Three phase contactor closes to supply power to variable speed drive.	a/ Indicator light is energized.
2.	Start button momentarily depressed.	A/ Power to agitator motor.	a/ Motor comes up to speed.
3.	Speed control turned up.	A/ Motor speed increases.	

OPERATING SEQUENCE - POWER TILT

1.	Turn and hold tilt switch in down position.	A/ Relay 2 is energized.	a/ Tilt motor is energized.
2.	Kettle tilts until limit switch is depressed.	A/ Power interrupted to down side of tilt switch.	a/ Relay de-energized. b/ Motor stops.
3.	Turn and hold tilt switch in up position.	A/ Relay 1 is energized.	a/ Tilt motor is energized.
4.	Kettle tilts until limit switch is depressed.	A/ Power interrupted to up side of tilt switch.	a/ Relay de-energized. b/ Motor stops.

KETTLE SAFETY INSPECTION CHECKLIST

Regular inspection and maintenance of units is essential to obtain trouble free and safe operation of equipment. Inspections must include testing of the pressure relief valve and checks of the operating system to insure that it has not been altered.

No safety features designed into the equipment should ever be tampered with. Tampering with or bypassing controls is a very dangerous practice and unfortunately we have seen several cases of this. Following is a short list of the most common and the most dangerous alterations performed on kettles.

SAFETY VALVE:

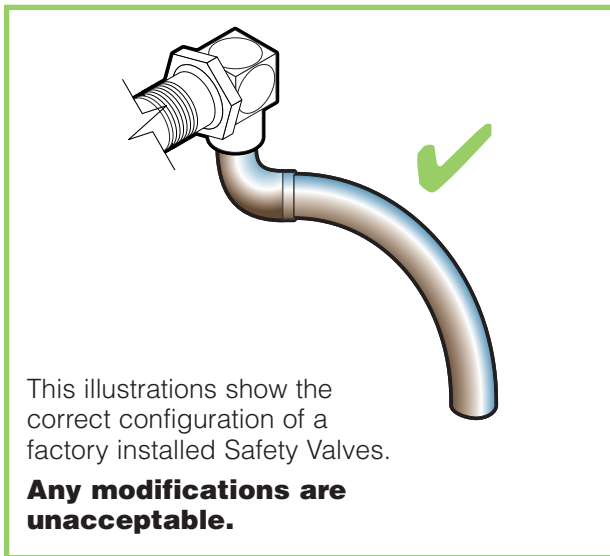

Incorrect Installations

- 1** Safety valve has plug threaded into the discharge opening preventing any steam from escaping.
- 2** Safety valve's tube diameter has been reduced.
- 3** Safety valve is sticking, frozen shut or plugged. To test, refer to PRESSURE RELIEF VALVE PERIODIC TESTING.
- 4** Safety valve is plumbed to a drain or water line creating back pressure and reducing flow.

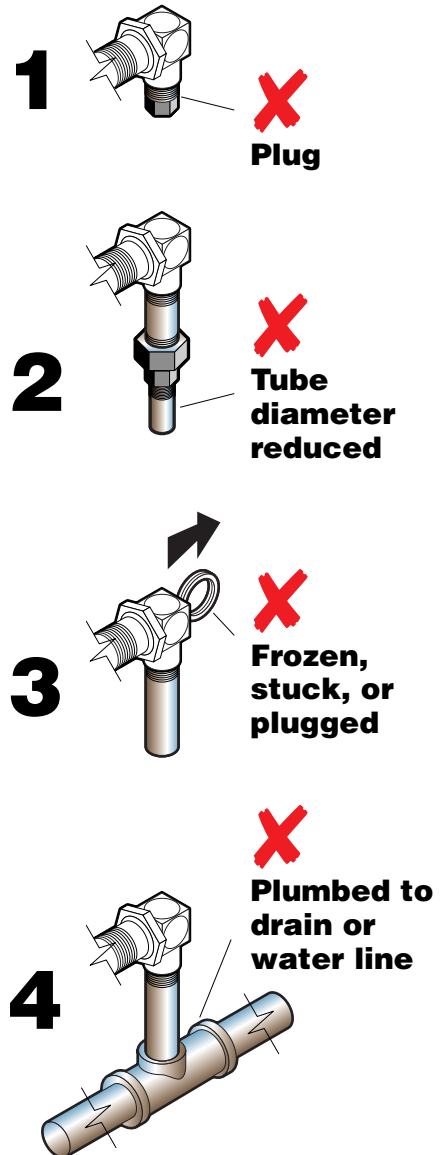

SAFETY THERMOSTAT:

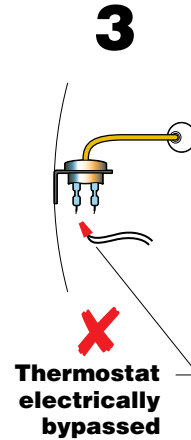
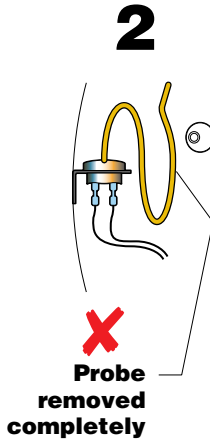
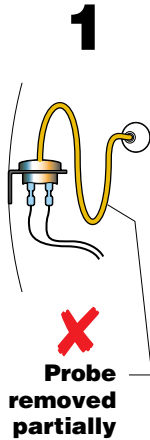
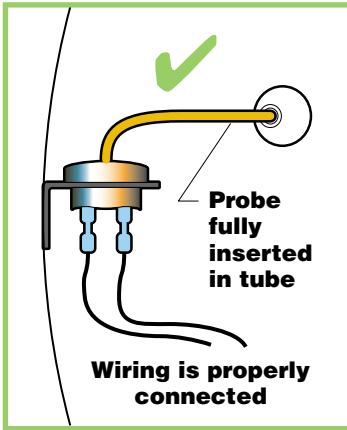

Incorrect Installations

- 1** Safety thermostat probe is not completely inserted into tubing.
- 2** Safety thermostat probe is removed from tubing.
- 3** Safety thermostat electrical connection is bypassed.

Low Water Level Probe:

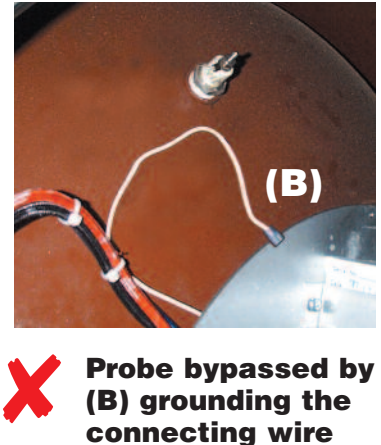
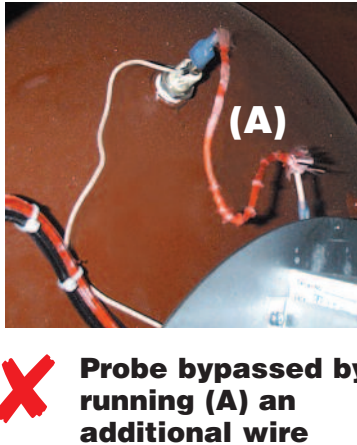
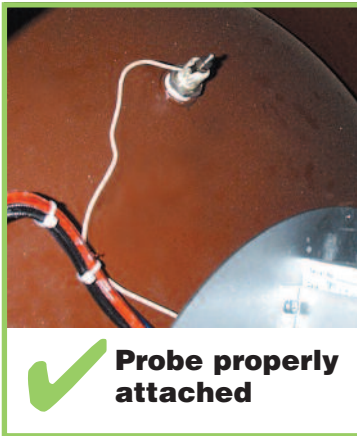

Operating Thermostat:

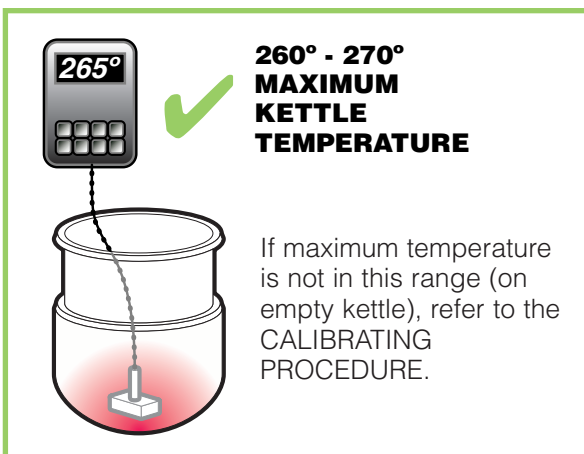

Air Switch:

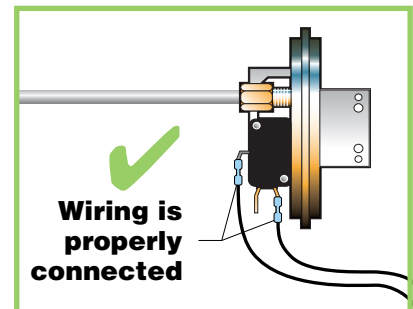

Incorrect Installation

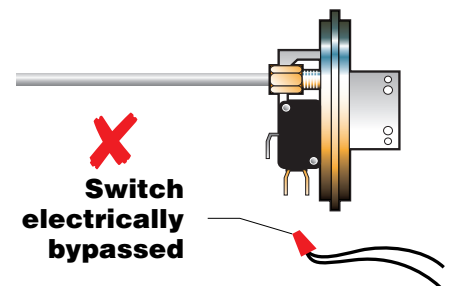

AIR FILTER REPLACEMENT PROCEDURE

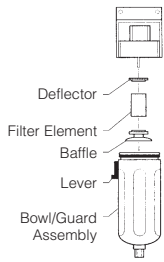

1. Disconnect air supply and bleed system.
2. Remove cover on console (see SIDE BOX - PNEUMATICS).
3. Check for filter location.
4. Push lever down and rotate bowl/guard assembly 1/8 turn.
5. Push down on bowl/guard assembly and remove.

6. Unscrew baffle and remove filter element, inspect and replace filter if required.
7. Replace filler cap and cover.

OIL FILLING PROCEDURE

1. Disconnect air supply and bleed system.
2. Remove cover on console.
3. Check for oiler location.
4. Inspect oil level in bowl.
5. Remove filler cap.
6. Add mineral oil as required.
7. Replace filler cap and console cover.

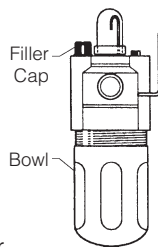

HINGE ADJUSTMENT INSTRUCTIONS

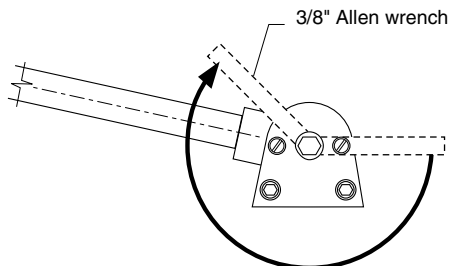

1. Insert 3/8" Allen wrench.
2. Turn clockwise to relieve tension on spring.
3. While tension is released remove one of the two slotted screws.
4. To prevent Allen wrench from springing back abruptly while the second slotted screw is removed, insert a pin (approximately 1/8") in the hole where the first slotted screw was removed from.
5. Remove second slotted screw.
6. While holding Allen wrench remove pin.
7. Turn Allen wrench clockwise to tighten or counter-clockwise to loosen tension to produce desired effect.
8. Re-insert pin in one of the two holes.
9. Tighten one slotted screw in the other hole (it may be necessary to turn Allen wrench slightly to align holes).
10. Remove pin and repeat step number 9 for other slotted screw.

NEW SCRAPER BLADE INSTALLATION PROCEDURE

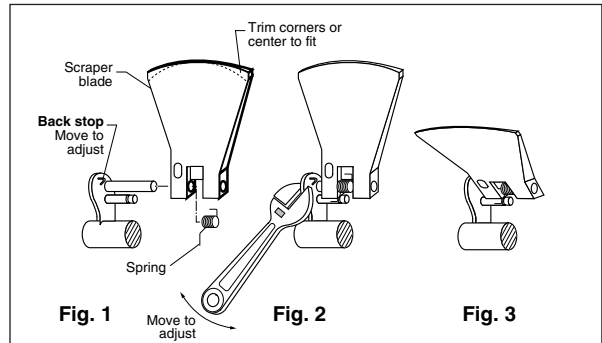

When installing a new scraper blade there may be some adjustments required to make it lay flat to follow the contour of the kettle. If the blade does not fit, you may have to grind either the two edges of the blades, or the center of the blade

Note: When there is too much or too little pressure on the scraper blade, bend the back stop down to decrease the pressure or bend it up to increase the pressure on the blade, when scraping the kettle surface (see Fig. 1)

Note: If only one corner of the scraper blade is touching the kettle surface, use a crescent wrench and slightly twist the scraper holder so the entire blade scrapes the kettle wall with even pressure

LUBRICATION PROCEDURE

Lubricate the following parts every three months to insure smooth operation and reduce wear.

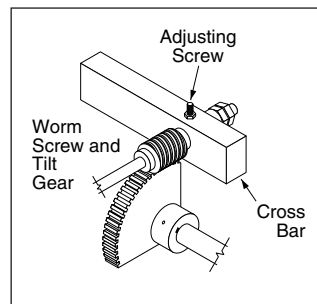

TRUNNION HOUSING, WORM SCREW AND TILT GEAR

These parts are accessed through the top cover of the console.

Apply grease to gear teeth. Check for

excessive play and adjust with adjusting screw located on top of cross bar.

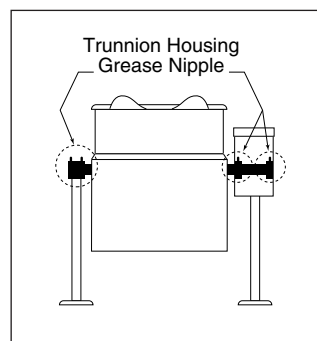

KETTLE TRUNNIONS

On the left hand side of the kettle there are two grease nipples on the top back portion of the trunnion housing. On the right hand side of the kettle you must remove the console cover to access the two grease nipples.

FLUSH PISTON VALVE

Replacing "O" rings

(Used prior to 2003.)

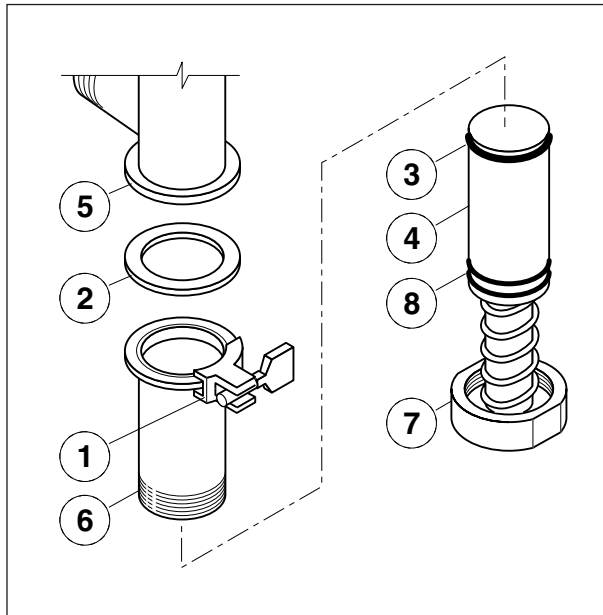

Automatic Dump Valve

1. Disassemble valve as per daily cleaning instructions.
2. Holding lower valve body (6), unscrew valve bottom (7).
3. Pull lower valve body out from cylinder body.
4. Replace "O" rings (8), as required.
5. Coat cylinder body and "O" rings with cooking oil or food-safe grease.
6. Reassemble.

(Used after June 2003.)

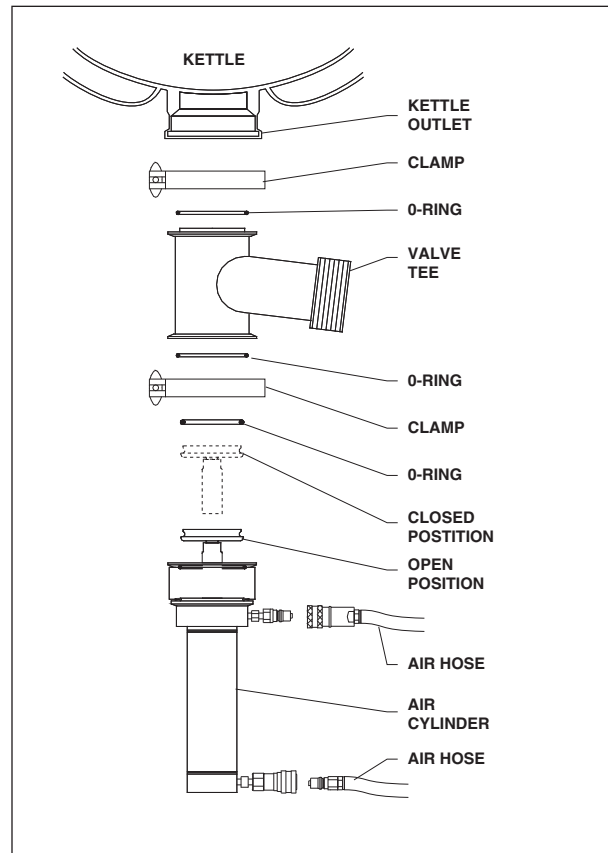

1. Open product valve.
2. Disconnect air hoses.
3. Remove air cylinder.
4. Remove valve tee.
5. Remove all O-rings, grease and reinstall new O-rings as required.
6. Reinstall tee to kettle outlet.
7. Reinstall air cylinder to bottom of tee.
8. Reconnect air hoses.
9. Close valve and check for alignment.

BUSHING REPLACEMENT PROCEDURE

1. Remove agitator as per cleaning instructions.
2. Remove bushing by turning 1/4 turn and pulling away from the kettle wall.
3. Lubricate metal surfaces with food safe grease.
4. Install new bushing by locating retaining pin and sliding bushing on.
5. Rotate to lock into position.
6. Reassemble agitator.

QUAD RING REPLACEMENT PROCEDURE

(Used prior to June 1999, after June 1999 see SEAL RETAINER PLATE REPLACEMENT PROCEDURE.)

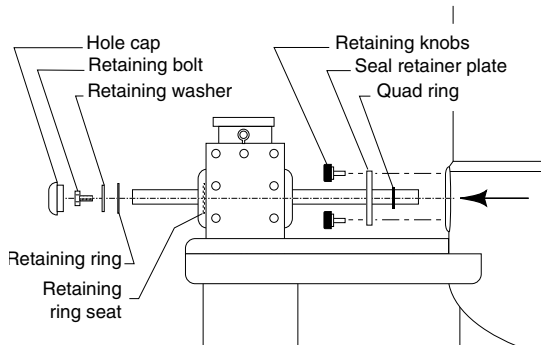

1. Remove agitator as per cleaning instructions.
2. Remove hole cap, retaining bolt and retaining washer.
3. Snap retaining ring out from seating inside motor.
4. Remove retaining knobs.
5. Slide seal retainer plate away from kettle.
6. Slide shaft away from kettle body to allow clearance for removing quad ring.
7. Remove quad ring.
8. Slide new quad ring back into original position, making sure it does not twist.
9. Apply light coat of food-safe grease.
10. Slide shaft back into kettle.
11. Slide retainer plate back toward kettle, replacing retaining knobs - tighten with hand pressure only.
12. Reassemble.

SEAL RETAINER PLATE REPLACEMENT PROCEDURE

(Used after June 1999.)

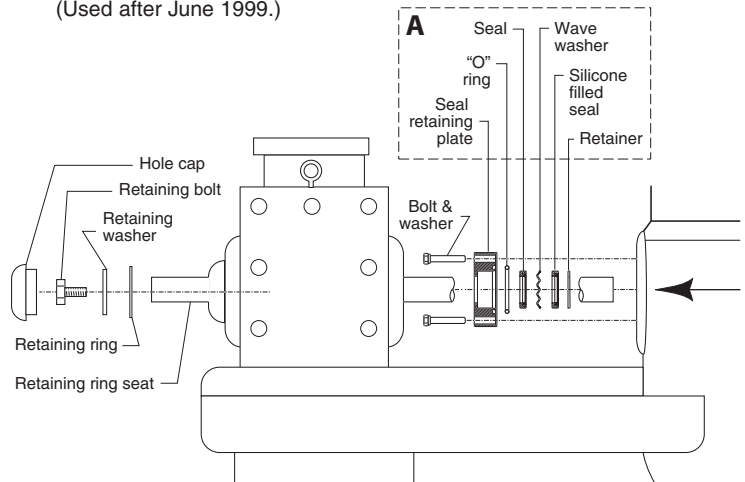

1. Remove agitator as per cleaning instructions.
2. Remove hole cap, retaining bolt and retaining washer.
3. Snap retaining ring out from seating inside motor.
4. Remove bolts and washers securing parts "A".
5. Slide parts "A" away from kettle.
6. Slide shaft away from kettle body to allow clearance for removing parts "A".
7. Remove parts "A".
8. Replace seal, wave washer and silicone filled seal.
9. Slide new part "A" back into original position, making sure it does not twist.
10. Slide shaft back into kettle.
11. Slide parts "A" back toward kettle, replacing bolts and washers.
12. Reassemble.

POWER TILT GEARMOTOR

CALIBRATING THE TORQUE LIMITER SLIP TORQUE

The device is factory calibrated to a slip torque which coincides with the nominal torque $Mn2$ [$n1= 1400$] for the gear unit in question.

If calibration is ever required follow these steps:

1. The calibration ring nut is screwed in until the disk springs are loaded to the point that they cannot be turned freely by hand.
2. A centre punch is used to make two corresponding reference marks at the same angular position on the ring nut and the protruding section of the output shaft. This reference position is the starting point from which all further turns of the ring nut are counted, and thus, the torque calibration is measured.
3. The ring nut is now screwed in by the fractions of a turn which correspond to the nominal torque $Mn2$ for the gear unit in question. The reference in this case is given by the diagram below, which is also to be used for any new settings required over time.

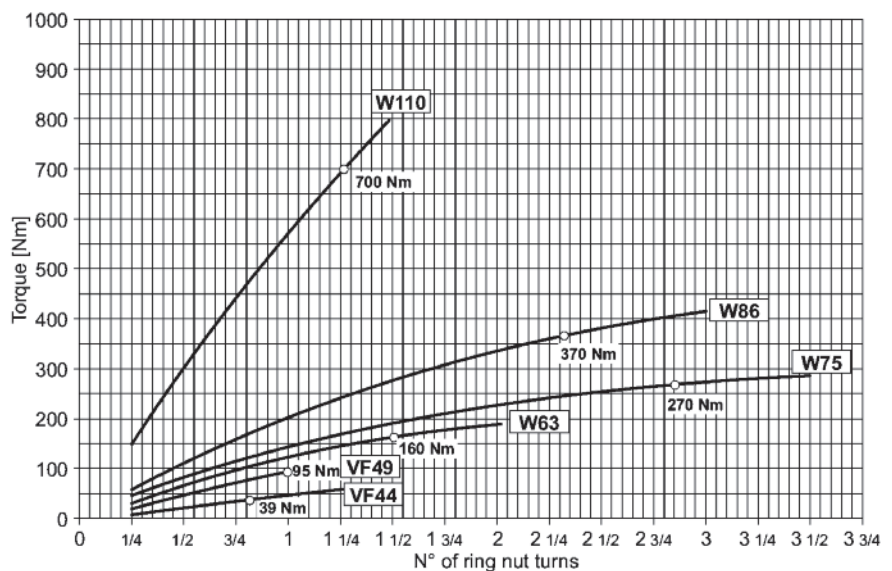

KETTLE VENTING INSTRUCTIONS

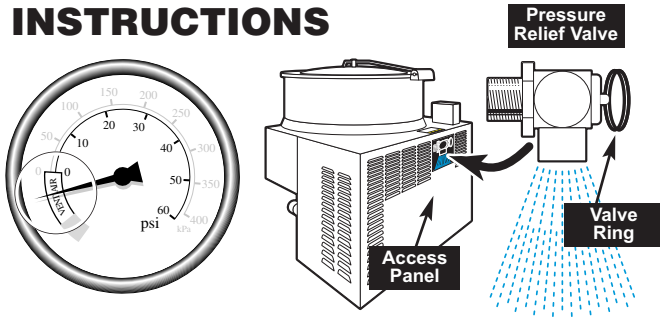

The following venting procedure should be followed when the Vacuum/Pressure Gauge needle is in the "VENT AIR" zone:

NOTE: Check for and eliminate leaks prior to venting (See REPAIRING LEAKS IN STEAM JACKETED KETTLE FITTINGS).

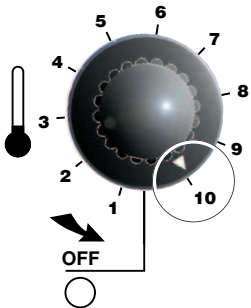
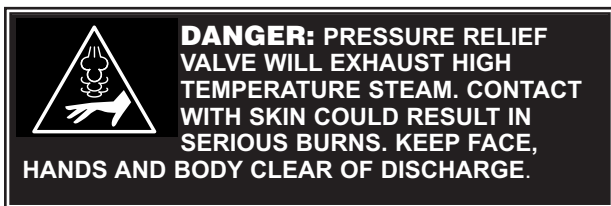

1. Remove Access Panel from back of main kettle console.
2. Turn kettle ON and set temperature control to **10**, heat the empty kettle until unit cycles off.
3. Vent kettle by pulling Valve Ring eight to fifteen times, holding valve open for two seconds each time.

NOTE: If unit cycles ON, stop venting and wait for kettle to cycle OFF before continuing.

4. Turn kettle OFF. Add cold water to kettle until its surface temperature is below 100°F. The pressure gauge needle should be in the green zone, indicating a vacuum in the kettle's jacket.

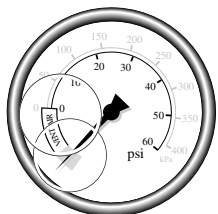
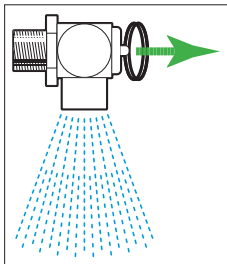

5. If needle is in the green zone then venting was successful. If not repeat procedure.

VACUUM LEAK TEST PROCEDURE

If the kettle will not hold vacuum, test for leaks at:

- A. Water Level Probe.
- B. Pressure Relief Valve/Pressure Gauge and connecting plumbing.
- C. Boiler Drain Cap.
- D. Sight Glass.

LEAK TEST PROCEDURE:

1. Heat kettle until unit cycles off.
2. Shut off power to the kettle at the fused disconnect switch.
3. Spread Bubble Type Leak Detector over suspected areas and watch closely for bubbles.
4. Repair areas as required.

REPAIRING LEAKS IN STEAM JACKETED KETTLE FITTINGS

If unit will not hold a vacuum the most likely cause is a leak at one of the fittings.

Often, the easiest way to eliminate a leak is reseal the suspect areas.

1. Water Level Probe
 - Remove, clean threads, apply teflon thread sealant and reinstall.
2. Pressure Relief Valve
 - A/ Inspect for signs of leaks. Replace if required.
 - B/ Remove, clean threads, apply teflon thread sealant and reinstall.
3. Pressure Gauge
 - A/ Inspect face of gauge. If it contains moisture on the inside of face replace.
 - B/ Check tightness of plumbing connection to pressure Gauge.
3. Sight Glass
 - A/ Check tightness of sight glass.
 - B/ Replace "O" ring if required.

RESERVOIR FILL PROCEDURES

WARNING: IMPROPER REFILLING OF KETTLE JACKET WILL RESULT IN IRREVERSIBLE DAMAGE TO UNIT.

The kettle's water level must be maintained at the proper level. Under normal operating conditions, the sealed water reservoir should never require the addition of water.

If the red "low water" light comes on during use (while the kettle is in an upright position), the water level has reached a critically low level. The low water protection control has automatically shut off the gas burner. The following procedure must be completed before further use:

DANGER: PRESSURE RELIEF VALVE WILL EXHAUST HIGH TEMPERATURE STEAM. CONTACT WITH SKIN COULD RESULT IN SERIOUS BURNS. KEEP FACE, HANDS AND BODY CLEAR OF DISCHARGE.

DANGER: WORKING ON MACHINES WITH POWER COULD RESULT IN SEVERE ELECTRICAL SHOCK.

NOTE: Have a qualified service technician repair the leakage problem and add water to the unit. Ensure that the red "low water" light is on when the kettle is upright. On tilting kettles, it is normal for the red light to come on when the kettle is in a tilted position.

CAUTION: Only distilled water should be used when adding water to a partially filled water reservoir (If unit is completely empty see KETTLE JACKET FILLING & DRAINING PROCEDURES). Local tap water conditions may cause kettle damage which is not covered under warranty. Rust inhibitor is purchased locally. Read directions and do not exceed manufacturer's recommendation (excessive rust inhibitor can also cause solidification).

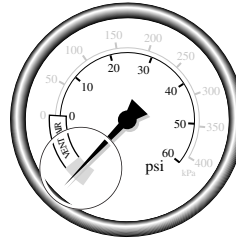

1. Ensure kettle is at room temperature and pressure gauge showing zero or less pressure.
2. Shut off power to the kettle at the fused disconnect switch.

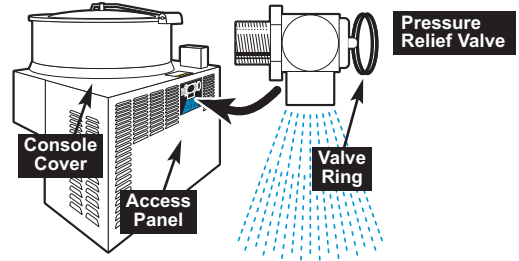

3. Remove Access Panel from back of main kettle console.

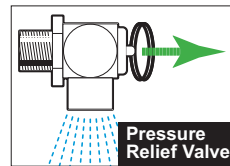

4. Pull Pressure Relief Valve Ring open to insure vessel is not pressurized.
5. Remove main kettle Console Cover.

Important- Pull ring on Pressure Relief Valve prior to removal to insure vessel is not pressurized.

6. Remove 1/4" copper tubing and reducer bushing.
7. Add distilled water using a funnel if necessary. Fill the unit to the high level mark on the Sight Glass.



8. Apply a thread sealant (i.e. Teflon tape) to the reducer bushing threads and replace.
9. Replace main kettle Console Cover and Access Panel.

10. Restore power to unit at the fused disconnect switch.

11. The kettle must now be vented. (Refer to the KETTLE VENTING INSTRUCTIONS).

PRESSURE RELIEF VALVE PERIODIC TESTING

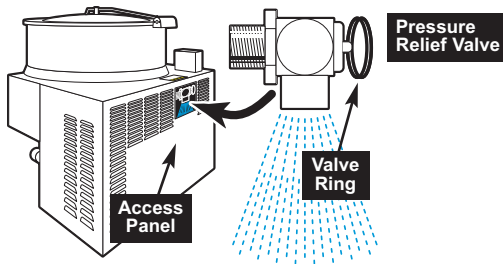

Most insurance agencies require periodic testing of pressure relief valves used on pressure vessels. This procedure will allow you to safely and quickly test your kettle's pressure relief valve. We recommend this test be performed twice a year.

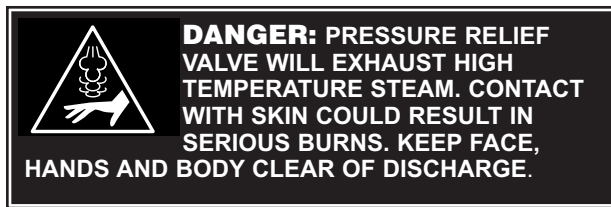

NOTE: The following instruction is intended for use by qualified service personnel.

WARNING: Kettle surface will be hot and steam will be released during testing. Take necessary precautions including the use of gloves and eye protection to prevent personal injury.

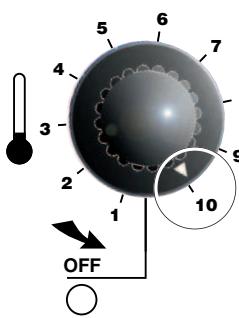

1. With the kettle empty, turn unit ON and set temperature control to **10**. Allow the kettle to heat until the unit cycles off.
2. Switch unit OFF and disconnect main power at fused disconnect switch.
3. Remove Access Panel at back of main kettle console.
4. Pull Pressure Relief Valve Ring open for a maximum of one second. Repeat test three to four times. Each time the mechanism should move freely and be accompanied by a rapid escape of steam.

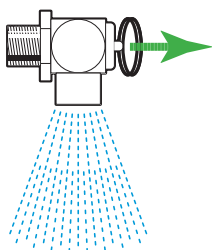

NOTES:

If valve appears to be sticking replace pressure relief valve.

If foreign material is discharged then drain kettle and replace pressure relief valve.

See service bulletin (KETTLE JACKET FILLING AND DRAINING PROCEDURES) for full instructions on the correct method for draining and refilling kettle jacket.

WARNING: Improper refilling of kettle jacket will result in irreversible damage to unit.

5. Replace Access Panel.

6. Reconnect main power at fused disconnect switch..

CALIBRATING PROCEDURE

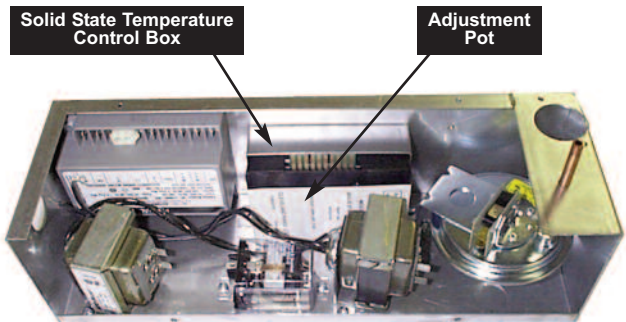

1. Insure the unit has a vacuum before you begin calibrating procedures. If unit requires venting refer to KETTLE VENTING INSTRUCTIONS.

2. Turn kettle ON and set temperature control to **10**.

3. Allow the unit to cycle twice.

4. Check temperature of the inner kettle surface with a digital surface thermometer.

5. Temperature should be between 260°F and 265°F.

6. Using a screw driver adjust temperature by turning the potentiometer on the Solid State Temperature Control Box. Turn very little. Turn clockwise to INCREASES and counter-clockwise to DECREASE temperature.

7. Allow the unit to cycle twice.

8. Check temperature of the inner kettle surface with a digital surface thermometer.

9. Repeat steps 4. through 8. until unit is calibrated.

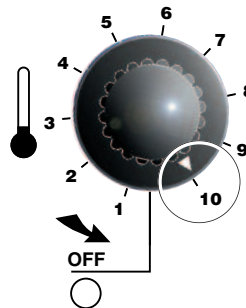

KETTLE JACKET FILLING & DRAINING PROCEDURES

Under normal circumstances the kettle does not require the draining of all fluid. If the red "low water" light is on, follow the RESERVOIR FILL PROCEDURES in this manual.

If unit must be drained follow the procedures described on the following pages.

WARNING: IMPROPER REFILLING OF KETTLE JACKET WILL RESULT IN IRREVERSIBLE DAMAGE TO UNIT.

Use only a mixture of water and rust inhibitor to refill kettle jacket (see instructions below).

Contact your local water treatment company and purchase rust inhibitor with the specifications described below.

Recommended Corrosion Inhibitors for Closed Systems

DESCRIPTION

Recommended for our units is a blend of SODIUM NITRITE and BORAX for corrosion inhibition of ferrous metals and axoles for copper and copper alloy corrosion protection. Product should be formulated for hot or cold closed recirculating water systems.

Source the chemicals stated above from your local water treatment company. Mix only with water and follow manufactures recommended mixing rate.

DISPOSAL OF INHIBITOR

Do not dispose of chemicals in any system which may discharge into water supplies used for drinking or washing or that could accidentally discharge into such systems, or into stream accessible to animals.

Follow all Federal, State and local codes when disposing of product.

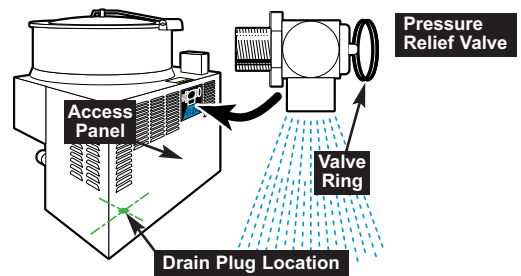
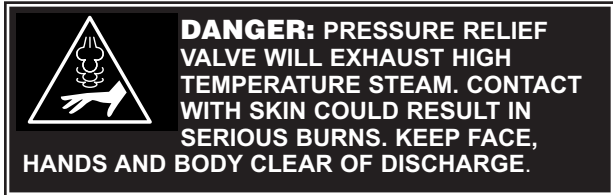

1. Remove Access Panel at back of main kettle console.
2. Pull pressure relief valve chain to ensure there is no pressure within the kettle jacket.
3. Remove 1/4" copper tubing and reducer bushing.
4. Remove drain plug cap (located underneath the kettle on the right rear). Allow kettle jacket to drain.
5. Replace filler plug and add water until it shows on sight glass. Remove Drain Plug cap and allow water to drain. Repeat until water drains clear.

Refilling Unit (see RESERVOIR FILL PROCEDURES).



HA DRIVE SHAFT REPLACEMENT PROCEDURE

Note: Disconnect external power supply and shut off gas to unit prior to servicing.



1. Remove mixer arm leaving flat surface on drive shaft facing upwards.



2. Remove shaft end cap.

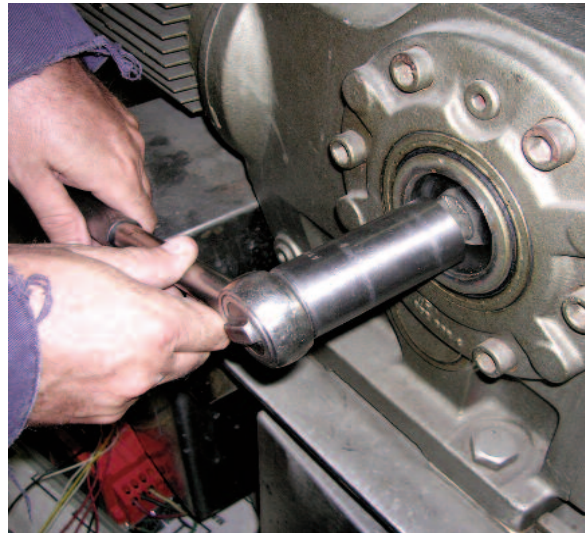

3. Remove shaft retaining bolt.



4. Remove shaft retaining ring.

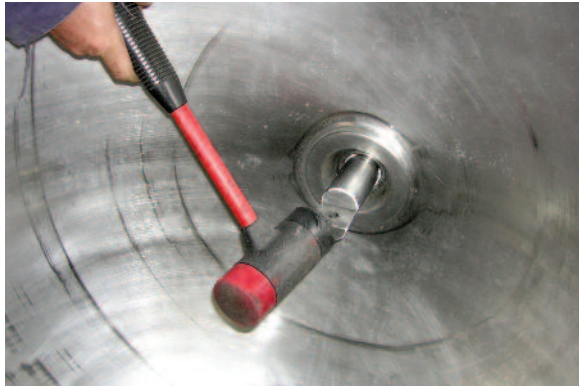

5. Gently hammer out shaft and remove.

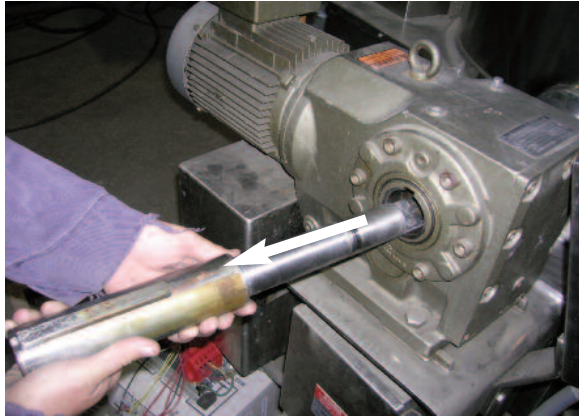

6. Clean seal.



7. Grease seal with food grade grease.

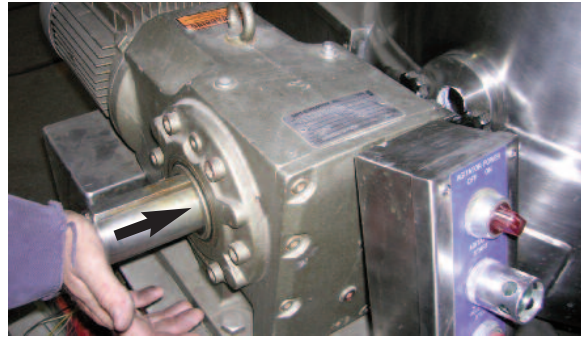

8. Insert new shaft.



9. Push new shaft past retaining ring groove and install retaining ring.



10. Tap shaft back to seat up against retaining ring.

11. Complete reassembly by reinstalling bolt and end cap.

FIELD CONVERSION INSTRUCTIONS -

Natural Gas to Propane Gas

Power Burner Gas Kettles

	BTU's per Hour	Gas Type	Water Column	# of Orifices
KGL-40,	140000	NAT	3.5	1
KGL-40-T,	140000	LP	3.5	1
MKGL-40-T,				
KGL-60 to 100,				
KGL-60-T to 80-T,				
KGL-40-TSH,	190000	NAT	3.5	1
KGL-40-F to 60-F,	190000	LP	3.5	1
KGL-40-SH to 60-SH,				
HA-MKGL-60 to 100,				
HA-MKGL-60 to 100-T				

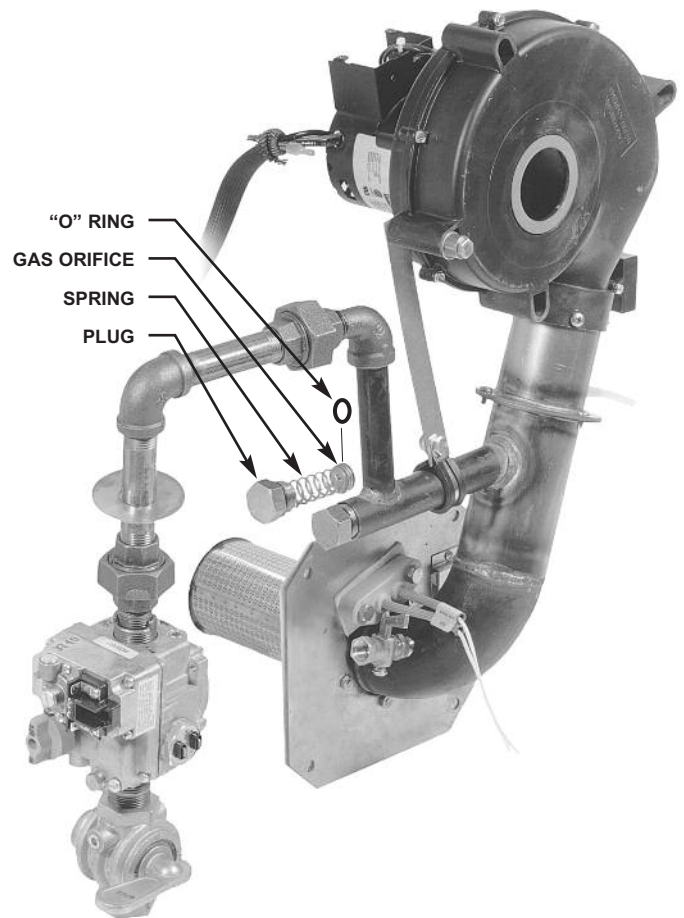
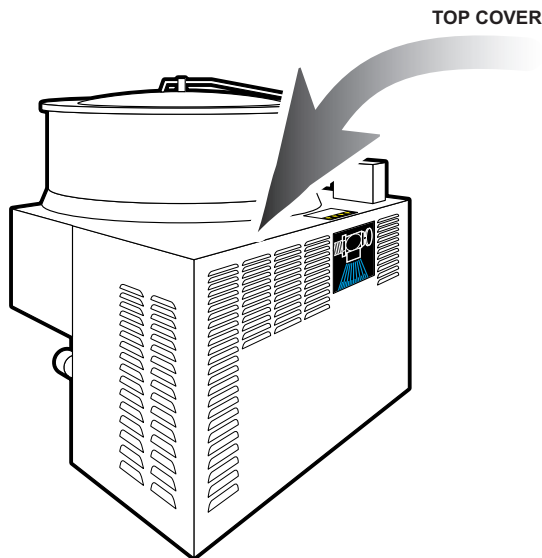

NOTE: Use thread sealant compatible with propane gas on all threaded piping connections.

1. Disconnect electrical connection.
2. Shut off main gas supply and disconnect kettle from supply line.
3. Remove **TOP COVER**.
4. Remove **PLUG** and **SPRING**.
5. Remove **GAS ORIFICE** and **"O" RING**.
6. Replace with new **GAS ORIFICE** and **"O" RING**.
7. Replace **SPRING** and **PLUG**.
8. Replace **TOP COVER**.
9. Place gas conversion label next to rating label.
10. Reconnect electrical supply.

Conversion Parts Required

KGL-40

Part No.	Description	Quantity
KE95549	Conversion Label	1
KE54420-1	Air Intake Washer	1
KE53403-5	Gas Orifice	1
FA05002-29	"O" Ring	1

KGL-60 to 100

Part No.	Description	Quantity
KE95549	Conversion Label	1
KE54420-1	Air Intake Washer	1
KE53403-7	Gas Orifice	1
FA05002-29	"O" Ring	1

SPARE PARTS LIST

The following is a spare parts listing of parts that wear during normal use or are apt to be misplaced during normal operation. These parts should be kept on hand to prevent loss time due to a minor problem.

PART NUMBER	DESCRIPTION	QUANTITY
KE54602	SCRAPER BLADE	1
KE54608	SPRING	3
KE01911	RETAINING KNOBS	1
FA05002-8	"O" RING	3
KE54594	PIN	1
KE54834-4	SOLENOID VALVE	1
KE55248	BUNA-N O-RING	5
KE55255	BUNA-N O-RING	5
FA05002-46	O-RING, FOOD GRADE, SIZE A0123, EPDM E 692-75	5
KE52154-3	GASKET, SANI CLAMP, 1 1/2" WHITE TEFLON	5
KE55297-3	GD2 STANDARD ACTUATOR	1
KE52936-2	FUSE, 15 AMP	6
SE50354	PEN TIP, RED (PKG. OF 5)	1
SE50354	PEN TIP, GREEN (PKG. OF 5)	1

The following is a recommended list of spare parts that may be required if the service agency is of some distance away or if down time must be kept to a minimum and spare parts are required for the service agent on site.

PART NUMBER	DESCRIPTION	QUANTITY
KE54834-4	SOLENOID VALVE	1
KE55253	AIR OPERATED CYLINDER	1
KE53469-4	IGNITION MODULE	1
KE00458	SOLID STATE CONTROL	1
KE50753-7	RELAY	1
KE00515	THERMISTOR	1
KE50753-10	RELAY, 120 V HOT COLD WATER BYPASS	1
KE02274	CAPACITOR ASSEMBLY	3
KE603208-9	CONTACTOR CARTRIDGE, NORMALLY OPEN	2
KE603208-8	CONTACTOR CARTRIDGE, NORMALLY CLOSED	2
KE50753-10	RELAY	1

AC INVERTER PROGRAMMING INSTRUCTIONS

The WFC Series AC Inverters come wired for external use and must be installed for use in a side panel control (See WIRING DIAGRAMS). Refer to owners manual for complete instructions and explanations. Manual used for the following was FORM 1094.

After installation is complete the inverter must be reprogrammed to Cleveland's modifications of the factory settings. All modifications are achieved in Access Level 2.

1. Turn agitator power on. The top four LED indicators will illuminate momentarily - wait for the three green LED's to go out before proceeding.
2. Press the PROGRAM and SHIFT keys simultaneously to reach Access Level 2. The display display will now read:
3. Use the UP/DOWN arrow keys to select the program parameter for change.
4. Press the SHIFT key. The program number will blink indicating that that the data value may be changed.
5. Use the UP/DOWN arrow keys to select the new data code.
6. Press the ENTER key. The display will indicate ****STORED**** for one second, then revert to the normal parameter display.
7. Press the PROGRAM key to exit the programming mode or the UP/DOWN keys to select an new parameter for change.

PROGRAM CODE SUMMARY:

#	Name	Description	Data Range	Factory Setting	Units	Access Level	Customer Setting
01	MODEL	Model Number	0-65000	Note 1	---	1	
02	RVLVL	Software Revision	0-640	Note 1	---	2	
03	IRAT	Rated Current	2-200	Note 1	A	2	
05	SERNO	Serial Number	0-65000	---	---	2	
06	REP	Repair Date	0-65000	---	---	2	
07	FLT3	Last Fault	---	---	---	1	
08	FLT2	2nd Fault	---	---	---	2	
09	FLT1	1st Fault	---	---	---	2	
12	FOUT	Output Frequency	0-400	---	Hz	1	
13	VOUT	Output Voltage	0-100	---	%	1	
14	IOUT	Output Current	0-650	---	A	1	
15	LOAD	Drive Load	0-200	---	%	1	
16	TORQ	Load Torque	0-200	---	%	1	
17	TEMP	Inverter Temp	2-105	---	C	1	
18	TIME1	Total Run Time	0-65000	---	h	2	
19	TIME2	Power On Hours	0-65000	---	h	2	
21	MODE	Input Mode	0-36	0	---	1	4
24	FSEL	Reference Select	0-18	0	---	2	
27	TLSEL	Torque Limit Select	0-6	0	---	2	
31	FMIN	Min. Frequency	0.00-400	0	Hz	1	14
32	FMAX	Max. Frequency	20.00-400	60	Hz	1	70
33	F2	Preset Speed #2 - Jog	0.00-400	5	Hz	1	
34	F3	Preset Speed #3	0.00-400	20	Hz	2	
35	F4	Preset Speed #4	0.00-400	40	Hz	2	
36	F5	Preset Speed #5	0.00-400	60	Hz	2	
37	F6	Preset Speed #6	0.00-400	0	Hz	2	
38	F7	Preset Speed #7	0.00-400	0	Hz	2	
39	FTL	Min. Frequency in Torque Limit	0.00-400	10	Hz	2	
41	RSEL	Ramp Selector	0-7	0	---	2	
42	ACC1	Acceleration Time #1	0.10-600	3	s	1	9

43	DEC1	Deceleration Time #1	0.10-600	3	s	1	1
44	ACC2	Acceleration Time #2	0.10-600	1	s	2	
45	DEC2	Deceleration Time #2	0.10-600	1	s	2	
46	DECTL	Torq. Limit Response Time	0.10-30	1	s	2	
47	DCBRK	DC Brake Time	0-5	0.2	s	2	
48	DCVLT	DC Brake voltage	0-15	Note1	%	2	
51	VSEL	V/Hz Characteristic Selector	0-5	0	---	2	2
52	BOOST	Torque Boost	0-25	Note 1	%	1	8
53	FKNEE	V/Hz Knee Frequency	26-640	60	Hz	2	75
54	SKBND	Skip Fresq. Hysteresis Band	0.20-20	1	Hz	2	
55	SK1	Skip Frequency #1	0.00-400	0	Hz	2	
56	SK2	Skip Frequency #2	0.00-400	0	Hz	2	
57	SK3	Skip Frequency #3	0.00-400	0	Hz	2	
58	SK4	Skip Frequency #4	0.00-400	0	Hz	2	
59	MVOLT	Rated Motor Voltage	185-480	Note 1	V	2	
61	LTLF	Load Torq. Limit Forward	5-150	150	%	2	
62	LTLR	Load Torq. Limit Reverse	5-150	150	%	2	
63	RTLFL	Regenerative Torq. Limit FWD	5-110	80	%	2	
64	RTLRL	Regenerative Torq. Limit REV	5-110	80	%	2	
65	SLIP	Slip Compensation	0-10*	0	%	1	
66	STAB	Current Stability	0-5	2	---	2	
67	TOL	Timed Overload Trip Point	0-100	0	%	2	100
68	NRST	Restart Number	0-8	0	---	2	
69	DRST	Restart Delay	0-60*	0	s	2	
6C	TOLC	Timed Overload Characteristic	0-7	0	---	2	
71	METER	Analog Meter Output	0-7	1	---	1	
72	ST1	Auxiliary Output #1	0-11	6	---	2	
73	ST2	Auxiliary Output #2	0-11	3	---	2	
74	ST3	Auxiliary Output #3	0-11	7	---	2	
75	STR	Auxiliary Relay (Fault)	0-11	2	---	2	3
81	PRGNO	Special Program Number	0-65000	0	---	2	2
82	START	Inverter Start Options	0-7	0	---	2	
83	PWM	Carrier Frequency Selector	0-1	0	---	2	1
84	DISP	Display Option Full Setting	0-65000	0	---	2	
85	UNITS	Display Units	ALPHA	RPM_1	---	2	
86	LANG	Display Language	0-3	0	---	2	
87	ACODE	Security Access Code	0-999	0	---	2	
A2	RATIO	Master Slave Speed Ratio (Note 2)	50-2000	100	%	2	
B1	OPTNO	Option Board Number	0-6	0	---	2	
Cx	CNTLx	Event Control (1-9)	BINARY (8)	0	---	2	
Ex	ECNTx	Event Counts (1-9)	0-65535	0	---	2	

Bolded areas indicate Cleveland modifications of factory settings.

WIRING DIAGRAM - 208-240V (Page 1 of 2)

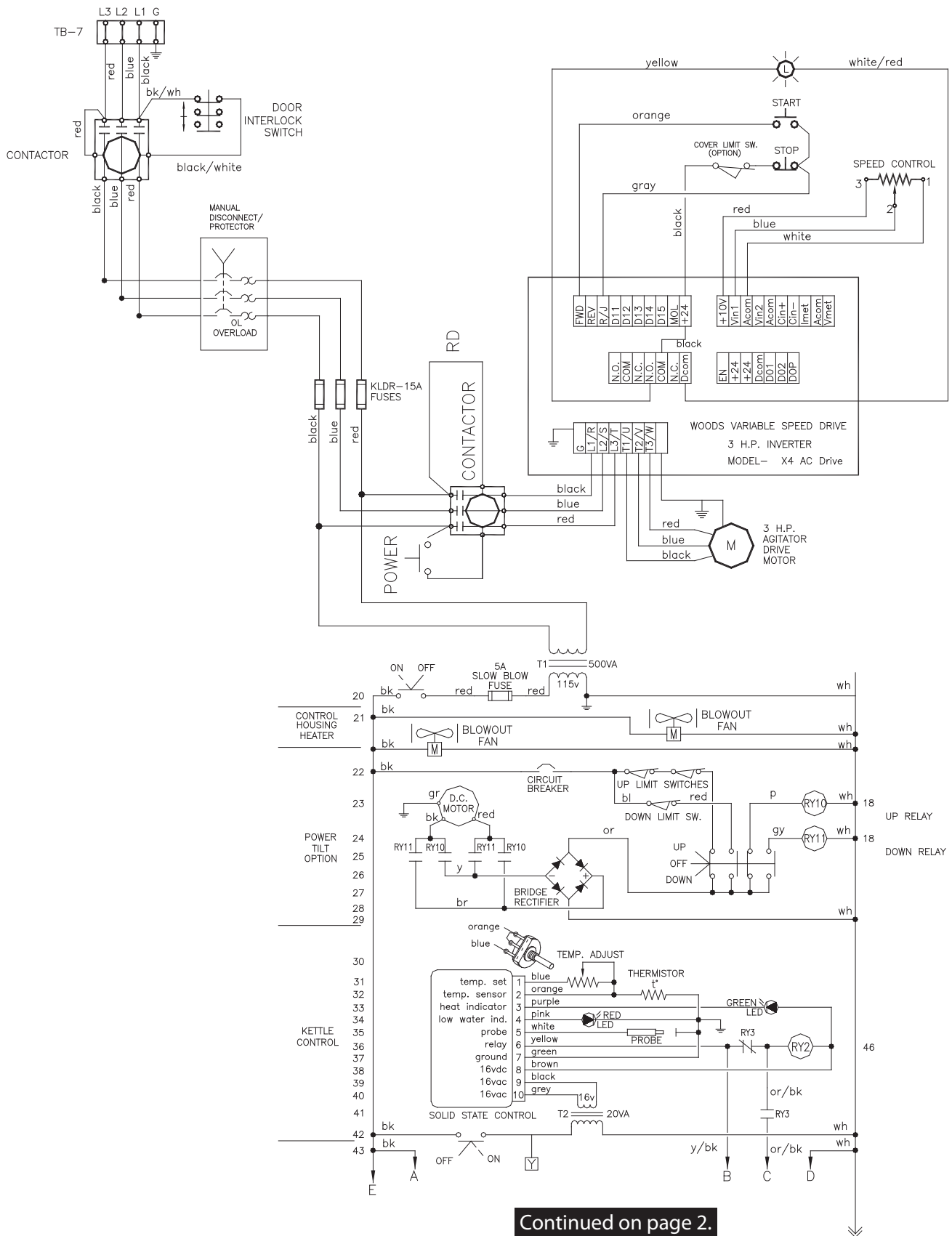

Continued on page 2.

WIRING DIAGRAM - 208-240V (Page 2 of 2)

Continued from page 1.

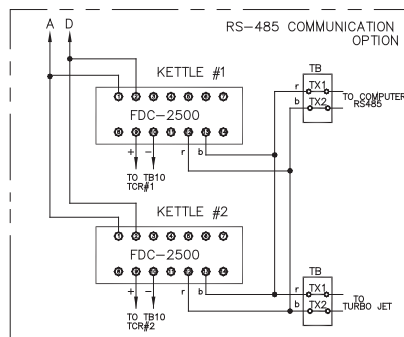
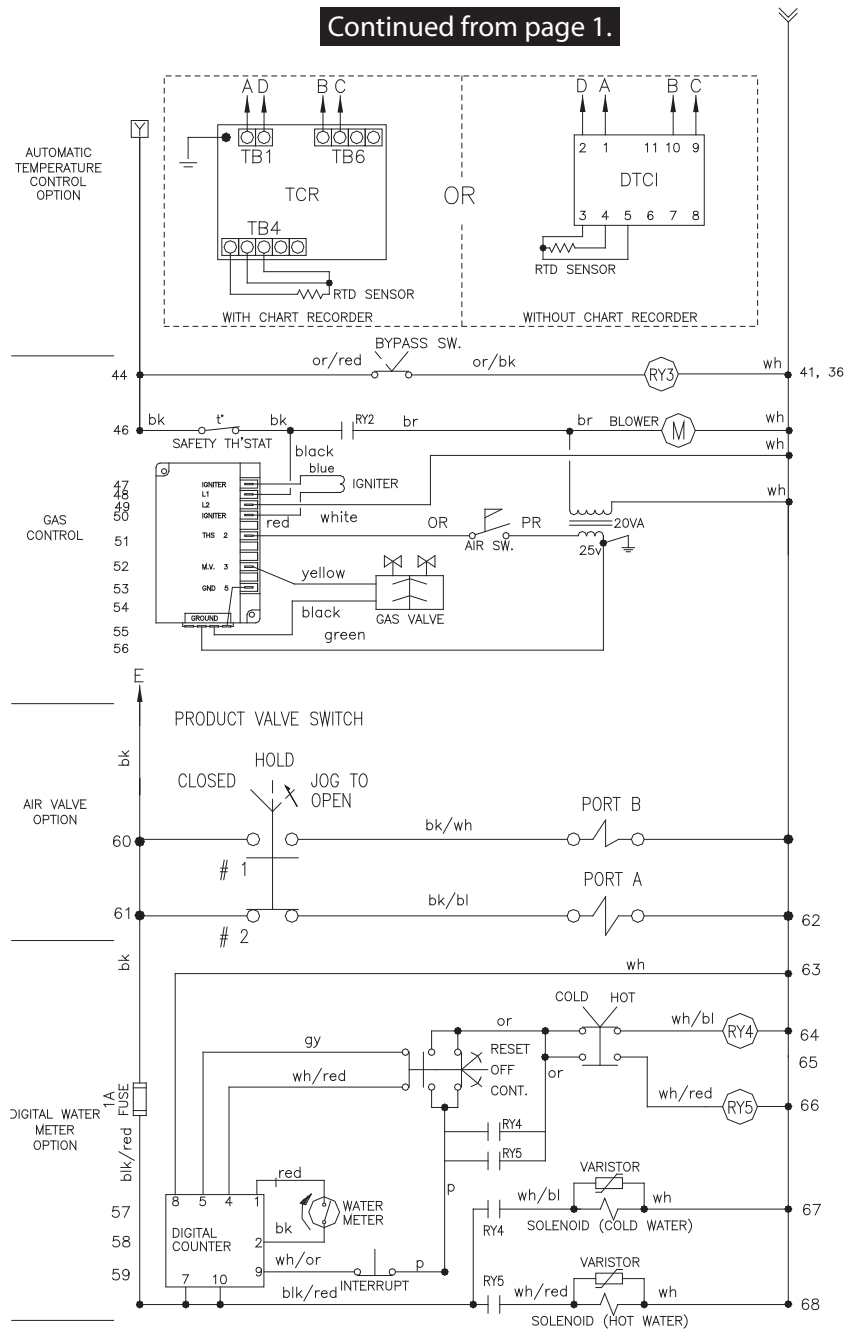

MAINTAINED, MAINTAINED, MOMENTARY

	#1	#2
SWITCH		
CLOSED	O	X
HOLD	O	O
JOG TO OPEN	X	O
CONTACT		

X = CLOSED
O = OPEN

HA-SG-CC (200-240 V)

WIRING DIAGRAM - 460-480V (Page 1 of 2)

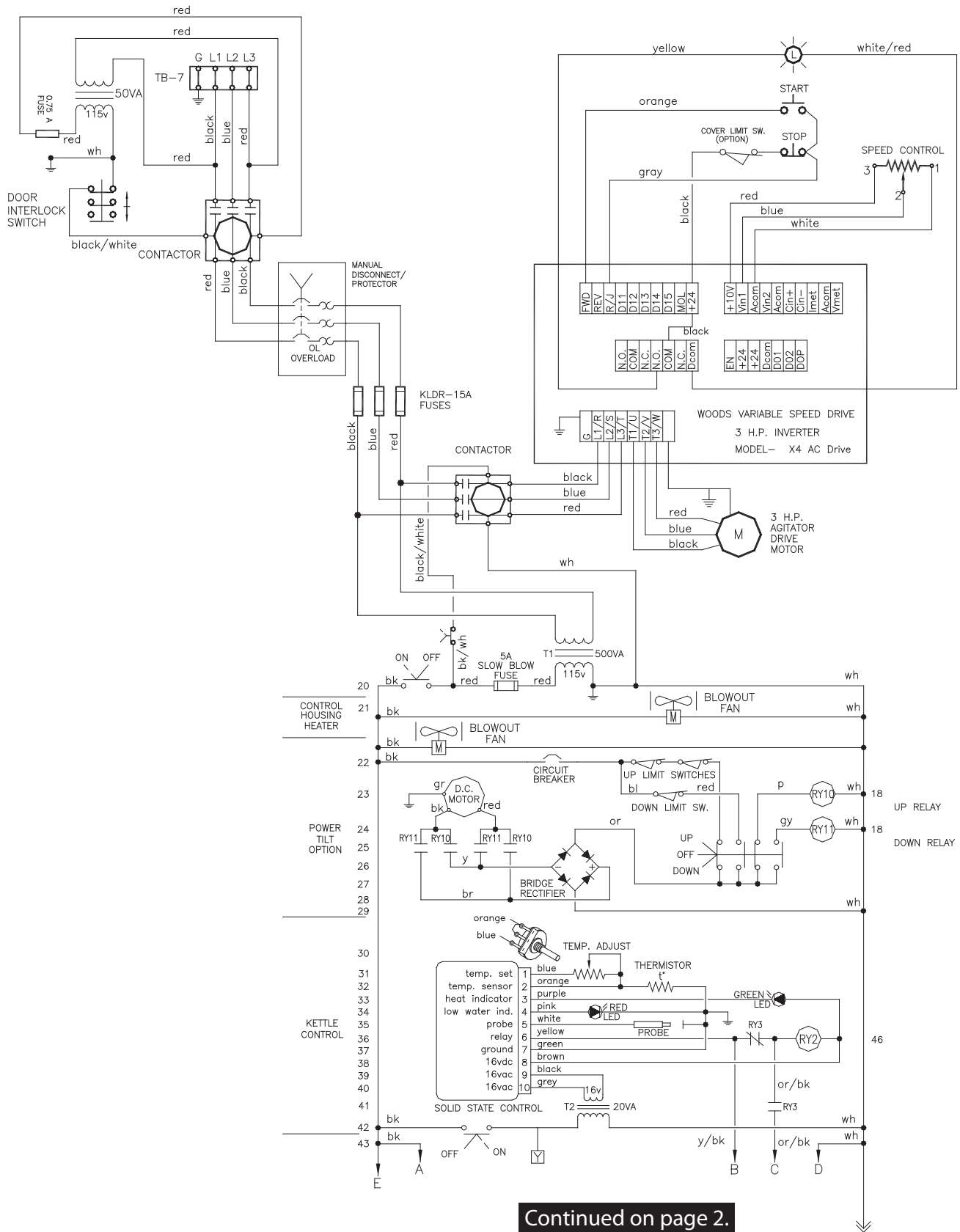

Continued on page 2.

WIRING DIAGRAM - 460-480V (Page 2 of 2)

Continued from page 1.

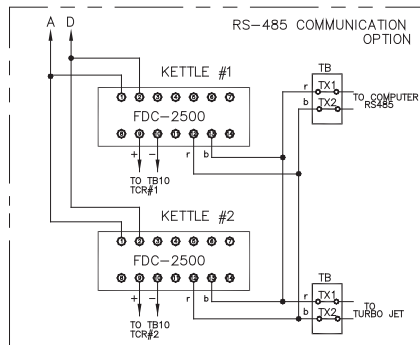
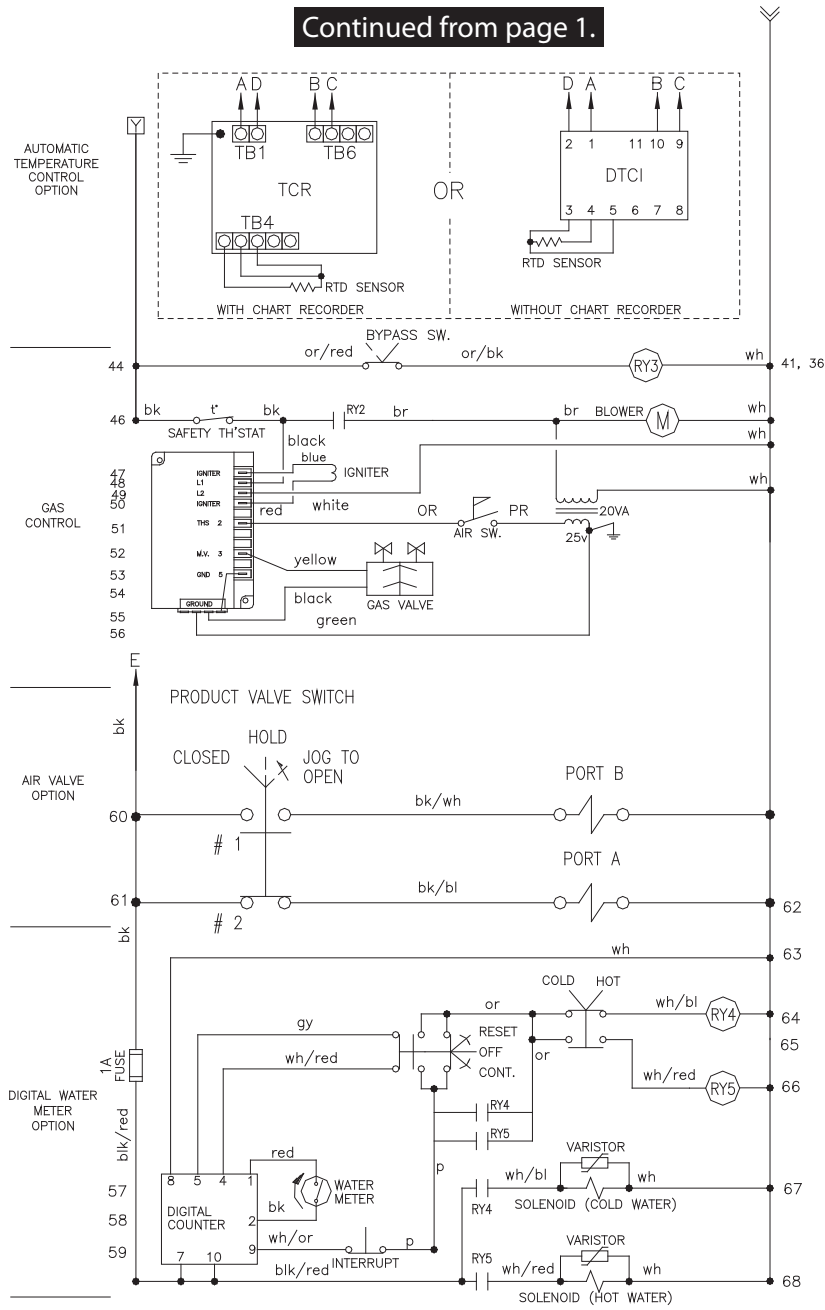

MAINTAINED, MAINTAINED, MOMENTARY

SWITCH	#1	#2	
CLOSED	O	X	
HOLD	O	O	
JOG TO OPEN	X	O	
CONTACT			

X = CLOSED
O = OPEN

HA-MKGL/-T WITH
ALL OPTIONS (460-480 V)