



Maintenance Procedures & Parts Lists

TR Electric Braising Pan

For units built after August 2011

SEL-30-TR
SEM-30-TR
SEL-40-TR
SEM-40-TR



For your future reference.

Model # _____

Serial # _____

Model # & Serial #.
(Open front panel to view rating label.)



1333 East 179th St., Cleveland, Ohio, U.S.A. 44110
Ph: 216.481.4900 Fx: 216.481.3782
www.clevelandrange.com



**Read the manual thoroughly.
Improper installation, operation or
maintenance can cause property
damage, injury or death.**

This manual is to be used in conjunction with the "Operators Manual". See "Operators Manual" for safety warnings, correct operation, installation and preventative maintenance.



STATEMENT OF RESPONSIBILITIES / DÉCLARATION DES RESPONSABILITÉS / DECLARACIÓN DE RESPONSABILIDADES

This document is for use by experienced and trained Qualified Cleveland Range, LLC Authorized Service Representatives who are familiar with both the safety procedures, and equipment they service. Cleveland Range, LLC assumes no liability for any death, injury, equipment damage, or property damage resulting from use of, improper use of, or failure to use the information contained in this document. Cleveland Range, LLC has made every effort to provide accurate information in this document, but cannot guarantee that this document does not contain unintentional errors and omissions.

The information in this document may be subject to technical and technological changes, revisions, or updates. Cleveland Range, LLC assumes no liability or responsibility regarding errata, changes, revisions, or updates.

Qualified Cleveland Range, LLC Authorized Service Representatives are obligated to follow industry standard safety procedures, including, but not limited to, OSHA regulations, and disconnect / lock out / tag out procedures for all utilities including steam, and disconnect / lock out / tag out procedures for gas, electric, and steam powered equipment and / or appliances.

All utilities (gas, electric, water and steam) should be turned OFF to the equipment and locked out of operation according to OSHA approved practices during any servicing of Cleveland Range equipment

Qualified Cleveland Range, LLC Authorized Service Representatives are obligated to maintain up-to-date knowledge, skills, materials and equipment.

Ce document est destiné à l'usage des Représentants de Service qualifiés et autorisés de Cleveland Range, LLC qui possèdent l'expérience et la formation ainsi que la bonne connaissance des mesures de sécurité et du matériel qu'ils entretiennent.

Cleveland Range, LLC décline toute responsabilité pour tout cas de décès, blessure, dommage matériel ou dommage aux biens résultant de l'utilisation, de la mauvaise utilisation ou du manquement d'utilisation des renseignements contenus dans ce document.

Cleveland Range, LLC s'est efforcé à fournir des renseignements précis dans ce document mais ne peut garantir que ce document soit exempt d'erreurs et d'omissions non intentionnelles.

Les renseignements contenus dans ce document peuvent être assujettis à des changements techniques et technologiques, des révisions ou des mises à jour.

Cleveland Range, LLC décline toute obligation ou responsabilité concernant les errata, modifications, révisions ou mises à jour.

Les Représentants de Service qualifiés et autorisés de Cleveland Range, LLC sont tenus de se conformer aux mesures de sécurité normalisées de l'industrie, y compris, mais sans s'y limiter, les réglementations de l'OSHA, les procédures de débranchement / verrouillage / étiquetage relatives à tous les services publics, dont l'approvisionnement en vapeur, et les procédures de débranchement / verrouillage / étiquetage relatives aux équipements et/ou appareils fonctionnant au gaz, à l'électricité et à la vapeur.

Au cours de tout entretien d'un appareil Cleveland Range, tous les services publics (gaz, électricité, eau et vapeur) doivent être FERMÉS au niveau de l'appareil et le dispositif de fonctionnement doit être verrouillé suivant les pratiques approuvées de l'OSHA.

Les Représentants de Service qualifiés et autorisés de Cleveland Range, LLC sont tenus d'actualiser en permanence leurs connaissances, compétences, matériel et équipement.

Este documento está destinado para el uso de los Representantes de Servicio calificados y autorizados de Cleveland Range, LLC quienes cuentan con la experiencia y la capacitación así como el buen conocimiento de las medidas de seguridad y de los equipos que mantienen.

Cleveland Range, LLC, declina toda responsabilidad en caso de cualquier fallecimiento, lesiones, daños al equipo o daños a la propiedad resultantes de la utilización, del uso indebido o de la falta de utilización de la información provista en este documento.

Cleveland Range, LLC se ha esforzado en suministrar información precisa en este documento, pero no puede garantizar que este documento esté exento de errores y de omisiones no intencionales.

La información contenida en este documento podría estar sujeta a cambios técnicos o tecnológicos, revisiones o actualizaciones. Cleveland Range, LLC declina toda obligación o responsabilidad con respecto a erratas, modificaciones, revisiones o actualizaciones.

Los Representantes de Servicio calificados y autorizados de Cleveland Range, LLC tienen la obligación de seguir los procedimientos estándar de seguridad de la industria; los cuales incluyen pero no se limitan a los reglamentos de la OSHA (La Administración de la Seguridad y Salud Ocupacionales), los procedimientos de desconexión, cierre y etiquetado relativos a todos los servicios públicos incluyendo el suministro de vapor y los procedimientos de desconexión, cierre y etiquetado para los equipos y/o aparatos que funcionan a base de gas, electricidad o vapor.

Cuando se esté dando servicio o mantenimiento a un aparato de Cleveland Range, todos los servicios públicos (gas, electricidad, agua y vapor) deben estar APAGADOS para el equipo en cuestión y se debe seguir el procedimiento de cierre de operaciones de acuerdo con las prácticas aprobadas por la OSHA.

Los Representantes de Servicio calificados y autorizados de Cleveland Range, LLC tienen la obligación de actualizar constantemente sus conocimientos, destrezas, materiales y equipamiento.

TROUBLESHOOTING AND MAINTENANCE PROCEDURES

The following trouble shooting guide and maintenance procedures are meant to be used by Qualified Service Technician



For periodic maintenance recommendations see “Operators Manual”.

HINGE ADJUSTMENT INSTRUCTIONS

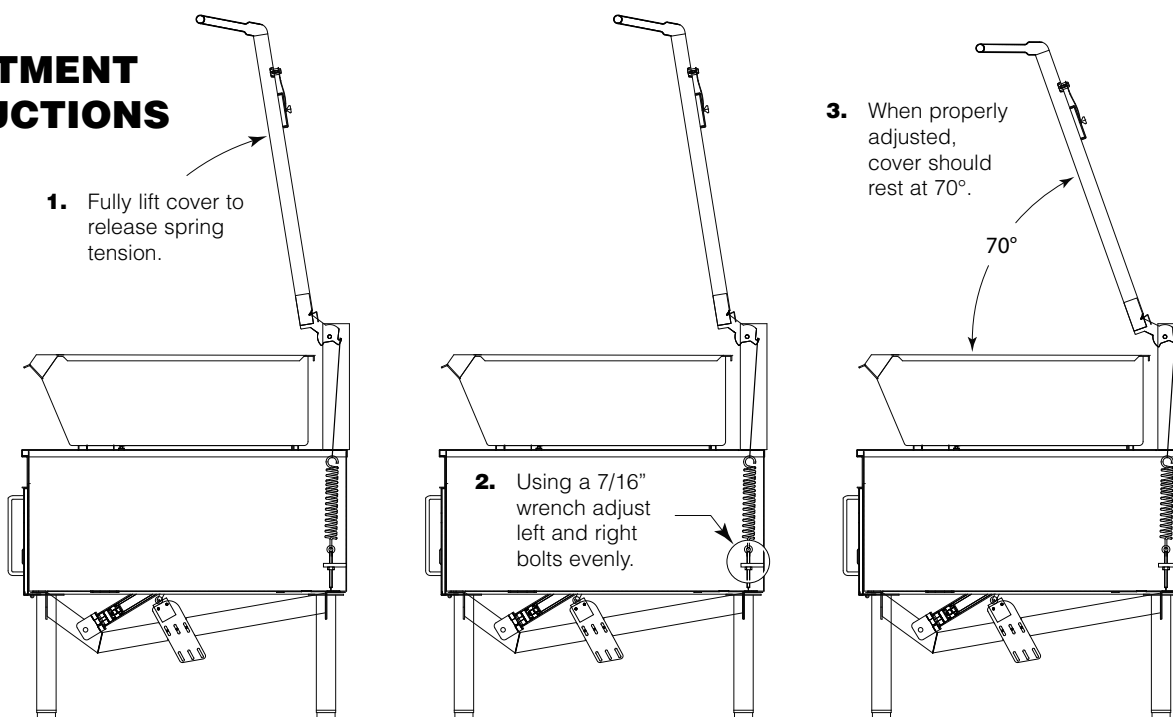

CALIBRATION INSTRUCTIONS

IMPORTANT: DO NOT ATTEMPT TO CALIBRATE THE THERMOSTAT

The electronic thermostat supplied with this skillet has been precisely calibrated at the factory and should not require field calibration.

RECOMMENDED SPARE PARTS LIST

ITEM ON.	DESCRIPTION	QTY.
KE55069-7	SAFETY THERMOSTAT	1
SK50905-2	LIGHT	1
KE52936-13	FUSE, 1 AMP, 250V	1
SK2498399	SHAFT ASSEMBLY, POTENTIOMETER	1
SK2474100	SWITCH, OP/OFF, 120V	1
KE603902-7	CONTACTOR	2
SK53838-30	TRANSFORMER	1
SK2343502	SWITCH, POWER TILT	1
KE52936-9	FUSE, 15 AMP, 250 V	1
SK2345100	THERMOSTAT SENSOR	1
SK2142002	TEMPERATURE SENSOR BOARD	1

SERVICE PARTS

WARRANTY

Our Company supports a worldwide network of Maintenance and Repair Centers. Contact your nearest Maintenance and Repair Centre for replacement parts, service, or information regarding the proper maintenance and repair of your cooking equipment.

In order to preserve the various agency safety certification (UL, NSF, ASME/Ntl. Bd., etc.), only factory-supplied replacement parts should be used. The use of other than factory supplied replacement parts will void warranty.

FAUCET ASSEMBLY

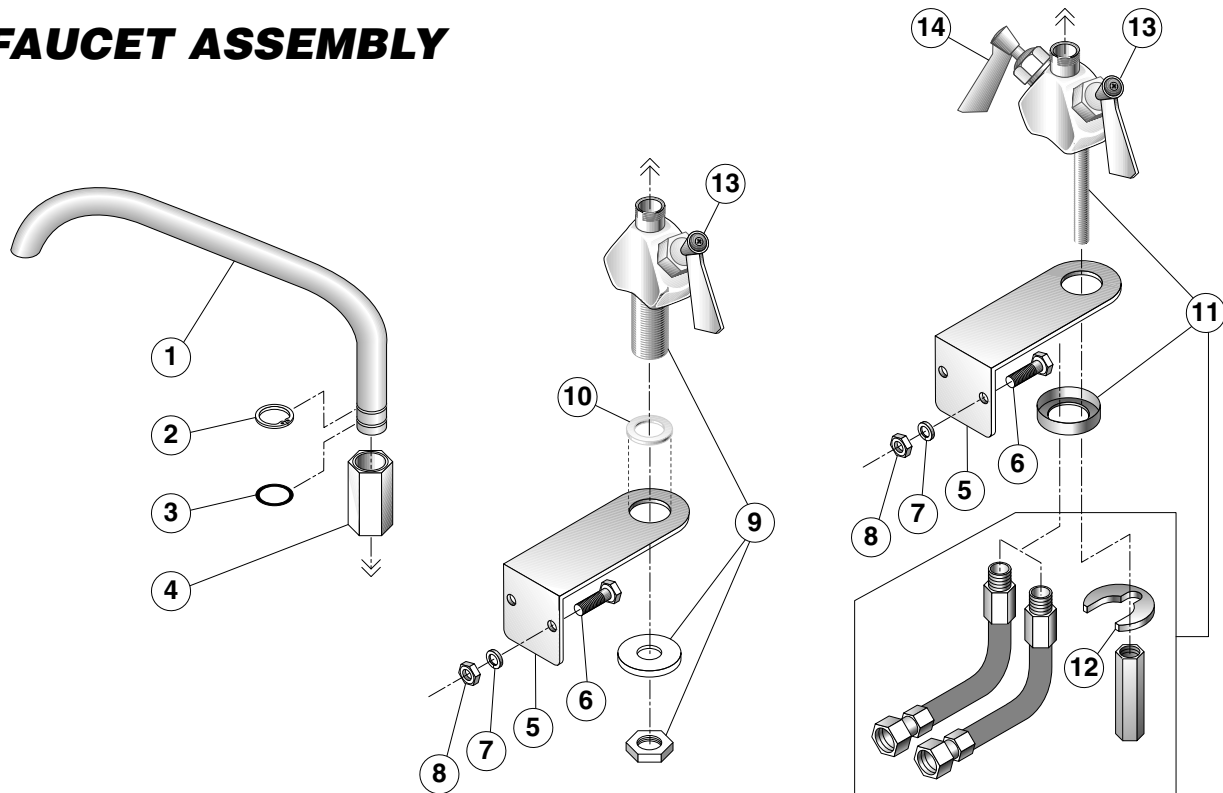

ITEM #	PART #	DESCRIPTION	QTY.
	SPK14	SINGLE PANTRY FAUCET (includes items 1-10)	
	DPK14	DOUBLE PANTRY FAUCET (includes items 1-8 & 11)	
1.	KE50825-6	3/4" SPOUT	1
2.	FA95007-10	RETAINING RING	1
3.	FA05002-19	"O" RING	1
4.	KE51736	LONG FAUCET NUT	1
5.	SK2382300	FAUCET MOUNTING BRACKET	1
	SK2382400	SPACER, FOR BRACKET	1
6.	FA11258	HEX CAP SCREW	2
7.	FA31029	LOCK WASHER	2
8.	FA21008	HEX NUT	2
9.	KE51401	SINGLE PANTRY BODY (c/w item 13)	1
10.	KE50335	ADAPTER WASHER	1
11.	KE51403	DOUBLE PANTRY BODY (c/w item 13 & 14)	1
12.	SE50447	REPLACEMENT HORSESHOE WASHER	1
13.	SE50021	REPLACEMENT STEM ASSEMBLY, COLD WATER	1
14.	SE50020	REPLACEMENT STEM ASSEMBLY, HOT WATER	1

POWER TILT ASSEMBLY

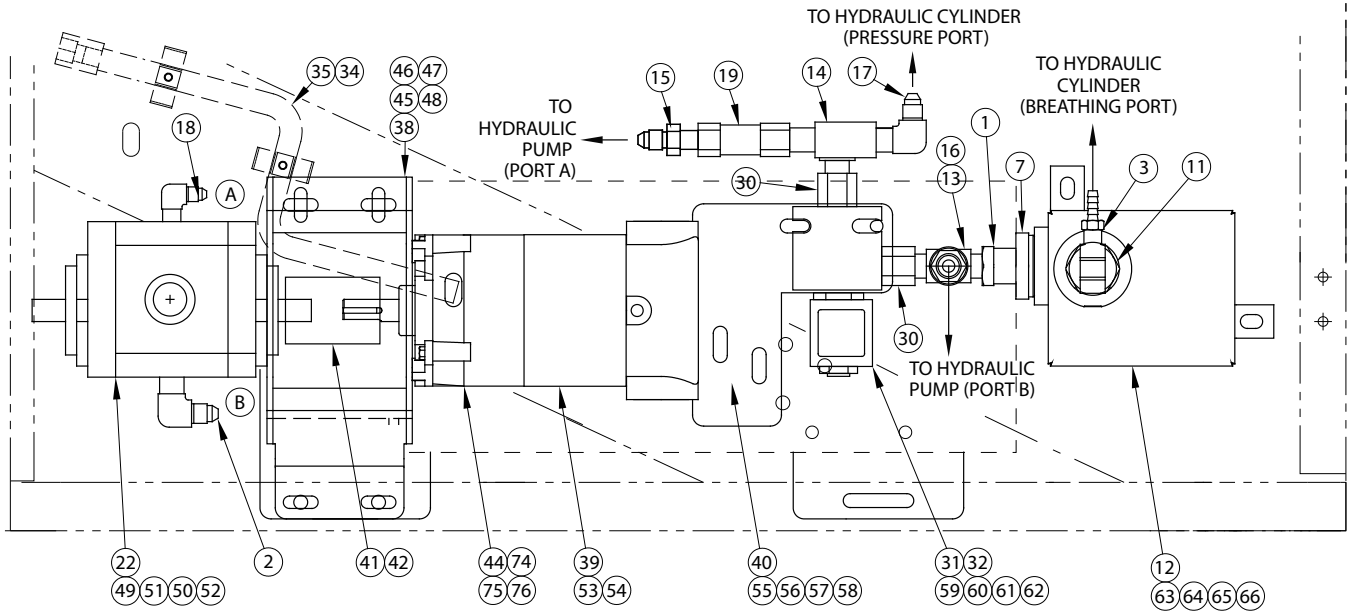

ITEM	PART #	DESCRIPTION	QTY.
1	FI00351	HEX BUSHING;1/2 X 1/4	1
2	FI05059	ELBOW; STRAIGHT THREAD	1
3	FI05318-1	ELBOW HOSE BARB 90 BRASS	1
4	KE000523	HYDRAULIC JACK ASSY TR/F	1
5	KE53143	PLUG; 1/4-18 HYDRAULIC	1
6	KE55267	FLOW RESTRICTOR MT/TR	1
7	KE600452	STRAINER; OIL (MT-TR/F)	1
8	KE603728	COVER; CONTROL SWITCHES	1
9	M194	HYDRAULIC OIL; HD68-4L	1
10	SK2147401	FITTING;LIQUID TIGHT	1
11	SK2250700	PLUG MODIFD FI00285	1
12	SK2375699	OIL TANK ASSY MT/TR	1
13	SK2378900	TEE; 1/4 P (M/F/M)	1
14	SK2378901	TEE; 1/4 P (F/M/M)	1
15	SK2379000	ADAPTER; 1/4 P	1
16	SK2379001	ADAPTER; 1/4 P	1
17	SK2379100	ELBOW;1/4-90D-	2
18	SK2379200	ELBOW;O'RING BOSS 90DEG	1
19	SK2379400	CHECK VALVE PARKER C400B	1
21	KE95586-2	LABEL; CLEVELAND/PT/TR	1
22	SK2378802	HYDRAULIC PUMP; TR/F	1
23	SK2379501	HYDRAULIC HOSE ASSY;22	2
24	KE50581	BRIDGE RECTIFIER; #MB256	1
25	KE52936-9	FUSE; 15A/250V/MDA-15-R	1
26	SK1427305	CAPACITOR;4700MF/63VDC	1
27	SK2282100	CAPACITOR; CLAMP #VR3	1
28	SK2343502	SWITCH; TILT SWITCH	1
29	KE601979	LIMIT SW ;TR- (UL APPV)	1
30	KE603895	HYDRAULIC HOSE ADAPTER	2
31	KE54834-17	SOLENOID VALVE	1
32	KE603873	SOLENOID VALVE CONNECTOR	1
33	KE003707	HYDRAULIC HOSE ASSY	1
34	KE003160	HANDLE MANUAL CRANK	1
35	SK2473800	CLIP; SMALL	2
36	F10	PAN QUAD SCR #8-32X3/8	2
37	KE54907-1	PLUG BUTTON	1
38	KE003705	MOTOR MOUNT BRACKET ASS'Y	1
39	KE603896	GEARMOTOR, DC	1
40	KE603898	SOLENOID MOUNTING PLATE	1
41	KE50582-5	COUPLING HUB 1/2 DIA.	2
42	KE50583-1	SPIDER	1
43	SK2147402	LIQUID TIGHT FITTING	1
44	KE603951	GEAR MOTOR COVER	1

ITEM	PART #	DESCRIPTION	QTY.
FASTENERS FOR THE MOTOR MOUNT BRACKET ASSY			
45	FA11260	HEX BOLTS S.S., 1/4-20UNC X 1"	4
46	FA30505-1	FLAT WASHER S.S., 1/4	8
47	FA31029	LOCK WASHER S.S., 1/4	4
48	FA21008	HEX NUT S.S., 1/4-20UNC	4
FASTENERS FOR THE HYDRAULIC PUMP			
49	FA11325	HEX BOLTS S.S., 15/16-18UNC X 1 1/4"	2
50	FA30505-5	FLAT WASHER S.S., 5/16	2
51	FA31030	LOCK WASHER S.S., 5/16	2
52	FA21024	HEX NUT S.S., 5/16-18UNC	2
FASTENERS FOR GEARMOTOR			
53	FA11148	10-32UNF X 3/4 PAN PHIL M/S 18-8 S.S.	4
54	FA32022	EXT. TOOTH LOCK WASHER S.S., #10	4
FASTENERS FOR SOLENOID MOUNTING PLATE			
55	FA11260	HEX BOLTS S.S., 1/4-20UNC X 1"	2
56	FA30505-1	FLAT WASHER S.S., 1/4	4
57	FA31029	LOCK WASHER S.S., 1/4	2
58	FA21008	HEX NUT S.S., 1/4-20UNC	2
FASTENERS FOR SOLENOID VALVE			
59	FA11509-4	HEX BOLTS S.S., 1/4-20UNC X 1 3/4"	2
60	FA30505-1	FLAT WASHER S.S., 1/4	4
61	FA31029	LOCK WASHER S.S., 1/4	2
62	FA21008	HEX NUT S.S., 1/4-20UNC	2
FASTENERS FOR TANK			
63	FA11148	10-32UNF X 3/4 PAN PHIL M/S 18-8 S.S.	1
64	FA32022	EXT. TOOTH LOCK WASHER S.S., #10	1
65	FA30505-2	FLAT WASHER S.S., #10	1
66	FA21006	HEX NUTS 18-8 S.S., #10-24UNC	1
FASTENERS FOR TILTING LIMIT SWITCH			
67	FA11148	10-32UNF X 3/4 PAN PHIL M/S 18-8 S.S.	2
70	FA30505-9	SAE FLAT WASHERS S.S., 1/4	2
71	FA31029	LOCK WASHERS 18.8, 1/4	2
73	FA11260	HEX BOLTS S.S., 1/4-20UNC X 1"	2
PAN WITH TD OPTION			
72	KE603877-1	LIMIT SWITCH MOUNTING BRACKET	1
PAN WITHOUT TD OPTION			
72	KE603877-2	LIMIT SWITCH MOUNTING BRACKET	1
TO ORDER COMPLETE ASSEMBLY:			
72	SK003706-1	FOR UNITS WITH TD OPTION	1
72	SK003706-3	FOR UNITS WITH OUT TD OPTION	1

ITEMS 4, 5, 6, 7, 8, 9, 10, 21, 23, 24, 25, 26, 27, 28, 29, 33, 36, 37, 43, 67, 70, 71, 72 & 73 NOT SHOWN

MANUAL TILT ASSEMBLY

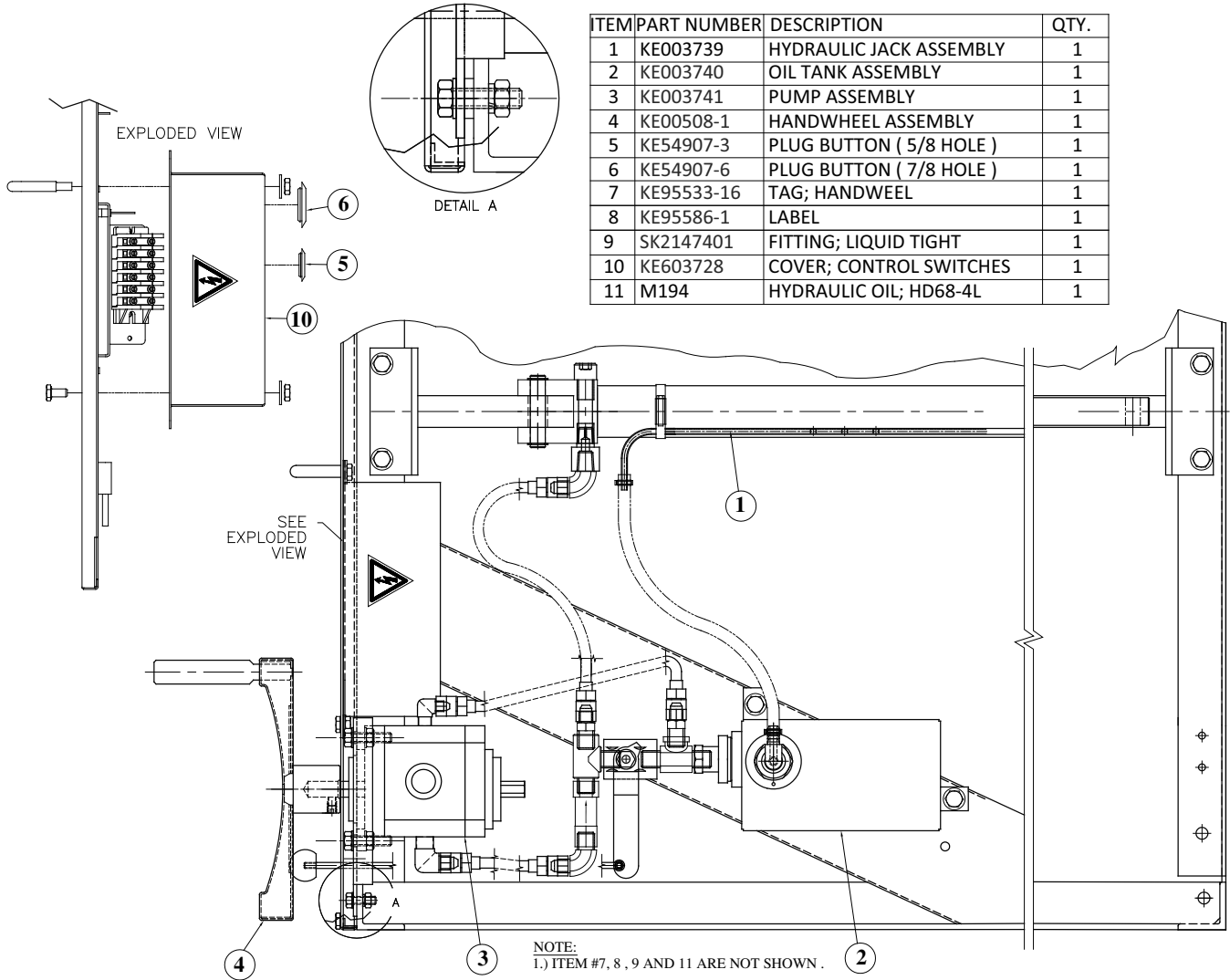

ITEM	PART NUMBER	DESCRIPTION	QTY.
1	KE003739	HYDRAULIC JACK ASSEMBLY	1
2	KE003740	OIL TANK ASSEMBLY	1
3	KE003741	PUMP ASSEMBLY	1
4	KE00508-1	HANDWHEEL ASSEMBLY	1
5	KE54907-3	PLUG BUTTON (5/8 HOLE)	1
6	KE54907-6	PLUG BUTTON (7/8 HOLE)	1
7	KE95533-16	TAG; HANDWEEL	1
8	KE95586-1	LABEL	1
9	SK2147401	FITTING; LIQUID TIGHT	1
10	KE603728	COVER; CONTROL SWITCHES	1
11	M194	HYDRAULIC OIL; HD68-4L	1

KE003746

HYDRAULIC JACK ASSEMBLY

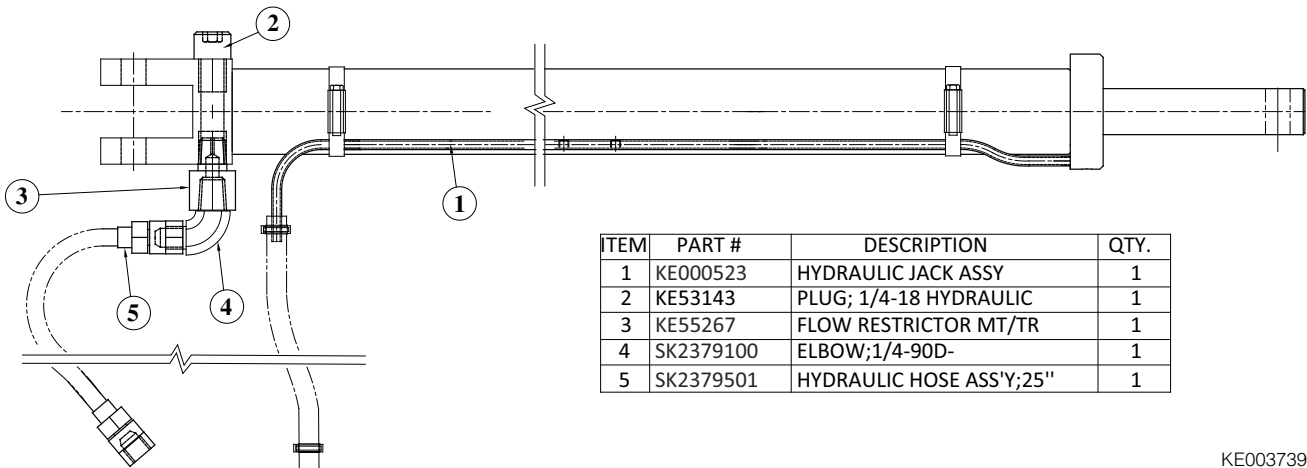

ITEM	PART #	DESCRIPTION	QTY.
1	KE000523	HYDRAULIC JACK ASSY	1
2	KE53143	PLUG; 1/4-18 HYDRAULIC	1
3	KE55267	FLOW RESTRICTOR MT/TR	1
4	SK2379100	ELBOW;1/4-90D-	1
5	SK2379501	HYDRAULIC HOSE ASS'Y;25"	1

KE003739

OIL TANK ASSEMBLY

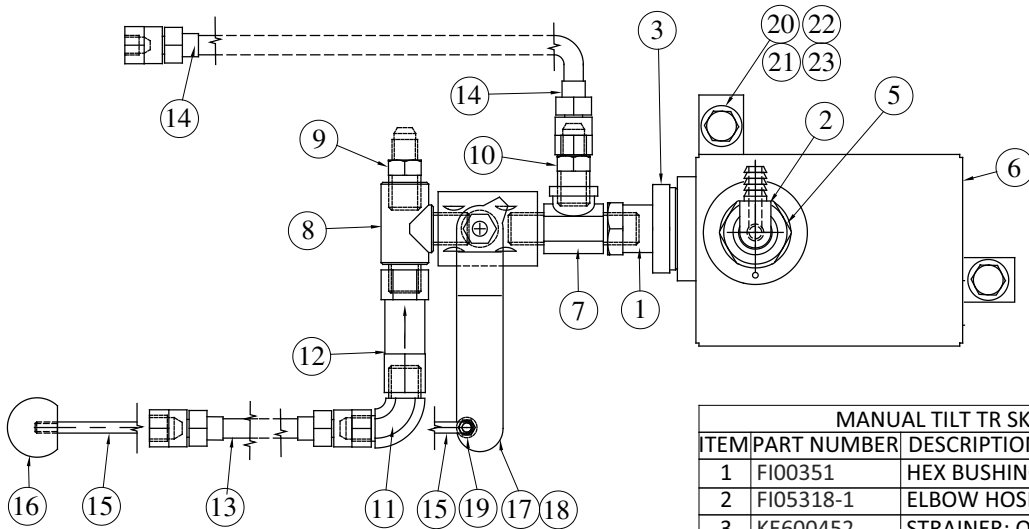

MANUAL TILT TR SKILLET ASSEMBLY			
ITEM	PART NUMBER	DESCRIPTION	QTY.
1	FI00351	HEX BUSHING;1/2 X 1/4	1
2	FI05318-1	ELBOW HOSE BARB 90 BRASS	1
3	KE600452	STRAINER; OIL (MT-TR/F)	1
5	SK2250700	PLUG MODIFD FI00285	1
6	SK2375699	OIL TANK ASSY MT/TR	1
7	SK2378900	TEE; 1/4 P (M/F/M)	1
8	SK2378901	TEE; 1/4 P (F/M/M)	1
9	SK2379000	ADAPTER; 1/4 P	1
10	SK2379001	ADAPTER; 1/4 P	1
11	SK2379100	ELBOW;1/4-90D-	1
12	SK2379400	CHECK VALVE PARKER C400B	1
13	SK2379500	HYDRAULIC HOSE ASS'Y;8"	1
14	SK2379600	HYDRAULIC HOSE ASS'Y.	1
15	SK2376200	LINK ROD	1
16	SK078279-1	BALL KNOB	1
17	SK2379301	BALL VALVE	1
18	SK2382700	VALVE RETURN SPRING	1
19	FA20504-3	LOCK NUT #10	1
20	FA11260	HEX BOLT S.S. 1/4-20 X 1	2
21	FA30505-1	FLAT WASHER S.S 1/4	2
22	FA31029	LOCK WASHER S.S 1/4	2
23	FA21008	HEX NUT S.S 1/4	2

KE003740

PUMP ASSEMBLY

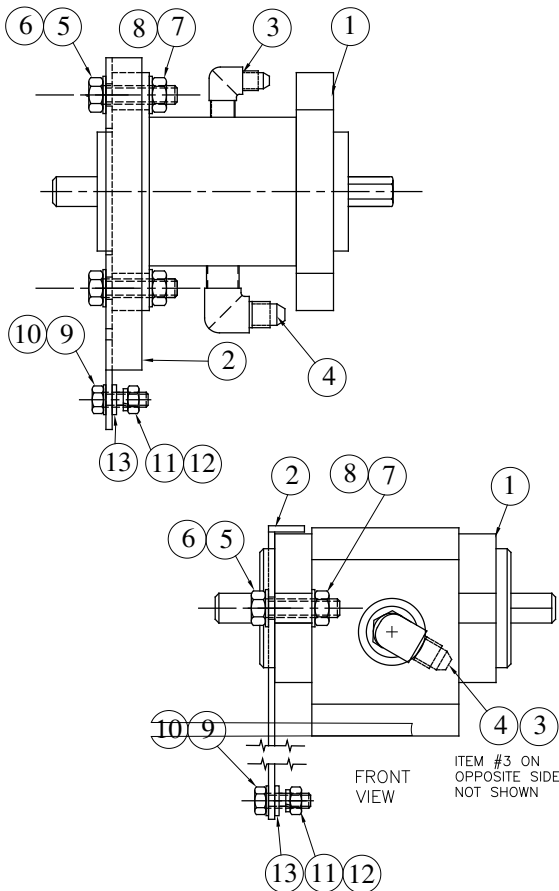

KE003741

ITEM	PART NUMBER	DESCRIPTION	QTY.
1	SK2378802	HYDRAULIC PUMP; TR/F	1
2	SK2376000	PUMP MOUNT BRACKET	1
3	FI05059	ELBOW; STRAIGHT THREAD	1
4	SK2379200	ELBOW;O'RING BOSS 90DEG	1
5	FA11325	HEX BOLT S.S. 5/16-18 X 1 1/4	2
6	FA30505-5	FLAT WASHER S.S 5/16	2
7	FA21024	HEX NUT S.S. 5/16-18	2
8	FA31030	SPLIT LOCKWASHER S.S 5/16	2
9	FA11260	HEX BOLT S.S. 1/4-20 X 1	3
10	FA30505-1	FLAT WASHER S.S 1/4	3
11	FA31029	LOCK WASHER S.S 1/4	3
12	FA21008	HEX NUT S.S 1/4	3
13	FA30504	FLAT WASHER 0.328 X 0.625	3

OIL TANK ASSEMBLY

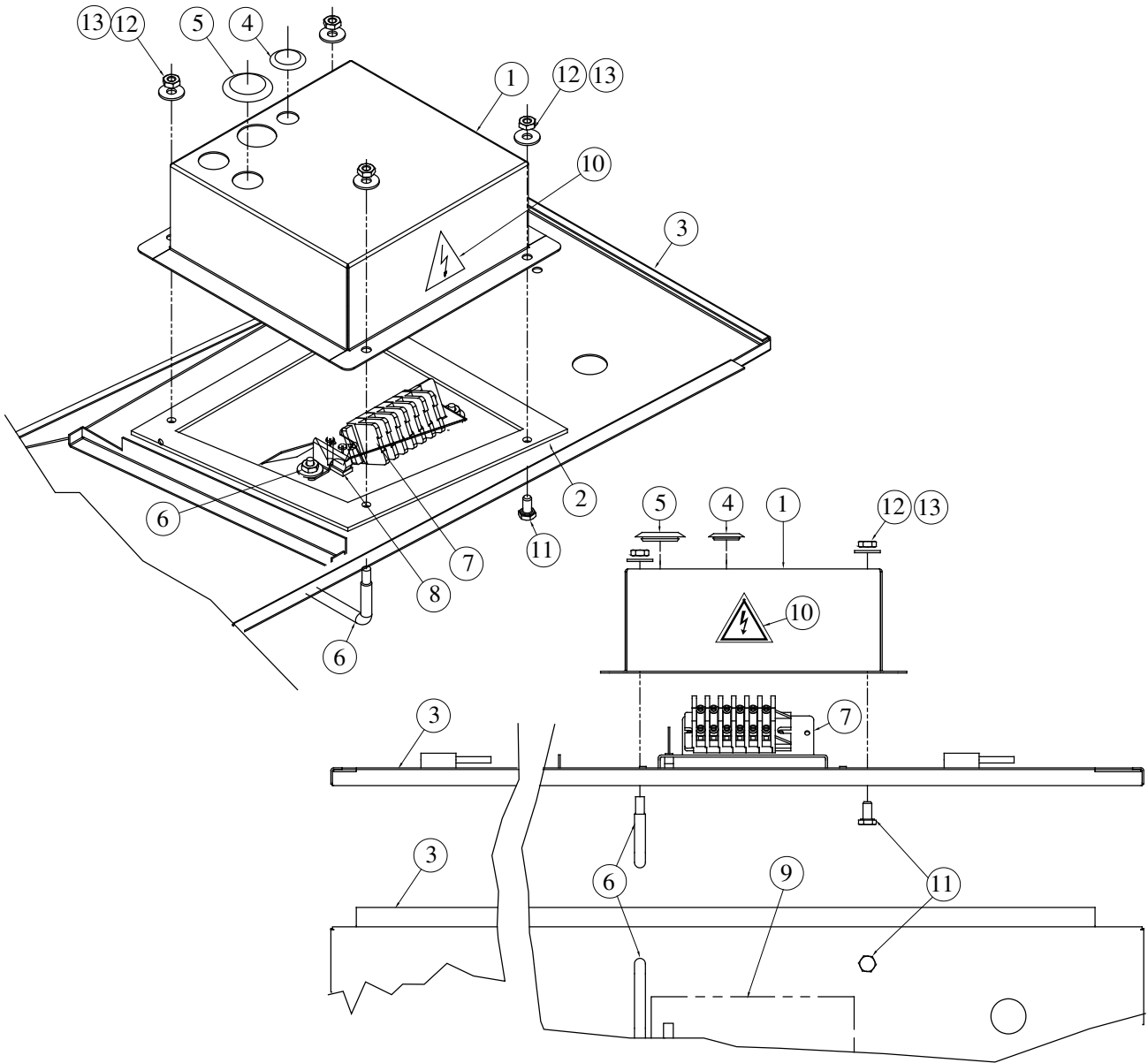

KE003742

KE003742-1 PANEL ASSEMBLY SGL-30-TR			
ITEM	PART NUMBER	DESCRIPTION	QTY.
1	KE603728	COVER; CONTROL SWITCHES	1
2	KE603729	GASKET	1
3	SK00383-4	CONTROL PANEL ASS'Y 30 GAL	1
4	KE54907-3	PLUG BUTTON (5/8 HOLE)	1
5	KE54907-6	PLUG BUTTON (7/8 HOLE)	1
6	KE601005	SWITCH GUARD	1
7	KE603726	TERMINAL BLOOCK BRACKET	1
8	SK50905-1	28V INDICATOR CLEAR LIGHT	1
9	KE95586-1	LABEL; TR SKILLETS	1
10	KE95497	LABEL; RISK OF EL. SHOCK	1
11	FA11260	HEX BOLT S.S. 1/4-20 X 1	2
12	FA30505-1	FLAT WASHER S.S 1/4	4
13	FA21008	HEX NUT S.S 1/4	4
14	FA20504-3	LOCK NUT #10	2

KE003742-2 PANEL ASSEMBLY SGL-40-TR			
ITEM	PART NUMBER	DESCRIPTION	QTY.
1	KE603728	COVER; CONTROL SWITCHES	1
2	KE603729	GASKET	1
3	SK00383-3	CONTROL PANEL ASS'Y 40 GAL	1
4	KE54907-3	PLUG BUTTON (5/8 HOLE)	1
5	KE54907-6	PLUG BUTTON (7/8 HOLE)	1
6	KE601005	SWITCH GUARD	1
7	KE603726	TERMINAL BLOOCK BRACKET	1
8	SK50905-1	28V INDICATOR CLEAR LIGHT	1
9	KE95586-1	LABEL; TR SKILLETS	1
10	KE95497	LABEL; RISK OF EL. SHOCK	1
11	FA11260	HEX BOLT S.S. 1/4-20 X 1	2
12	FA30505-1	FLAT WASHER S.S 1/4	4
13	FA21008	HEX NUT S.S 1/4	4
14	FA20504-3	LOCK NUT #10	2

CONTROL PANEL

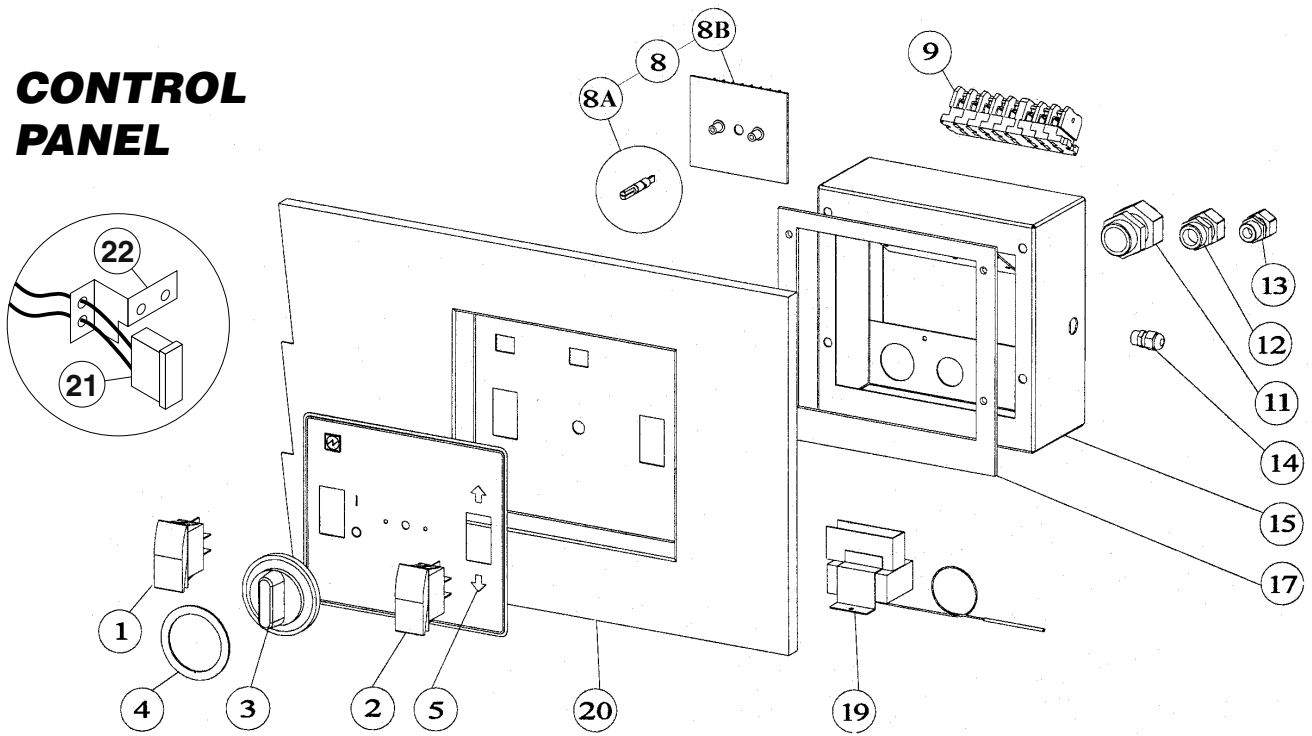

ITEM NO.	PART NO.	DESCRIPTION	QTY.
1	SK2474101	POWER SWITCH	1
2	SK2343502	TILT SWITCH (POWER TILT ONLY)	1
3	SK2138700	DIAL KNOB	1
4	SK2360701	DIAL INSERT °C	1
	SK2360700	DIAL INSERT °F	1
5	SKKE95586-1	LABEL, CLEVELAND, MANUAL TILT	1
	KE95586-2	LABEL, CLEVELAND, POWER TILT	1
8	SE00119	ELECTRONIC THERMOSTAT KIT (INCLUDES 8A & 8B)	1
8A	SK2142002	ELECTRONIC THERMOSTAT	1
8B	SK2498399	SHAFT ASSY.	1
9	SK50872-1	TERMINAL BLOCK	16
	SK50872-2	TERMINAL END	3
	KE603726	TERMINAL BLOCK BRACKET	1
11	SK2147403	LIQUID-TIGHT FITTING 5/8"	1
12	SK2147402	LIQUID-TIGHT FITTING 3/8"	1
13	SK2147401	LIQUID-TIGHT FITTING 5/16" (POWER TILT ONLY)	1
14	SK2147400	LIQUID-TIGHT FITTING 3/16"	1
15	KE603728	COVER, CONTROL SWITCHES	1
17	KE603729	NEOPRENE GASKET	1
19	KE55069-7	HIGH LIMIT	1
20	SK00383-1	CONTROL PANEL, POWER TILT, 40-TR	1
	SK00383-2	CONTROL PANEL, POWER TILT, 30-TR	
	SK00383-3	CONTROL PANEL, MANUAL TILT, 40-TR	1
	SK00383-4	CONTROL PANEL, MANUAL TILT, 30-TR	1
21	SK50905-2	INDICATOR LIGHT (ELECTRIC MODELS)	1
22	SK50903-1	BRACKET	1

SHAFT ASSEMBLY

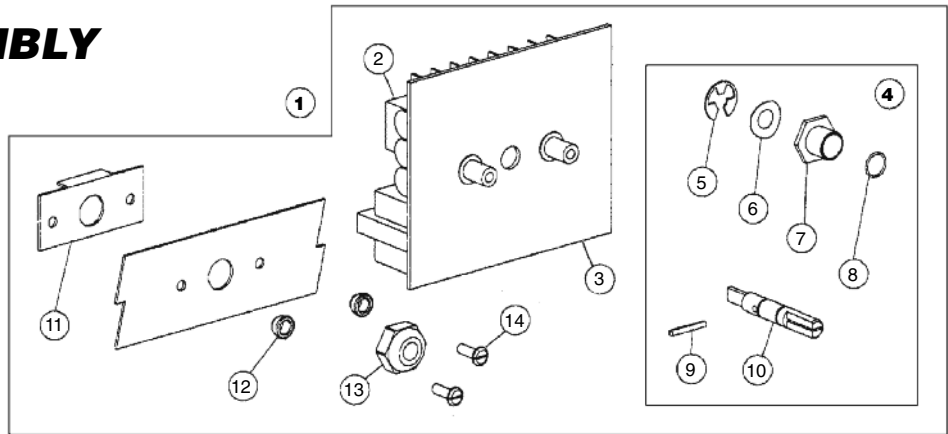

ITEM NO.	PART NO.	DESCRIPTION	QTY.
1.	SE00119	THERMOSTAT BOARD ASSEMBLY (INCLUDES 2 - 14)	1
2.	SK2142002	TEMPERATURE SENSOR BOARD	1
3.	SK2159300	INSULATOR, THERMOSTAT	1
4.	SK2498399	POTENTIOMETER SHAFT ASSEMBLY (INCLUDES 5-10)	1
5.	SK2167200	RETAINING RING, SP-NR #R1000-25	1
6.	SK2167100	WASHER, BOWED/SPRING	1
7.	SK2167300	PANEL BEARING	1
8.	SK2382800	RETAINING RING CLIP	1
9.	SK2167000	TENSION PIN	1
10.	SK2166800	POTENTIOMETER SHAFT	1
11.	SK2491500	STOP PLATE ASSY.	1
12.	KE55242-2	SEALER WASHER	2
13.	KE51005	ROTARY SHAFT SEAL	1
14.	FA11056	SCREW 6-32 X 1/8	2

PAN HINGE

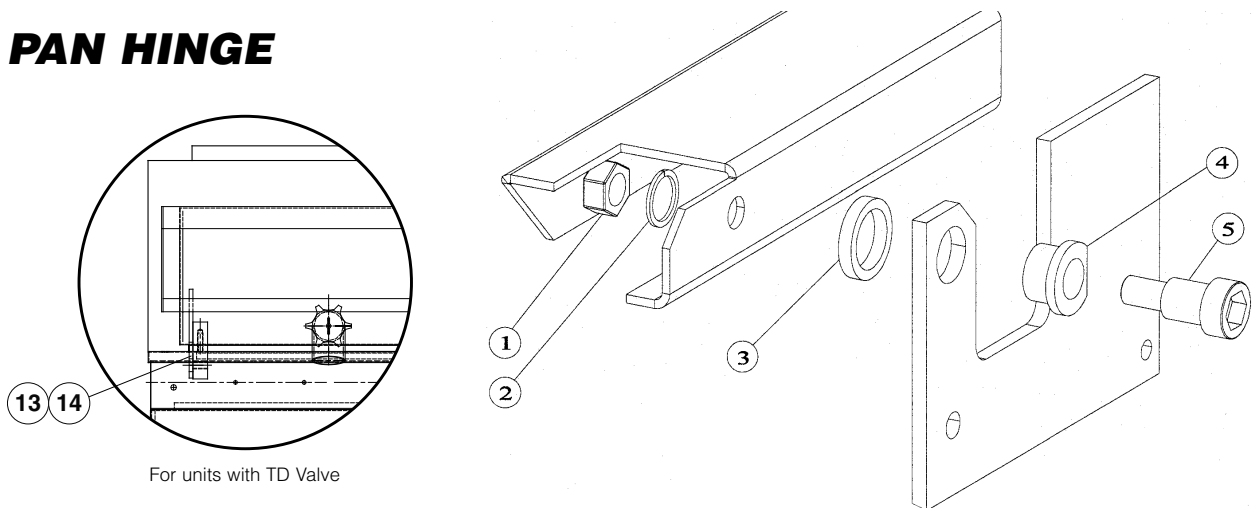

For units with TD Valve

ITEM NO.	PART NO.	DESCRIPTION	QTY.
1	FA20032	LOCK NUT 1/2-13 S.S.	2
2	FA30505-3	LOCK WASHER 1/2-13 S.S.	2
3	SK078248-1	SPACER	2
4	G02925-2	BUSHING	2
5	FA15015	BOLT 1/2-13 X 3/4", for units with TD	2
13	FA15019-2	SHOULDER BOLT, 1/2-13 (303)	2
14	SK50813	BEARING HINGE	2

FRAME / LID ASSMEBLY

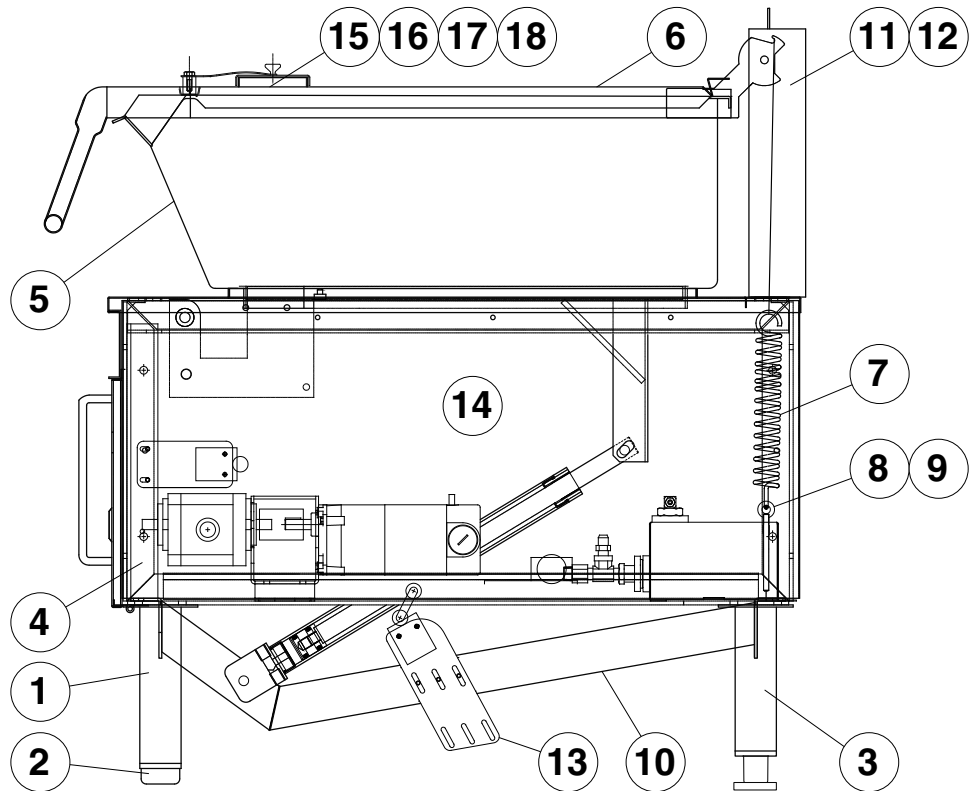

ITEM NO.	PART NO.	DESCRIPTION	QTY.
1.	SK2335499	LEG ASSEMBLY, FRONT	2
2.	SK078160-1	FEET, FRONT	2
3.	SK00414-1	LEG ASSEMBLY, REAR	2
4.	SK2335199	FRAME WELDMENT, 30 GAL.	1
	SK2335099	FRAME WELDMENT, 40 GAL.	1
5.	SK00343-1	PAN WELDMENT, SEL-30 (add -2 for units with TD)	1
	SK00344-1	PAN WELDMENT, SEL-40 (add -2 for units with TD)	1
6.	SK24571-1	LID, 30 GAL.	1
	SK24571-2	LID, 40 GAL.	1
7.	SK2452300	SPRING	2
8.	KE003686	HOOK WELDMENT	2
9.	SK23724-1	HOOK	2
10.	SK2337499	ACTUATOR MOUNTING BRACKET	1
	SK00352	ACTUATOR MOUNTING BRACKET, for units with TD	1
11.	KE003605-1	BACKGUARD ASSEMBLY, 30 GAL.	1
	KE003605	BACKGUARD ASSEMBLY, 40 GAL.	1
12.	SK2389300	BACKGUARD BACK, 30 GAL.	1
	SK2389301	BACKGUARD BACK, 40 GAL.	1
13.	KE002206	LIMIT SWITCH BRACKET	1
	KE002199	LIMIT SWITCH BRACKET, for units with TD	1
14.	SK2336800	SIDE PANEL, SEL/SGL	2
	SK2336801	SIDE PANEL, SEM/SGM	2
15.	SK00054	VENT COVER ASSEMBLY	1
16.	SK2211200	SPACER	1
17.	FA95081-1	BOLT, MODIFIED	1
18.	SK50179	WASHER	1

ELECTRICAL BOX

POWER TILT

MAMUAL TILT

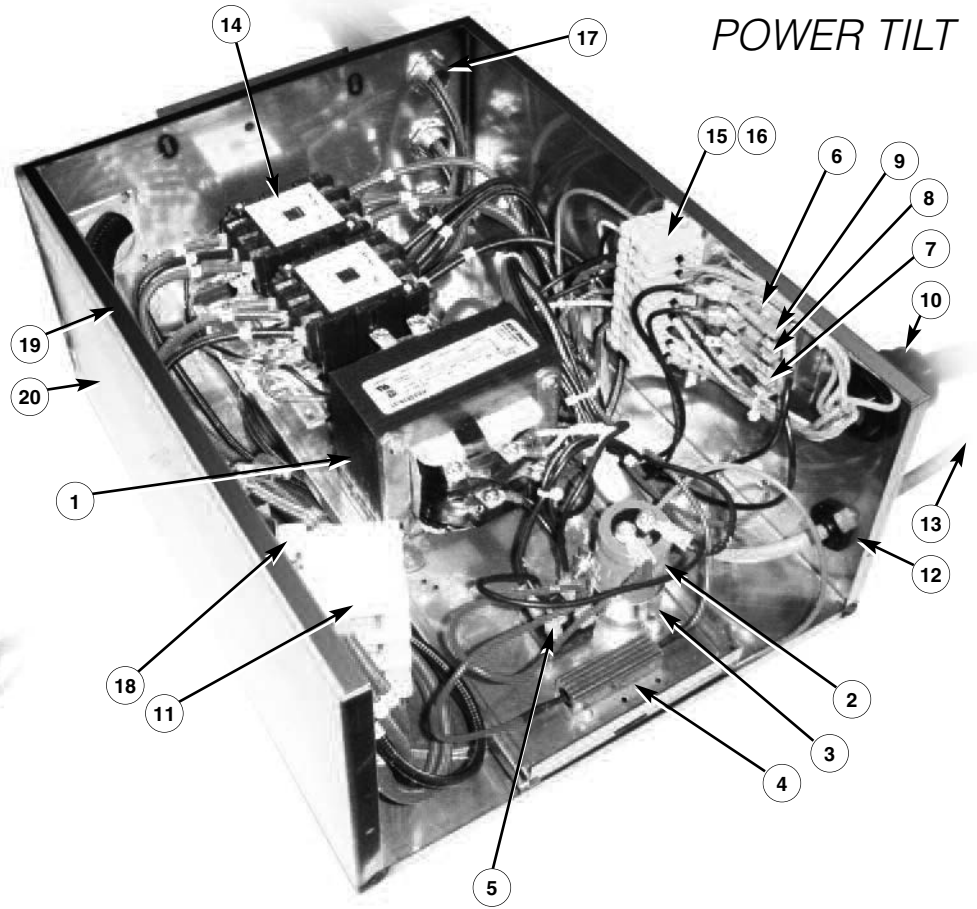

ITEM NO.	PART NO.	DESCRIPTION	QTY.
1	KE53838-31	TRANSFORMER - POWER TILT, 208 - 480V	1
	KE53838-30	TRANSFORMER - POWER TILT, 220 - 415V	1
	KE53838-33	TRANSFORMER - HAND TILT, 208 - 480V	1
	KE53838-15	TRANSFORMER - HAND TILT, 220 - 415V	1
2	SK1427305	CAPACITOR - POWER TILT	1
3	SK2282100	CAPACITOR CLAMP - POWER TILT	1
4	SK1426600	RESISTOR - POWER TILT	1
5	KE50581	RECTIFIER - POWER TILT	1
6	SK2320702	FUSE HOLDER	1
7	KE52936-10	FUSE 1.5A/250V - POWER TILT, 208 - 240V	1
	KE52936-11	FUSE 0.5A/250V - HAND TILT, 208 - 240V	1
8	KE52936-13	FUSE 1A AGC - POWER & HAND TILT	1
9	KE52936-9	FUSE 15A MDA - POWER TILT ONLY	1
10	SK2147403	LIQUID-TIGHT FITTING 5/8"	1
11	KE50377	TERMINAL BLOCK	3
	KE50376	TERMINAL END	1
12	SK2147401	LIQUID-TIGHT FITTING 5/16"	1
13	KE002226	INTERRUPTER SWITCH	1
14	KE603902-7	CONTACTOR 3 POLE	2
15	SK50872-1	TERMINAL BLOCK - JUNCTION	16
16	SK50872-2	TERMINAL END	2
17	SK50399	1/2" LIQUID-TIGHT CONNECTOR STRAIGHT	3
18	SK2347300	TERMINAL BLOCK SUPPORT	1
19	SK2383400	COVER GASKET	1
20	SK2372099	SERVICE BOX ASSY.	1

PAN

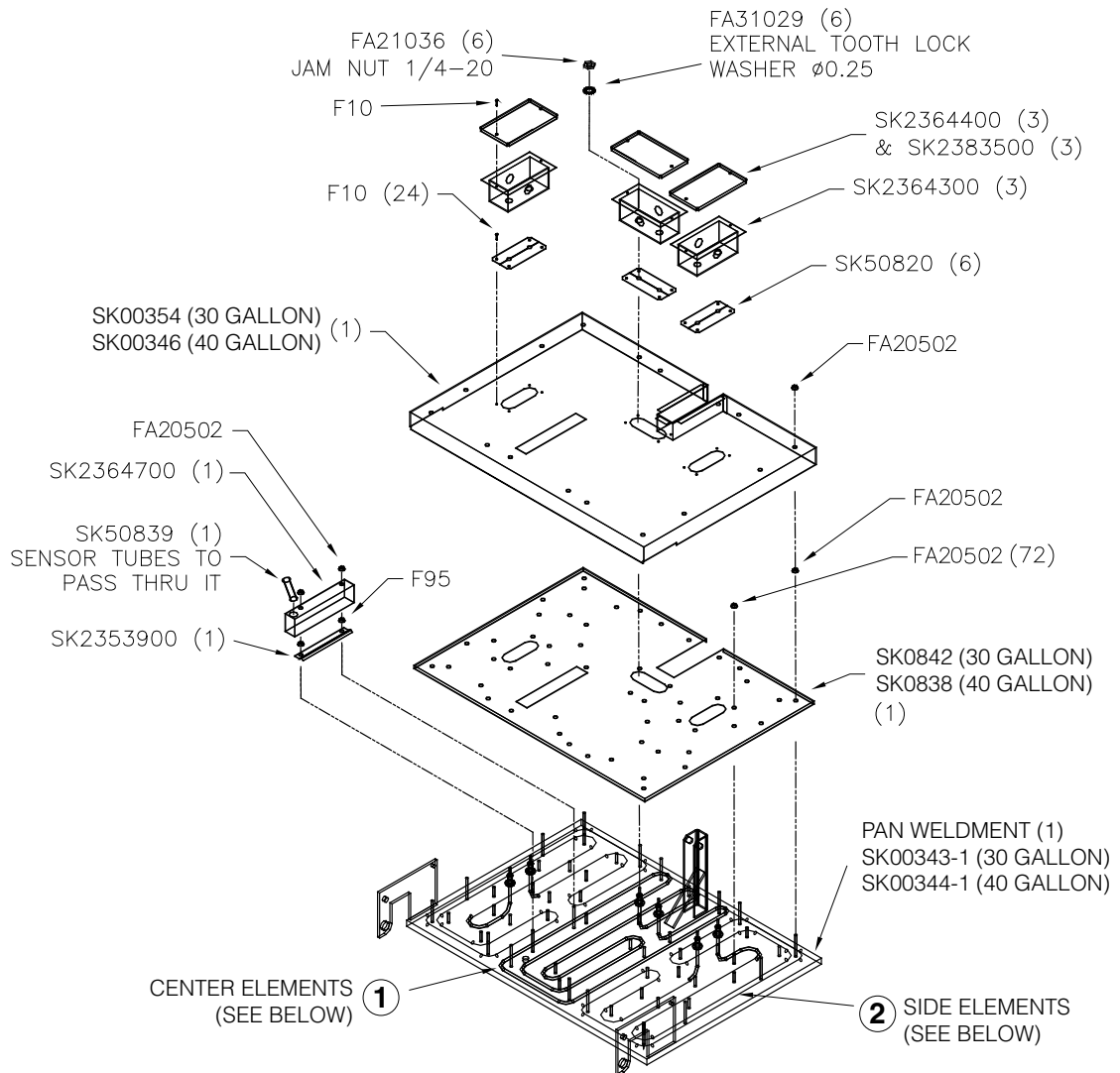

ITEM NO.	PART NO.	DESCRIPTION	QTY.
1. (SEL/SEM-30-TR)	2356306	ELEMENT - CENTER, 4.8KW, 600V.	1
	2356305	ELEMENT - CENTER, 4.8KW, 480V.	1
	2356304	ELEMENT - CENTER, 4.8KW, 415V.	1
	2356303	ELEMENT - CENTER, 4.8KW, 380V.	1
	2356302	ELEMENT - CENTER, 4.8KW, 240V.	1
	2356301	ELEMENT - CENTER, 4.8KW, 220V.	1
2. (SEL/SEM-30-TR)	2373006	ELEMENT - SIDE, 4.8KW, 600V.	2
	2373005	ELEMENT - SIDE, 4.8KW, 480V.	2
	2373004	ELEMENT - SIDE, 4.8KW, 415V.	2
	2373003	ELEMENT - SIDE, 4.8KW, 380V.	2
	2373002	ELEMENT - SIDE, 4.8KW, 240V.	2
	2373001	ELEMENT - SIDE, 4.8KW, 220V.	2
1. (SEL/SEM-40-TR)	2356206	ELEMENT - CENTER, 6KW, 600V.	1
	2356205	ELEMENT - CENTER, 6KW, 480V.	1
	2356204	ELEMENT - CENTER, 6KW, 415V.	1
	2356203	ELEMENT - CENTER, 6KW, 380V.	1
	2356202	ELEMENT - CENTER, 6KW, 240V.	1
	2356201	ELEMENT - CENTER, 6KW, 220V.	1
2. (SEL/SEM-40-TR)	2372906	ELEMENT - SIDE, 6KW, 600V.	2
	2372905	ELEMENT - SIDE, 6KW, 480V.	2
	2372904	ELEMENT - SIDE, 6KW, 415V.	2
	2372903	ELEMENT - SIDE, 6KW, 380V.	2
	2372902	ELEMENT - SIDE, 6KW, 240V.	2
	2372901	ELEMENT - SIDE, 6KW, 220V.	2
2372900	ELEMENT - SIDE, 6KW, 208V.	2	

WIRING DIAGRAM

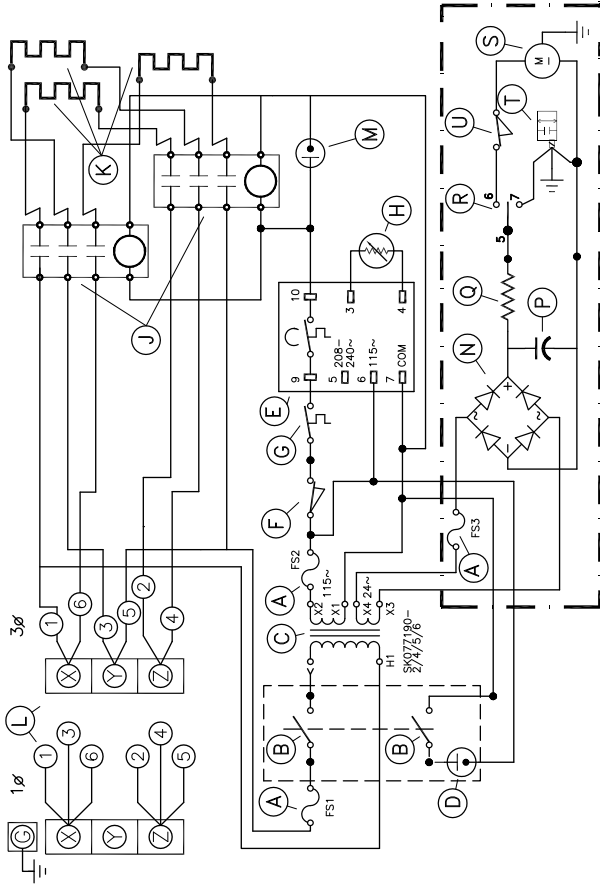

- A-FUSE
- B-POWER SWITCH
- C-TRANSFORMER
- D-PILOT-RED
- E-ELECTRONIC THERMOSTAT
- F-INTERRUPTER SWITCH
- G-HIGH LIMIT SWITCH
- H-RTD SENSOR
- J-CONTACTOR
- K-ELEMENT
- L-TERMINAL BLOCK
- M-PILOT-YELLOW
- N-RECTIFIER
- P-CAPACITOR
- Q-RESISTOR
- R-TILT CONTROL
- S-MOTOR
- T-DUMPING VALVE
- U-LIMIT SWITCH
- POWER TILT ONLY

- A-FUSIBLE
- B-COMMUTATEUR DE POUVOIR
- C-TRANSFORMATEUR
- D-VEILLEUSE-ROUGE
- E-THERMOSTAT ELECTRONIQUE
- F-INTERRUPTEUR DE POUVOIR
- G-COMMUTATEUR DE SECURITE
- H-CAPTEUR DE RTD
- J-CONTACTEUR
- K-ELEMENT
- L-BLOC D'ALIMENTATION
- M-VEILLEUSE-JAUNE
- N-RECTIFICATEUR
- P-CONDENSATEUR
- Q-RESISTANCE
- R-COMMUTATEUR DIRECTIONNEL
- S-MOTEUR
- T-DECHARGER SOUPE
- U-COMMUTATEUR DE LIMITE
- INCLINER D'ALIMENTATION SEULEMENT

CAUTION: REPLACE WITH SAME TYPE FUSES ATTENTION: REPLACER PAR UN FUSIBLE DU MEME TYPE		
MODELS/MODELES	POWER TILT/BASCULANT AUTO	HAND TILT/BASCULANT MANUEL
FS3	FS3	FS3
15A MDA	15A MDA	NOT USED/INUTILISE
FS2	FS2	FS2
1A AGC	1A AGC	1A AGC
FS1	FS1	FS1
1.5A MDL 110-240V MODELS ONLY MODELES SEULEMENT	1.5A MDL 110-240V MODELS ONLY MODELES SEULEMENT	.5A AGC 110-240V MODELS ONLY MODELES SEULEMENT

220/380,240/415V 3N~
F30,40E-L,MR/SEL,M-30,40-TR
SK90123-2H

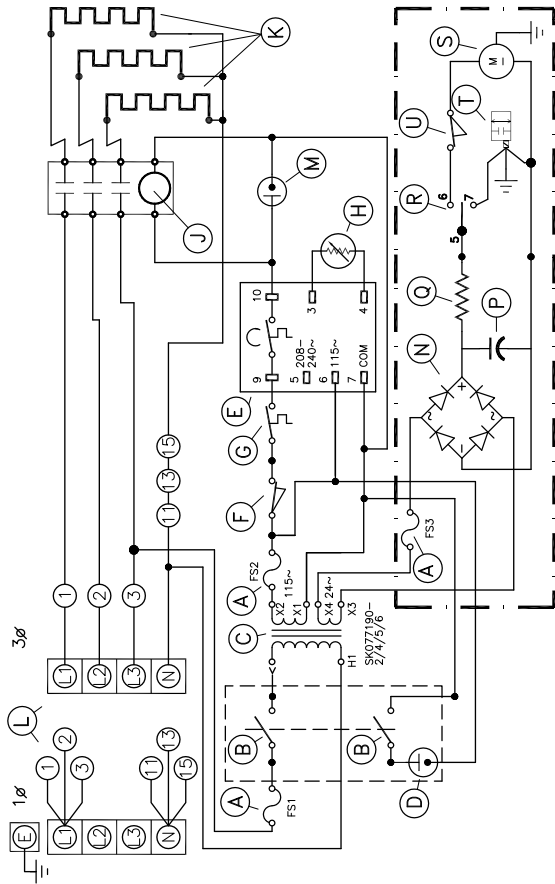

- A-FUSE
- B-POWER SWITCH
- C-TRANSFORMER
- D-PILOT-RED
- E-ELECTRONIC THERMOSTAT
- F-INTERRUPTER SWITCH
- G-HIGH LIMIT SWITCH
- H-RTD SENSOR
- J-CONTACTOR
- K-ELEMENT
- L-TERMINAL BLOCK
- M-PILOT-YELLOW
- N-RECTIFIER
- P-CAPACITOR
- Q-RESISTOR
- R-TILT CONTROL
- S-MOTOR
- T-DUMPING VALVE
- U-LIMIT SWITCH
- POWER TILT ONLY

- A-FUSIBLE
- B-COMMUTATEUR DE POUVOIR
- C-TRANSFORMATEUR
- D-VEILLEUSE-ROUGE
- E-THERMOSTAT ELECTRONIQUE
- F-INTERRUPTEUR DE POUVOIR
- G-COMMUTATEUR DE SECURITE
- H-CAPTEUR DE RTD
- J-CONTACTEUR
- K-ELEMENT
- L-BLOC D'ALIMENTATION
- M-VEILLEUSE-JAUNE
- N-RECTIFICATEUR
- P-CONDENSATEUR
- Q-RESISTANCE
- R-COMMUTATEUR DIRECTIONNEL
- S-MOTEUR
- T-DECHARGER SOUPE
- U-COMMUTATEUR DE LIMITE
- INCLINER D'ALIMENTATION SEULEMENT

CAUTION: REPLACE WITH SAME TYPE FUSES ATTENTION: REPLACER PAR UN FUSIBLE DU MEME TYPE		
MODELS/MODELES	POWER TILT/BASCULANT AUTO	HAND TILT/BASCULANT MANUEL
FS3	FS3	FS3
15A MDA	15A MDA	NOT USED/INUTILISE
FS2	FS2	FS2
1A AGC	1A AGC	1A AGC
FS1	FS1	FS1
1.5A MDL 110-240V MODELS ONLY MODELES SEULEMENT	1.5A MDL 110-240V MODELS ONLY MODELES SEULEMENT	.5A AGC 110-240V MODELS ONLY MODELES SEULEMENT

220/380,240/415V 3N~
F30,40E-L,MR/SEL,M-30,40-TR
SK90123-1H