

JET SPRAY

LT1

OWNER'S MANUAL/PARTS LIST

Instant Liquid Iced Tea Dispenser

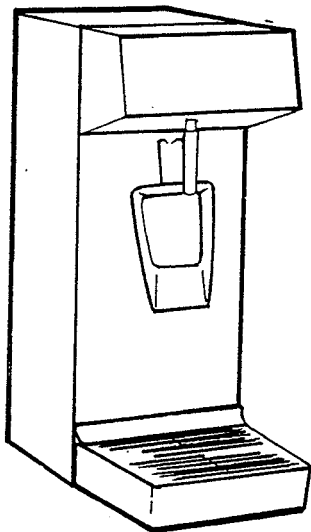

MODEL
LT1
LT1-W16
LT1-W25

This manual applies to models of
Serial Number 314936 or higher.

Manufactured by Jet Spray Corporation
825 University Avenue, P.O. Box 8250, Norwood, MA 02062

December 1994
Printed in the USA

Document No. 11341
Revision No. 20

Your Standard of Excellence for Beverage Merchandising on Six Continents

MODEL LT1

Instant Liquid Iced Tea Dispenser

The Model LT1 is intended for commercial use. It is a compact, lightweight, countertop unit designed to dispense a mixture of tea concentrate and water simply by activating a push handle. The proper electrical outlet, one gallon of tea concentrate, and a water source are all that is required to set the dispenser into operation.

BRIEF DESCRIPTION OF HOW THE UNIT WORKS

A water line is connected to the solenoid valve through a fitting located on the rear panel of the unit. A one gallon container of tea concentrate is placed inside the unit through the removable front panel. A product tube is placed inside the gallon container of tea concentrate, and runs up to the mixing block. When the push handle is depressed it closes a switch, activating the solenoid valve, allowing water to pass through the mixing block. The pressure drop in the mixing valve allows syrup to be siphoned from its container, mixed with water, and dispensed out the outlet tube.

A. INSTALLATION INSTRUCTIONS:

1. Place dispenser on a flat, sturdy surface accessible to a 115 volt 60Hz* outlet and a 30-125 psi water supply. It is recommended that a shutoff and an 80/100 mesh strainer be installed in the water line.
2. Do not plug in the unit.
3. Place flare gasket in check valve and connect to water inlet at rear of unit. (See instruction sheet included with check valve.) Connect a 1/4" OD copper water line to the fitting on the check valve and to a 30-125 psig water supply. Water line should be long enough so that unit can be moved for cleaning.
4. Remove drip tray and grille.
5. Remove front panel assembly from unit by lifting up and pulling out from the bottom. (See sketch.)



*EXPORT MODEL LT1-W25 REQUIRES A 220/240V 50HZ OUTLET

6. Remove cap and product tube assembly from inside unit. Place cap and product tube in a full gallon of concentrate. Slide container of concentrate into unit making sure that the plastic line from the product tube assembly is not crimped in any way.
7. Replace front panel assembly.
8. Replace drip tray and grille.
9. Plug power cord into 115 volt 60Hz* outlet.
10. Turn on power switch, located on rear of unit.
11. Depress push handle to prime unit.
NOTE: Draw approximately 12 oz. until product line is full.
12. Unit is now set for operation.

*EXPORT MODEL LT1-W25 REQUIRES A 220/240V 50HZ OUTLET

B. RATIO CONTROL - CONCENTRATE TO WATER

1. The ratio of concentrate to water is factory set for a 5 to 1 mix.
2. To adjust this ratio for a richer or weaker drink, use the 1/8" Allen wrench packed in the drip tray. Adjustments are made through a hole located in the upper right hand side panel. Using the 1/8" Allen wrench, turn the adjusting screw counterclockwise for a richer drink and clockwise for a weaker drink.

C. CLEANING UNIT

1. Drip tray, grille, and product tube assembly may be washed in warm soapy water, such as Joy. Rinse thoroughly in potable water.
2. Clean the outside of the dispenser with a clean damp cloth and mild soap.

D. CLEANING MIXING VALVE

1. Fill a clean one gallon container with warm water (70°F-100°F) and two ounces of cleaning solution, such as Joy.
2. Reconnect product tube assembly to mixing valve. Place other end of product tube assembly in cleaning solution.
3. Follow Installation Instructions #7 through #10. Activate push handle for three to four minutes.
4. Replace cleaning solution with one gallon of potable water. Rinse valve assembly.

E. SANITIZING DISPENSER

Using a clean one gallon container mix 1/2 teaspoonful (100 parts/million) of approved powdered chlorine sanitizer* with four quarts of water. Depress push handle until all the sanitizing solution has been used.

*Diversey Wyandotte Multi-Chlor or Equivalent Powder or Liquid Sanitizer

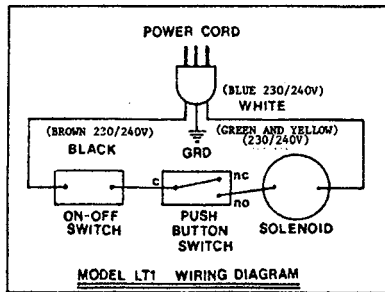



IMI CORNELIUS INC.
One Cornelius Place
Anoka, MN. 55303-6234
Telephone 1-800-238-3600
Facsimile 1-800-258-0255

www.cornelius.com

ILLUSTRATED PARTS LIST

LT-1 COLD BEVERAGE DISPENSER

MODEL NO.

A1371

A1456

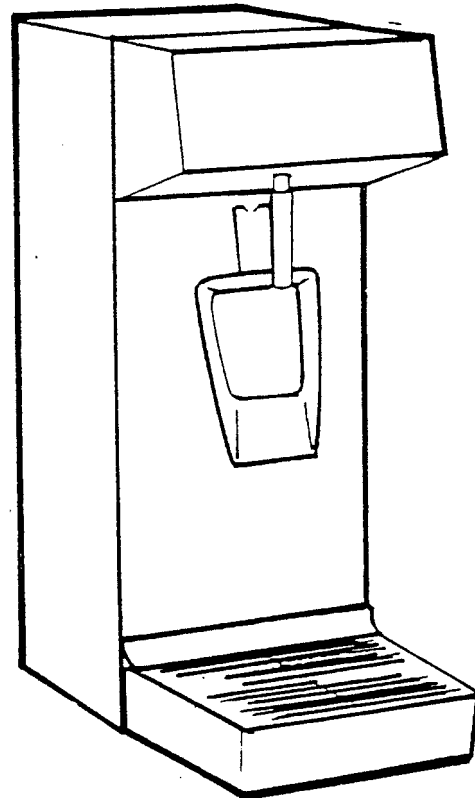



IMI CORNELIUS INC.
One Cornelius Place
Anoka, MN. 55303-6234
Telephone 1-800-238-3600
Facsimile 1-800-258-0255

www.cornelius.com

ILLUSTRATED PARTS LIST

LT-1 COLD BEVERAGE DISPENSER

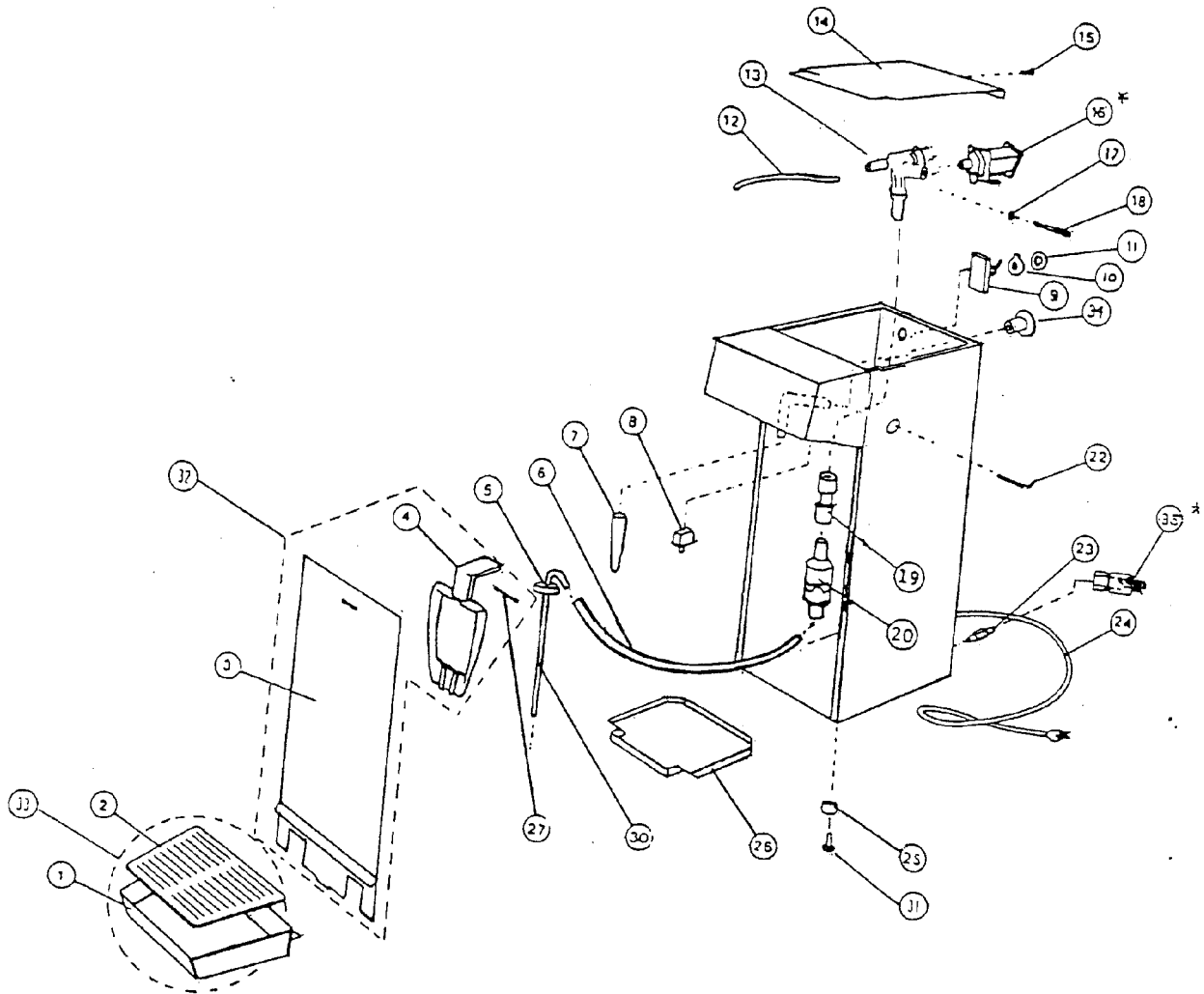

FIGURE 1. GENERAL ASSEMBLY



IMI CORNELIUS INC.
 One Cornelius Place
 Anoka, MN. 55303-6234
 Telephone 1-800-238-3600
 Facsimile 1-800-258-0255

www.cornelius.com

ILLUSTRATED PARTS LIST

LT-1 COLD BEVERAGE DISPENSER

Item No.	Part No.	Name
1	18805001	Drip Tray (Serial No. 314936 and Above)
	A1500	Drip Tray (Serial No. 3149356 and Below)
2	18805002	Cup Rest (Serial No. 314936 and Above)
3	18786	Panel Fnt Asy (Serial No. 314936 and Above)
	A3506	Panel Fnt Asy (Serial No. 14380-314935)
	A1333	Panel Fnt Asy (Serial No. 14380 and Below)
4	A3507	Push Handle (Serial No. 14380 and Above)
	A1506	Push Handle (Serial No. 14379 and Below)
5	A1834	Cap
6	A1365	Tube Protector Product
7	A1340	Spout Extension
8	S8214	Switch Wtr Push Btn
9	A5186	Switch Rocker (Serial No. 22622 and Above)
	S3004	Switch Toggle (Serial No. 22621 and Below)
10	S3837	Plate Switch
11	S1675	Nut Knurled Ring
12	A1364	Outlet Tube
13	A1909	Block Mixing
14	S9178	Cover Top Panel
15	A1386	Screw Panel (Pack of 4)
16	A1339	Solenoid Valve Asy 120V 60HZ
	A1430	Solenoid Valve Asy 220/240V 60HZ

Item No.	Part No.	Name
17	S3746	Ring (Pack of 12)
18	S5624	Screw and O-Ring Adjust
19	A2161	Conn Check Valve Union
20	A2557	Valve Chk Inline
21		Item Not Used
22	S4159	Tool Wrench Allen
23	A1724	Fitg Inlet Water
24	S1249	Cord Serv
25	S6778	Foot
26	A1360	Drip Tray
27	A1505	Pin Cotter
28		Item Not Used
29		Item Not Used
30	S9526	Tube S.S.
31	S6410	Screw (Pack of 4)
32	A8807	Panel Fnt Asy (Serial No. 314936 and Above; No Longer Available)
	A1333	Panel Fnt Asy (Serial No. 314935 and Below)
33	18805	Drip Tray Ass'y (Serial No. 314936 and Above; No Longer Available, Order 18805001 and 18805002)
	A1503	Drip Tray Ass'y (Serial No. 314935 and Below)
34	A1900	Restrictor Plug
35	A5601	Valve Chk Ball Single
	S6783	Valve Chk Kit Ball, Double