

Hot Cabinet	<b>FL-1917-KFC-M</b>
Rev. 14 (10/08)	Page 1 of 16

**INSTALLATION, OPERATION and MAINTENANCE MANUAL**  
**for Cres Cor Models:**  
**CC-2222C-PR, CC-2222C-PL, CC-2222C-PRL,**  
**CC-2222C-PR-2, CC-2222C-PL-2, and CC-2222C-PRL-2**

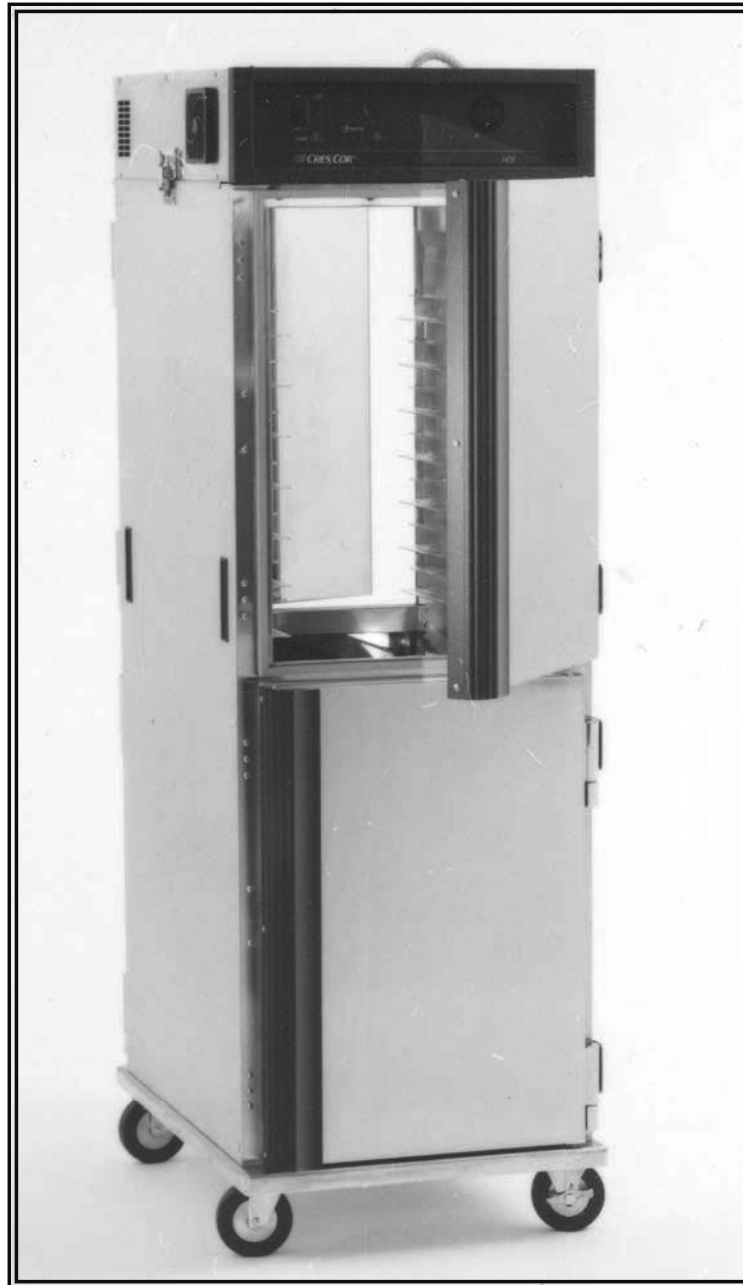

Hot Cabinet	<b>FL-1917-KFC-M</b>
Rev. 14 (10/08)	Page 2 of 16

## TABLE OF CONTENTS

<b>SUBJECT</b>	<b>PAGE</b>
INSTALLATION INSTRUCTIONS.....	3
OPERATING INSTRUCTIONS.....	4
MAINTENANCE INSTRUCTIONS	
How to Clean the Unit.....	5
Maintenance.....	6, 7
Latch Adjustment.....	6
Trouble Shooting Guide.....	7
Replacement Parts (Cabinet).....	8, 9, 10, 11
Replacement Parts (Hot Unit).....	12, 13, 14
Wiring Diagrams.....	15, 16
ELECTRICAL DATA SHEET.....	FL-1484-A
SERVICE POLICY and AGENCY LIST.....	FL-1400



## INSTALLATION INSTRUCTIONS

### GENERAL SPECIFICATIONS:

Net Weight: 355 Lbx. (Includes Hot Cabinet)  
 Dimensions: 24-15/16" W x 33-15/16" D x 77" H  
 Casters: 5" Dia. Swivel-type (All 4 casters equipped with brakes.)  
 Capacity: Fifteen (15) 18" x 26" pans on 3-5/8" spacing.

### ELECTRICAL SPECIFICATIONS:

Model No.	Hot Unit	Volts	Watts	Amps	Phase	Cycle	Service
CC-2222C-PR CC-2222C-PL CC-2222C-PRL	HU18-671-44-G	120	2000	18	1	60 Hz.	AC
CC-2222C-PR-2 CC-2222C-PL-2 CC-2222C-PRL-2	HU18-671-45-G	240	2000	9	1	60 Hz.	AC

### INSTALLATION OF OPTIONAL TWIST-LOCK PLUG: (NEMA L5-20) P/N 0840-036



**Replacement of electrical components must be done by a qualified electrician.**

- Cut molded plug off end of power supply cord (Item 42).
- Remove cover from plug body by loosening three screws on face of plug.
- Strip jacket from cord approximately 1-1/2".
- Strip individual wires per strip gage found on rear of plug body.
- Slide plug cover over cord.
- Connect individual wires to plug body. Make sure color code is followed (i.e. green to green, white to white; colored to colored).
- Pull plug cover over plug body and fasten with screws on face of plug.
- Insure cord clamp on rear of plug is over cord jacket. Tighten cord clamp.

### FIELD-REVERSING CABINET DOORS:



**WHEN REVERSING CABINET DOORS, PROPER DOOR STOPS MUST BE INSTALLED ON ALL DOOR HINGES.**

See "Replacement Parts" page for Door Stop kits.

### INSTALLATION OF HOT UNIT:

- Place \*Hot Unit on top of cabinet. Make sure the ducts that extend out of the hot unit bottom go into the side ducts of the cabinet top.
- Latch hot unit to the cabinet on both sides.
- Plug power cord into proper wall outlet as follows:

HOT UNIT	Volts	Amps.	Ph.	Serv.	NEMA Ref.
HU-18-671-44-G	120	20	1	AC	5-20 R
HU-18-671-45-G	240	20	1	AC	6-15

(For wall outlet NEMA configuration, see FL-1484-A included in this manual.)

#### 4. Humidity Pan

- Make sure splash baffles are inside humidity pan (metal pan only).
- Fill pan one-half full with water.
- Slide pan into the angles located at the inside top of the cabinet.

\*Hot Unit is shipped separately because of the overall height.

Hot Cabinet	<b>FL-1917-KFC-M</b>
Rev. 14 (10/08)	Page 4 of 16

## OPERATION INSTRUCTIONS

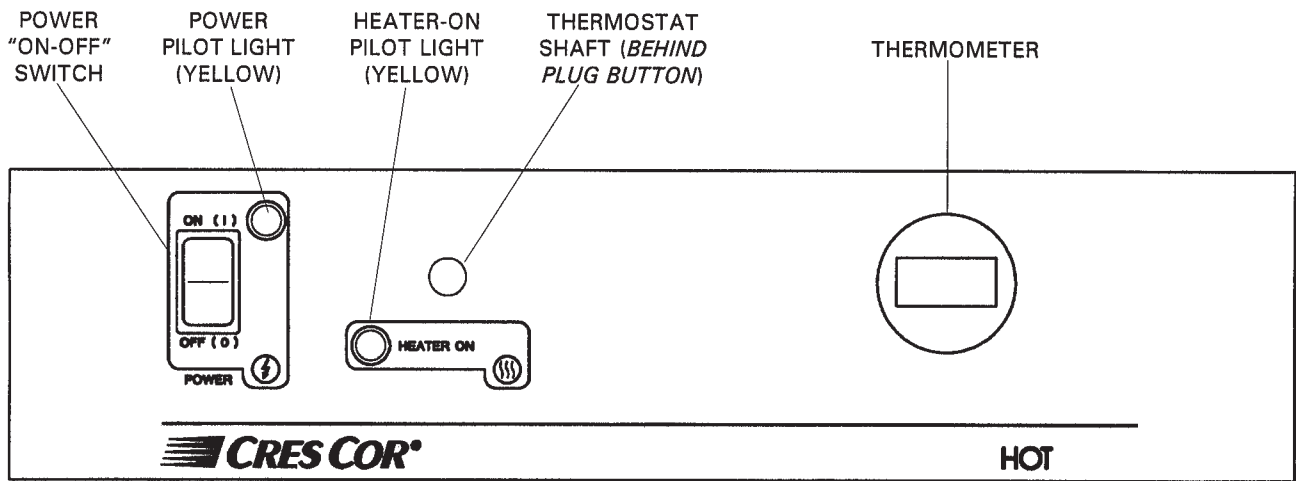

Figure 1: Control Panel

### HOW TO START UNIT:

1. Push the *POWER* switch to "ON". The *yellow* light will light up. Yellow heating light will light, showing that the heater is on.
2. Pre-heat cabinet for 45 minutes.
3. Put food into cabinet.



**CAUTION** Be sure pans are completely inside cabinet before closing the door. Do NOT use the door to push pans in; this will damage the door.

Be sure pans are completely inside cabinet before closing

**To Shut Unit Down: Push switch to "OFF".**

### TO ADJUST THE TEMPERATURE:

Thermostat is pre-set at 180°F in an empty cabinet.

1. Push switch to "ON".
2. Pull out plug button in the front of the Hot Unit.
3. Turn the thermostat shaft with screwdriver.
  - a. To increase (raise) the temperature, turn shaft clockwise.
  - b. To decrease (lower) the temperature, turn shaft counterclockwise.
4. Watch the thermometer. The actual temperature reading will be the average between the lowest and the highest as the numbers increase and decrease.
5. Snap in the plug button.

**NOTE:** The Digital Thermometer will flash if cabinet temperature is below 140°F/60°C or above 250°F/121°C.  
 Call the factory if you need different settings.

## HOW TO CLEAN THE UNIT:

 <b>CAUTION</b>	<b>1. ALLOW CABINET TO COOL.</b> <b>2. REMOVE HOT UNIT BEFORE CLEANING.</b>
--	--

- Wipe up spills as soon as possible.
- Clean regularly to avoid heavy dirt build-up.

### Cleaning Hints:

1. Use the mildest cleaning procedure that will do the job.
2. Always rub in the direction of the polish lines to avoid scratching the surface.
3. Use only a soft cloth, sponge, fibrous brushes, plastic or stainless steel pad for cleaning and scouring.
4. Rinse thoroughly with fresh water after every cleaning operation.
5. Always wipe dry to avoid water marks.

	SOIL	CLEANER	METHOD
<b>CABINET</b>  Inside and Outside (Stainless Steel)	ROUTINE CLEANING	Soap, Ammonia, or mild detergent* and water.	1. Sponge on with cloth. 2. Rinse with water. 3. Wipe dry.
	STUBBORN SPOTS AND STAINS	Mild abrasive made for stainless steel.	1. Apply with damp sponge or cloth. 2. Rub lightly.
	BURNT-ON FOODS OR GREASE	Chemical oven cleaner for stainless steel.	Follow oven cleaner manufacturer's directions.
	HARD WATER SPOTS and SCALE	Vinegar	1. Swab or wipe with cloth. 2. Rinse and dry.
<b>HOT UNIT, RACK INSERTS</b>  Side wall Air Duct and Humidity Pan (Aluminum)	DIRT	Mild detergent* & hot water, or mild abrasive cleaner.	1. Use soft, damp cloth. 2. Rinse with hot water. 3. Wipe dry.
		Steam (no strong alkaline additive)	1. Rinse after steam cleaning. 2. Wipe dry.
	FINGERPRINTS, GREASE, OIL.	Chemical oven cleaner; for Aluminum	Follow Oven Cleaner manufacturer's directions.
		Mild abrasive cleaner. Oily or waxy cleaner.	Apply with soft, clean cloth.
	WATER SPOTS.	Wipe with damp cloth. Mild abrasive cleaner.	

*\*Mild detergents include soaps and non-abrasive cleaners.*

Hot Cabinet	<b>FL-1917-KFC-M</b>
Rev. 14 (10/08)	Page 6 of 16

## MAINTENANCE



**VENT FAN FILTER MUST BE CLEANED DAILY.**

The filter is found on the left side of the Hot Unit. It snaps onto the fan.

Soak filter in soapy water and rinse with clean water.

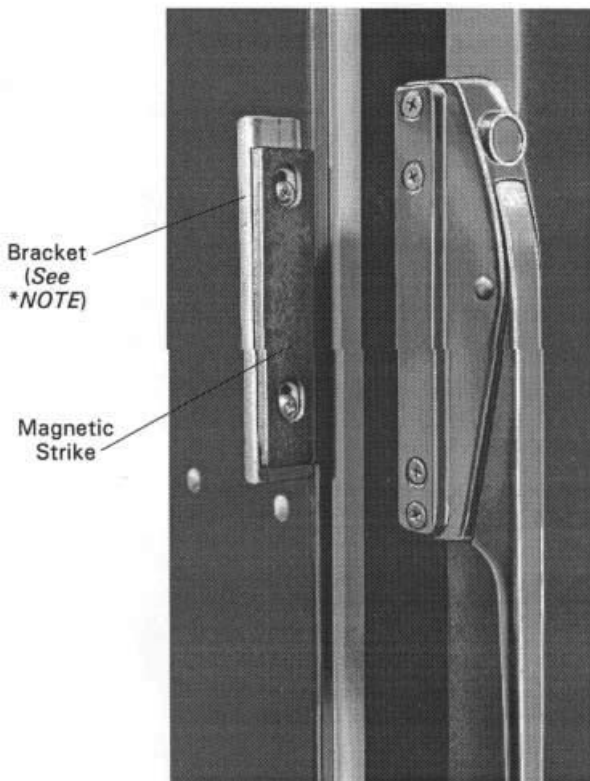
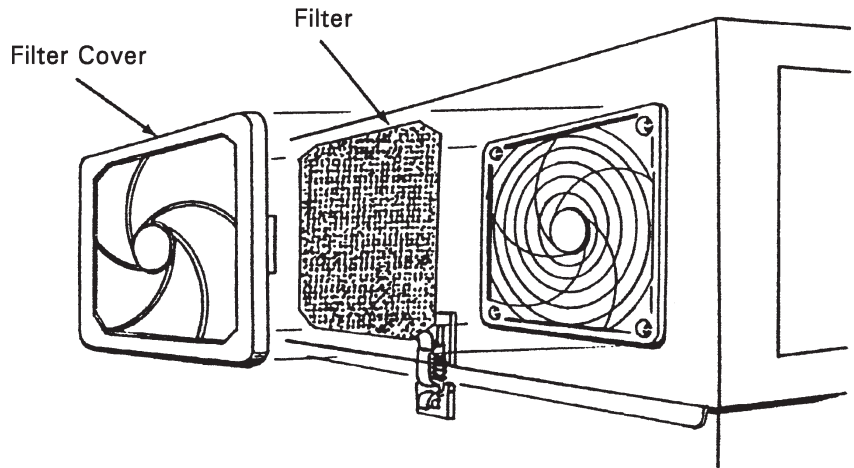

### HOW TO ADJUST THE DOOR LATCH: (Optional)

1. For vertical (up and down movement) adjustment:
  - a. Loosen (2) screws located in magnetic strike attached to bracket on cabinet (see \*NOTE).
  - b. Move strike up or down for alignment to magnet on latch.
  - c. Tighten screws to secure.
2. For horizontal adjustment (greater or lesser magnetic draw).
  - a. Loosen (4) screws in door latch.
  - b. Move latch forward or backward to adjust magnetism.
  - c. Tighten screws to secure.

**NOTE:** Bracket not used on 222B Series Cabinets.

## MAINTENANCE INSTRUCTIONS TROUBLE-SHOOTING GUIDE



**IF UNIT GETS TOO HOT OR WON'T SHUT OFF, DISCONNECT POWER AT BRANCH PANEL. DO NOT UNPLUG CORD!**

**If hot unit is *NOT* working, first check the following causes:**

- |  |  |
|--|--|
| 1. Cord is unplugged from wall outlet.           | 3. Switch is turned off.   |
| 2. Circuit breaker/fuse to wall outlet is blown. | 4. Thermostat is turned off, or is set too low.<br>(See “Thermostat Calibration”). |

If the four items above check out all right and the Hot Unit **STILL** doesn't work, one or more of the components listed under the problems below will have to be checked and replaced.

PROBLEM	POSSIBLE CAUSE
1. Cabinet does not heat, or doesn't heat properly	1a. Fuse 1b. Thermostat 1c. Heater 1d. Blower 1e. Hi-limit Switch 1f. On/Off Switch
2. Blowers do not operate	2a. On/Off Switch 2b. Fuse 2c. Blower Motor 2d. Thermostat
3. Heaters will not shut off	3a. Thermostat
4. Vent fan does not shut off	4a. Vent Fan Switch 4b. Control compartment is still hot.
5. Vent fans do not operate (See Note)	5a. Fuse 5b. Vent fan switch defective 5c. Vent fan defective

**NOTE:** Vent fans will not operate until the control compartment requires ventilation to limit temperatures.

Replacement of electrical components must be done by a qualified electrician. Refer to our *Service Agency list, FL-1400* (found in the back of this manual), of authorized service centers. Instructions for replacing parts are included in replacement parts list.

Hot Cabinet	<b>FL-1917-KFC-M</b>
Rev. 14 (10/08)	Page 8 of 16

**REPLACEMENT PARTS**  
**for CC-222C Cabinets (Manufactured from 4/00 to present)**  
*Include all information on nameplate when ordering parts*

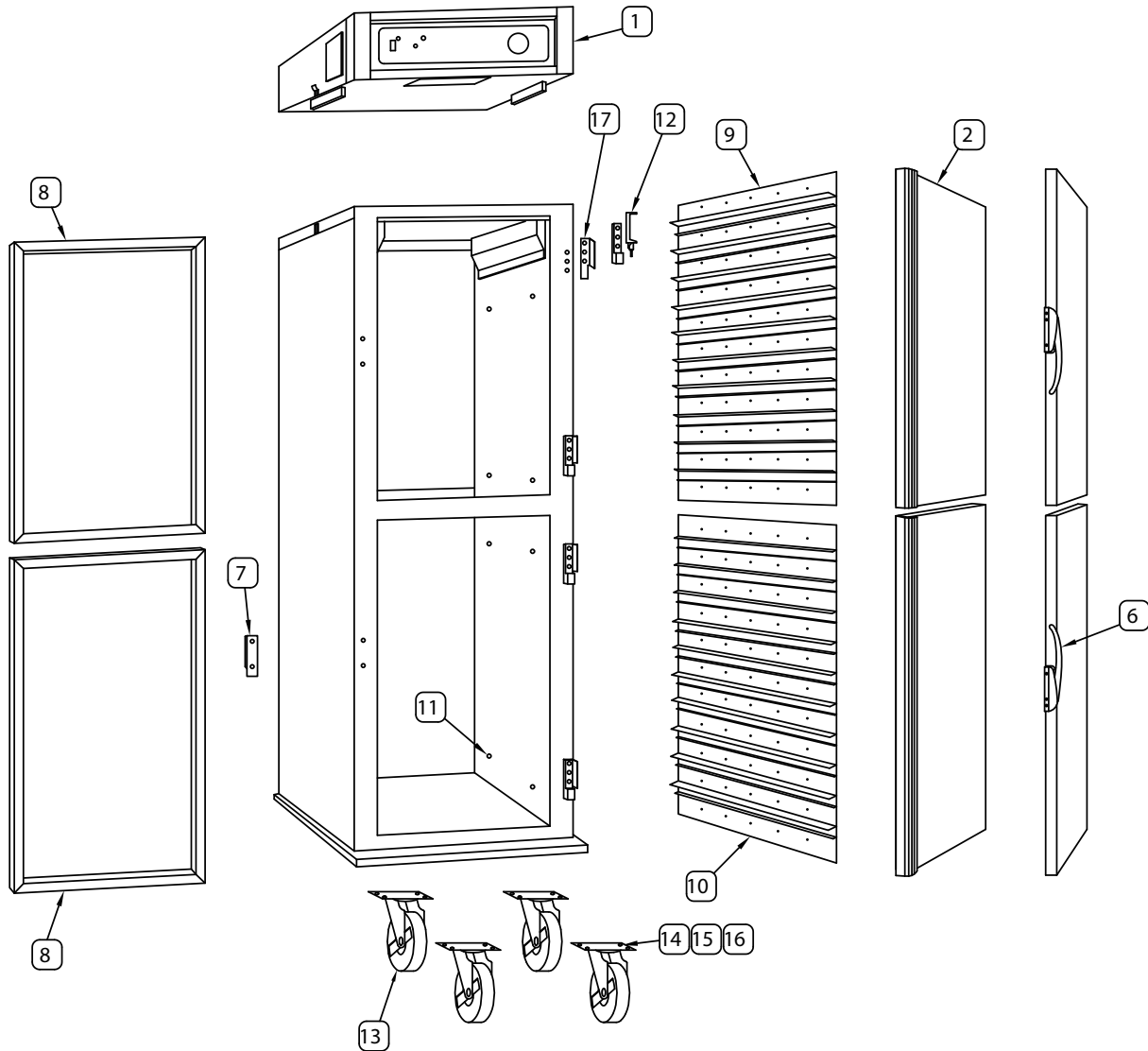

**REPLACEMENT PARTS for CC-2222 CABINETS (Manufactured from 4/00 to present)**

Item	DESCRIPTION	REQ'D	PART NUMBER	Item	DESCRIPTION	REQ'D	PART NUMBER
1	Hot Unit, Complete			10	Rack Insert, Lower	1	1103-097
	110-120 Volt	1	HU-18-671-44-G	11	Shoulder Screw	16	0567-236
	220-240 Volt	1	HU-18-374-45-G	12	Hinge Kit	4	0519-087-K
2	Door Kit	4	1221-455-K	13	Castors w/Brake	4	0569-306-B
	Door Kit w/full		1221-459-K	14	*Caster Screw	16	0567-103
	window (optional)			15	*Caster Lockwasher	16	0567-080
6	Latch & Strike Kit	4	1006-104-K1	16	*Caster Hex Nut	16	0567-062
8	Gasket Kit	4	0861-168	17	Door Stop Kit, RH		0553-706-K
9	Rack Insert, Upper	1	1103-096		Door Stop Kit, LG		0553-707-K

*\*Indicated but not shown.*



**REPLACEMENT PARTS**  
 for CC-2222B Cabinets (Manufactured from 10/97 thru 3/00)  
*Include all information on nameplate when ordering parts*

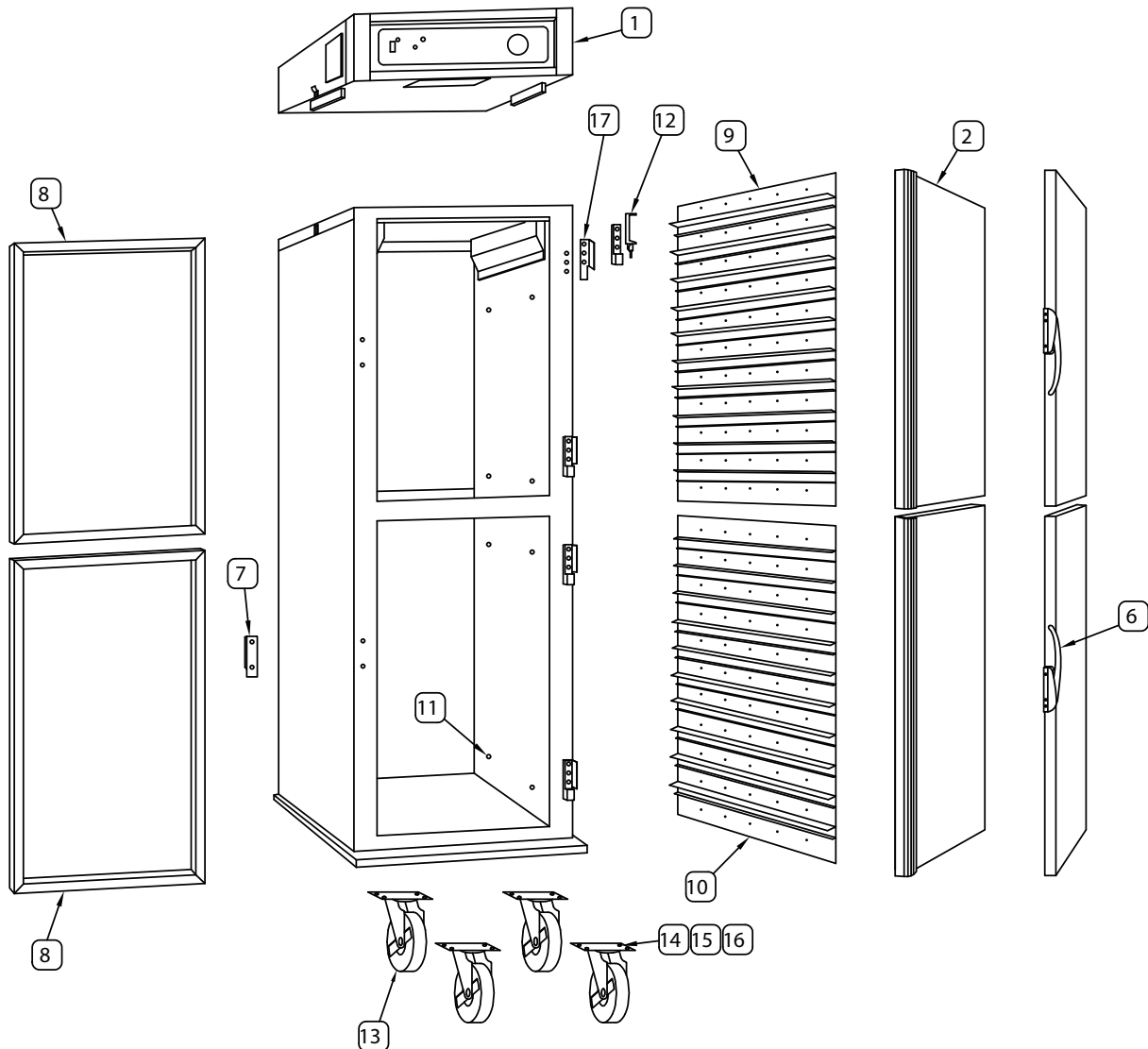

**REPLACEMENT PARTS for CC-2222B CABINETS (Manufactured from 10/97 to 3/00)**

Item	DESCRIPTION	REQ'D	PART NUMBER	Item	DESCRIPTION	REQ'D	PART NUMBER
**1	Hot Unit, Complete			11	Shoulder Screw	16	0567-236
	110-120 Volt	1	HU-18-671-44-G	12	Hinge Kit	4	0519-087-K
	220-240 Volt	1	HU-18-374-45-G	13	Casters w/Brake	4	0569-306-B
2	Door Kit	4	1221-455-K	14	*Caster Screw	16	0567-103
6	Latch & Strike Kit (optional)	4	1006-104-K1	15	*Caster Lockwasher	16	0567-080
8	Gasket Kit	4	0861-168	16	*Caster Hex Nut	16	0567-062
9	Rack Insert, Upper	1	1103-069	17	Door Stop Kit, RH		0553-706-K
10	Rack Insert, Lower	1	1103-070		Door Stop Kit, LG		0553-707-K

\*\* **Note:** When ordering replacement Hot Units, low-profile water pan 1017-076 is required.

\*Indicated but not shown.

Hot Cabinet	<b>FL-1917-KFC-M</b>
Rev. 14 (10/08)	Page 10 of 16

**REPLACEMENT PARTS**  
for CC-2222A Cabinets (Manufactured from 6/96 to 10/97)  
*Include all information on nameplate when ordering parts*

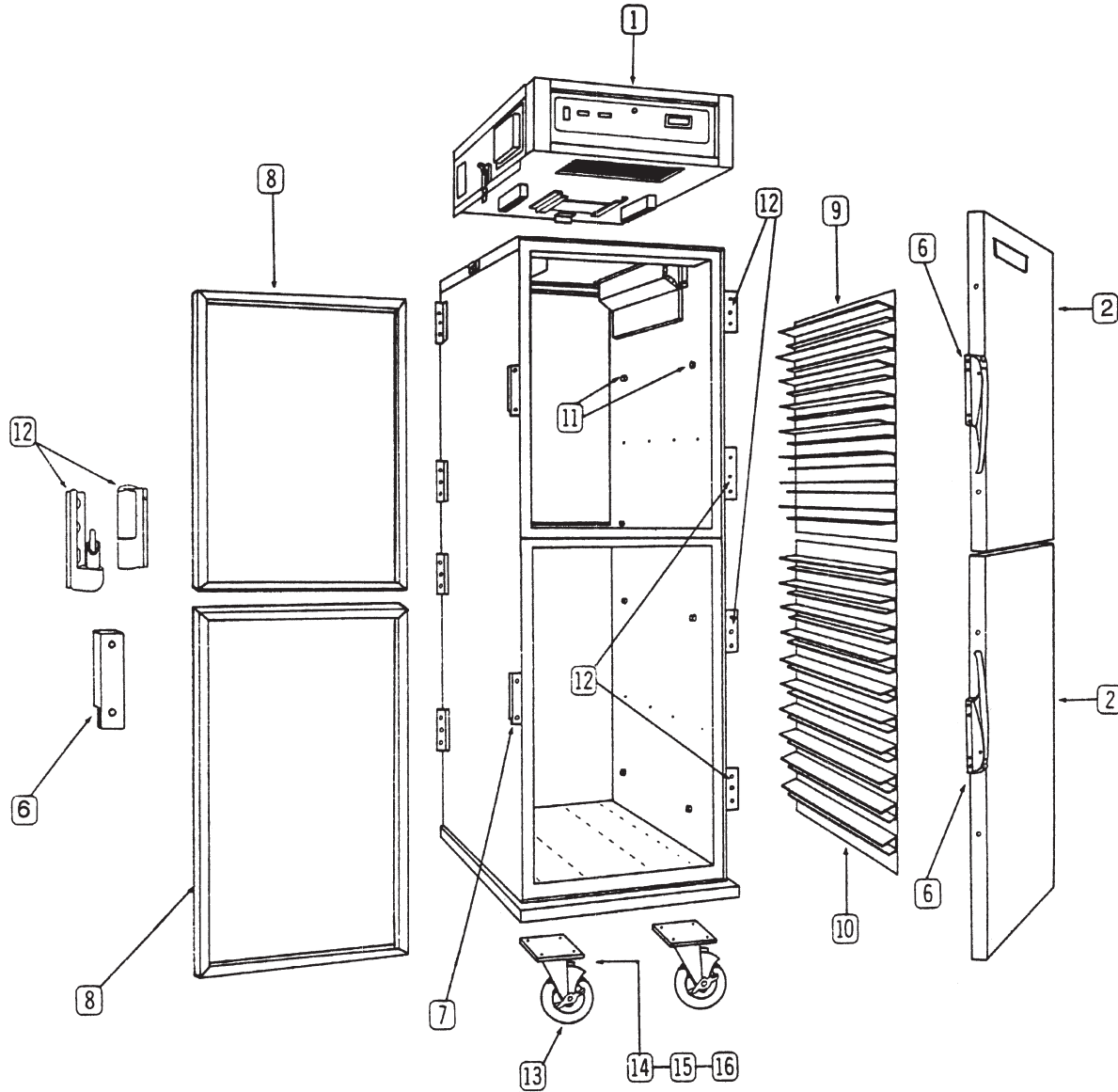

**REPLACEMENT PARTS for CC-2222A CABINETS (Manufactured from 6/96 to 10/97)**

Item	DESCRIPTION	REQ'D	PART NUMBER	Item	DESCRIPTION	REQ'D	PART NUMBER
1	Hot Unit, Complete			10	Rack Insert, Lower	1	1103-070
	110-120 Volt	1	HU-18-671-44-F	11	Shoulder Screw	16	0567-236
	220-240 Volt	1	HU-18-374-45-F	12	Hinge Kit	4	0519-087-K
2	Door Kit	4	1221-445-K	13	Castors w/Brake	4	0569-306-B
6	Latch & Strike Kit	4	1006-108-K2	14	*Caster Screw	16	0567-103
	(optional)			15	*Caster Lockwasher	16	0567-080
8	Gasket Kit	4	0861-168	16	*Caster Hex Nut	16	0567-062
9	Rack Insert, Upper	1	1103-069				

*\*Indicated but not shown.*

**REPLACEMENT PARTS**  
 for CC-2222 Cabinets (Manufactured thru 5/96)  
*Include all information on nameplate when ordering parts*

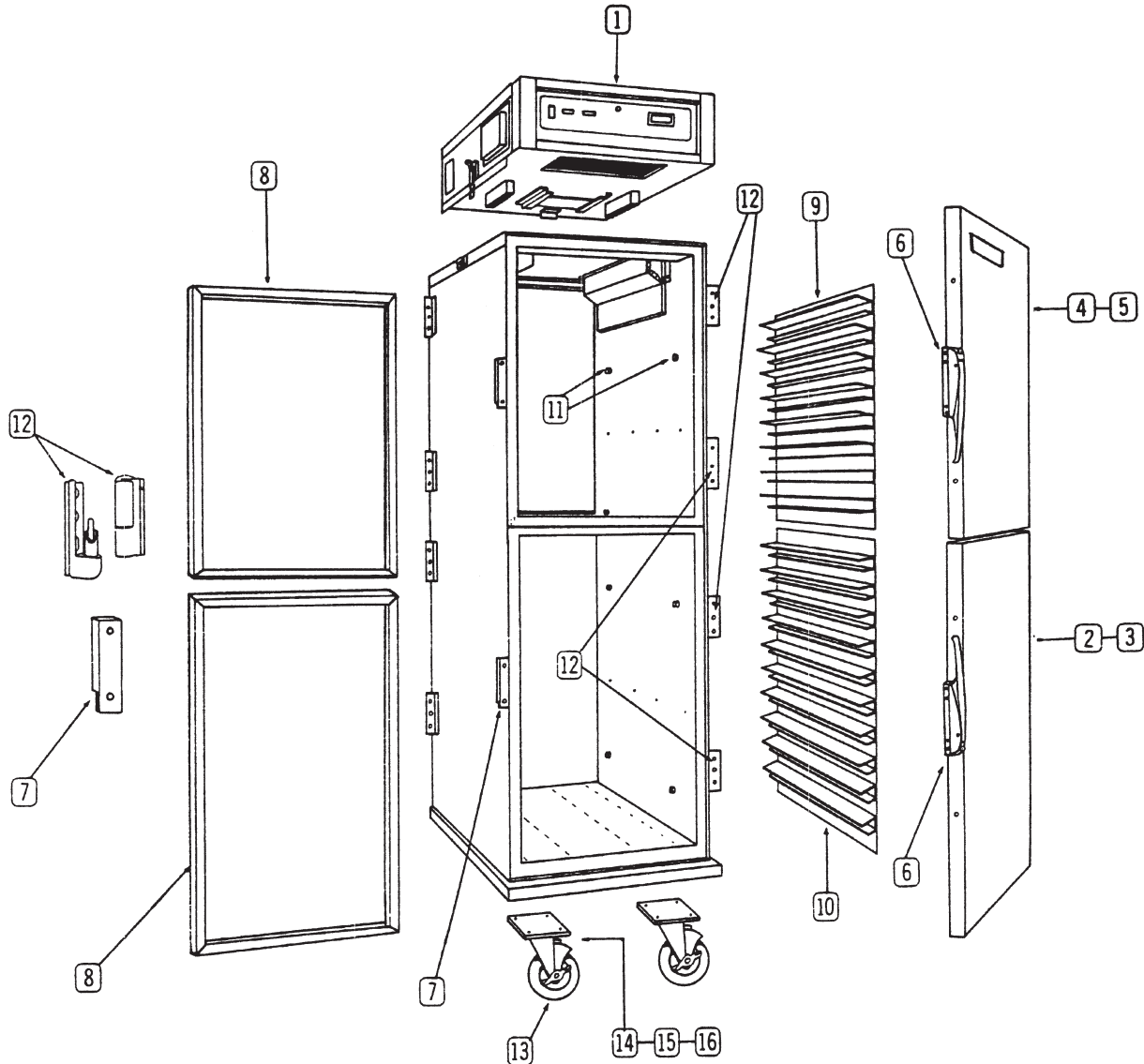

**REPLACEMENT PARTS for CC-2222 CABINETS (Manufactured thru 5/96)**

Item	DESCRIPTION	REQ'D	PART NUMBER	Item	DESCRIPTION	REQ'D	PART NUMBER
1	Hot Unit, Complete			8	Gasket Kit	4	0861-168
	110-120 Volt	1	HU-18-671-44-F	9	Rack Insert, Upper	1	1103-069
	220-240 Volt	1	HU-18-374-45-F	10	Rack Insert, Lower	1	1103-070
2	Lower Door Kit, RH	2	5508-047	11	Shoulder Screw	16	0567-236
3	Lower Door Kit, LH	2	5508-046	12	Hinge Kit	4	0519-079-K
4	Upper Door Kit, RH	2	5508-046	13	Casters w/Brake	4	0569-306-B
5	Upper Door Kit, LH	2	5508-047	14	*Caster Screw	16	0567-103
6 & 7	Latch & Strike Kit	4	1006-104-K1	15	*Caster Lockwasher	16	0567-080
				16	*Caster Hex Nut	16	0567-062

*\*Indicated but not shown.*

Hot Cabinet	<b>FL-1917-KFC-M</b>
Rev. 14 (10/08)	Page 12 of 16

**HOT UNIT REPLACEMENT PARTS**  
Manufactured from 3/00 to present)  
*Include all information on nameplate when ordering parts*

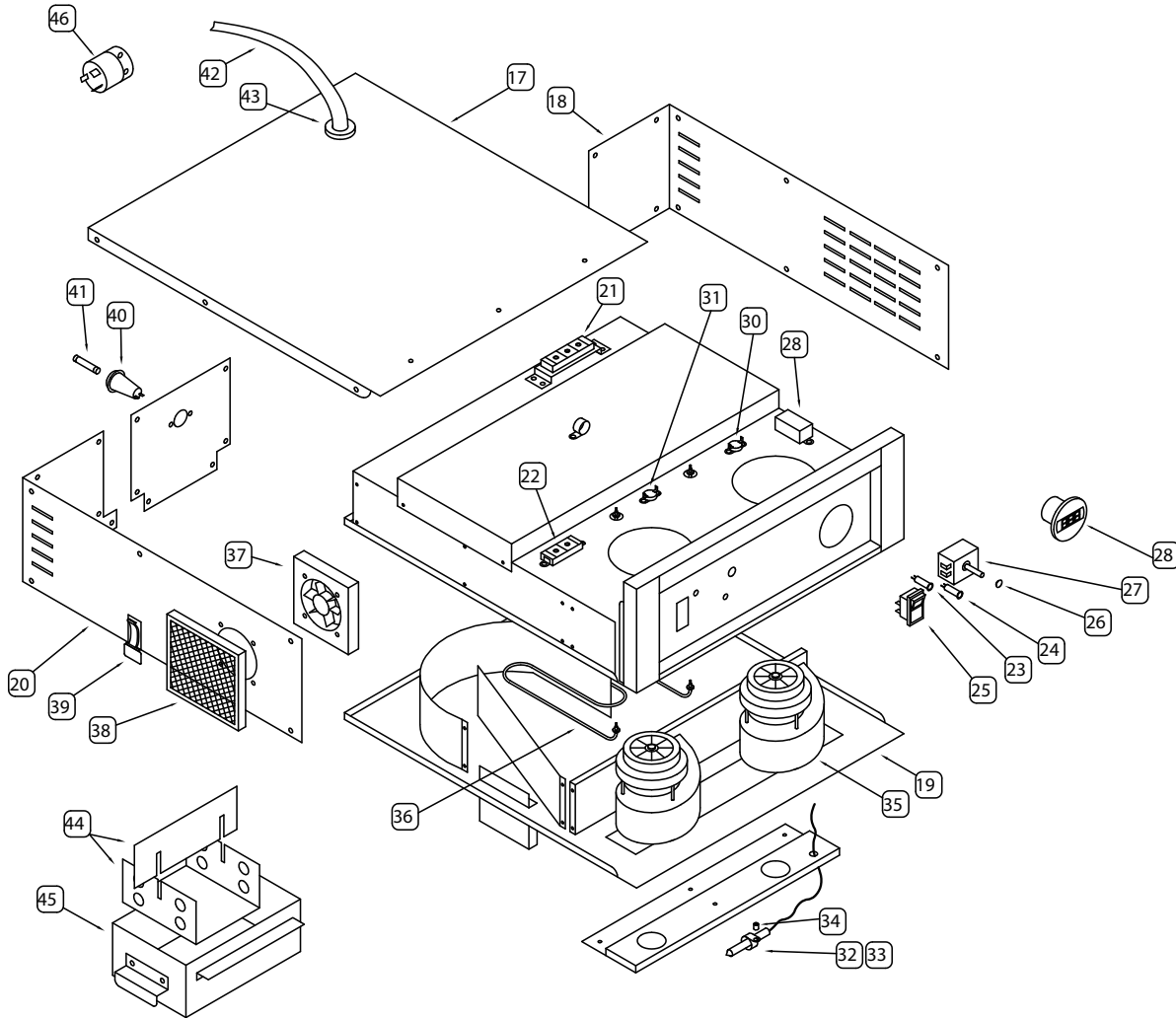

**HOT UNIT REPLACEMENT PARTS (Manufactured from 3/00 to present)**

Item	DESCRIPTION	REQ'D	Part No's. per Hot Unit	
			HU-18-671-44-G	HU-18-671-45-G
17	Cover, Top	1	6169-161	6169-161
18	Cover, RH Side	1	6169-162	6169-162
19	Bottom Plate	1	0672-310	0672-310
20	Cover, LH Side	1	6169-163	6169-163
21	Term. Block, Rear	1	0852-090	0852-090
22	Terminal Block	1	0852-091	0852-091
23	Pilot Light, Yellow	1	0766-094	0766-095
24	Pilot Light, Yellow	1	0766-094	0766-095
25	Switch Kit	1	0808-118-K	0808-116
40	Fuse Holder	1	0847-004	0847-004
27	Thermostat	1	0848-062-K	0848-062-K
28	Thermometer	1	5238-034	5238-034
29	Transformer 110V/220V	1	0769-159	0769-159
30	Vent Fan Switch	1	0848-034	0848-034
31	Hi-Limit Switch	1	0848-033	0848-033

Item	DESCRIPTION	REQ'D	Part No's. per Hot Unit	
			HU-18-671-44-G	HU-18-671-45-G
32	Clamp, T-Stat Bulb	1	0567-496	0567-496
33	" , Thermometer	1	0806-055	0806-055
34	Spacer	1	0818-017	0818-017
35	Blower Motor Kit	2	0769-005-K	0769-006-K1
36	Heater Kit	1	0811-022-K	0811-023-K
37	Vent Fan	1	0769-045-K	0769-029-K
38	Vent Fan Filter	1	0769-140	0769-140
39	Catch-Latch Ass'y.	2	1246-021	1246-021
41	Fuse	1	0807-048	0807-048
42	Power Supply Cord	1	0810-065	0810-039
43	Strain Relief Cord	1	0818-050	0818-050
44	Baffles	1	1052-063	1052-063
45	Humidity Pan	1	1017-076	1017-076
46	Plug, Twist Lock, Alt.	1	0840-036	Not Available

## HOT UNIT REPLACEMENT PARTS

**Manufactured from 10/97 thru 3/00)**  
*Include all information on nameplate when ordering parts*

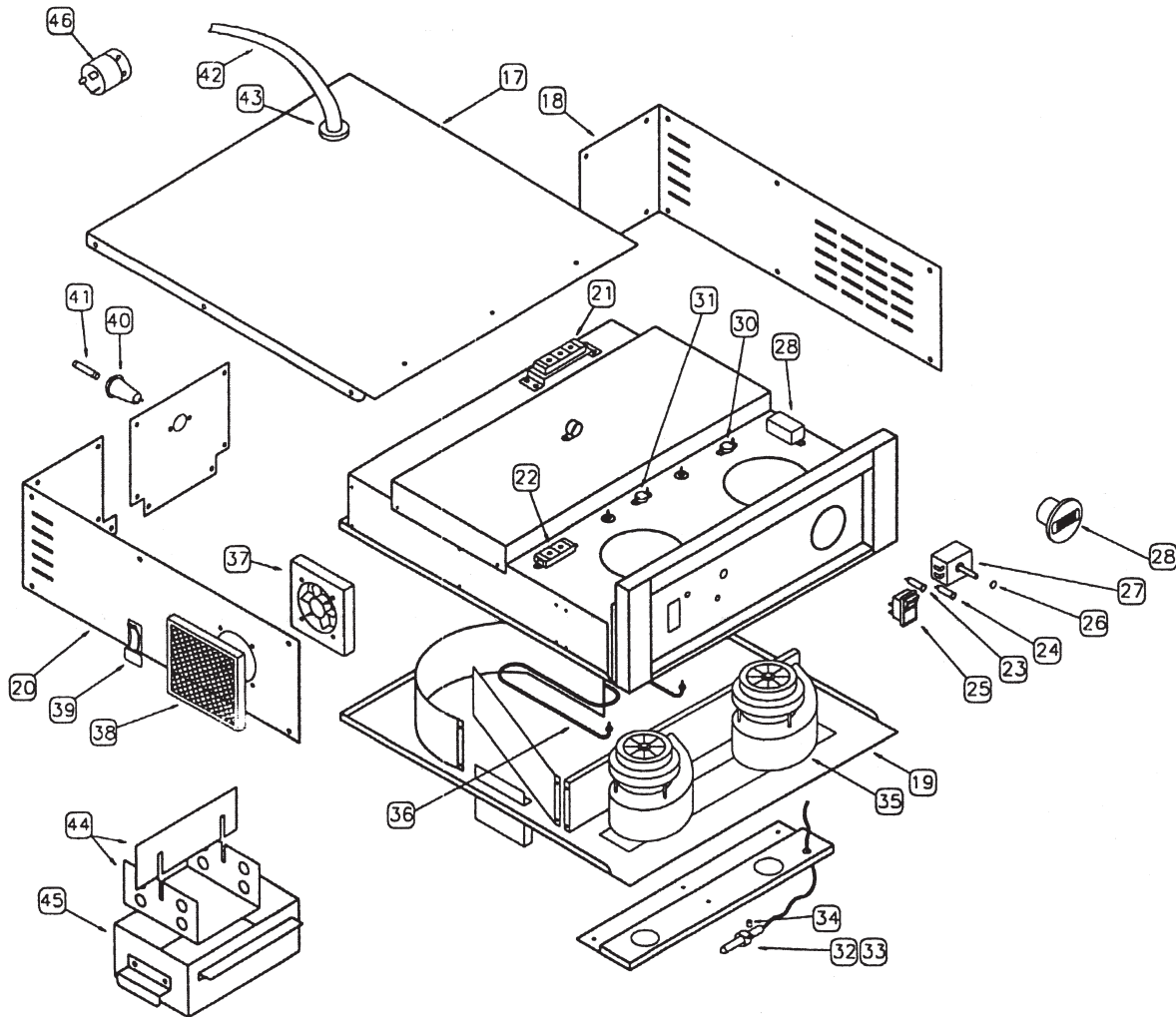

### HOT UNIT REPLACEMENT PARTS (Manufactured from 10/97 to 3/00)

Item	DESCRIPTION	REQ'D	Part No's. per Hot Unit		Item	DESCRIPTION	REQ'D	Part No's. per Hot Unit	
			HU-18-671-44-G	HU-18-671-45-G				HU-18-671-44-G	HU-18-671-45-G
17	Cover, Top	1	6169-161	6169-161	32	Clamp, T-Stat Bulb	1	0567-496	0567-496
18	Cover, RH Side	1	6169-162	6169-162	33	" , Thermometer	1	0806-055	0806-055
19	Bottom Plate	1	0672-310	0672-247	34	Spacer	1	0818-017	0818-017
20	Cover, LH Side	1	6169-163	6169-163	35	Blower Motor Kit	2	0769-005-K	0769-006-K1
21	Term. Block, Rear	1	0852-090	0852-090	36	Heater Kit	1	0811-022-K	0811-023-K
22	Terminal Block	1	0852-091	0852-091	37	Vent Fan	1	0769-045-K	0769-029-K
23	Pilot Light, Yellow	1	0766-094	0766-095	38	Vent Fan Filter	1	0769-140	0769-140
24	Pilot Light, Yellow	1	0766-094	0766-095	39	Catch-Latch Ass'y.	2	1246-021	1246-021
25	Switch Kit	1	0808-118-K	0808-116	40	Fuse Holder	1	0807-048	0807-048
26	Plug Button	1	0847-004	0847-004	41	Fuse	1	0807-058	0807-058
27	Thermostat	1	0848-062-K	0848-062-K	42	Power Supply Cord	1	0810-065	0810-039
28	Thermometer	1	5238-034	5238-034	43	Strain Relief Cord	1	0818-050	0818-050
29	Transformer 110V/220V	1	0769-159	0769-159	44	Baffles	1	1052-063	1052-063
30	Vent Fan Switch	1	0848-034	0848-034	45	Humidity Pan	1	1017-076	1017-076
31	Hi-Limit Switch	1	0848-033	0848-033	46	Plug, Twist Lock, Alt.	1	0840-036	Not Available

**\*\* Note:** When ordering replacement Hot Units, low-profile water pan 1017-076 is required.

Hot Cabinet	<b>FL-1917-KFC-M</b>
Rev. 14 (10/08)	Page 14 of 16

**HOT UNIT REPLACEMENT PARTS**  
**Manufactured thru 10/97)**  
*Include all information on nameplate when ordering parts*

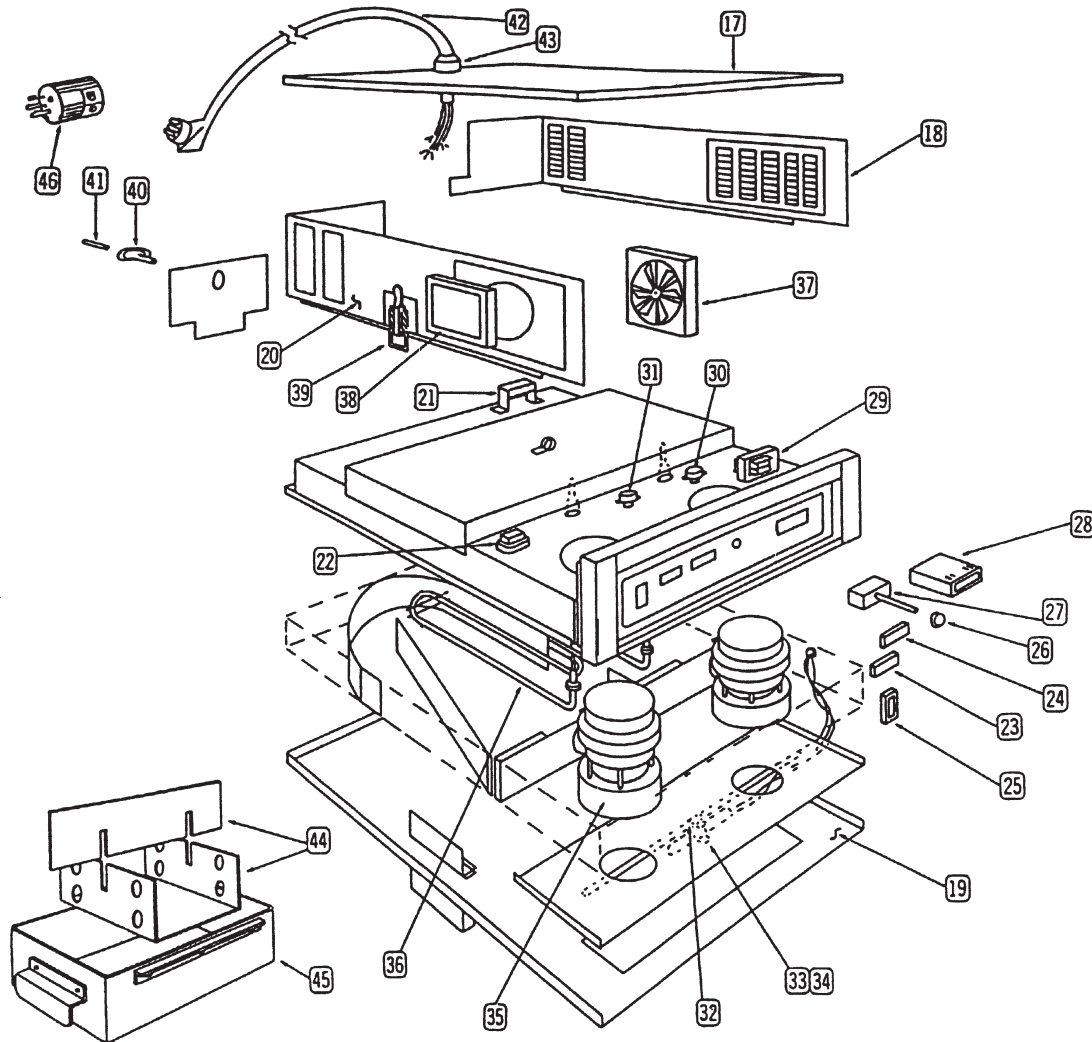

**HOT UNIT REPLACEMENT PARTS (Manufactured thru 10/97)**

Item	DESCRIPTION	REQ'D	Part No's. per Hot Unit	
			HU-18-671-44-F	HU-18-671-45-F
17	Cover, Top	1	6169-067	6169-067
18	Cover, RH Side	1	6169-083	6169-083
19	Bottom Plate	1	0672-162	0672-162
20	Cover, LH Side	1	6169-085	6169-084
21	Term. Block, Rear	1	0852-090	0852-090
22	Terminal Block	1	0852-091	0852-091
23	Pilot Light, Yellow	1	0766-048	0766-045
24	Pilot Light, Yellow	1	0766-047	0766-046
25	Switch Kit	1	0808-081	0808-080
26	Plug Button	1	0847-004	0847-004
27	Thermostat	1	0848-062-K	0848-062-K
28	Thermometer	1	5238-024	5238-024
29	Transformer 110V/220V	1	0769-159	0769-159
30	Vent Fan Switch	1	0848-034	0848-034
31	Hi-Limit Switch	1	0848-033	0848-033

Item	DESCRIPTION	REQ'D	Part No's. per Hot Unit	
			HU-18-671-44-G	HU-18-671-45-G
32	Clamp, T-Stat Bulb	1	0567-496	0567-496
33	" , Thermometer	1	0806-055	0806-055
34	Spacer	1	0818-017	0818-017
35	Blower Motor Kit	2	0769-005-K	0769-006-K1
36	Heater Kit	1	0811-022-K	0811-023-K
37	Vent Fan	1	0769-045-K	0769-029-K
38	Vent Fan Filter	1	0769-140	0769-140
39	Catch-Latch Ass'y.	2	1246-021	1246-021
40	Fuse Holder	1	0807-048	0807-048
41	Fuse	1	0807-058	0807-058
42	Power Supply Cord	1	0810-065	0810-039
43	Strain Relief Cord	1	0818-050	0818-050
44	Baffles	1	1052-063	1052-063
45	Humidity Pan	1	1017-0051	1017-051
46	Plug, Twist Lock, Alt.	1	0840-036	Not Available

## WIRING DIAGRAMS for 0671-044-G and 0671-045G

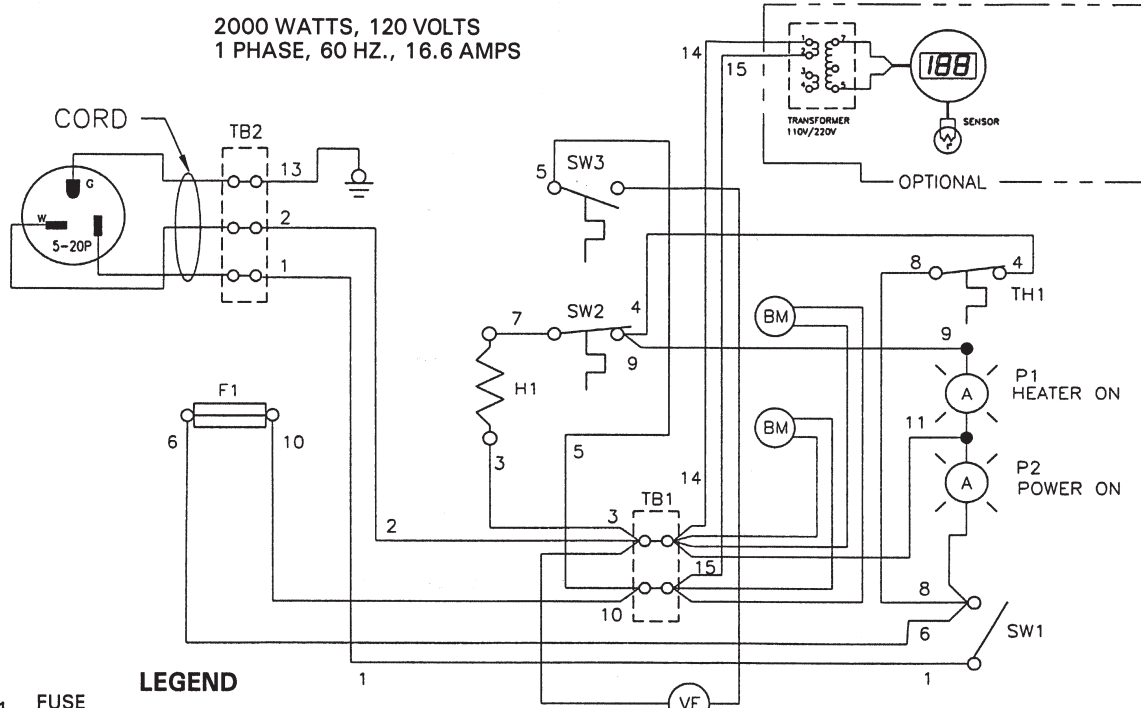

- LEGEND**
- |                |                               |                 |                       |
|----------------|-------------------------------|-----------------|-----------------------|
| F <sub>1</sub> | FUSE                          | SW <sub>1</sub> | SWITCH, SPST          |
| BM             | MOTOR-BLOWER                  | SW <sub>2</sub> | SWITCH, HIGH LIMIT    |
| H <sub>1</sub> | HEATER                        | SW <sub>3</sub> | SWITCH, VENT FAN      |
| P <sub>1</sub> | PILOT LIGHT, AMBER, HEATER ON | TH <sub>1</sub> | THERMOSTAT            |
| P <sub>2</sub> | PILOT LIGHT, AMBER, POWER ON  | TB <sub>1</sub> | TERMINAL BLOCK, Front |
| PS             | POWER SUPPLY, TEMP. DISPLAY   | TB <sub>2</sub> | TERMINAL BLOCK, Rear  |
| S1             | SENSOR                        | TD              | TEMPERATURE DISPLAY   |
|                |                               | VF              | VENT FAN              |
|                |                               | Δ               | SLEEVING              |

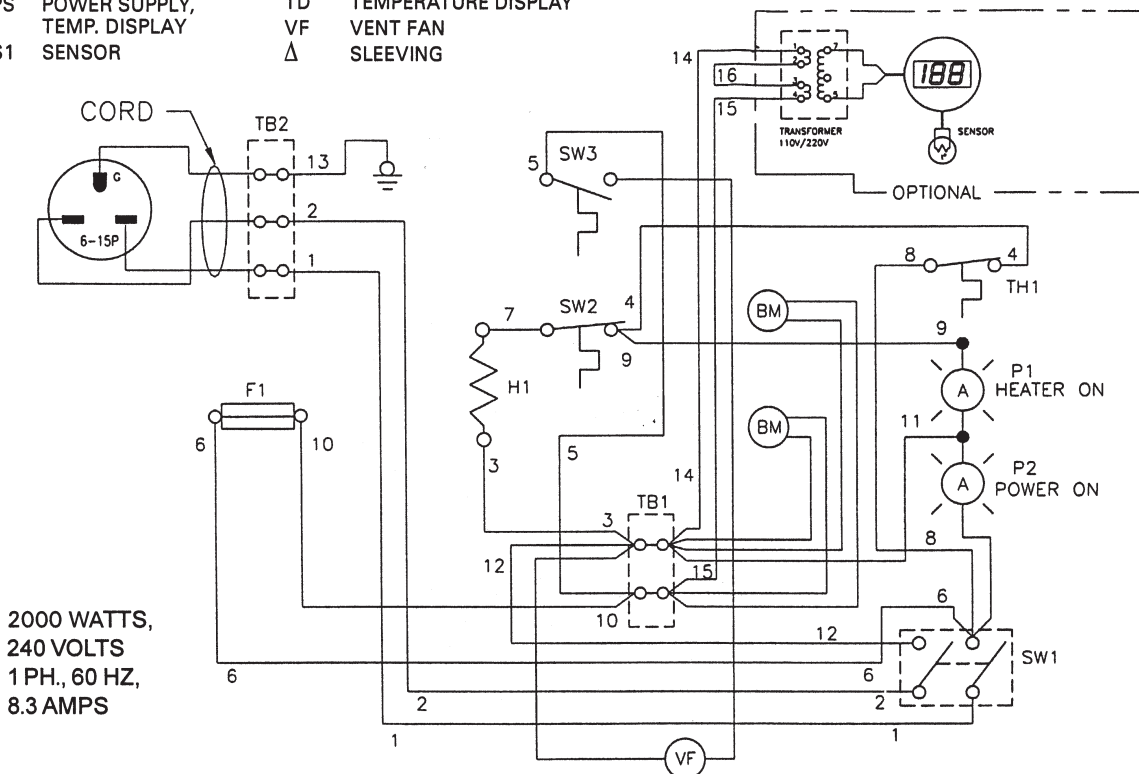

Hot Cabinet	<b>FL-1917-KFC-M</b>
Rev. 14 (10/08)	Page 16 of 16

**WIRING DIAGRAMS for 0671-044-F and 0671-045F**

2148 WATTS, 120 VOLTS  
 1 PHASE, 60 HZ., 16.6 AMPS

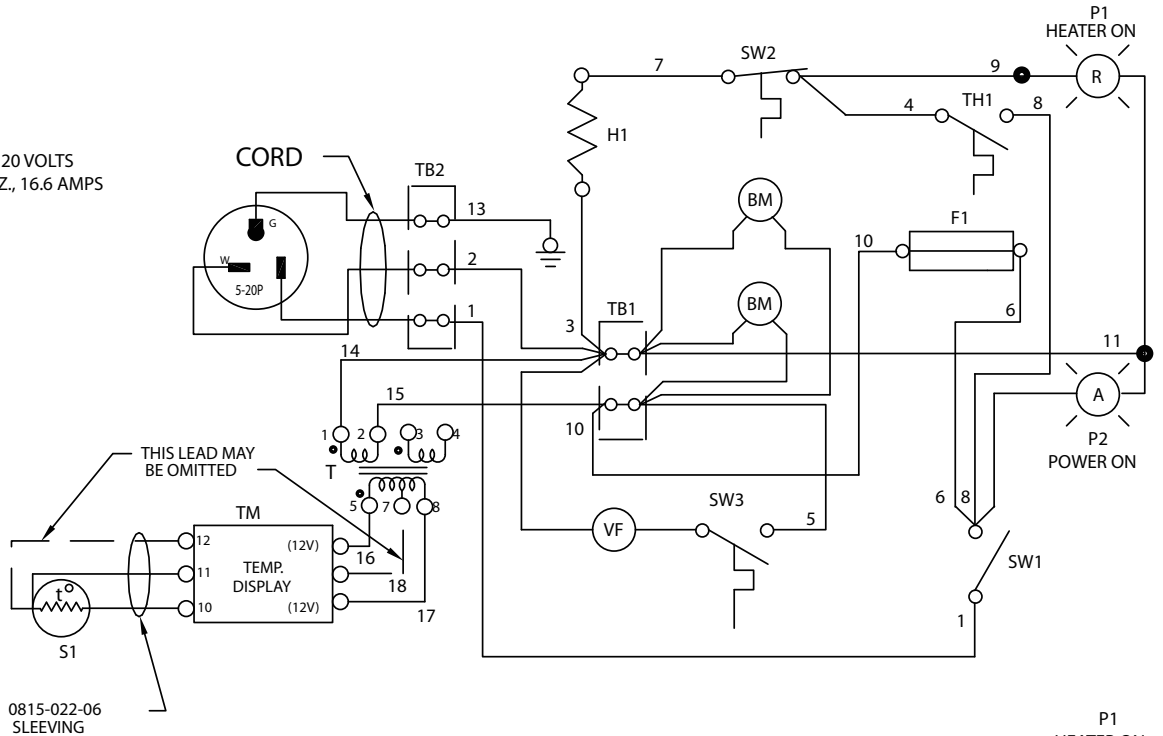

LEGEND

- F1 FUSE
- BM MOTOR- BLOWER
- H1 HEATER
- P1 PILOT LIGHT, RED, HEATER ON
- P2 PILOT LIGHT, AMBER, POWER ON
- S1 SENSOR
- SW1 SWITCH, SPST
- SW2 SWITCH, HIGH LIMIT
- SW3 SWITCH, VENT FAN
- T TRANSFORMER
- TH1 THERMOSTAT
- TB1 TERMINAL BLOCK
- TB2 TERMINAL BLOCK
- TM THERMOMETER
- VF VENT FAN
- Δ SLEEVING

2148 WATTS, 240 VOLTS  
 1 PHASE, 60 HZ., 8.3 AMPS

