

**INSTALLATION, OPERATION and MAINTENANCE
MANUAL for Cres Cor
RADIANT SMOKER OVENS**



**500-CH-SK-DE
500-CH-SK-DX**



**767-CH-SK-DE
767-CH-SK-DX
1000-CH-SK-DE
1000-CH-SK-DX**

Cabinet model number: _____

Cabinet serial number: _____

Authorized Service Agency: _____

Ph: _____ Fax: _____

Keep this manual for future reference.

Smoker Ovens	FL-2375
Rev. 7 (4/18)	Page 2 of 15

TABLE OF CONTENTS

SUBJECT	PAGE
INSTALLATION INSTRUCTIONS	3, 4
OPERATING INSTRUCTIONS	
First Time Operation	4
How to Use Control for Cooking & Holding:	
For “-DE” Series Ovens	5
For “-DX” Series Ovens	6
“Recipes” for “-DX” Series Ovens	7
OPERATING INSTRUCTIONS, SMOKER	
Replacement Parks for Smoker	8
Smoking Guidelines	9
MAINTENANCE INSTRUCTIONS	
How to Clean the Unit	10
Trouble Shooting Guide	11
Oven Illustration	12
Oven Replacement Parts	13
Wiring Diagram For 120 or 208/240 Volt, 1 Phase	14
Wiring Diagram for 208/240 Volt, 3 Phase	15
SERVICE POLICY and AGENCY LIST	FL-1400

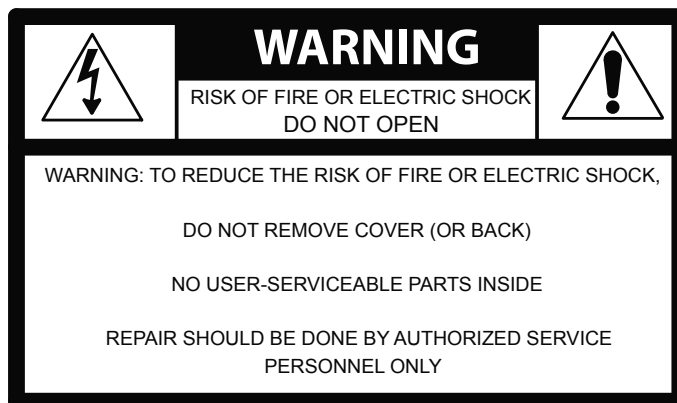

INSTALLATION INSTRUCTIONS

VENTING YOUR OVEN:

1. This cabinet passes the EPA 202 test and complies with section 59 of UL710B for emission of grease-laden air.
2. According to UL, this cabinet does not need to be placed under a ventilation hood *when used for cooking*.
NOTE: If using the smoker attachment on this cabinet, it is HIGHLY RECOMMENDED to place the unit under a ventilation hood.
3. Installation must conform with local codes. The authority having jurisdiction of enforcement of the codes will have the responsibility for making interpretations of the rules.

SPECIFICATIONS: All units are rated 3000 watts/2650 watts at 208 Volts/240 Volts

CMP MODEL NOS.	ELECTRICAL SPECS (AC SERVICE)			ELEC. LOAD		POWER SUPPLY REQUIREMENT				
	Volts	Ph	Hz.	Amps	Volts	Amps	Ph	Wire	Volts	NEMA
SINGLE OVENS										
500CHSKDE 767CHSKDE 1000CHSKDE	208 240	1 1	60 60	14 11	208 240	20 20	1 1	2 2	208 240	6-20P 6-20P
500CHSKDE3 767CHSKDE3 1000CHSKDE3	208 240	3 3	60 60	8 7	208 240	20 20	3 3	3 3	208 240	L15-20P L15-20P

SPECIFICATIONS: All units are rated 2000 watts.

CMP MODEL NOS.	ELECTRICAL SPECS (AC SERVICE)			ELEC. LOAD		POWER SUPPLY REQUIREMENT				
	Volts	Ph	Hz.	Amps	Volts	Amps	Ph	Wire	Volts	NEMA
SINGLE OVENS										
500CHSKDE120 767CHSKDE120 1000CHSKDE120	120	1	60	16.6	120	20	1	2	120	5-20P

“DE” in model number will be substituted with “DX” for “Deluxe” ovens.

All models designed for AC Service. Model number may include a variety of informational suffix letters.

NOTE: OVENS NEED TO BE INSTALLED BY A QUALIFIED PERSON.

For models rated at 208/240 Volts:
 Check the voltage selector switch which is under an access cover on the back of the oven near the power cord.

- * Flip the switch “UP” for 208 Volts
- * Flip the switch “DOWN” for 240 Volts

MAKE SURE THE SWITCH POSITION MATCHES YOUR POWER SOURCE.

Smoker Ovens	FL-2375
Rev. 7 (4/18)	Page 4 of 15



INSTALLATION INSTRUCTIONS (continued)

IDENTIFYING YOUR CABINET:

Look for this label on the back of your cabinet. This information is needed when calling for questions or service.

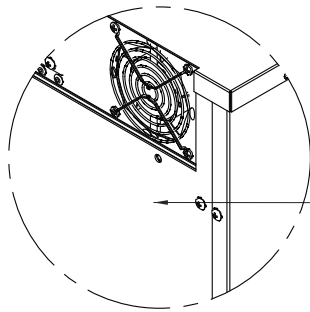

UPPER RIGHT CABINET CORNER



HOW TO INSTALL CABINETS:

1. Remove all packing material from the inside and all vinyl from the outside of oven.
2. Place the oven in a well ventilated area on level floor.
Clearance requirements: 3" (76mm) at the back, 2" (51mm) at the top, 1" (25mm) at both sides.
3. Install the pan slide racks on the sidewalls, if necessary.
4. Slide drip pan(s) onto the bottom of the compartment(s).

HOW TO REVERSE THE DOOR OPENINGS, IF NEEDED:

1. Unscrew and remove the latch from the door and magnetic strike from the cabinet.
2. Unscrew the hinges from the cabinet body and remove door.
3. Remove the screws plugging the mating hinge, latch and strike holes on the opposite sides of the cabinet body and door.
4. Re-mount the hinges to the opposite side of the cabinet and door.
5. Remount the latch and strike to the opposite side

DOOR VENT ADJUSTMENT:

Open the door(s) and move the vent tabs on the inner door(s) as needed to release humidity.

FOR FIRST-TIME OPERATION ONLY:

A new oven needs to "burn off" factory oils and glue before it's first use. **Do NOT load food into oven until this has been done!**

1. Push switch to "ON"; the light will come on.

NOTE: The letters "LOTPR" (low temperature) will show on the control panel until it reaches 140°F (60°C).

2. Press the "COOK" button.
3. Push down and turn the control knob to show 200°F. Push the knob again to set the temperature. Run the unit for one (1) hour.
4. Turn the unit off and let cool.
5. Wipe the inside clean with detergent and hot water.

HOW TO CHANGE FROM °F TO °C (if needed)

1. Push the switch on; the light will come on.
2. Push and hold the "SET" button and the button in the lower left hand corner together for 5 seconds. You have now entered into the menu.
3. Scroll over the "Unit" and change it to "C", then scroll to the "END".



Air is VERY HOT when door is opened.

OPERATING INSTRUCTIONS



HOW TO USE THE COOK-N-HOLD CONTROL:

*Push the lighted switch on the control panel; the oven will start heating and stay in HOLD mode.

*The display will read “LOTPr” (low temperature) below 140°F. (60°C.).

NOTES: Preheat for one (1) hour after start up before loading the food for best results when retherming or cooking heavy loads.

If a power outage occurs or the cabinet is shut off during a cook cycle, when it is turned on again all lights on the control will flash to indicate a disruption. Control will resume the last cook cycle used. Press any button to stop the blinking.

If your model does not have a food probe, continue to section “-DE OVENS” below.

If your model has a food probe, skip to section “-DX OVENS” on page 5.

-DE OVENS:

Cooking:

1. Press the COOK button.
2. Turn the control knob to the desired cooking temperature between 180°F (82°C) and 350°F (176°C).
3. Push the knob to set the temperature.
4. The control automatically switches to allow you to set HOLD temp. (Continue to step 1 below).

Holding:

(To use as holding cabinet only, skip steps 1-4 above and press HOLD button. Complete steps 1-3 below.)

1. Turn the control knob to the desired holding temperature between 135°F (57°C) and 220°F (104°C).
2. Push the knob to set the temperature.
3. The control automatically switches to allow you to set cook time.

Setting the Timer:

1. Turn the control knob to the desired hours/minutes.
2. Push the knob to set the time.
3. The control automatically switches to PREHEAT mode and will display “PrEHt”

Running the Cycle:

1. The control will flash “PUSH StArt” after the cabinet has preheated to the set temp and the alarm will sound.

NOTE: A short beep will occur every 90 seconds as a reminder. This can be turned off in the user menu by holding the knob and the TIME buttons together for 5 seconds, then scrolling to “PSrE”, changing “y” to “n”, scrolling to “End”, and pushing the knob to set.

2. Load foods into oven and close the door.
3. Push the START button to begin the Retherm/Cook process. Display will change between the setpoint temperature and the countdown of the timer.
4. The alarm will sound after the time is done and the oven will switch back into HOLD mode. The timer will now count up, showing how long the food has been holding.

Smoker Ovens	FL-2375
Rev. 7 (4/18)	Page 6 of 15

OPERATING INSTRUCTIONS (*continued*)



-DX OVENS

Cooking:

1. Press the COOK button.
2. Turn the control knob to the desired cooking temperature between 180°F (82°C) and 350°F (176°C).
3. Push the knob to set the temperature.
4. The control automatically switches to allow you to set HOLD temp. (Continue to step 1 below).

Holding:

(To use as holding cabinet only, skip steps 1-4 above and press HOLD button. Complete steps 1-3 below.)

1. Turn the control knob to the desired holding temperature between 135° (57°C) and 220°F (104°C).
2. Push the knob to set the temperature.
3. The control automatically switches to allow you to set cook time.

If cooking with timer, continue to step 1 below. If cooking with food probe, skip to section “Cooking with Food Probe”.

Cooking with Timer:

1. Turn the control knob to the desired hours/minutes. Oven will switch from COOK to HOLD mode when this time is done.
2. Push the knob to set the time.
3. Oven will switch to PREHEAT mode and control will display “PrEHt”.

Cooking with Food Probe:

NOTE: Make sure probe was plugged in after step 1 of Holding above. If not, press the PROBE button and continue to next step below.

1. Turn the control knob to the desired temperature. The oven will switch from COOK to HOLD mode when the probe reaches this temp.
2. Push the knob to set the temperature.
3. Oven will switch to PREHEAT mode and control will display “PrEHt”.

Running the Cycle:

1. The control will flash “PUSH StArt” after the cabinet has preheated to the set temp and the alarm will sound.

NOTE: A short beep will occur every 90 seconds as a reminder. This can be turned off in the user menu by holding the knob and the TIME buttons together for 5 seconds, then scrolling to “PSrE”, changing “y” to “n”, scrolling to “End”, and pushing the knob to set.

2. Load foods into oven, insert probe (if applicable) and close the door.
3. Push the START button to begin the Retherm/Cook process.
 - a. If cooking with timer, display will alternate between the setpoint temperature and the countdown of the timer.
 - b. If cooking with probe, display will show the probe temp.
4. The alarm will sound after the time is done and the oven will switch back into HOLD mode. The timer will now count up, showing how long the food has been holding.

NOTE: At any time, the CANCEL button can be pushed to return the oven back to HOLD mode at the previous set temperature.

The DISPLAY button shows (cycles through) all the values when in each mode:

- “PrEHt” or “PUSH StArt”: Momentarily shows actual oven temperature.
- “COOK (timed)”: Shows home screen, set point, count down time, actual oven temperature.
- “COOK (probe)”: Shows home screen, set point, count up time, actual oven temperature.
- “HOLD”: Shows home screen, set point, count up time, actual oven temperature.

OPERATING INSTRUCTIONS *(continued)*



-DX OVENS, *continued*

RECIPES:

The -DX control can hold up to 18 saved recipes.

To save a recipe:

1. Press the RECIPE button.
2. Turn the knob through the menu until you get to “Edit” and press the knob.
3. Turn the knob to reach the recipe you want to edit. There are 18 blank recipes to customize and save.
4. Press the knob and enter the cook, hold and time values.
5. After the entering the final value, “Edt” will show again, allowing you to edit another recipe.
6. Press the knob to edit more recipes or turn to “End” to exit the menu.

To use one of the recipes:

1. Push the RECIPE button.
2. Turn the knob to the desired recipe; “rcP01”, “rcP02”, “rcP03”, etc.
3. Push the set button to select and start the preset process. Unit will begin to preheat.
4. Run the cycle as described above by pressing START button after oven has preheated.

Note: The display button will cycle through all the values as before, but will include the recipe number, if using a saved recipe.

Additional Menu Settings:

Press and hold both the TIME button and the knob for 5 seconds to get into the menu.

Here you can set the recipes, temperature units (°C or °F), PUSH START reminder and the datalog settings (USB connection required):

”RECE” allows you to enable or disable the data record feature.

“RECF” allows you set how often (in minutes) a datapoint will be recorded.

“RECD” allows you to set how long (in days) you would like the data to be stored in memory.

Smoker Ovens	FL-2375
Rev. 7 (4/18)	Page 8 of 15

SMOKING PROCEDURES

1. Soak hard wood chips for 1 to 24 hours. Drain chips and place into the chip holder, close the cover.

FOR HOT SMOKING: Turn on the oven power and set the controls per the cooking and holding operating instructions on page 5, and pre-heat until “rEADy” is displayed and oven is up to the set cooking temperature. Refer to page 8 for times and temperatures.

FOR COLD SMOKING: Do not turn on the oven power. Using frozen CRES COR KOLD KEEPERSTM or 12”x20” pans of ice, place the KOLD KEEPERSTM or hotel pans of ice directly above the smoke generator and beneath the wire grids holding the food items to be smoked.

2. Slide the chip holder into the oven. Make sure the container is securely over the heater.
3. Load the prepared food product into the oven cavity. (Cured, rubbed, seasoned)
4. Close all door vents.

5. Set the Smoke Timer:
 - a. Turn the timer knob clockwise to the required minutes.
 - b. The yellow light for the timer will come on.
 - c. The timer will count down to the “Off” position and the yellow light will go off.



WOOD CHIP CONTAINER MAY REMAIN HOT.

After wood chips fully extinguish and the holder cools, remove and empty ashes before reloading.

NOTE: Put the wood chip container back into position inside the cabinet when not in use to protect the exposed heat element.

CLEANING OVEN AFTER SMOKING FOOD:

Use a quality stainless steel oven cleaner, scrubbers and towels to remove residual grime. Recommended to clean the oven after each use.

REPLACEMENT PARTS FOR SMOKER:

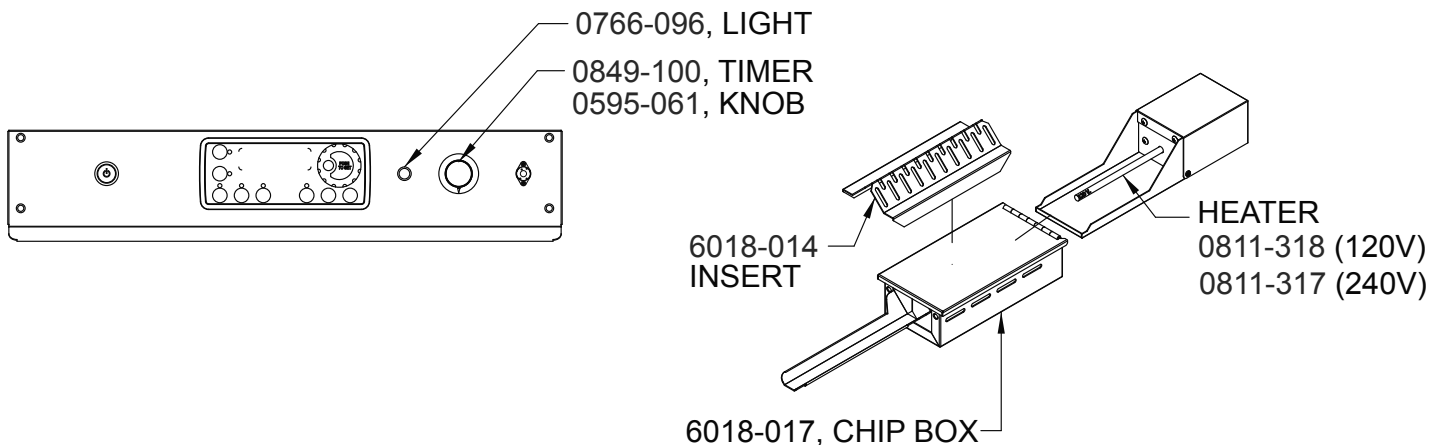

PRODUCT	SIZE/ PORTION	MAXIMUM LOAD	COOK	HOLD	COOK TIMER	SMOKE TIMER	FINAL INTERNAL	MINIMUM HOLD
Pork Ribs	2-1/2 lb. Down	3 Wire shelves	250°F	160°F	3 hours	60 minutes	165°F	60-90 min.
Pork Shoulder	7-8 lb. ea.	2 shelves, 4 butts per	250°F		12 min. per lb. 20 min. per additional roast	2-3 hours	170°F	2-3 hours
Fresh Hams	15-15 lb. ea.	2 shelves, 3 hams per	250°F		12 min. per lb. 30 min. per additional roast	3-4 hours	170°F	2-3 hours
Pork Chops/Loin	12-16 oz. ea.		250°F	150°F	2 hours	30-45 min.	150°F	30 min.
Beef Brisket	10-12 lb. ea.	3 shelves, 3 roasts per	250°F	160°F	20 min. per lb. 30 min. per additional roast	1 hour	165°F	6 hours
Turkey, Whole	22 lb. avg.	1 shelf, 2 birds	250°F	160°F	10 min. per lb. 30 min. per additional bird	1 hour	180°F	60-90 min.
Chicken, Whole	2-1/2 lb. ea.	2 shelves, 8 birds per	275°F	160°F	3 hours	30-45 min.	180°F	60 min.
Duck, Whole	4-5 lb. ea.	2 shelves, 6 ducks per	300°F	160°F	3-1/2 to 4 hours	1 hour	185°F	60 min
Fish, Fillets (Cod, Haddock, Grouper)	6 oz. ea.	2, 12" x 20" pans per level 6 pans total	250°F	160°F	1-1/2 to 2 hours	1 hour	150°F	Minimal/0
Salmon, Whole	8-10 lb. ea.	2 fish per 18" x 26" x 1" 3 pans max. load	275°F	160°F	2 hours	1-2 hours	150°F	Minimal/0
Shrimp	16-20 count	4, 18" x 26" x 1" pans	250°F	160°F	45 minutes	45 min.	150°F	Minimal/0
Cold Smoking	Salmon Fillets, Cheeses, etc.	3 shelves with wire grids	OFF	OFF	OFF	20 min.	75°F	2 hours

Helpful Hints:

1. Soak wood chips thoroughly, from 15 minutes to overnight.
2. Use of foil potato wrap under wood chips, inside the chip container, will assist in clean-up process.
3. For cold smoking, slide 2 of the *Cres Cor* Kold Keepers™ or 12" x 20" pans of ice, just above the smoke generator for cooling.
4. Smoke Flavors: LIGHT @ 10-15 min. / MEDIUM @ 20-30 min. / HEAVY @ 40-45 min. / STRONG @ 60 min. Reload wood chips after 60 minutes.
5. These are starting guidelines. Experiment and adjust the times, temperatures, brines, rubs and woods to achieve your layers of flavors.

HOW TO CLEAN THE UNIT:

WARNING

BEFORE cleaning the cabinet:

1. **Unplug cord from wall. Allow cabinet to cool.**
 2. **Do NOT hose cabinet with water.**
 3. **Do NOT get water on controls.**
 4. **Do NOT use abrasives or harsh chemicals.**
- Wipe up spills as soon as possible.
 - Clean regularly to avoid heavy dirt build-up.

Cleaning Hints:

1. Use the mildest cleaning procedure that will do the job.
2. Always rub in the direction of polish lines to avoid scratching the surface.
3. Use only a soft cloth, sponge, fibrous brushes, plastic or stainless steel pads for cleaning and scouring.
4. Rinse thoroughly with fresh water after every cleaning operation.
5. Always wipe dry to avoid water marks.

	SOIL	CLEANER	METHOD
STAINLESS STEEL CABINET Inside and Outside	Routine Cleaning	Soap or mild detergent* and water.	1. Sponge on with cloth 2. Rinse
	Stubborn Spots, Stains	Mild abrasive made for Stainless Steel.	1. Apply with damp sponge or cloth. 2. Rub lightly.
	Burnt on Foods or Grease	Chemical oven cleaner made for Stainless Steel.	Follow oven cleaner manufacturer's directions.
	Hard Water Spots & Scale	Vinegar	1. Swab or wipe with cloth. 2. Rinse and dry.

**Mild detergents include soaps and non-abrasive cleaners.*

MAINTENANCE INSTRUCTIONS TROUBLE-SHOOTING GUIDE

 WARNING IF UNIT GETS TOO HOT OR WON'T SHUT OFF, DISCONNECT POWER AT BRANCH PANEL. DO NOT UNPLUG CORD!

If hot unit is *NOT* working, first check the following causes:

- | | |
|--|--|
| 1. Cord is unplugged from wall outlet. | 3. Switch(es) are turned off. |
| 2. Circuit breaker/fuse to wall outlet is blown. | 4. Thermostat(s) are turned off, or are set too low. |

IF THE OVEN TURNS ON:

PROBLEM	POSSIBLE CAUSE	SOLUTION
Oven does not heat, or doesn't heat properly	1. Sensor 2. Heater relay 3. Loose connection 4. Oven control 5. High Limit	1. Replace 2. Replace 3. Replace 4. Replace 5. Replace
Heater will not shut off	1. Control defective 2. Heater relay	1. Replace 2. Replace
Vent fans do not shut off	1. Vent fan switch defective 2. Control compartment is still hot.	1. Replace 2. Wait until it cools Check "Heater will not shut off"
Vent fans do not operate (See Note)	1. Vent fan switch defective 2. Vent fan defective	1. Replace 2. Replace
Control will not switch from "COOK" to "HOLD" (timed mode)	1. Oven is in "PROBE" mode (DX oven). 2. Oven control defective	1. Cancel recipe and switch to "TIMED" mode 2. Replace
Control will not switch from "COOK" to "HOLD" (probe mode in DX ovens only)	1. Oven is in the "TIMED" mode 2. Probe not plugged in 3. Probe defective 4. Oven control defective	1. Cancel recipe and switch to "PROBE" mode 2. Plug in probe 3. Replace 4. Replace
Control will not switch to "COOK" (probe mode in DX ovens only)	1. Oven in "TIMED" mode 2. Probe temperature setting lower than probe temperature 3. Probe not plugged in 4. Oven control defective	1. Switch to "PROBE" mode 2. Set probe temperature to desired temperature 3. Plug in probe 4. Replace

ERROR CODES:

CODE DISPLAYED	CAUSE	SOLUTION
no p	No meat probe	Plug in probe
Err0	Temp probe bad	Replace

NOTE: Vent fans will not operate until the control compartment requires ventilation to limit temperatures. Replacement of electrical components must be done by a qualified electrician. Refer to our *Service Agency list, FL-1400* (found in the back of this manual), of authorized service centers. Instructions for replacing parts are included in replacement parts list.

Smoker Ovens	FL-2375
Rev. 7 (4/18)	Page 12 of 15

REPLACEMENT PARTS

Include all information on nameplate when ordering parts

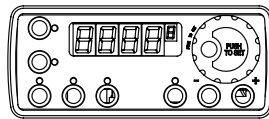
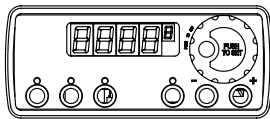
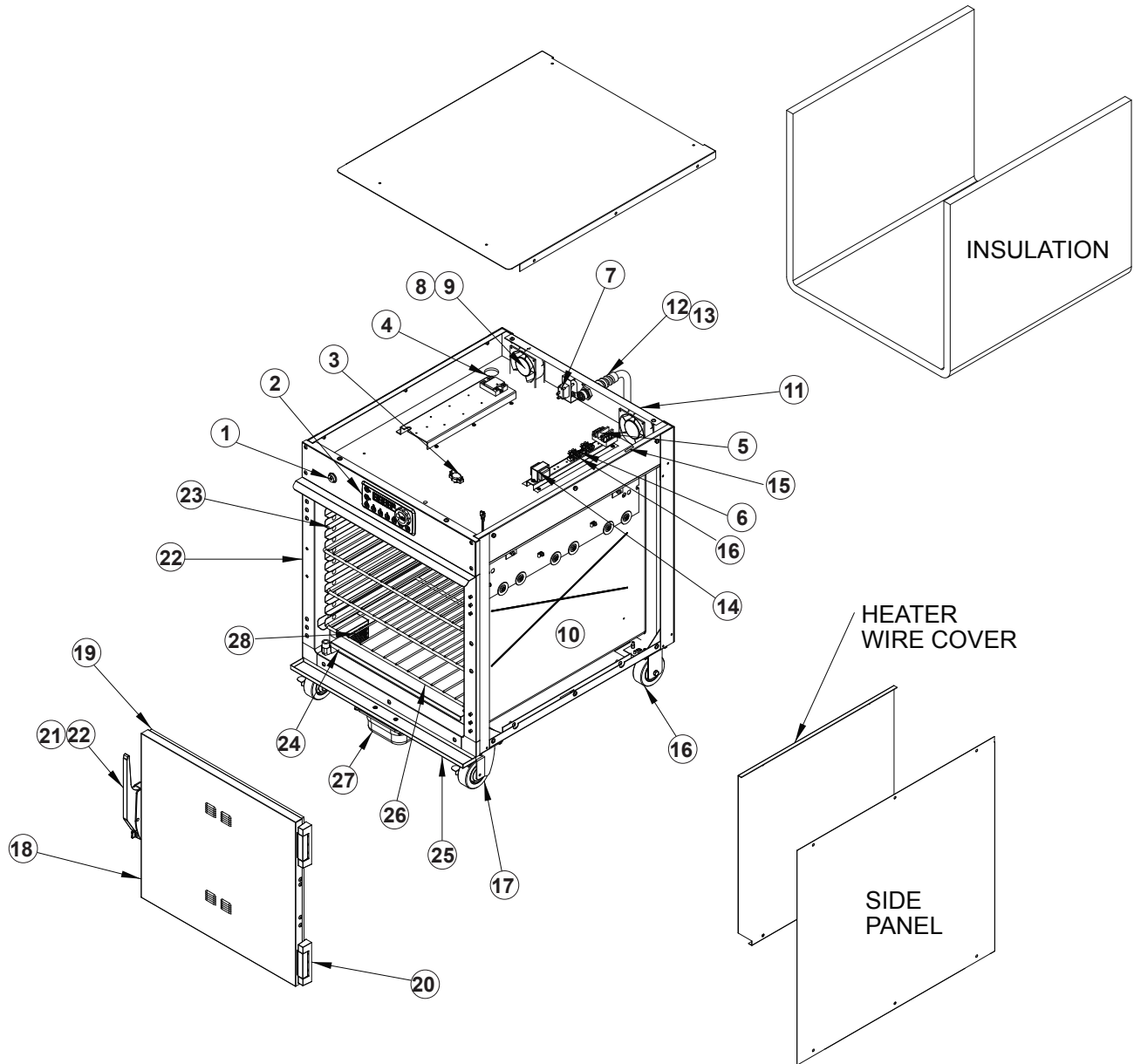

2A "DE" COOK-N-HOLD CONTROL

2B "DX" COOK-N-HOLD CONTROL

REPLACEMENT PARTS

Include all information on nameplate when ordering parts

ELECTRICAL REPLACEMENT PARTS

ITEM DESCRIPTION	CMP Part No.	ITEM DESCRIPTION	CMP Part No.
1. Switch (On/Off)	0808-125	9. Fan Guard	0769-167
2A. "DE" Digital Control	0848-092-24-K	10. Heater Kit 240V, 1325W	0811-296-K
2B. "DX" Digital Control	0848-092-08-K	Heater Kit 120V, 1000W	0811-295-K
2C. Digital Control Probe	0848-091-K	11. Hi-Limit	0848-033
3. Switch, Fan	0848-034	12. Power Cord (3000W, 1Ph)	0810-173-01-K
4. Relay	0857-136	Power Cord (3000W, 3Ph)	0810-164-02
5. Terminal Block (Input, 2 Pole)	0852-109	Power Cord (2000W, 1Ph)	0810-065-1
6. Terminal Block (3 Pole)	0852-091	13. Strain Relief	0818-050
7. Switch, toggle	0808-020	14. Transformer	0769-197
8. Vent Fan (240V)	0769-174	15. Alarm Ass'y	0908-009-01
Vent Fan (120V)	0769-165	16. Terminal Block (4 Pole)	0852-119

CABINET REPLACEMENT PARTS

ITEM DESCRIPTION	500-CH-SS-D	750-CH-SS-D	1000-CH-SS-SPLIT-D
16. Casters, Rigid	0569-288	0569-288	0569-306-R
17. Casters w/ Brake	0569-287-B	0569-287-B	0569-306-B
18. Door Assembly	1221-570-K	1221-576-K	1221-573-K
19. Door Gasket	0861-270	0861-269	0861-267
20. Hinge Kit (2)	0519-109-K	0519-109-K	0519-109-K
21. Door Latch Kit	1006-122-01-K	1006-122-01-K	1006-122-01-K
22. Latch Strike Kit	1006-122-02-K	1006-122-02-K	1006-122-02-K
23. Pan Slides	0692-202	0692-203	0692-200
24. Drip Pan Ass'y	1017-109	1017-102	1017-115
25. Drip Tray	1017-107	1017-118	1017-112
26. Wire Shelf	1170-030-SS	1170-217	1170-212
27. Clear Drip Pan	1017-058	1017-058	1017-058
28. Strainer	1052-094	1052-093	1052-094

FOR "DX" OVENS ONLY (not shown):

Probe, Food	0848-112	0848-112	0848-112
Probe Connector	0848-106-02	0848-106-02	0848-106-02

Smoker Ovens	FL-2375
Rev. 7 (4/18)	Page 14 of 15

WIRING DIAGRAM 120 or 208/240 Volt, Single Phase

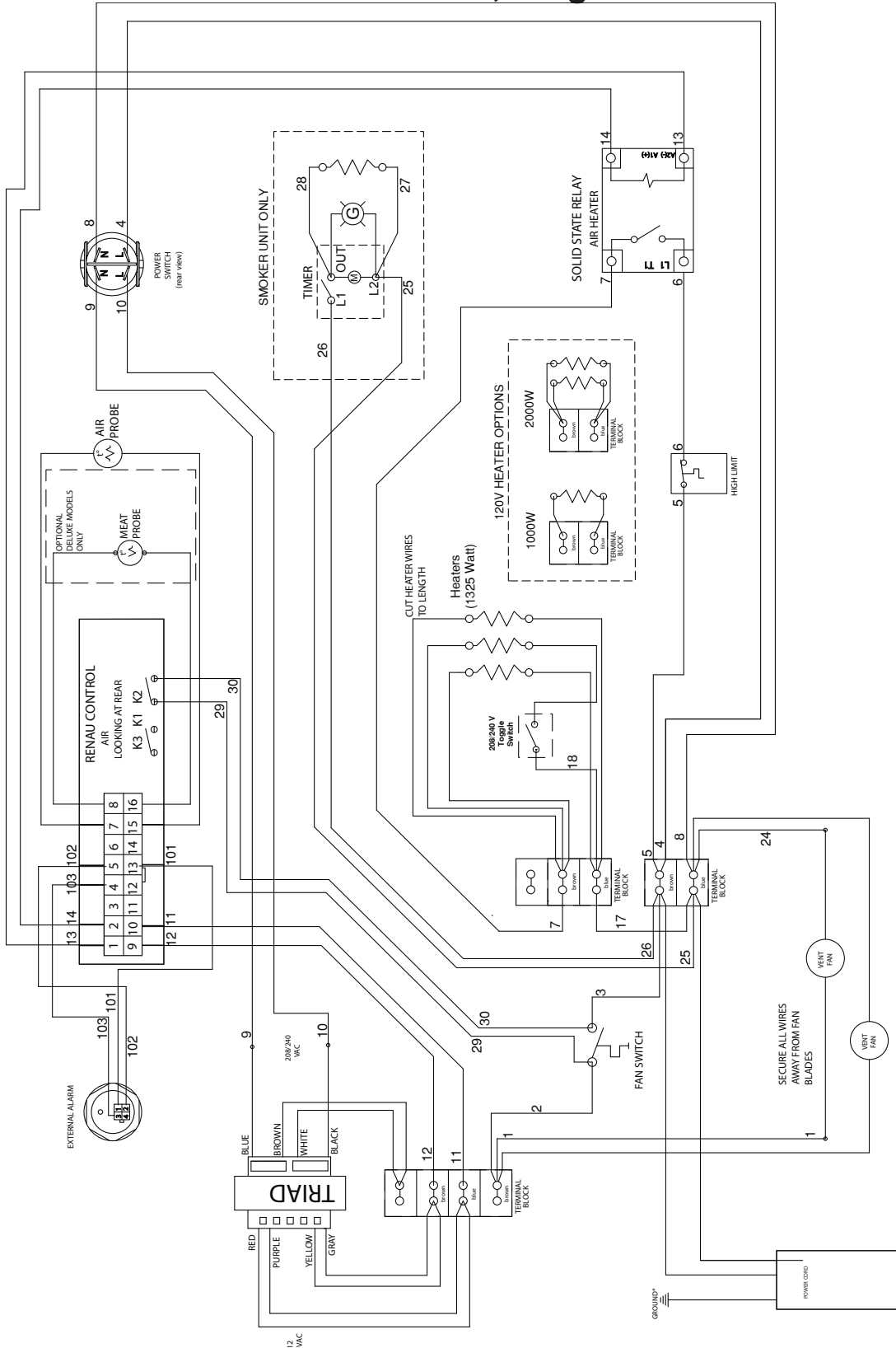

WIRING DIAGRAM 208/240 Volt, Three Phase

