

OPERATING and MAINTENANCE INSTRUCTIONS

Models: H137PUA...C/H138P1834C and H137PSUA...C/H138PS1834C Pass-Thru Series Hot Cabinets

ELECTRICAL SPECIFICATIONS:

Model No.	Volts	Watts	Amps	Hertz	Phase	NEMA
H137PSUA12C H137PUA12C H137PSUA9C H137PUA9C H137PSUA6C H137PUA6C H138PS1834C H138P1834C	120	2000	16.7	60	1	5-20P
H137PSUA12C208 H137PUA12C208 H137PSUA9C208 H137PUA9C208 H137PSUA6C208 H137PUA6C208 H138PS1834C208 H138P1834C208	208	2000	10.0	60	1	6-15P
H137PSUA12C240 H137PUA12C240 H137PSUA9C240 H137PUA9C240 H137PSUA6C240 H137PUA6C240 H138PS1834C240 H138P1834C240	240	2000	8.6	60	1	6-15P

Note: The above model numbers are basic models. They may be followed by letters: **L**, **M**, **2M**, **D** or ending with **S** and/or **Z**

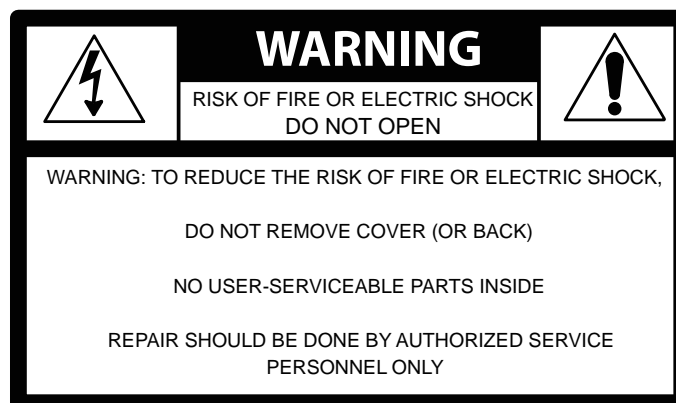

Pass-Thru Hot Cabinet	FL-2254
Rev. 7 (7/08)	Page 2 of 5

OPERATING and MAINTENANCE INSTRUCTIONS

Models: H137PUA...C/H138P1834C and H137PSUA...C/H138PS1834C

Pass-Thru Series Hot Cabinets

HOW TO INSTALL UNIT:

1. Place cabinet on level floor.
2. Plug cord into proper wall outlet.

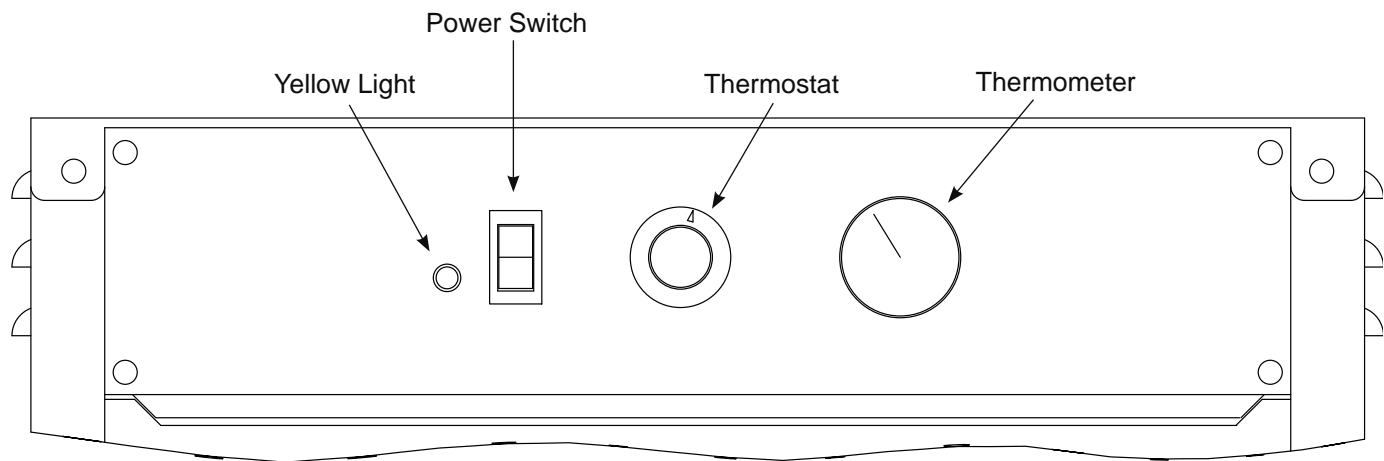

HOW TO START UNIT:

1. Push *POWER* switch to **ON**. The *yellow* light will turn on.
2. Turn thermostat knob to #7.
3. Preheat cabinet for 60 minutes.
4. Put food into cabinet.
5. Turn thermostat to #8 and close door.
 No. 8 setting = approx. 185°F/85°C
 No. 6 setting = approx. 160°/71°C
 No. 4 setting = approx. 130°/54°C

NOTE: Proper food holding temperature is 140°F/60°C or higher.

Note: The optional digital thermometer display flashes when center of cabinet is below 140°F (60°C) or above 250°F (121°C). Call the factory if you need different settings.

TO TURN OFF UNIT:

Push the *POWER* switch to **OFF**.
The *yellow* light will go out.

OPERATING and MAINTENANCE INSTRUCTIONS

Models: H137PUA...C/H138P1834C and H137PSUA...C/H138PS1834C

Pass-Thru Series Hot Cabinets

WARNING

BEFORE Cleaning the Cabinet:

1. Allow cabinet to cool.
2. Do NOT use abrasives or harsh chemicals.

Is your cabinet of aluminum or stainless steel construction?
Be sure your cleaner is suitable for that material.

NOTE: Stainless steel cabinets have “S” in the model number.

Cleaning Notes:

1. Wipe up spills as soon as possible.
2. Clean cabinet regularly to avoid heavy dirt build-up.
3. Make a test spot with cleaner.
4. Follow manufacturer’s directions on cleaner.
5. Do not mix cleaners.
6. Avoid drips and splashes.

HOW TO CLEAN UNIT:

SOIL	CLEANER	METHOD
DIRT	Mild detergent* and hot water, or mild abrasive cleaner.	1. Use soft, damp cloth. 2. Rinse with hot water 3. Wipe dry.
	Steam (no strong alkaline additive).	1. Rinse after steam cleaning. 2. Wipe dry.
FINGERPRINTS, GREASE and OIL	Chemical oven cleaner.	Follow oven cleaner manufacturer’s directions
	Mild abrasive cleaner; oily or waxy cleaner.	Apply with a soft, clean cloth.
WATER SPOTS	Mild abrasive cleaner.	1. Apply with damp cloth. 2. Rinse and dry.
<i>*Mild detergents include soaps and non-abrasive cleaners.</i>		

Note: Gaskets are removable for cleaning.

TROUBLE-SHOOTING CHART:

FAILURE:

1. Yellow light on switch does NOT light.
2. Unit does not heat.
3. Unit gets too hot or won’t shut off.
4. Blower does not work or makes noise.

POSSIBLE CAUSE:

- 1a. Circuit breaker/fuse to wall outlet is blown
- 1b. Cord is unplugged from wall outlet.
- 1c. Switch is “OFF.”
- 2a. Thermostat set too low or is “OFF.”
- 2b. Switch is “OFF.”
- 3a. Defective electrical parts.
- UNPLUG UNIT FROM WALL OUTLET.**
- 4a. Defective blower

If cause is none of the above, refer to our list of Authorized Service Centers, FL-1400

Pass-Thru Hot Cabinet	FL-2254
Rev. 7 (7/08)	Page 4 of 5

OPERATING and MAINTENANCE INSTRUCTIONS

Models: H137PUA...C/H138P1834C and H137PSUA...C/H138PS1834C

Pass-Thru Series Hot Cabinets

REPLACEMENT PARTS

DESCRIPTION		120 Volt	208 Volt	240 Volt
Power Unit	2000w	0675-004	0675-005	0675-005
	2000w + digital therm	0675-004-D	0675-005-D	0675-005-D
Heater kit, air	-2000w	0811-074		0811-074-01
	(2-1000w)			
High Limit		0848-060	0848-060	0848-060
Thermometer	-analog	5238-030	5238-030	5238-030
	-digital	5238-034	5238-034	5238-034
Transformer <i>(used with digital thermometer)</i>		0769-159	0769-159	0769-159
Thermostat, air	-analog	0848-062-K	0848-062-K	0848-062-K
	-solid state	0848-008-ACK	0848-008-ACK	0848-008-ACK
Power Cord		0810-065-10	0810-039-02	0810-039-02
Power Switch		0808-116	0808-116	0808-116
Power Light		0766-094	0766-095	0766-095
Vent fan		0769-165	0769-174	0769-174
Blower Kit		0769-180-K	0769-182-K	0769-182-K
Door, complete	-aluminum	UA12/UA6/1834	1221-524	
	-aluminum	UA9	1221-527	
	-stainless steel	UA12/UA6/1834	1221-525	
	-stainless steel	UA9	1221-526	
Door, gasket	-aluminum	UA12/UA6/1834	0861-235	
	-aluminum	UA9	0861-236	
	-stainless steel	UA12/UA6/1834	0861-185	
	-stainless steel	UA9	0861-182	
Door, hinge	-aluminum		0519-087-K	
	-stainless steel		0519-074-K	

OPERATING and MAINTENANCE INSTRUCTIONS
Models: H137PUA...C/H138P1834C and H137PSUA...C/H138PS1834C
Pass-Thru Series Hot Cabinets

