

**LITTLE CAESARS HOT-N-READY
 OPERATING and MAINTENANCE INSTRUCTIONS
 Model: H138NPS-CLC Pass-Thru Hot Cabinet Series**

ELECTRICAL SPECIFICATIONS:

Model No.	Volts	Watts	Amps	Hertz	Phase	NEMA
H138NPS-CLC Series	120	1920	16	60	1	5-20P
H138NPS-CLC 240 Series	240	2000	8.3	60	1	6-15P

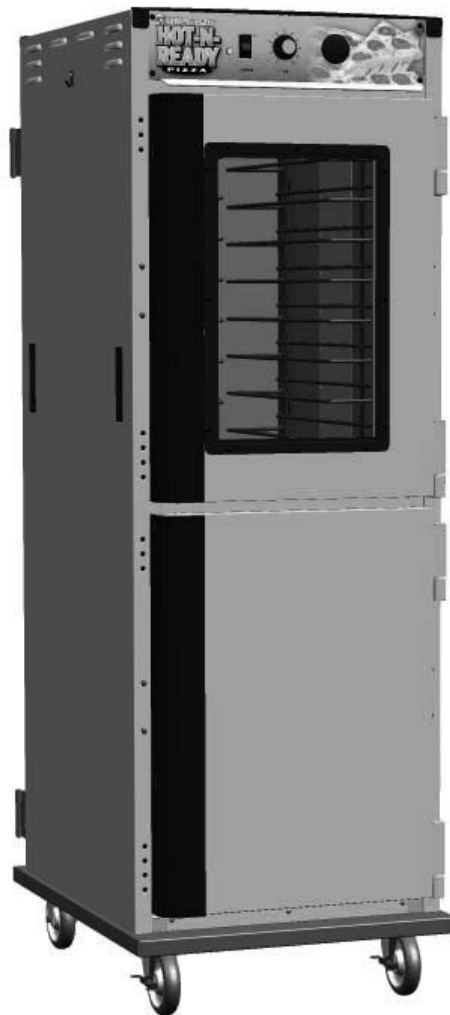

H138NPS-CLC Series

Pass-Thru Holding Cabinet	FL-2254LC
Rev. 7 (7/07)	Page 2 of 4

LITTLE CAESARS HOT-N-READY OPERATING and MAINTENANCE INSTRUCTIONS Model: H138NPS-CLC Pass-Thru Hot Cabinet Series

HOW TO INSTALL UNIT:

1. Place cabinet on level floor.
2. Plug cord into proper wall outlet.

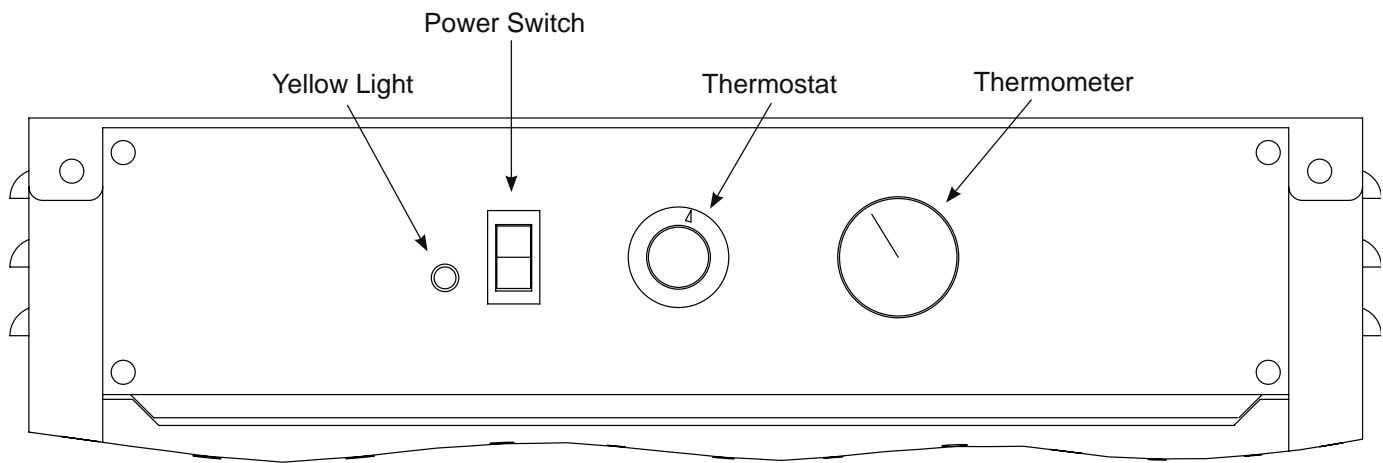

HOW TO START UNIT:

1. Push **POWER** switch to **ON**. The *yellow* light will turn on.
2. Turn thermostat knob to desired setting.
3. Preheat cabinet for 30-45 minutes.
4. Put food into cabinet and close door.

Typical temperature settings:

No. 5-1/2 setting = approx. 160°F/71°C

No. 8 setting = approx. 185°F/85°C

NOTE: Proper food holding temperature is 140°F/60°C or higher.

TO TURN OFF UNIT:

Push the **POWER** switch to **OFF**.
The *yellow* light will go out.

	WARNING	
RISK OF FIRE OR ELECTRIC SHOCK DO NOT OPEN		
<p>WARNING: TO REDUCE THE RISK OF FIRE OR ELECTRIC SHOCK,</p> <p>DO NOT REMOVE COVER (OR BACK)</p> <p>NO USER-SERVICEABLE PARTS INSIDE</p> <p>REPAIR SHOULD BE DONE BY AUTHORIZED SERVICE PERSONNEL ONLY</p>		

LITTLE CAESARS HOT-N-READY OPERATING and MAINTENANCE INSTRUCTIONS Model: H138NPS-CLC Pass-Thru Hot Cabinet Series



BEFORE Cleaning the Cabinet:

1. Allow cabinet to cool.
2. Do NOT use abrasives or harsh chemicals.

Cleaning Notes:

1. Wipe up spills as soon as possible.
2. Clean cabinet regularly to avoid heavy dirt build-up.
3. Make a test spot with cleaner.
4. Follow manufacturer's directions on cleaner.
5. Do not mix cleaners.
6. Avoid drips and splashes.

HOW TO CLEAN UNIT:

SOIL	CLEANER	METHOD
DIRT	Mild detergent* and hot water, or mild abrasive cleaner.	1. Use soft, damp cloth. 2. Rinse with hot water 3. Wipe dry.
	Steam (no strong alkaline additive).	1. Rinse after steam cleaning. 2. Wipe dry.
FINGERPRINTS, GREASE and OIL	Chemical oven cleaner.	Follow oven cleaner manufacturer's directions
	Mild abrasive cleaner; oily or waxy cleaner.	Apply with a soft, clean cloth.
WATER SPOTS	Mild abrasive cleaner.	1. Apply with damp cloth. 2. Rinse and dry.
<i>*Mild detergents include soaps and non-abrasive cleaners.</i>		

TROUBLE-SHOOTING CHART:

FAILURE:

1. Yellow light on switch does NOT light.
2. Unit does not heat.
3. Unit gets too hot or won't shut off.
4. Blower does not work or makes noise.

POSSIBLE CAUSE:

- 1a. Circuit breaker/fuse to wall outlet is blown
- 1b. Cord is unplugged from wall outlet.
- 1c. Switch is "OFF."
- 2a. Thermostat set too low or is "OFF."
- 2b. Switch is "OFF."
- 3a. Defective electrical parts. **UNPLUG UNIT FROM WALL OUTLET:**
- 4a. Defective blower

If cause is none of the above, refer to our list of Authorized Service Centers, FL-1400

Pass-Thru Holding Cabinet	FL-2254LC
Rev. 7 (7/07)	Page 4 of 4

LITTLE CAESARS HOT-N-READY OPERATING and MAINTENANCE INSTRUCTIONS Model: H138NPS-CLC Pass-Thru Hot Cabinet Series

HOT UNIT REPLACEMENT PARTS:

DESCRIPTION	120 VOLT	240 VOLT
Power Unit	0675-048LC	0675-057LC
Heater, Air	0811-074	0811-074-1
High Limit	0848-060	0848-060
Thermometer	5238-030	5238-030
Thermostat, Air	0848-008-ACK	0848-008-ACK
Power Cord	0810-065-12-K	0810-039-07-K
Power Switch	0808-116	0808-116
Power Light	0766-094	0766-095
Vent Fan	0769-165	0769-174
Blower	0769-180-K	0769-182-K

CABINET REPLACEMENT PARTS:

DESCRIPTION	CMP NO.
Door, Full	1221-540
Door, Full, Window	1221-550
Door, Half, Window	1221-535-01
Door, Half	1221-534
Door Gasket, Full	0861-246
Door Gasket, Half	0861-245
Door Hinge (Full Door)	0519-089
Door Hinge (Half Door)	0519-087-K
Door Latch	1006-120-01
Caster	0569-306
Caster with Brake	0569-306-B
Angle Slide Set	0621-281-K
Post, Angle Slide	0696-228
Blower Guard	1170-211

WIRING DIAGRAM Full-Height Pass-Thru Units

NOTES:

- 120V. UNITS - ATTACH WIRE #15 TO TERMINAL #9 OF TEMP. CONT. BOARD.
- 208/240V. UNITS - ATTACH WIRE #15 TO TERMINAL #10 OF TEMP. CONT. BOARD.
- WIRE NUT UNUSED LEAD.
- △ = PROTECTIVE SLEEVE
- BM = BLOWER MOTOR
- FAN = VENT FAN
- A = AMBER (YELLOW) LIGHT

