

OPERATION AND MAINTENANCE MANUAL:

BURGER KING HOLDING UNIT

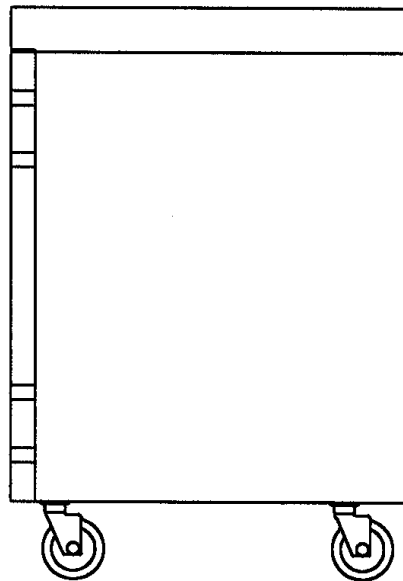
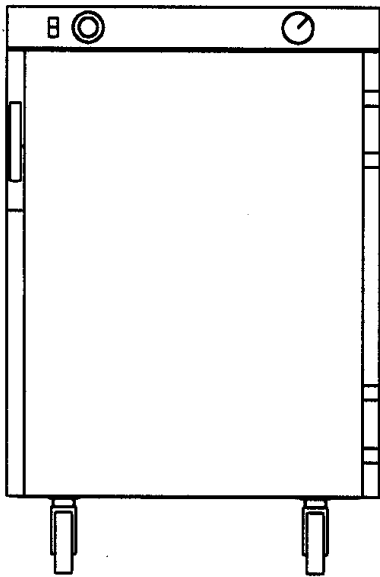

MODEL: H339-135-BKC3

OPERATING and MAINTENANCE INSTRUCTIONS

For HAND-LIFT HOLDING CABINET, H-339-135-BK SERIES

ELECTRICAL SPECIFICATIONS:

MODELS	Volts	Watts	Amps	Hertz	Phase	NEMA
H-339-135-BK Series	120	900	7.5	60	1	5-15
	240	900	3.8	60	1	6-15



All models are: Certified by *Canadian Standards Assoc.* under File No. LR-18148;
Approved by *National Sanitation Foundation* under Standard 4;
Listed by *Underwriters' Laboratories* under filed E27846;
Designed for AC Service.

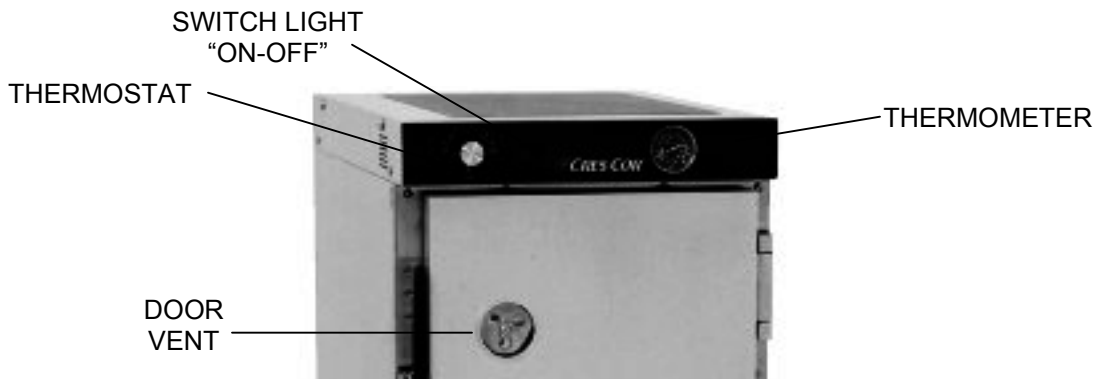

FIGURE 1

HOW TO INSTALL UNIT:

1. Lay cabinet down on its back; look at the bottom plate and note that every corner has a (4) hole pattern that matches up with the holes on the caster plate.
2. Remove the (16) screws that are in those caster mounting holes.
3. Unpack casters and attach them into the (16) holes with the screws provided (add brake casters to front of cabinet).
4. Plug cord into 15-amp wall outlet.
5. Place cabinet in a well ventilated area.
6. Push the switch on, turn the thermostat to No. 10 and run the unit for one hour.

NOTE: DO NOT PUT IN FOOD!

This step is to burn off manufacturing oils and excessive adhesive.

7. Let the cabinet cool and wipe inside clean with detergent and hot water before use.

HOW TO OPERATE UNIT: (Figure 1)

1. Push switch "ON". Yellow light will come on.
2. Turn thermostat to the temperature you need.
NOTE: No. 6½ setting will give you about 180°F/82°C. Proper food holding temperature is 140° F/60°C or higher.
3. Preheat cabinet for 45 minutes
4. Put food into cabinet.
5. Turn the wing nut on the door vent to open the vent when less humidity is needed.

To Turn Off Unit:

Push switch "OFF". The yellow light will go off.

NOTE: Thermometer gives the inside cabinet temperature.

OPERATING and MAINTENANCE INSTRUCTIONS

For HAND-LIFT HOLDING CABINET, H-339-135-BK SERIES



BEFORE CLEANING CABINET:

1. Remove Power Cord from cabinet.
2. Do NOT hose cabinet with water.
3. Do NOT get water on controls.

Do NOT use abrasives or harsh chemicals.

NO OVEN CLEANER!

Cleaning Hints:

1. Wipe up spills as soon as possible.
2. Clean cabinet regularly to avoid heavy dirt build-up.
3. Make a test spot with cleaner.
4. Follow manufacturer's directions on cleaner.
5. Do not mix cleaners
6. Avoid drips and splashes.

HOW TO CLEAN UNIT:

	SOIL	CLEANER	METHOD
CABINET Inside and Outside (Aluminum)	DIRT	Mild detergent* and hot water, or mild abrasive cleaner.	1. Use soft, damp cloth. 2. Rinse with hot water. 3. Wipe dry.
	FINGER PRINTS, GREASE OIL	Steam (no strong alkaline additive)	1. Rinse after steam cleaning. 2. Wipe dry.
		Detergent* and hot water	1. Wipe with soft, damp cloth. 2. Rinse with hot water. 3. Wipe dry.
		Chemical cleaner for aluminum.	Follow cleaner manufacturer's directions.
	Mild abrasive cleaner. Oily or waxy cleaner.	Apply with soft, clean cloth	
WATER SPOTS	Mild abrasive cleaner.	Wipe with damp cloth.	
RACK INSERT Removable (Stainless Steel)	ROUTINE CLEANING	Soap, Ammonia, or mild *detergent and water.	1. Sponge on with cloth. 2. Rinse with water. 3. Wipe dry.
	STUBBORN SPOTS AND STAINS	Mild abrasive made for stainless steel.	1. Apply with damp sponge or cloth. 2. Rub lightly.
	BURNT-ON FOODS OR GREASE	Chemical oven cleaner for stainless steel.	Follow oven cleaner manufacturer's directions.
	HARD WATER SPOTS and SCALE	Vinegar	1. Swab or wipe with cloth. 2. Rinse and dry.

* Mild detergents include soaps and non-abrasive cleaners

OPERATING and MAINTENANCE INSTRUCTIONS

For HAND-LIFT HOLDING CABINET, H-339-135-BK SERIES

HOW TO REVERSE DOOR HARDWARE FOR OPPOSITE HAND (Refer to Fig. 2 [hinge]):

1. Pop off hinge covers with a screwdriver.
2. Remove screws from hinges to door (Item 1) and hinge brackets to cabinet (Item 2).
3. Remove screws from latch to door and latch bracket to cabinet.
NOTE: Keep hinges and latch strike mounted to the brackets.
4. Remove all remaining screws from both sides of door and cabinet in that area. Keep all screws.
5. Turn latch strike bracket 180° and mount it to the opposite side of the cabinet with the same screws you removed. Do the same with the hinge brackets.
6. Line up (4) latch holes to door holes on the opposite side of the door. Mount latch with same screws that were removed.
7. Mount hinges to the opposite side of the door and snap on the hinge covers.
8. Plug remaining holes with screws.

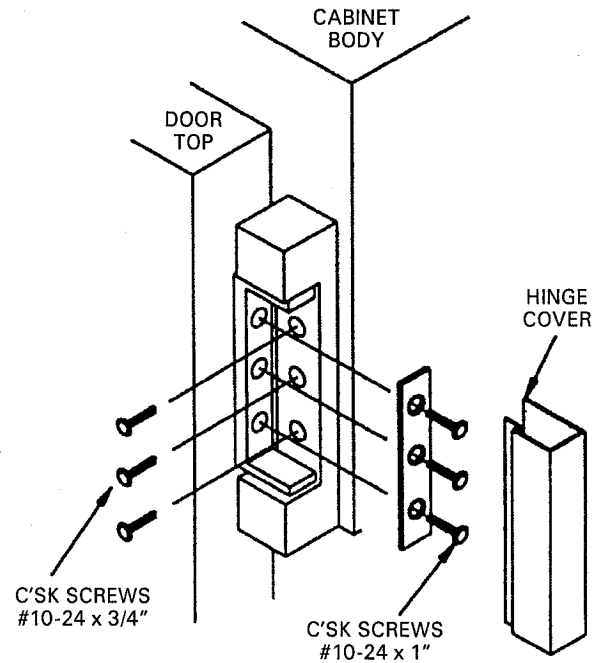

FIGURE 2

TROUBLE-SHOOTING CHART

FAILURE	POSSIBLE CAUSE/CHECK
1. Unit does not heat:	1a. Thermostat turned up.
	1b. Switch is "ON".
	1c. Cord is plugged into outlet.
	1d. Circuit breaker/fuse for wall outlet
2. Unit will not turn off:	2a. Thermostat turned down.
	2b. Switch is "OFF"

If cause is none of the above, refer to our list of authorized service agencies, FL-1400. Instructions for replacing parts are included in replacement parts kits.

REPLACEMENT PARTS

	120V.	240V.
Cord Set	0810-029	0810-139
Switch Kit	0808-113-K	0808-113-01-K
Heater Kit	0811-066-K	0811-066-1K
Thermostat Kit	0848-008-ACK	0848-008-ACK
Terminal Block	0852-091	0852-091
Door Latch Kit		1006-142-K1
Hinge Kit		0519-030-K
Thermometer		5238-030-K
Gasket Kit		0861-077
Rack Insert		1104-083
Door Ass'y., (Reversible)		5508-087
Leg Kit		1206-064
Caster Kit, 3" Dia.		5544
Caster Kit, 5" Dia.		5518

OPERATING and MAINTENANCE INSTRUCTIONS

For HAND-LIFT HOLDING CABINET, H-339-135-BK SERIES

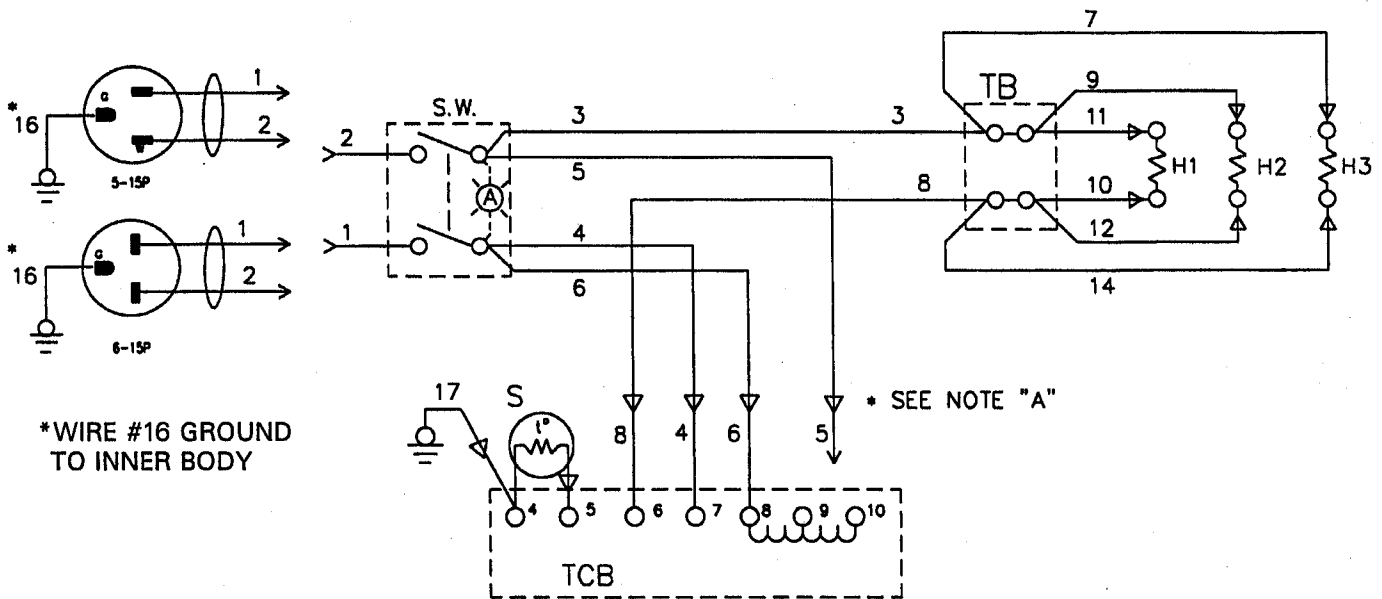

LEGEND

- H1 HEATER - BOTTOM
- H2 & 3 HEATER - RIGHT & LEFT SIDE
- 5-15P PLUG, 120V. 15A.
- 6-15P PLUG, 240V. 15A.
- S SENSOR - AIR
- SW SWITCH - POWER (LIGHTED)
- TB TERMINAL BLOCK
- TCB TEMPERATURE CONTROL BOARD
- △ SLEEVING (12- PLACES)

*NOTE "A"

- FOR 120 V.: ATTACH WIRE #5 TO TERMINAL #9
- FOR 240 V.: ATTACH WIRE #5 TO TERMINAL #10
- ADD WIRE NUT, 0817-004 TO UNUSED LEAD

NON-SKID MAT INSTALLATION FOR COUNTER TOP USAGE

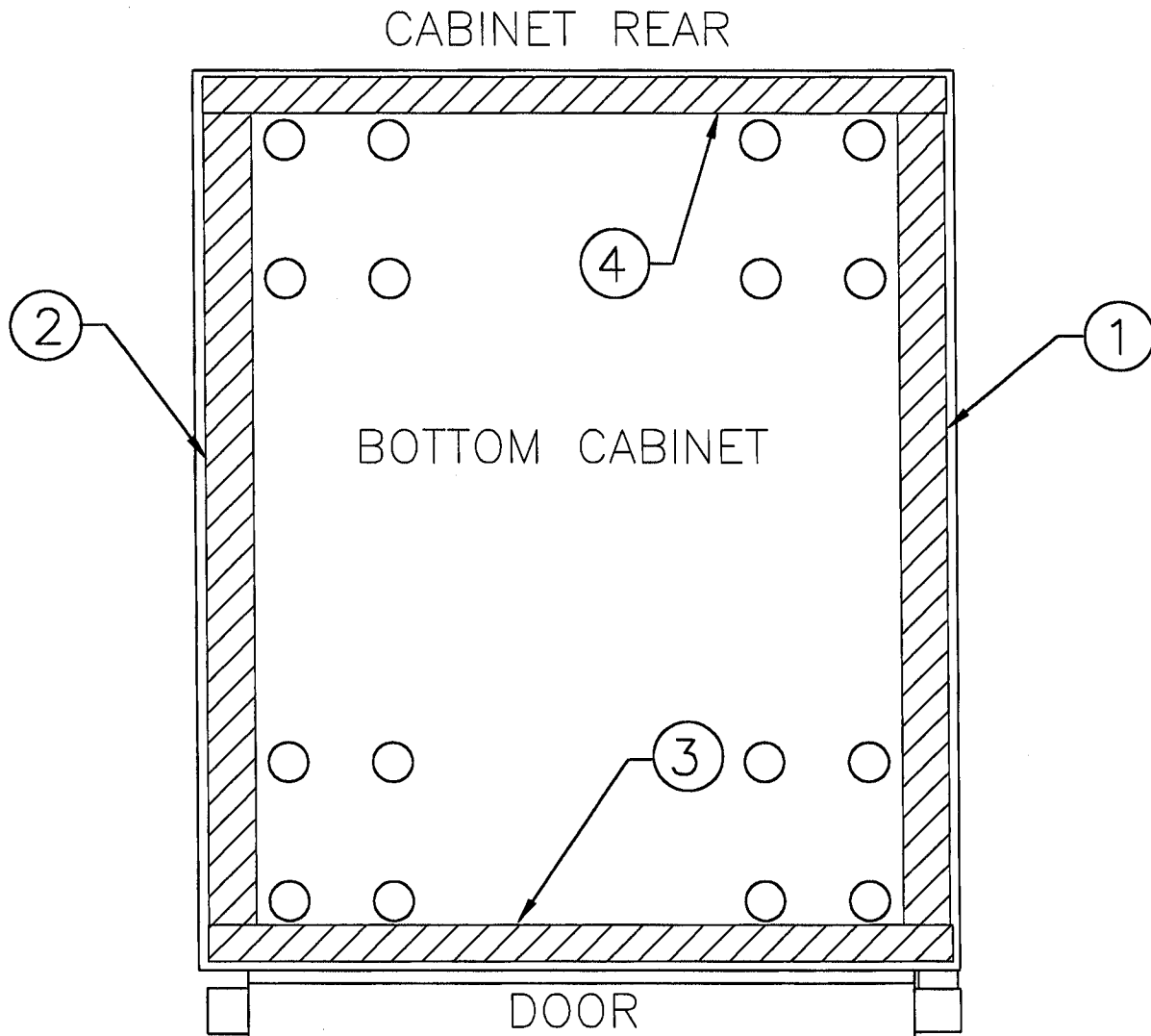

1. LAY CABINET DOWN AND CLEAN THE BOTTOM OF THE CABINET.
2. PULL PAPER BACKING OFF THE ADHESIVE SIDE OF THE (4) PIECES OF SPONGY MATERIAL FOUND INSIDE THE CABINET.
3. INSTALL THE FRONT & REAR PIECES, 17-3/4 " LONG, (ITEMS 3 & 4) ACROSS THE EDGE OF THE BOTTOM PLATE AS SHOWN
4. INSTALL SIDE PIECES, 21-1/4 "LONG (ITEMS 1 & 2) ALONG THE EDGE IN BETWEEN THE FRONT & REAR PIECES.