

OPERATING and MAINTENANCE INSTRUCTIONS For INSULATED UNDERCOUNTER CABINETS MODEL H-339-X-C Series

ELECTRICAL SPECIFICATIONS:

| MODEL | Volts | Watts | Amps | Hertz | Phase | NEMA |
|---|-------|-------|------|-------|-------|------|
| H-339-X-128C, UA-8C, 188C, 12-188C, 1813C | 120 | 900 | 7.5 | 60 | 1 | 5-15 |
| H-339-X-128C-240, 188C-240, 12-188C-240, 1813C-240, UA-8C-240 | 240 | 900 | 3.8 | 60 | 1 | 6-15 |

HOW TO INSTALL UNIT:

1. Plug cord into 15-amp wall outlet.
2. Place cabinet in a well ventilated area.
3. Insert pan slides into the cabinet.
4. Push the switch on, turn the thermostat to No. 10 and run the unit for one hour.

NOTE: DO NOT PUT IN FOOD!

This step is to burn off manufacturing oils and excessive adhesive.

5. Let the cabinet cool and wipe inside clean with detergent and hot water before use.

HOW TO OPERATE UNIT: (Figure 1)

1. Push switch "ON". Yellow light will come on.
2. Turn thermostat to the temperature you need.

NOTE: No. 7½ setting will give you about 180° F. Proper food holding temperature is 140° F or higher.

3. Preheat cabinet for 45 minutes
4. Put food into cabinet.
5. Turn the wing nut on the door vent to open the vent when less humidity is needed.

To Turn Off Unit:

Push switch "OFF". The yellow light will go off.

NOTE: Thermometer gives the inside cabinet temperature.

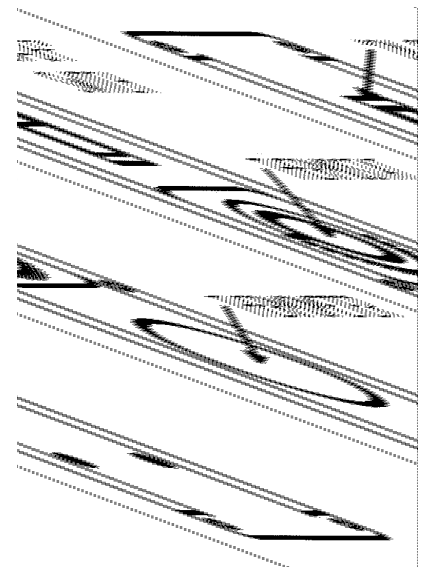
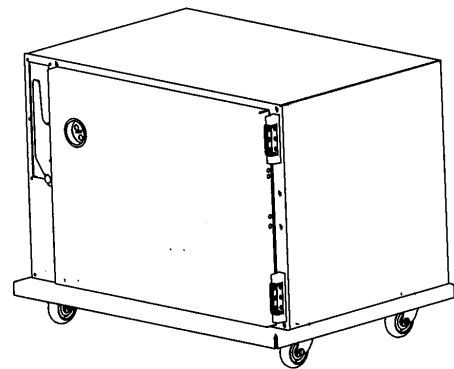

Figure 1
Control Panel

MAINTENANCE INSTRUCTIONS

WARNING

BEFORE CLEANING CABINET:

1. Unplug power cord from wall.
2. Do NOT hose cabinet with water.
3. Do NOT get water on controls.
4. Do NOT use abrasives or harsh chemicals.

Hints:

1. Wipe up spills as soon as possible.
2. Clean cabinet regularly to avoid heavy dirt build-up.
3. Make a test spot with cleaner.
4. Follow manufacturer's directions on cleaner.
5. Do not mix cleaners
6. Avoid drips and splashes.

| | SOIL | CLEANER | METHOD |
|--|-----------------------------|--|--|
| CABINET Inside and Outside (Aluminum) | DIRT | Mild detergent* and hot water, or mild abrasive cleaner. | 1. Use soft, damp cloth. 2. Rinse with hot water. 3. Wipe dry. |
| | FINGERPRINTS, GREASE OIL | Steam (no strong alkaline additive) | 1. Rinse after steam cleaning. 2. Wipe dry. |
| | | Detergent* and hot water | 1. Wipe with soft, damp cloth. 2. Rinse with hot water. 3. Wipe dry. |
| | | Chemical oven cleaner for aluminum | Follow oven cleaner manufacturer's directions. |
| | | Mild abrasive cleaner. Oily or waxy cleaner. | Apply with soft, clean cloth. |
| WATER SPOTS | Mild abrasive cleaner. | Wipe with damp cloth. | |

**Mild detergents include soaps and non-abrasive cleaners.*

HOW TO ADJUST THE DOOR LATCH:

- | | |
|---|--|
| <ol style="list-style-type: none"> 1. For vertical adjustment (Up and down movement): <ol style="list-style-type: none"> a. Loosen (2) screws located in magnetic strike on cabinet. b. Move strike up or down for alignment to magnet on latch. c. Tighten screws to secure | <ol style="list-style-type: none"> 2. For horizontal adjustment (Greater or lesser magnetic draw): <ol style="list-style-type: none"> a. Loosen four (4) screws in latch on door. b. Move latch forward or backward to adjust magnetic draw. c. Tighten screws to secure. |
|---|--|

MAINTENANCE INSTRUCTIONS

HOW TO REVERSE DOOR HARDWARE FOR OPPOSITE HAND

Refer to Fig. 3 (hinge):

1. Pop off hinge covers with screwdriver.
2. Remove screws from hinges to cabinet; remove door and unscrew latch strike from cabinet.
3. Remove hinges, latch and all remaining screws from the right and left side of door. Keep all screws.
4. Re-mount hinges and latch in the same hole pattern on the opposite sides of the door. Plug all extra holes with screws.
5. Remove all screws from the front sides of cabinet (not the top and bottom).
6. Hold door up to cabinet and screw hinges to the cabinet.
7. Open door and re-mount the latch strike to cabinet.
8. Plug all extra holes with screws and snap on the hinge covers.

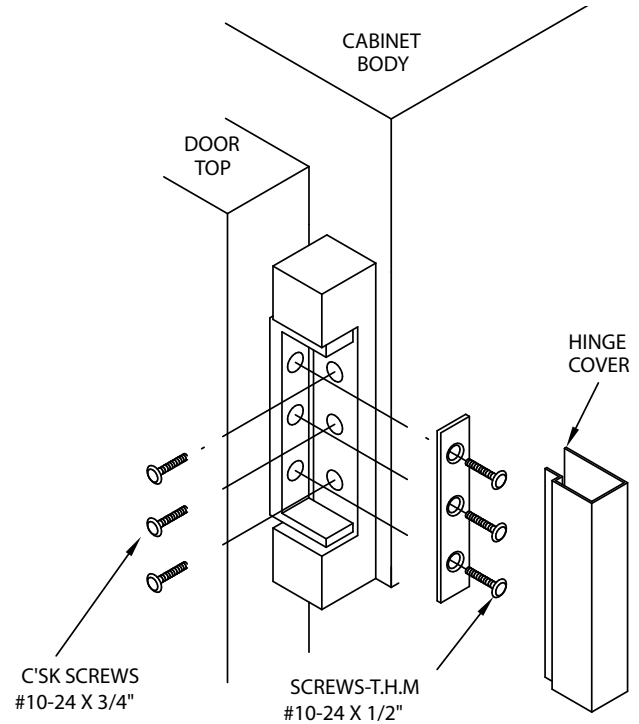

Figure 3

REPLACEMENT PARTS

| | 120V | 240V |
|-------------------------------|--------------------|----------------|
| Switch | 0808-113-K..... | 0808-113-01-K |
| Cord Set | 0810-029..... | 0810-039 |
| Heater Kit..... | 0811-066-K..... | 0811-066-1K |
| Thermostat | 0848-008-ACK..... | 0848-008-ACK |
| Thermostat (before 2011) | 0848-008-ACK-1.. | 0848-008-ACK-1 |
| Thermometer..... | 5238-030-K..... | 5238-030-K |
| Door Latch Kit..... | 1006-122-01-K..... | 1006-122-01-K |
| Strike Kit..... | 1006-122-02-K..... | 1006-122-02-K |
| Hinge Kit..... | 0519-074-K..... | 0519-074-K |
| Gasket Kit | 0861-077..... | 0861-077 |
| Casters..... | 0569-313-K..... | 0569-313-K |
| Casters w/Brake | 0569-313-BK..... | 0569-313-BK |

TROUBLE-SHOOTING CHART

FAILURE

1. Unit does not heat:
2. Unit will not turn off:

POSSIBLE CAUSE/CHECK

- a. Thermostat turned up.
 - b. Switch is "ON".
 - c. Cord is plugged into outlet.
 - d. Circuit breaker/fuse for wall outlet
- a. Thermostat turned down.
 - b. Switch is "OFF"

If cause is none of the above, refer to our list of authorized service agencies, FL-1400.

Instructions for replacing parts are included in replacement parts kits.

| DESCRIPTION | KIT NUMBERS FOR H-339 MODELS | | | | |
|-------------|------------------------------|--------------|--------------|----------------|---------------|
| | -UA-8C | -128C | -188C | 12-188C | -1813C |
| Door Kit | 5508-085-K | 5508-083-K | 5508-084-K | 5508-084-K | 5508-084-K |
| Rack Insert | 0621-281-K | 1170-129 | 1170-130 | 1170-122 | 1137-130-03 |

| | |
|---------------------------|----------------|
| Insulated Holding Cabinet | FL-2300 |
| Rev. 4 (5/14) | Page 4 of 4 |

MAINTENANCE INSTRUCTIONS

* WIRE # 13 GROUND TO INNER BODY

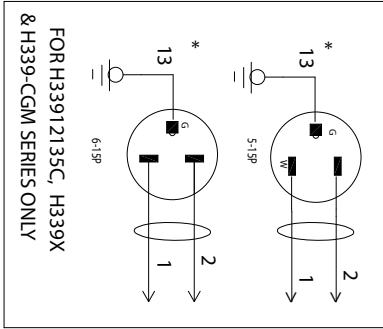
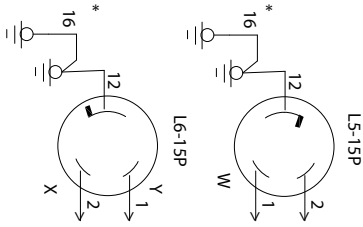

FOR H33912135C, H339X
& H339-CGM SERIES ONLY

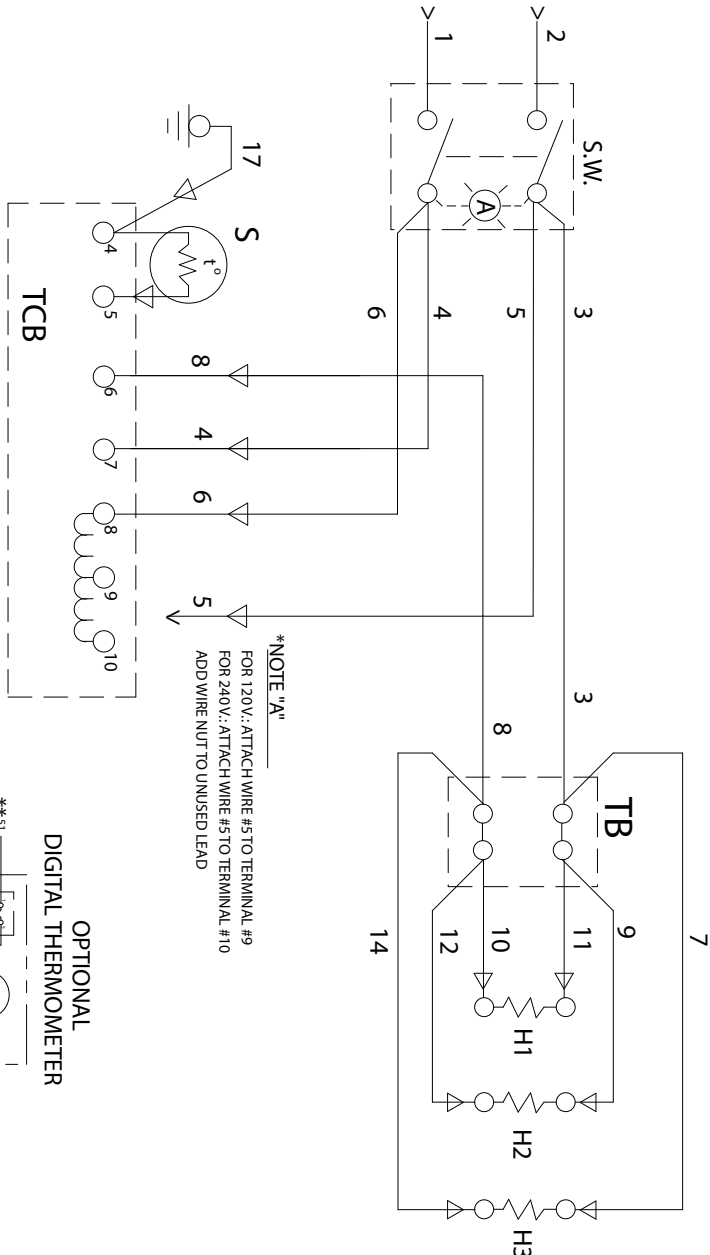

*NOTE "A"
 FOR 120V: ATTACH WIRE #5 TO TERMINAL #9
 FOR 240V: ATTACH WIRE #5 TO TERMINAL #10
 ADD WIRE NUT TO UNUSED LEAD

| ITEM | DESCRIPTION |
|--------|---------------------------------|
| H1 | HEATER BOTTOM |
| H2&3 | HEATER RIGHT & LEFT SIDE |
| L5-15P | FLANGED INLET/120V/15A |
| L6-15P | FLANGED INLET/230V/15A |
| S | SENSOR-AIR |
| S.W. | SWITCH-POWER (LIGHTED) |
| TB | TERMINAL BLOCK |
| TCB | THERMOSTAT BLEEDING (12 PLACES) |

OPTIONAL DIGITAL THERMOMETER

